

An Investigation of Severe Slugging Mitigation Techniques in Deepwater Oil Field Scenerio: A Review Study

Ndubuisi N. Okereke^{*a}, Christian Okalla^a Uzoma J. Ajugwe^b, Charley I. Anyadiiegwu^a, Anthony Kerunwa A.^a, Stephen G. Udeagbara^c

^a Department of Petroleum Engineering, Federal University of Technology, Owerri, Nigerea

^b Department of Civil and Environmental Engineering, University of Florida, US

^c Department of Chemical and Petroleum Engineering, Afe, Babalola University, Nigerea

*Corresponding author e-mail: ndubuisi.okereke@futo.edu.ng

Abstract

Slugging involves a fluctuation of gas phase in pockets and liquid phase surges. As a result, the flow is uneven, and its presence is undesirable. It is common to have severe slugging in the co-current flow of gas-liquid multiphase stream in pipeline-riser systems, which manifests as a substantial fluctuation in flow rate and pressure. It might harm topsides equipment used in processing the multiphase stream. Severe slugging, a type of slugging that typically takes place at the base of the riser column, results in huge amplitudes in the pressure variation within the riser column, which harms equipment that is installed topside. Also, severe slugging can give rise to 50% drop in production; causing a significant problem for the oil and gas industry. In order to better predict it, its properties (slug frequency, length, translational velocity, and liquid holdup), there is an urgent need to better understand the mechanism of severe slugging and ability to model the scenario properly. This study aggregated recent research works on the various severe slugging mitigation techniques and provided a table for comparison of the technical challenges associated with the key severe slugging mitigation techniques especially in deepwater oil field scenarios. The table of comparison could serve as a preliminary design guide at Pre-FEED design stage in deepwater oil field development. This review study also highlighted the conditions leading to severe slugging formation in deepwater oil field scenarios and made recommendations for further studies.

Article Info

Received 10 Oct. 2022

Revised 23 Jul. 2023

Accepted 10 Aug. 2023

Keywords

Slug; Slugging; Severe Slugging; Liquid Hold-up; Self-lift; Riser Base Pressure; OLGA.

Introduction

Slug formation has been proven to have negative effects on production equipment like production valves and manifolds and is attributed to large fluctuations in pressure and flowrate. Slug flow is a common and undesirable multiphase flow regime that occurs in many industrial processes, causing time varying stresses in pipes, supports, and ultimately causes structural fatigue damage and failure (Vidal et al., 2013). This results from the alternating production of crude oil and natural gas bubbles. The petroleum industry places a great deal of emphasis on the ability to predict the liquid holdup and multiphase flow regimes that can exist in a well or pipeline. A multiphase-flow regime in pipes when the heavier fluid is being pushed along by the lighter fluid, which is mostly trapped in big bubbles. The term "slug" usually refers to the heavier, slower flowing fluid, but it can also refer to the lighter fluid bubbles that have consolidated into larger bubbles that now cover a considerable portion of the pipe. Slugging is the term used to describe the buildup of water, oil, or condensate inside a gas pipeline. Slugging is a significant problem for multiphase flow assurance.

The flow regimes frequently observed with the liquid and gaseous phases of hydrocarbons (crude oil and gas) in transit cause slug to form (Al-Kandari and Koleshwar, 1999).

The threat of severe slugging to the production platform and the various methods for eliminating severe slugs were initially identified by Yocum (1973). Since then, numerous attempts to reduce severe slugging have been attempted in an effort to make it possible to extract from deep offshore wells and low-pressure wells. The main approaches, passive slug mitigation and aggressive slug mitigation, can be categorized into two groups. For the application of slug control, active techniques require actuators or external interferences, whilst passive techniques typically incorporate adjustments to the facility's architecture without the need of actuators. The two most common active techniques are smart or dynamic choking and external gas lift. Based on previous literature review, external gas lift can successfully reduce severe slugging, enable continuous production, and ensure a smooth start-up of a pipe system after it has been shut down (Yocum 1973, Schmidt et al. 1979, 1985; Hill 1989,1990).

According to recent studies, maintaining a constant flow of crude oil from the reservoir to the topsides has become a top priority, particularly in offshore production systems (Enilari, B. & Kara, F. 2015). The need to adopt cost-effective strategies to address important flow assurance challenges, such as severe slugging in deepwater scenarios, has arisen as a result of the recent trend of low oil prices. Hydrocarbons can be produced in large quantities from offshore oil resources. Because subsea hydrocarbon processing is difficult, generated fluids are now transported in a multiphase flow stream. The shape of the pipeline riser-pipe system was shown to affect severe slug flow, making it an inevitable occurrence (Schmidt et al., 1985).

Slug Flow

The intermittent movement of liquid slugs followed by longer gas bubbles via a conduit is known as slug flow. In industrial settings, such as oil/gas; production and transportation lines, as well as in boiler and heat exchanger tubes for energy production plants, this flow pattern is frequently seen. The length of the liquid slug and pressure variations can be used to describe the severity of slug flow, which primarily depends on its source. According to (Murashov, 2015), the three primary types of slugging in connection to petroleum multiphase production are as follows:

- **Hydrodynamic slugging:** According to Murashov (2015), hydrodynamic slugs are created when gas-generated waves are swiftly driven across a liquid phase layer. Slugs are created in this scenario when the wave crests reach the top of the pipe, blocking the whole cross section of the conduit. Slugs produced by this method, on average, are not very long.
- **Operationally induced slugging:** This kind of slugging is caused by transient flow regimes in multiphase pipelines, like production ramp-up, ramp-down, and restart operations, and pigging activities.
- **Terrain-induced slugging:** As its name suggests, this type of slug flow occurred at pipeline dips and is typically based on the terrain's contour. When liquid builds up near a dip, there is a propensity for slug formation to clog pipeline cross sections. The slug may extend to significant lengths if a variety of conditions are satisfied before being forced out of the dip by the buildup of upstream gas pressure.

The intermittent slug flow regime may take some distance to develop and it may change with distance as (possibly) the pressure, which affects the gas density, changes. According to classical flow maps, the intermittent slug flow regime exists for a wide range of gas and liquid flow rates in a horizontal or nearly horizontal pipeline configuration.

The names that scientists give each of the flow patterns vary, but the distinctions between them are still minimal. For fixed fluid characteristics and constant horizontal pipe, the primary flow regimes are depicted below.

Slug flow can be produced from stratified flow through two major mechanisms:

- Liquid accumulation due to an immediate pressure-gravitational force imbalance brought on by pipe undulations,
- Natural development of hydrodynamic instability

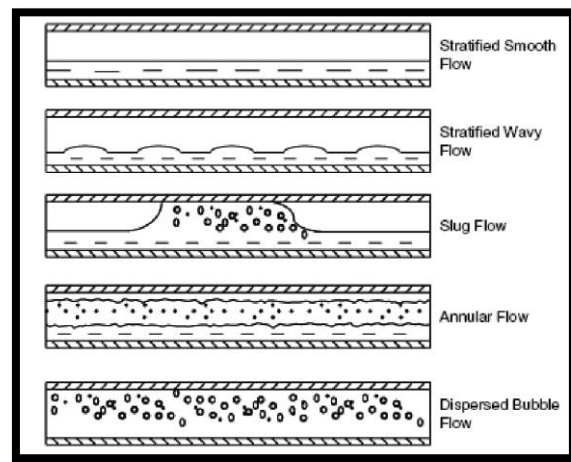

Figure 1 Gas liquid flow regimes in horizontal pipes by Mandhane et al., (1974)

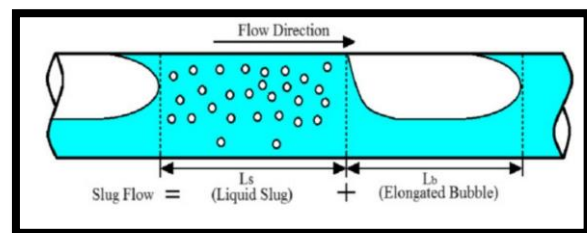

Figure 2 Slug flow in a horizontal pipe (Mendhane et al., 1974)

Gravity acts perpendicular to the flow direction in a horizontal flow regime, causing the following effects, in ascending order of increasing gas flow rate:

- **Dispersed bubble flow:** Although gravity contributes to some separation, for low gas and high liquid flow rates, the liquid flow is high enough to break the gas into dispersed tiny flowing in the continuous liquid phase. Due to their buoyancy, little gas bubbles actually flow through the pipe's upper section.
- **Stratified smooth flow:** When liquid and gas move through a pipe at lower speeds, gravity completely separates the two phases, causing the liquid to flow at the bottom and the gas at the top. Due to the smooth interface between the two phases, this regime is considered to be in a smooth state.
- **Stratified wavy flow:** When gas and/or liquid flow rates are increased from the previously stated flow, liquid and gas are still kept apart, but the interface becomes wavier.
- **Slug flow:** From the stratified wavy flow, the waves become large enough to transcend the pipe diameter and reach the top of the pipe, forming liquid slugs that obstruct gas flow and turn into gas pockets. Small gas bubbles may aerate the liquid slugs.

- **Annular flow:** Because the gas phase is more prevalent in this case, it is the reverse of dispersed bubble flow. As the gas flow continues to grow, the gas forms a core in the middle of the pipe, similar to how the liquid flows as a film along the inside wall. Gravity causes the liquid film in a horizontal flow to be thicker at the bottom of the pipe than at the top. As the gas is being carried by the rapid flow rate, liquid mist or droplets are entrained in the center of the pipe. That is why annular mist flow and annular flow are frequently used interchangeably.

The two-phase flow patterns fluctuate as a result of the flow rates, thus it is appropriate to summarize the findings in a generalized map that includes these parameters.

For illustration, a superficial gas velocity against a superficial liquid velocity can be plotted.

As demonstrated by the map below, Mandhane et al. (1974) investigated the flow pattern maps for an air/water mixture in a horizontal pipe of 0.025m diameter pipe at 25°C and 1bar.

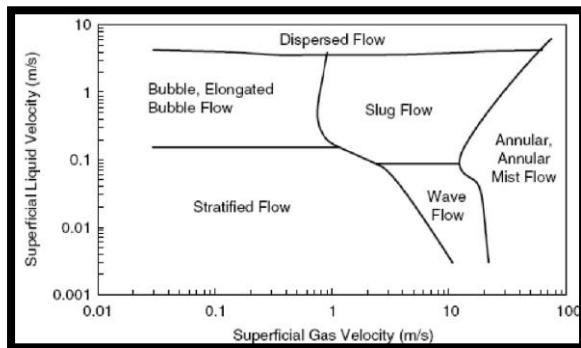

Figure 3 Horizontal flow regime map by Mandhane et al., (1974)

As shown in Figure 3, the Taylor bubbles, which are elongated bullet-shaped gas bubbles that make up the slug flow pattern in a vertical pipe, are separated by liquid slugs that frequently include tiny scattered bubbles.

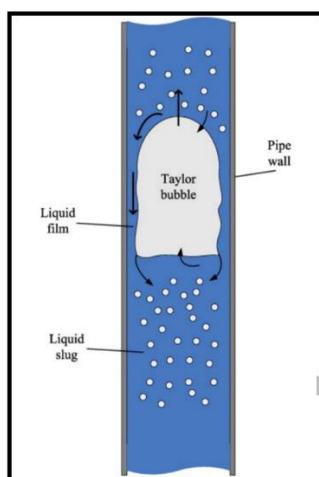

Figure 4 Slug flow in a vertical pipe (Mandhane et al., (1974)

Consequences of Slug Flow

Because slug movement is inherently transient, the intermittent loading it places on processing and transportation equipment could have catastrophic consequences. Due to the damage it does to pipe walls, slug flow can also present safety concerns in

hydrocarbon production lines where the fluids being conveyed may contain corrosive compounds. Furthermore, it is hypothesised that the substantial fluctuations in wall shear stress brought on by this flow pattern may disintegrate coatings that protect pipe walls, making corrosive-erosive attacks simpler to execute. Another feature is the fluctuations in pipe pressure that result from this flow pattern.

Slug flows can be divided into three major categories:

- Hydro dynamic slugging
- Terrain slugging
- Operational induced slugging

This study focused on reviewing severe slugging and the available mitigation techniques for severe slugging.

This terrain-induced slug flow, which occurs when a slightly incline pipeline meets a vertical riser, is best illustrated by severe slugging. An issue with flow assurance is severe slugging.

Slug length

When building the equipment for the downstream process, the liquid slug length is a crucial characteristic to get. The average slug length, according to numerous studies from flow laboratories, is in the range of 10 to 50 D. The maximum slug length is roughly two to three times the average. The length, angle, and diameter of the pipe are thought to be connected to slug dissipation in the upward pipe inclination (Omowunmi et al., 2013). (Ragab and Brandstaetter, 2008). Field scale tests, however, have demonstrated that scale-up significantly affects slug lengths. In actuality, Hill and Wood and Brill et al. (1981) both noted the presence of big slugs (1994).

A wide range of pipe diameters from Prudhoe Bay data with 4, 7, 12, and 16-in diameter pipes, as well as data obtained by Schmidt (1977) and Hubbard (1965) in a 2 and 1.5-in diameter pipe, respectively, were used to construct the correlation by Brill et al. in 1981. They looked at the slug lengths in pipes that were 3 miles long and far from the intake. The pipe diameter and mixture velocity are factors in the slug length correlation that was obtained. The first statistical treatment of the slug length parameter was pioneered by Brill et al. (1981), who made the assumption that the lengths of slugs in fully developed flow are distributed according to a log-normal distribution.

Norris (1982) modified Brill et al. (1981) 's correlation by making the pipe diameter the only factor because he discovered that the mixture velocity did not result in appreciable gains. Additionally, he added one set of data from a 24-in. (61 cm) pipeline diameter at Prudhoe Bay. His slug length correlation only took into account the effect of the pipe diameter while taking into account a wide range of pipe sizes. The Norris correlation performed more accurately when compared to the Brill et al., (1981) correlation.

Liquid Holdup

In a two phase gas-liquid flow, liquid hold up was defined by Murashov (2015) as the volume fraction

occupied by the liquid phase. For instance, a two phase gas liquid flow with a gas volume fraction of 0.25 has a 0.75 liquid hold up. This suggests that the

pipe section is occupied by three-quarters of the liquid volume percentage.

Table 1 Summary of slug length models by Natalie hak (2009)

Authors	Fluids	D [m]	$U_{sl}[m.s^{-1}]$	$U_{sl}[m.s^{-1}]$	Viscosity [cP]	Slug length correlation [m]
Brill et al. (1981)	Air-oil ? (Prudhoe Bay)	0.10, 0.18, 0.12, 0.16, 0.038, 0.0508	-		-	$\ln(l_s) = -3.287 + 4.859 \ln(U_m) + 5.445 [\ln(\frac{D}{0.0254})]^{0.5}$
Norris (1982)	Air-oil (Prudhoe Bay)	0.10, 0.18, 0.12, 0.16, 0.038, 0.0508, 0.61	0.73 – 1.21	2.37 – 9.20	-	$\ln(l_s) = -3.781 + 0.059 \sqrt{\ln(\frac{D}{0.0254})}$
Scott et al. (1989)	Air-water	0.30, 0.41, 0.51, 0.61	0.73 – 1.21	2.37 – 9.20	-	$\ln(l_s) = -25.4144 + 28.4948 (\ln(\frac{D}{0.0254}))^{0.1}$
Nydal et al. (1992)	Air-oil (Prudhoe Bay)	0.053, 0.090	0.6 – 3.5	0.5 – 20	-	15 – 20D for 0.0529m pipe diameter 12 – 16 D for 0.09 m pipe diameter
Hill and Woods (1994)	Air-water Air-oil	0.0779	-	0.46 -	-	$l_s = 3.937U_{sl} * \frac{3600}{f_s} * \frac{1}{H_{Ls}}$
Manolis (1995)	Air-kerosene	0.078	0.5 – 2	0.46 – 8.53	-	10 – 25 D
Marcano et al. (1998)	Air-water	0.0779	0.15 – 2.13	-	-	$l_s = 1.038 + 1.932U_{sl} * \frac{3600}{f_s} * \frac{1}{H_{Ls}}$
Cook and Behnia (2000)	Air-water	0.050	-	-	-	$l_s = 15 D$
Zhang et al. (2003)	Air-water	0.051 to 0.2032	-	-	-	$l_s = 32 D$

Severe Slugging

Current developments have seen an increase in the quantity of long risers supplied by horizontal flow lines due to the ongoing development of offshore oil fields, in West-Africa, Offshore Brazil and Gulf of Mexico. Because of this, the production system is exposed to a severe case of terrain-induced slug flow, or severe slugging. Particularly when reservoir pressure and flow rates are declining, it occurs.

At low mass-flow rates, two-phase flow through a downwardly sloped flow line and a vertical riser results in severe slugging. In cases of severe slugging, liquid builds up in the flow line's riser and curve section, obstructing gas flow at the system's lowest point. As a result, the gas front intermittently penetrates the liquid obstruction, resulting in enormous slugs, harsh variations, and flooding of downstream machinery.

The phenomenon is unstable, leading to significant swings in flow rate and pressure, which could cause issues with platform equipment including separators, pumps, and compressors. In addition, extreme slugging can result in pipe rupture, flooding, over-pressurization in the separator, and increased backpressure at the wellhead. As a result, all of these problems could cause the production facility to shut down entirely.

Severe slugging was divided into two categories by Schmidt et al. (1979): severe slugging with liquid slugs that were typically riser-length and severe slugging with liquid slugs that were slightly aerated but did not extend over the riser pipe's height. Additionally, they claimed that by changing either the liquid or gas flow rate, the first sort of severe slugging could be avoided. But with the second kind of slugging, depending on the liquid flow rate, an increase in the gas flow rate

could result in annular flow or slug flow (Schmidt et al., 1979).

Later, Malekzadeh et al. (2012) divided severe slugging into three types: type 1 refers to a pure liquid slug that is longer than the riser height, type 2 refers to a pure liquid slug that is shorter than the riser height, and type 3 refers to a long aerated liquid slug that grows in the riser and then undergoes a gas blowdown stage.

Stages of Severe slugging

Slug development is the first phase of severe slugging. At this point, the liquid obstructs the gas's flow and raises its level in the riser portion, forming a substantial liquid slug. As a result, the gas phase builds up and is compressed in the flow line. The second stage, slug manufacturing, begins when the liquid slug reaches the riser's top. In this phase, liquid is created as the gas pocket is inflated in preparation for eventual liquid penetration.

The third stage, or blowout, occurs once the gas pressure in the downward-inclined flow line overcomes the hydrostatic pressure of the liquid column. In this stage, the gas pushes the liquid column violently out of the riser. As the pressure declines in the pipeline, the fourth and last stage of the severe slugging phenomenon, liquid fallback, occurs. At this stage, the remaining liquids fall back and accumulate at the riser base and curvature sections.

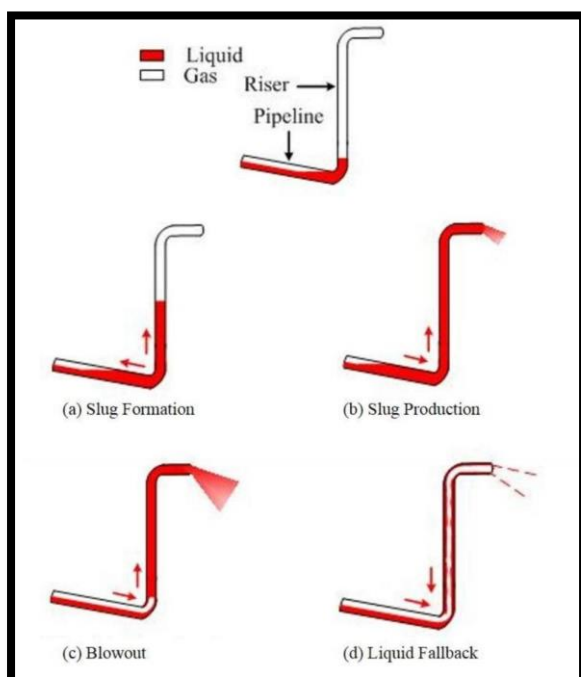

Figure 5 A schematic of the severe slugging phenomenon (Ogazi, 2011)

Severe slug mitigation techniques

Several studies on slug mitigation strategies have been conducted over the years. (Sarica et al., 2000) listed the following as a summary of the main mitigation strategies for severe riser slugging:

- Topsides Choking
- Increase in Backpressure

- Flow line diameter reduction
- Internal small pipe insertion
- Riser base gas injection
- Self-lift slug mitigation technique
- Splitting the flow into dual or multiple streams
- Use of mixing devices at the riser base

This study will also examine a number of well-established methods for reducing slugging in deepwater oil fields.

Topsides Choking

One of the most popular slug mitigation strategies is topsides choking. A choke valve is fitted at the top of the riser using this technique, upstream of the inlets of the separator. Choking the flow causes a shift in the riser's operational pressure, which stabilizes the flow. Even yet, this method has been shown to lessen or even stop severe slugging.

According to Schmidt (1979) and Schmidt et al. (1985), choking at the riser top would reduce or eliminate severe slugging in a pipeline-riser system. The benefit of this approach is that pipeline pressure and flow rates are kept constant.

The work of Schmidt (1979) was continued by Taitel (1986), who also offered a theoretical justification for the effectiveness of choking to steady the flow. Examples from the field demonstrated that choking can be used to stop severe slugging.

According to Sarica et al. (2000), careful choking is required to have the least backpressure increase in order to avoid or minimize production reduction. This is crucial for deep water because potential production losses could make the back pressure increase even more significant.

According to Sarica et al. (2000), careful choking is required to have the least backpressure increase in order to avoid or minimize production reduction. This is crucial for deep water because potential production losses could make the back pressure increase even more significant.

Ogazi (2011) proposed techniques for handling topside chokes at large valve opening but are not yet fully applicable in the industry, although a field trial within north-sea has been performed.

The findings of Omowunmi et al. (2013) demonstrated that topside choking is a more effective method for reducing hydrodynamic-dominated slugs than gas lift alone.

This method might be supplemented with a feedback control, according to Sarica et al. (2014), to manage the biggest choke opening that will stabilize the flow.

Using a choke valve, J.L.A. Vidal et al. (2013) used data from a system containing pressure, temperature, and flow, which are able to quantify minute changes in the pertinent model parameters. For the study of severe slugging in pipeline riser systems, a two-phase flow loop with work fluids of air and water was constructed. The riser is 20 meters high, while the

flow line is 15 meters long and has an inclination of up to 8°. Both have an inner diameter of 76.2mm.

Increase in Backpressure

Yocum (1973) said that while raising backpressure could remove severe slugging, it would be detrimental because it would significantly lower flow capacity. He asserted that major losses in flow capacity would also result from choke.

This approach, according to Sarica et al. (2014), calls for considerable pressure rises at the separator or riser head. Even for shallow water systems, it is not viewed as a feasible solution because the back pressures cause a reduction in production capacity. The decline in production capacity is anticipated to be severe for deep-water production systems.

Flow line diameter reduction

Yocum (1973) outlined many severe slugging mitigation strategies that are still in use today, including reducing line diameter, splitting the flow into two or more streams, injecting gas into the riser, using mixing devices at the riser base, choking, and raising backpressure.

Significantly reducing the diameter of the flowline pipe is not practical, according to Meng and Zhang (2001), since at lower pipe diameters, the needed pressure at the manifold for the maximum design flowrate would be higher than the available pressure.

Internal small pipe insertion

A retrofit option was put up by Wyllie and Brackenridge (1994) to lessen the impacts of extreme slugging. This involved creating an annulus between the pipe and riser by putting a small diameter pipe into the riser. For gas injection, this is utilized. This method might be thought of as a good retrofit solution for an existing riser without any safeguards against excessive slugging. This strategy, however, has the drawback of creating difficulties for activities like pigging. Pipe insertion may not be a feasible solution because pigging is one of the wax management procedures and it is inherently intrusive (Sarica et al., 2000).

Riser base gas-injection

Schmidt (1979) claimed that gas injection reduced severe slugging, but this method was abandoned due to the high expenses of the compressor needed to pressurize the gas for injection and the pipeline needed to convey the gas to the riser base.

Sarica et al. (2000) explored the use of gas injection to mitigate severe slugging and found that with riser injection of around 50% inlet gas flow, the severity of the cycle was significantly reduced. Additionally, a 300% gas injection did not completely eliminate significant slugging.

To stabilize pressure inside the pipeline-riser system and allow the multiphase fluid flow to reach a stable condition, Serica (2000), Pederson (2015), and (Okereke et al., 2022) gas lifts have large gas

requirements and high power requirements for gas to be compressed to the riser base.

This innovative method was employed by Tengedal (2002) to model the mitigation of severe slug at the riser base. The procedure was referred to as "self-gas lifting" because it was believed that no extra gas injection from the platform was necessary (Tengedal, 2002). This strategy seemed to be very advantageous since it might eliminate any additional costs associated with compressing external gas for severe slug mitigation, transporting the gas, and storing it on topside platforms.

. The study concluded as follows:

- The technique resulted in a decrease in both the pressure in the production line and the hydrostatic head within the riser.
- According to experimental findings, for best performance, the injection point should be situated at the same level as or just above the take-off point.
- It was found through testing that when the injection point is higher than the take-off point, a "little choke was needed to steady the flow."
- "Not sensitive to variations with liquid and gas flow rates" was the best way to describe this method of reducing severe slug.

According to Jones et al. (2014), a riser top valve is the best slugging mitigation strategy.

In 2019, Joseph Inok and colleagues proposed a cutting-edge technique for reducing severe slugging. It illustrates how to use a Venturi to boost output, recover, and improve system stability. For severe slug mitigation, a Venturi is connected to the pipeline-riser system upstream of the choke valve before the topside test separator. The 2" pipeline-riser system, which consists of a 40 m long horizontal pipe connected to a 10.23 m high S-shape riser and a 5.2 m horizontal topside section, was used for the experiments. The impacts of Venturi on severe slugging were examined, the effects of Venturi on the stability of the system were examined using the gas perturbation approach, the conventional choking methodology and the Hopf bifurcation technique were merged, and used to investigate the stability and production increase performance of the pipeline-riser with Venturi applied. According to experimental findings, the pipeline-riser system stabilizes more quickly with the Venturi applied and the range of pressure fluctuations is cut by 57%. Additionally, the system was stabilized at a higher valve opening and lower pressure when the pipeline-riser was choked using the Venturi and the choke valve together (bifurcation research) as opposed to just the choke valve alone. Bifurcation (critical valve opening) occurred in the scenario under study ($V_{sl} = 0.25$ m/s and $V_{sg} = 0.37$ m/s) at 18% valve opening and an average riser base pressure value of 2.8 barg for the plain riser. However, when Venturi was used, bifurcation took place at a lower average riser base pressure of 2.5 barg and a higher valve opening of 21%. The venturi's capacity to establish stability at a lower riser base pressure may be explained by the minimal energy loss caused by the progressive change

in shape of the venturi. Venturi therefore caused a 17% increase in valve opening and an 11% decrease in riser base pressure. In actuality, these lead to a rise in oil and gas production.

They also came to the conclusion that the installation of the venturi to the pipeline-riser system reduces severe slugging and stabilizes the system, according to experimental evidence. In comparison to using just the conventional pipeline-riser, it helped the system reach a stable operating position more quickly. Practically speaking, this suggest an increase in system stability and flow assurance. It has been demonstrated that employing the venturi and manual choking together stabilizes the system at a larger valve opening than using manual choking alone.

If the use of controllers to the pipeline-riser-venturi system could enhance the performance of the venturi, more research is required.

Self-lift slug mitigation technique

Injecting some associated gas from the production line into a portion at around one-third from the riser base is the foundation of the self-lift severe slug mitigation strategy (de Almeida Barbuto, 1995). This approach, first put forth by Barbuto, differs from the gas-lift plan for reducing severe slugging, which entails compressing treated gas on the topsides and then sending it through a different conduit to the riser intake. The main idea behind the self-lift approach is to move a portion of the related gas slightly above the riser base from the production line to the riser.

According to Tengesdal (2002), a variable choke operated by a PC-based system would enhance the flow, as depicted in the image below. Tengesdal further suggested studying self-lift with different internal diameters of the self-lift bypass and applying a choke at the bypass in order to increase its industry applicability. Previous self-lift applications concentrated on lab tests, which don't really reflect real-world situations. Therefore, using information from an oil field, this study concentrated on the efficacy of self-lift.

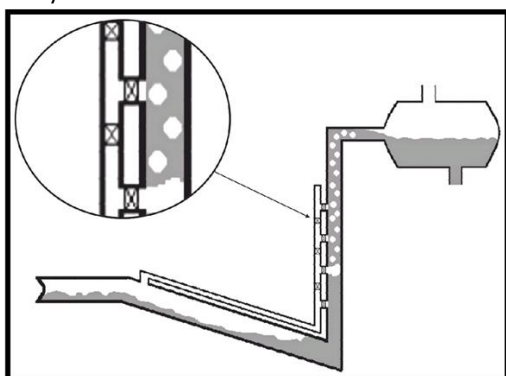

Figure 6 Self lift with small choking at injection points (Tengesdal, 2002)

Advantages of Self-lift Technique

Self-lift displays the following advantages:

- It makes use of the reservoir's gas energy.
- It uses a significant volume of data.
- It can successfully address issues involving sand.

Disadvantages of Self-lift Technique

Self-lift has the following disadvantages:

- Relatively high GOR reservoir is required for Self-lift to be effective.

Self-lift and Gas-lift Severe Slug Mitigation – Deepwater Oil Field Case

Figure 7 depicts how Fikemi Fred et al. (2020) used Pipeline-Riser to model a sample deepwater oil field in West Africa. By adjusting the flow rates, this mild slugging situation was refined to a severe slugging condition. The extreme slugging issue was subsequently mitigated by applying Self-lift and Gas-lift separately. The findings of this study showed that at valve openings of 0.85, 0.65, and 0.35 for a 4 inch and 3 inch diameter bypass line, the self-lift approach is effective. As the mass flow rate increased from 7 kg/s to 12 kg/s, the gas lift approach was found to be effective. Although economic analysis was also done and both strategies lessened the severe slug, the gas lift technique's power usage for 12 kg/s was the best case. However, the best gas-lift case required huge gas volume compression at about 75,921,254.54 kw and at over \$10,000,000 (USD) cost. This was not the case with the self-lift technique which required no external power source for its functionality.

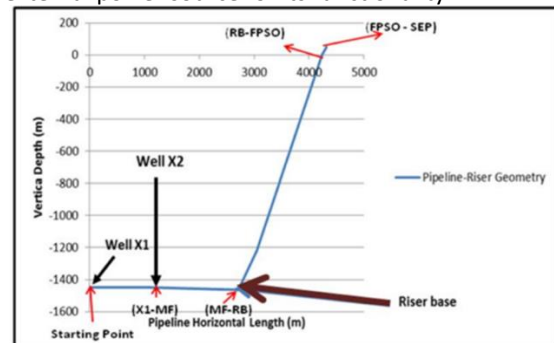

Figure 7 Pipeline-Riser (X1 – X2) Indicating Profile from Seabed to Topsides (Okereke and Omotara, 2018)

The oil field is located within a water depth of about 1463.04m below mean sea level (Okereke, 2018). The field case-study has over 12 subsea production wells producing via 4-slot production manifolds and is tied back to the FPSO via 8 (eight) production risers. This work is focused on Pipeline-Riser (X1 - X2) which consists of two production wells (X1 and X2) combined via a subsea manifold (MF) and tied back to the topsides via an 8" (inches) riser.

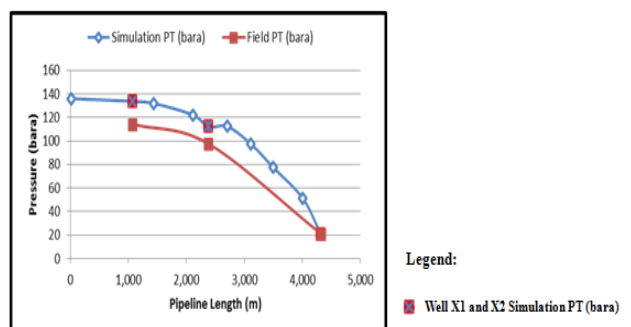

Figure 8 Field Data Vs Simulation Result Comparison (Pressure) (Okereke, et al., 2018)

The table below captures a high level summary of comparison of the key technical challenges involved in some major severe slugging mitigation techniques. From the table, it can be seen that gas-lift technique adapts easily to conventional pigging; however possible deployment of self-lift will require smaller compared. Then generally in terms of production, gas-lift appears to be better from Table 2.

Table 2 Key Technical Challenges of Major Severe Slugging Mitigation Techniques

Technical Challenges	Self-lift Severe Slug Mitigation	Gas-lift Severe Slug Mitigation (RBGL)	Topsides Choking
Managing Pigging Operations	Intelligent pigging solutions	Conventional pigging operations	Not an Issue
Managing Potential Liquid Phase ingress	By-pass pipe dimensioning	Nil	Not an Issue
Managing High Riser-Base Pressure	Feasible at lower Gas Volume	Feasible at Higher Gas Volume	Need for efficient control mechanism
Possible Installation/Retrofitting Challenges	Need for thorough engineering design/installation	Conventional with existing experience	Not an Issue
Production	Moderate Improvement in Production	High improvement in production but associated with high gas compression – Need for optimization studies	Slugging is often stabilized at high percentage choking; leading to low production.

Basis for severe slug mitigation in Deepwater oil fields

In order to access innovative and effective approaches for slug mitigation in deep water scenarios, a deeper understanding of the flow behaviour of critical factors is now necessary due to the introduction of new deep water oil fields.

Okereke et al., (2018) focused on merging the self-lift and gas lift slug mitigation techniques, a novel method for severe slug mitigation in deepwater scenario. In order to break up liquid slug within the riser column and lessen severe slugging, a by-pass pipe along a pipeline upstream of the riser is used to tap off in-situ gas. This gas is then re-injected into the riser column. The study used a methodology that involved comparing field pressure data with OLGA simulation based on input data from the field in order to validate the field data. Self-lift alone was able to reduce hold-up in the riser column in the field scenario, but the pressure trend at the riser column was found to be higher than 290.075 psi, which is the design pressure for the separator inlet. Further study revealed that the pressure at the riser column was stabilised at roughly 290.075 psi by combining both self-lift and gas lift at 2 inches by pass diameter and 8 kg/s gas lift. This study demonstrated that for the combined effectiveness of self-lift and gas-lift slug mitigation strategies, a by-pass internal diameter to pipeline-riser internal diameter ratio of (1:2) or less is required.

Weihong Meng and Jeff J. Zhang carried out a case study on the modelling and mitigation of severe riser slugging in 2001. The study discovered that these

diameter intelligent pigs. Also, in terms of managing potential liquid phase ingress, it is only a challenge with the self-lift approach, as the by-pass pipe sometimes allow a liquid phase to pass through and increase the slugging tendency within the riser-base. Also, in terms of handling high gas volume, In terms of management of high pressure, gas-lift appears to be suited for high GOR among the key methods being

severe slug mitigation strategies reduced the volume and frequency of the slugs to varied degrees of effectiveness. In this case study, increasing the lift gas from the base case of 3 MMSCFD to 1 MMSCFD at the bottom of the wellbore proved to be the most efficient way to stop severe slugging. The riser base gas lift required an additional 3 MMSCFD of lift gas in addition to the lift gas at the bottom of the wellbore. Since it required a 2" reduction in diameter and difficult flowline pigging, reduced riser diameter mitigation proved ineffectual.

Slug catcher slug mitigation approach

A tool known as a slug catcher can also be employed to "smooth" the flow and pressure variations. It is a vessel with the capacity to hold big slugs that is situated between the separator and the pipeline's output. It functions primarily by encouraging stratification between the two phases through a gravity separation. To avoid overloading the equipment after treatment, the fluids might be discharged to it at slower flow rates. The largest volume of slugs that the device must be able to handle must be determined in order to effectively build slug catchers. It's important to note that this also holds true for separators.

OLGA (Oil and GAs) as a slugging modelling tool

A one-dimensional, two-fluid equation based multiphase flow transient tool is called Olga (Oil and GAs). Olga can be used to simulate numerous

transient multiphase flow technical problems as slugging, hydrates, and wax. Olga, a popular multiphase simulator created by IFE and SINTEF in the 1980s, has undergone continual refinement ever since. The 7 fundamental equations that the OLGA transient simulator solves include:

- Separate continuity equation for bulk liquid, gas and liquid droplets in gas.
- Momentum equations with one for liquid and one for combined gas and liquid droplets in gas.
- Combined mixture energy conservation equation.

Depending on the flow regime, all eight equations (0-1 to 0-8) are connected by a closure connection to the wetted parameters or friction factors. (1991, Bendiksen); (Okereke, 2018). Below, the key OLGA equations are highlighted;

Continuity Equations

Gas phase equation:

$$\frac{\delta(V_g \rho_g)}{\delta t} = -\frac{1}{A} \frac{\delta}{\delta z} (AV_g \rho_g v_g) + \psi_g + G_g \quad (1)$$

Bulk liquid phase equation:

$$\frac{\delta(V_l \rho_l)}{\delta t} = -\frac{1}{A} \frac{\delta}{\delta z} (AV_l \rho_l v_l) - \psi_g \frac{V_l}{V_l + V_g} - \psi_e + G_l \quad (2)$$

Liquid droplet within gas phase:

$$\frac{\delta(V_l \rho_l)}{\delta t} = -\frac{1}{A} \frac{\delta}{\delta z} (AV_l \rho_l v_l) - \psi_g \frac{V_D}{V_l + V_D} + \psi_e + G_D \quad (3)$$

Momentum Equations

Gas phase equation:

$$\frac{\delta(V_g \rho_g v_g)}{\delta t} = -V_g \left(\frac{\delta P}{\delta z} \right) - \frac{1}{A} \frac{\delta}{\delta z} (AV_D \rho_l V^2 g) - \lambda_g \frac{1}{2} \rho_l |V_g| V_g \frac{S_g}{4A} + \lambda_l \frac{1}{2} \rho_l |V_r| V_r \frac{S_l}{4A} + V_g \rho_g \cos \theta + \psi_g V_a - F_D \quad (4)$$

Liquid droplets equation:

$$\frac{\delta(V_l \rho_l v_l)}{\delta t} = -V_g \left(\frac{\delta P}{\delta z} \right) - \frac{1}{A} \frac{\delta}{\delta z} (AV_D \rho_l V^2_D) + V_D \rho_l g \cos \theta - \psi_g \frac{V_D}{V_D + V_l} V_a + \psi_e V_i - \psi_e V_D + F_D \quad (5)$$

Liquid at wall equation

$$\frac{\delta(V_g \rho_g v_g)}{\delta t} = -V_l \left(\frac{\delta P}{\delta z} \right) - \frac{1}{A} \frac{\delta}{\delta z} (AV_l \rho_l V^2_l) - \lambda_l \frac{1}{2} \rho_l |V_l| V_l \frac{S_l}{4A} + \lambda_l \frac{1}{2} \rho_l |V_r| V_r \frac{S_l}{4A} + V_l \rho_l g \cos \theta + \psi_g \frac{V_l}{V_l + V_D} V_a - \psi_e V_i + \psi_a V_D - V_l d(\rho_l - \rho_g) g \frac{\delta V_l}{\delta z} \sin \theta \quad (6)$$

$$\frac{\delta(V_g \rho_g v_g)}{\delta t} = -V_l \left(\frac{\delta P}{\delta z} \right) - \frac{1}{A} \frac{\delta}{\delta z} (AV_l \rho_l V^2_l) - \lambda_l \frac{1}{2} \rho_l |V_l| V_l \frac{S_l}{4A} + \lambda_l \frac{1}{2} \rho_l |V_r| V_r \frac{S_l}{4A} + V_l \rho_l g \cos \theta + \psi_g \frac{V_l}{V_l + V_D} V_a - \psi_e V_i + \psi_a V_D - V_l d(\rho_l - \rho_g) g \frac{\delta V_l}{\delta z} \sin \theta \quad (7)$$

Combination of liquid within gas phase and gas phase equation

$$\frac{\delta(V_g \rho_g v_g + V_D \rho_l v_D)}{\delta t} = -(V_l + V_D) \left(\frac{\delta P}{\delta z} \right) - \frac{1}{A} \frac{\delta}{\delta z} (AV_g \rho_g V^2_g + AV_D \rho_l V^2_D) - \lambda_g \frac{1}{2} \rho_l |V_g| V_g \frac{S_g}{4A} - \lambda_l \frac{1}{2} \rho_l |V_r| V_r \frac{S_g}{4A} (V_g \rho_g v_g + V_D \rho_l v_D) g \cos \theta + \psi_g \frac{V_D}{V_l + V_D} V_a - \psi_e V_i - \psi_a V_D \quad (8)$$

The main parameters in equations are: V_g , V_l and V_D volume fractions of gas, liquid and liquid droplets. A is the pipe cross-sectional area, ψ_g is the mass transfer between phases ψ_e and ψ_D are entrainment deposition rates and ρ_l is the density of liquid phase. G is the mass source. θ is the angle of inclination, P is the pressure, ρ_g is the density of gas phase and d is the droplet deposition and S is the wetted perimeter, V_r is the relative velocity and λ is the friction coefficient for gas (g), liquid (l) and finally interface (i).

As regards slug flow regime, OLGA treats the slug as a distributed flow and for fully developed turbulent slug flow with slug lengths large enough; OLGA applied the model proposed by Bendiksen (1984) for the velocity of slug bubbles for all inclinations angles.

In terms of modelling there are also other recognized industry modelling tools such as Ledaflo, which is based on CFD (Computational Fluid Dynamic) type of modelling and has improved prediction of pressure and liquid holdup trends; although they are quite slow in operation.

Conclusions

The paper carried out a thorough comprehensive review on the current state of the art of severe slugging mitigation techniques. Also the key parameters leading to the formation of slugs were reviewed and then a table was developed that highlights key challenges associated with the major severe slugging mitigation techniques deployed in the industry. The following key conclusions were reached in the paper:

- Severe slugging model must be improved by inclusion of a transient model for the calculation of two-phase flow in the pipeline.
- Severe slugging can occur in offshore flowline /riser systems more easily than is normally expected.
- Liquid viscosity has no effect on the occurrence of severe slugging, but an increase in viscosity reduces the slug-arrival velocity
- Pigging can be deployed in the self-lift severe slugging mitigation approach; however it has to be intelligent pigs.
- With the self-lift approach, retrofitting could be a challenge and will require a thorough engineering of the process.
- Management of liquid ingress is mainly a problem that could be associated with the self-lift severe slug mitigation technique.

Recommendations

The study recommends further experimental and numerical studies on the deployment of self-lift severe slugging mitigation techniques; especially in view of the potential 50% saving in gas volume deployed for gas-lifting of the multiphase stream to the topsides.

Also, further trials of the combination of self-lift and gas-lift approach should be considered in future studies on slugging mitigation in deepwater oil field scenario; to improve the options for slugging mitigation in deepwater oil field scenarios.

Conflict of Interest

No Conflict of Interest

References

- [1] Al-Safran, E. (2008). Slug frequency in gas/liquid horizontal flow. In *BHR Group 2008 Multiphase Technology – 6th North American Conference on Multiphase Technology* (pp. 271–240). Banff, AB, Canada: 4–6 June 2008.
- [2] Barreto, C. V., Pimenta, A., Karami, H., Pereyra, E., & Sarica, C. (2017, May). Experimental investigation of severe slugging control by surfactant injection. In *Offshore Technology Conference*.
- [3] Barreto, C. V. (2016). *Effect of foamer delivery location on horizontal wells deliquification* (Master's thesis, The University of Tulsa).
- [4] Bendiksen, K. H. (1984). An experimental investigation of the motion of long bubbles in inclined tubes. *International Journal of Multiphase Flow*, 10, 467–483.
- [5] Bendiksen, K., Maines, D., Moe, R., & Nuland, S. (1991). The dynamic two-fluid model OLGA: Theory and application. *SPE Production & Operations*, 6, 171–180.
- [6] Fikemi Fred, Ndubuisi Okereke, Fuat Kara, Stanley Onwukwe, Adegboyega Ehinmowo, Yahaya Baba, Onyebuchi Nwanwe, & Jude Odo. (2020). Techno-economic comparison of self-lift and gas-lift slug mitigation in deep water.
- [7] Hassanein, T., & Fairhurst, P. (1998). Challenges in the mechanical and hydraulic aspects of riser design for deep water developments. Presented at *IBC UK Conf. Ltd. Offshore Pipeline Technology Conference*, Oslo, Norway.
- [8] Outlaw, J., Guliuzo, R., Lehrer, S., & Barney, B. (2019). Three successful black oil foamer applications in deepwater GoM. *Offshore Technology Conference*.
- [9] Inok, J., Lao, L., Cao, Y., & Whidborne, J. F. (2019). Severe slugging mitigation in an S-shape pipeline-riser system with a venturi for increased production and recovery. *Offshore Technology Conference*.
- [10] Vidal, J. L. A., Monterio, P. C. C., Silva, L. L., & Netto, T. A. (2013). Study of slug control techniques in pipeline systems.
- [11] Lehrer, S., et al. (2011). Development and application of foamers to enhance crude oil production. In *SPE Production and Operations Symposium* (Document ID 141026-MS).
- [12] Malekzadeh, R., & Mudde, R. F. (2012). A modelling study of severe slugging in wellbore. Presented at *North Africa Technical Conference and Exhibition*. Society of Petroleum Engineers.
- [13] Malnes, D. (1982). *Slug flow in vertical, horizontal and inclined pipes* (Report IFE/KR/E-83/002). Inst. for Energy Tech., Kjeller, Norway.
- [14] Mandhane, J. M., Gregory, G. A., & Aziz, K. (1974). A flow pattern map for gas-liquid flow in horizontal pipes. *International Journal of Multiphase Flow*, 1, 537–553.
- [15] Norris, L. (1982). Correlation of Prudhoe Bay liquid slug lengths and holdups including large diameter flow line tests. Internal report, Exxon Production Research Co., Houston, TX.
- [16] Ogazi, I. (2011). *Multiphase severe slug flow control* (Doctoral thesis, Cranfield University). https://dspace.lib.cranfield.ac.uk/bitstream/1826/8345/1/Anayo_Ogazi_Thesis_2011.pdf
- [17] Ogazi, I. A., Cao, Y., Lao, L., & Yeung, H. (2011). Production potential of severe slugging control systems. *IFAC Proceedings Volumes*, 44, 10,869–10,874.
- [18] Okereke, N. U., Ogiriki, S. O., Igbafe, A. I., & others. (2018). Self-lift and gas-lift slug mitigation techniques combined: A new approach to severe slug mitigation in deepwater scenario. In *SPE Nigeria Annual International Conference and Exhibition*.
- [19] Okereke, N. U., & Omotara, O. O. (2018). Combining self-lift and gas-lift: A new approach to slug mitigation in deepwater pipeline-riser systems. *Journal of Petroleum Science and Engineering*.
- [20] Okereke, N. U., Ogazi, I. A., Umofia, A., Ohia, N. P., Udeagbara, S. G., Nwanwe, O., & Kerunwa, A. (2022, August). Investigation of gas-lift mitigation in deepwater pipeline-riser systems. In *SPE Nigeria Annual International Conference and Exhibition*. OnePetro.
- [21] Petalas, N., & Aziz, K. (2000). A mechanistic model for multiphase flow in pipes. *CIM98-39. Journal of Canadian Petroleum Technology*, 39(6), 43–55.
- [22] Pittman, R. (1982). Gas lift design and performance.
- [23] Pots, B. F. M., Bromilow, I. G., & Konijn, M. J. W. F. (1987). Severe slug flow in offshore flowline/riser systems. *SPE Production Engineering*, 2, 319–324.
- [24] Ragab, A., & Brandstaetter, W. (2008). Analysis of multiphase production through hilly terrain pipelines in Matzen Field, Austria by CFD. *SPE Annual Technical Conference and Exhibition*, 1–14. <https://doi.org/10.2118/115355-MS>
- [25] Sancho, A. (2015). *Severe slugging in pipelines: Modelling, simulation and mitigation*. Retrieved from https://fenix.tecnico.ulisboa.pt/downloadFile/1126295043834524/ExtendedAbstract_Andre_Sancho_n70016.pdf
- [26] Sarica, C., Tengedal, J. Ø., & Pennsylvania, T. (2000). SPE 63185: A new technique to eliminate severe slugging in pipeline/riser systems.
- [27] Sarica, C., Yuan, G., Shang, W., Pereyra, E., & Kouba, G. (2014). Feasibility and evaluation of surfactants and gas lift in combination as severe slugging suppression method.
- [28] Schmidt, Z., Doty, D. R., & Dutta-Roy, K. (1985). Severe slugging in offshore pipeline riser-pipe systems. *SPE Journal*, 25, 27–38.
- [29] Scott, S. L., Shoham, O., & Brill, J. P. (1989). Prediction of slug length in horizontal, large-diameter pipes. *SPE Production Engineering*, August, 335–340.
- [29] Shea, R. H., Rasmussen, J., Hedne, P., & Malnes, D. (1997). Holdup predictions for wet-gas pipelines compared. *Oil & Gas Journal*, 95.
- [30] Shea, R., Eidsmoen, H., Nordsveen, M., Rasmussen, J., Xu, Z., & Nossen, J. (2004). Slug frequency prediction

- method comparison. In *BHR Multiphase 2004 Proceedings* (pp. 1–12). Banff, AB, Canada.
- [31] Taitel, Y. (1986). Stability of severe slugging. *International Journal of Multiphase Flow*, 12, 203–217. [https://doi.org/10.1016/0301-9322\(86\)90026-1](https://doi.org/10.1016/0301-9322(86)90026-1)
- [32] Taitel, Y., Vierkandt, S., Shoham, O., & Brill, J. P. (1990). Severe slugging in a riser system: Experiments and modeling. *International Journal of Multiphase Flow*, 16, 57–68. [https://doi.org/10.1016/0301-9322\(90\)90037-J](https://doi.org/10.1016/0301-9322(90)90037-J)
- [33] Tang, Y., & Danielson, T. J. (2006). Pipelines slugging and mitigation: Case study for stability and production optimization. In *Proceedings of the SPE Annual Technical Conference* (pp. 1–10). San Antonio, Texas.
- [34] Tengesdal, J. Ø. (2002). *Investigation of self-lifting concept for severe slugging elimination in deep-water pipeline/riser systems* (Master's thesis, Pennsylvania State University).
- [35] Tengesdal, J. Ø. (2003). Investigation of self-lifting concept for severe slugging elimination in deep-water pipeline/riser systems.
- [36] Tengesdal, J. Ø., Pennsylvania, T., & Thompson, L. (2003). SPE 84227: A design approach for the "self-lifting" method to eliminate severe slugging in offshore production systems.
- [37] Tengesdal, J. Ø., U, P. S., Thompson, L., & Sarica, C. (2005). A design approach for a "self-lifting" method to eliminate severe slugging in offshore production systems.
- [38] Vidal, J. L. A., Cenpes, P., Monteiro, P. C. C., Silva, L. L., & Netto, T. A. (2013). OTC 24293: Study of slug control techniques in pipeline systems.
- [39] Wang, X., Guo, L., & Zhang, X. (2007). An experimental study of the statistical parameters of gas-liquid two-phase slug flow in horizontal pipeline. *International Journal of Heat and Mass Transfer*, 50, 2439–2443.
- [40] Meng, W., & Zhang, J. J. (2001). Modeling and mitigation of severe riser slugging: A case study.
- [41] Wyllie, M. W. J., & Brackenridge, A. (1994). A retrofit solution to reduce slugging effects in multiphase subsea pipelines: The Internal Riser Insert System (IRIS). In *1994 Subsea International Conference*.
- [42] Xing, L., Yeung, H., Shen, J., & Cao, Y. (2013a). Experimental study on severe slugging mitigation by applying wavy pipes. *Chemical Engineering Research & Design*, 91, 18–28. <https://doi.org/10.1016/j.cherd.2012.06.020>
- [43] Yocum, B. T. (1973). Offshore riser slug flow avoidance: Mathematical models for design and optimization. *Society of Petroleum Engineers of AIME*