

## Wireless LED street lighting system design

Bassam A. Abo-El-Ftooh, Hani F. Ragai and Mohamed El-Nozahi

Original  
Article

*Integrated Circuits Lab, Department of Electrical and Electronics Engineering,  
Ain Shams University, Cairo, Egypt.*

### Key words:

Energy conservation, LED street lighting, street light control system, wireless sensor network

**Corresponding Author:** Bassam A. Abo-El-Ftooh, Electronics and Communications Department, Faculty of Engineering, Ain Shams University, Cairo, Egypt.  
**Email:** engineerbassam@gmail.com

### Abstract

This paper presents a wireless sensor network for LED streetlight monitoring and controlling. The proposed system allows substantial energy saving through adequate controlling algorithm. It regulates the streetlight intensity according to the traffic and daylight state. A LED driver is designed to supply the LED with the required 80 W power. The drivers and the controller enable system controlling, monitoring and protection. The system can be widely applied in all places which need controlled lighting such as streets, stations, buildings.

## I. INTRODUCTION

Industry of economic and smart street lighting systems is growing substantially with the rapid growth of cities. LED is considered a promising solution for modern street lighting system due to its behavior and advantages like luminous efficiency, compact size, low maintenance cost, high color rendering index, rapid startup speed, long working life and robustness. A second revolutionary solution is to use remote management systems. This later is basically an intelligent lamppost that sends data to a central management system, simplifying the management, monitoring and control. Many street lamp remote management systems have been developed based on wired networks<sup>[1-5]</sup>. Finally a third solution is based on wireless sensing and actuation to allow for more efficient utilization of street lamp system management. A smart wireless street lighting system, which is electricity conserving, easy to maintain and economic, is proposed in this work. It uses many sensors to control and guarantee the best system parameters. Wireless communication uses ZigBee-based wireless nodes as schematized in Fig. 1. The information is point-to-point transferred using ZigBee transceivers then sent to a control unit that checks the state of the street lamps and takes appropriate measures or decisions.

The purpose of this paper is to design reliable and low cost streetlight node. The node controller makes a light adjustment according to daylight and traffic algorithm. While the node driver dims the lamp up and down according to the controller adjustment. The driver states are fed back to the controller through monitoring and

fault detection signals. The system uses PWM dimming, whose advantages are it will not produce chromatography migration, has higher dimming precision, and compatible with digital control technology. Flicker phenomenon will not happen even if there is a wide range adjustment.

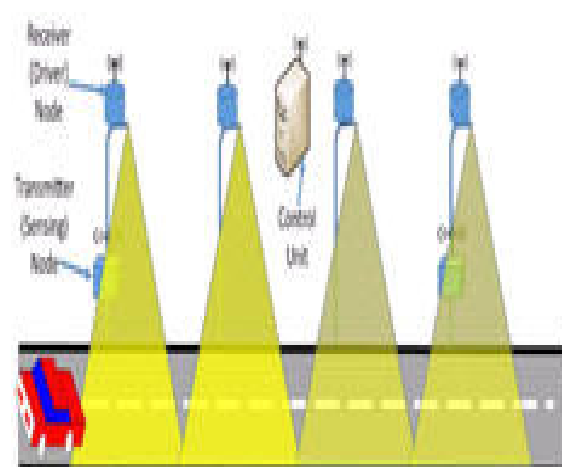

Fig. 1: Propose system architecture.

## II. PROPOSED SYSTEM

### A. SYSTEM ARCHITECTURE

The proposed system blocks for street lights control is shown in Fig 2. The transmitting end consists of power supply, microcontroller (ATmega328), Light sensor (LDR-GL5528), motion detector (PIR-RE200B), and ZigBee module (XBee-XB24-Z7WIT-004). The receiving part consists of power supply, ZigBee module, microcontroller, temperature sensor (DS18B20), and LED driver.

#### A1. Transmitting Node

The LDR with a preset threshold senses the intensity of the daylight, depending on that it activates the lamps on, dim or off as needed. The IR sensor identifies the passage of a vehicle or pedestrian. The light in a particular area shines only when a vehicle enters that area. Depending on the readings of both the LDR and the IR sensors the street lamps is set to a specific lighting level. This feature permits to activate lamps only when necessary, avoiding energy waste. The data is transmitted wirelessly through the ZigBee module to the receiver or to the control unit.

#### A2. Receiving Node

The street-light LED lamps are derived using DC-DC driver. This driver receives a PWM signal from the microcontroller to determine the desired dimming state. The microcontroller fixes this level upon receiving data either from the transmitter or the control unit. Over-temperature protection is carried out using a lamp temperature sensor. Then the light is dimmed or turned off to reduce the consumed current and consequently the lamp temperature.

### B. Prototyping

Figure 2 shows the prototype for the proposed nodes. The node components are: (1) Arduino Pro Mini (compact size allows fitting into a tiny enclosure), (2) Series S2 ZigBee modules for wireless communication, (3) Vero 29 Array LED Module (chip on board light source technology with high efficacy). It has high quality true color reproduction with uniform consistent white light.

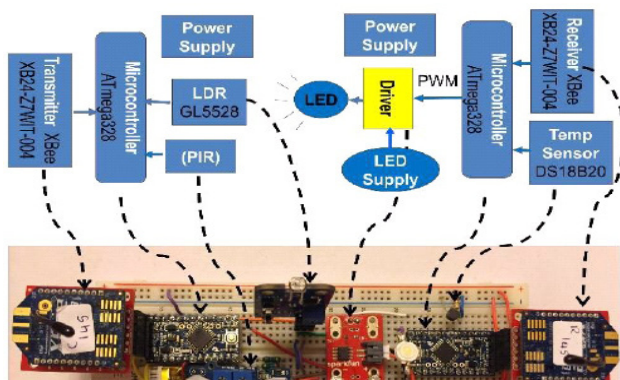

Fig. 2: Initial prototype.

## III. CONTROLLER DESIGN

### A. Transmitting Node Control

The street light control system adopts a dynamic control methodology. The control flow chart is given in Fig. 3. If the LDR measured light intensity is more than 900 lux (day light) the lamp remains Off. If the measured intensity is between 400 and 900 lux, the motion is sensed by the PIR sensor. The lamp remains OFF as long as no motion is detected. If a motion is detected (person or car), the lamp is set to shine with 50% dimming which is enough for the ambient detected light level. If the light intensity is less than 400 lux without any detected motion only 25% dimming is sufficient for safety considerations. The lamp state is set to full lighting level only when the system detects moving objects under low ambient light condition. The state of the lamp is sent to the receiver or the control server only when it changes to save the transmitting power.

### B. Receiving Node Control

At the receiving node, the required state is acquired and the luminaire temperature is measured. An over-temperature protection is implemented as follows; if the temperature is higher than 90°C the lamp will be turned OFF regardless of the required lighting level to protect the luminaire. If not the lamp follows the temperature scheme shown in Fig. 3 to keep luminaire low temperature and safe LED current. A comparison is made between the received and the safe lighting level. The smaller level is the one that will be considered.

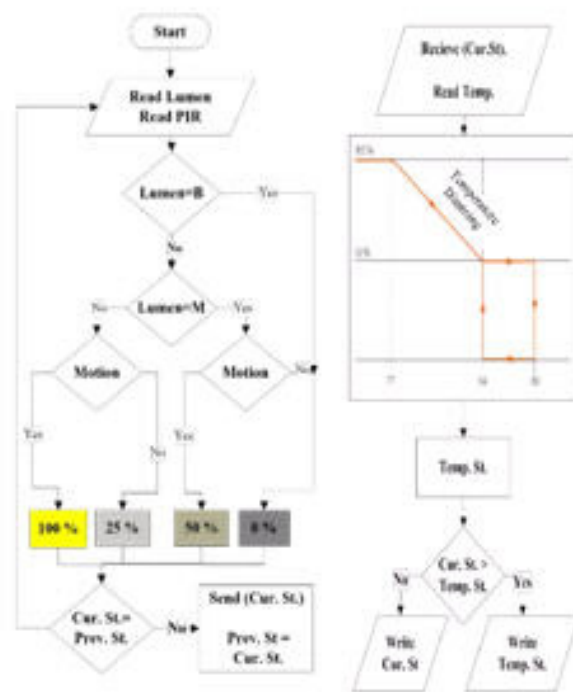

Fig. 3: Transmitter/receiver control flow chart.

#### IV. LED DRIVER DESIGN

The LED driver module is as given in Fig. 4. It consists of full wave bridge rectifier, AC-DC converter, and DC-DC converter. The desired light level is represented as PWM signal from the controller to the DC-DC converter. The converter in turns sends four signals back to the controller. These signals represent different LED circuit conditions including short circuit flag, open circuit flag, thermal shut down command and LED current monitoring signal.

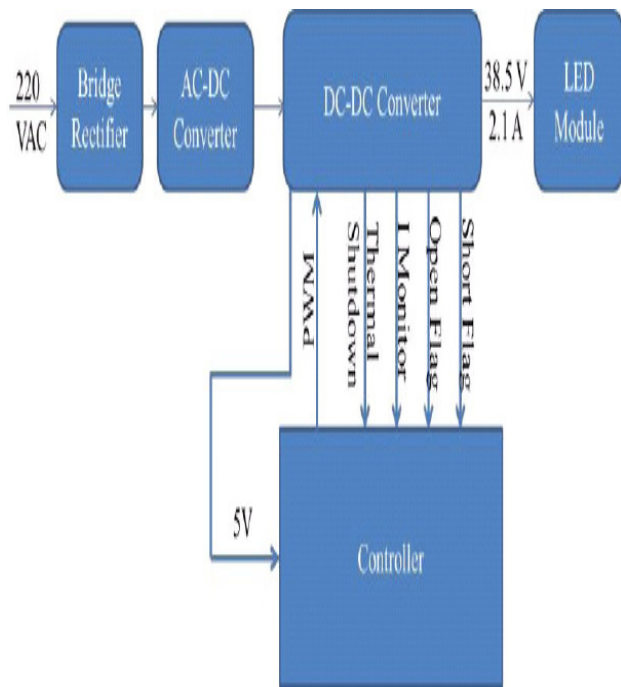

Fig. 4: LED driver block diagram.

##### A. DC/DC Converter

The DC/DC converter is based on LT3795. It regulates a constant-current or constant-voltage for driving the LED. It also drives an external N-channel power MOSFET from an internal regulated 7.7 V supply. The ground referred voltage FB-pin serves as the input for several LED protection features, and also allows the converter to operate as a constant-voltage source. The maximum output current is set by an external resistor, and the output current amplifier has a rail-to-rail common mode range. The LT3795 also includes a separate input current sensing amplifier that is used to limit input current. The TG signal inverts and level shifts the PWM signal to drive the gate of the external PMOS. The PWM input provides LED dimming ratios of up to 3000:1, and the CTRL inputs provide additional analog dimming capability.

##### B. Performance Verification

1) Output Power: According to the Egyptian code of street lighting, an 80 W LED module is required. As shown in Fig. 5 the driver is selected to have 38.5 V DC output with 2.1 A LED current. A 120 mΩ RLED gives the required current. The required output DC voltage is

38.5 V, so R6 and R7 are selected to be 330 kΩ and 10.5 kΩ, respectively. With these values the normal operation signals are obtained as in Fig. 6.

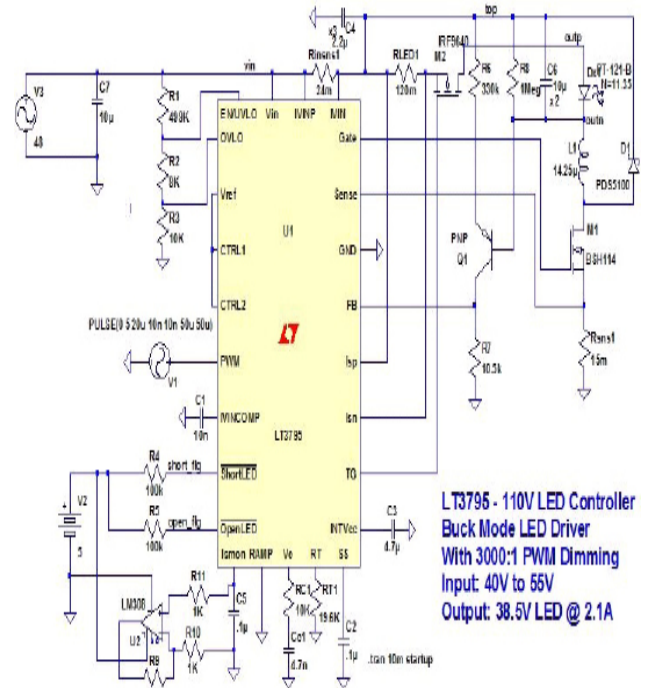

Fig. 5: Driver Schematic Diagram.

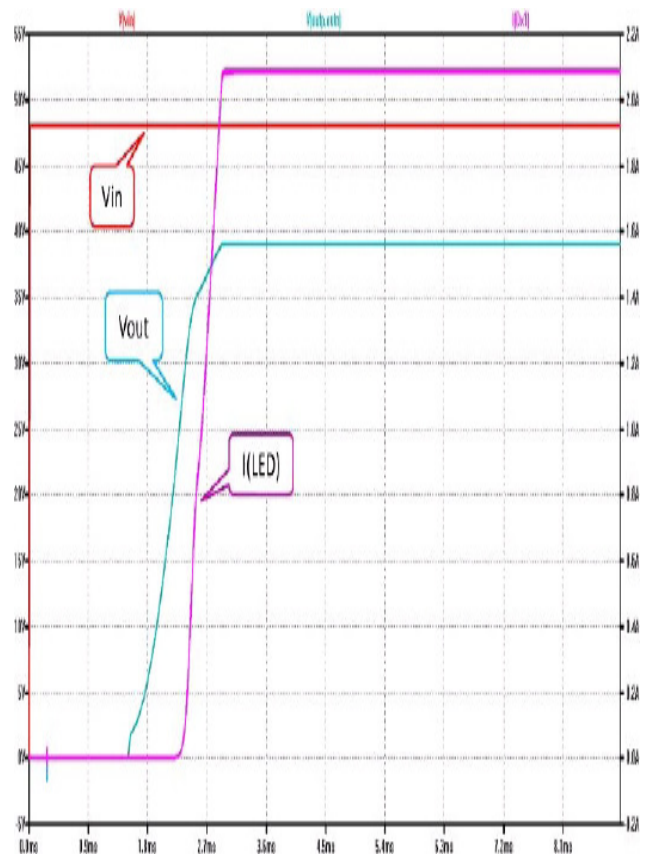

Fig. 6: Normal operation.



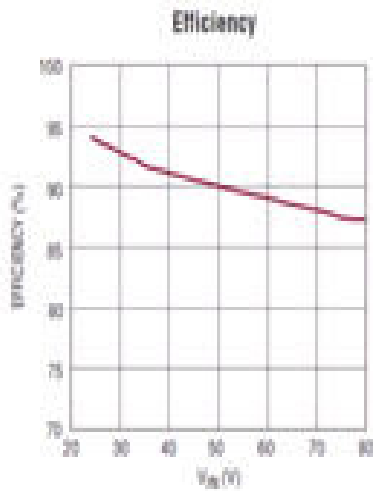

Fig. 7: Driver Efficiency

2) Power Saving: the proposed system introduces substantial power saving thanks to high luminous efficiency LED, intelligent controlling algorithm and the high efficiency LED driver design.

The migration to LED resulted in 50% energy saving; the 160W metal halide lamp can be replaced by 80W LED.

The traffic and day light-based algorithm saves a great amount of energy. According to [6] from midnight to sunrise there is no traffic for 75% of the time which requires minimum lighting level. Also applying the intelligent controlling algorithm for traffic pattern from sunset to midnight would result in 68 to 80 % power saving.

Usage of high efficiency (90%) LED driver will reduce the energy loss. As simulated in Fig. 8 the average input power is found to be 87 W while the output is 80 W.

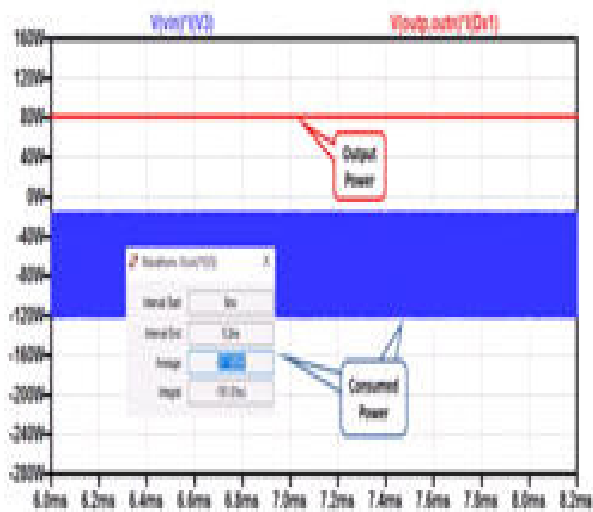

Fig. 8: LED driver power simulation.

3) Fault Signals: Once a fault condition is detected, the PMOS switch is turned OFF to isolate the LED array from the power path, preventing excessive current from damaging the LEDs. A Soft-Start (SS) interval, used as fault timer, is set with an external capacitor. SS signal level must be discharged to less than 0.2 V to reinitiate a soft-start cycle. Switching is disabled until SS signal begins to recharge. If the fault still exists, full SS charge/discharge cycle has to complete (solid line) before switching is ON as shown in Fig.9.

3.1) Short Circuit Flag: One of the fault conditions is the output short circuit. As shown in Fig. 9 if an output short circuit happens (dotted line) a normal-high feed-back flag signal (dashed line) will be forced to low (short circuit detection) and the switching will be turned OFF causing no output current to the LED (dashed-dotted line) (short circuit protection). The short circuit flag will stay low till the fault is repaired and a full SS cycle (solid line) is completed.

3.2) Open Circuit Flag: A second fault is the output open circuit shown in Fig. 10. When open circuit fault occur (dotted line) a normal-switching detection flag signal (dashed line) will be forced low and no output current feeds the LED (solid line) till the fault is repaired.

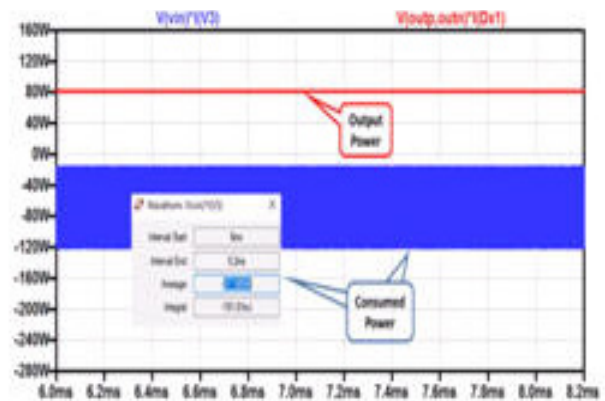

Fig. 9: Short circuit fault.

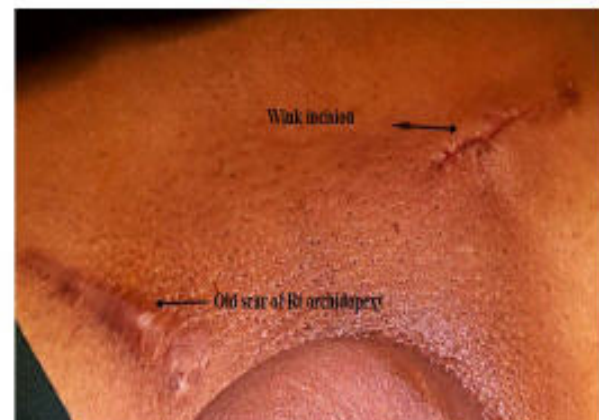

Fig. 10: Open circuit fault.

3.3) Over Temperature and output current monitor: The driver provide over temperature protection. The switching will turned OFF if the temperature exceeds 125°C to protect itself from damage. It also has two CTRL inputs that can be used by external control signals as shown in Fig. 11 (dotted line) for LED analogue dimming by controlling the output current.

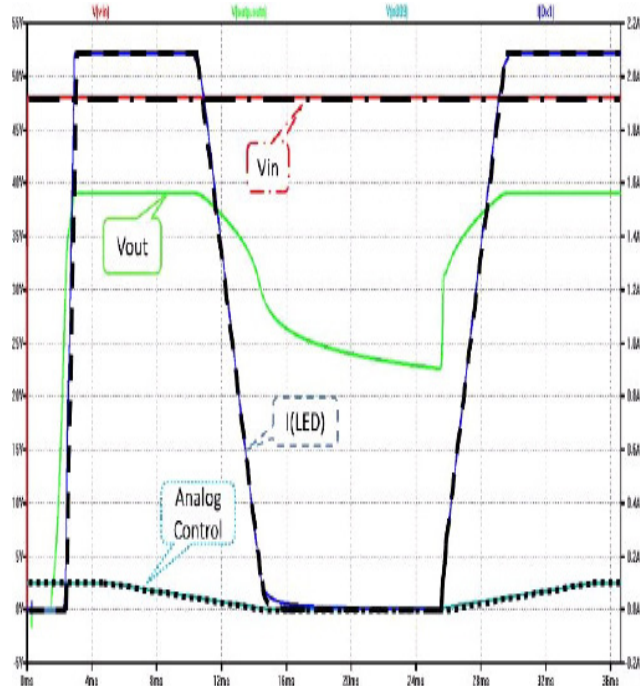

Fig. 11: Over Temperature

## V. IMPLEMENTATION

As shown in Fig. 12 the driver is connected between the LED and the controller. The driver is powered using 48 V DC power supply. It supplies the required 38.5 V and 2.1 A to the LED. The controller is 5 V operated which is supplied by the driver. Different lighting levels are tested due to different daylight and motion conditions. Different fault states are also tested and its feedback are sent to the controller. The controller sent these states wirelessly to a central node. As shown in Fig. 13 a multi-node (sensor and driver nodes) prototype is implemented to be tested in field.

## VI. CONCLUSION

Street-lights are a large consumer of energy for cities, using up to 50 percent of a city's energy budget. The proposed system saves a lot of power. The proposed LED lighting and controlling system uses special power savings mechanism. It adopts a dynamic control methodology according to traffic flow. The implemented drive interfacing the controller to the LED module supplies the appropriate power to the LED and support the system with the required feedback (status) signals. The proposed system is appropriate for street lighting in urban areas and is versatile, extendable and totally adjustable to user's needs.

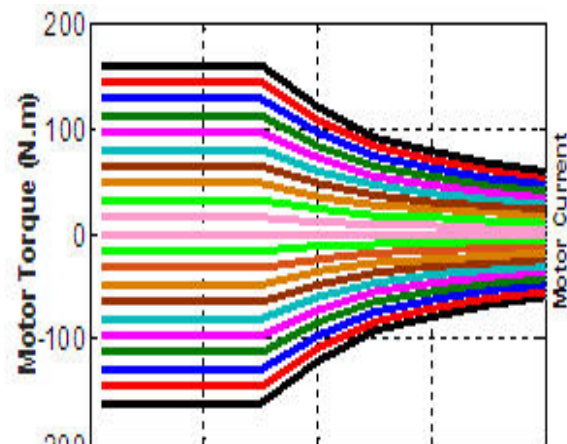

Fig. 12: Final Prototype

$$J_{eq} = 2J_m + J_m \frac{r^2}{R^2}$$

Fig. 13: Four nodes prototype

## VII. ACKNOWLEDGMENT

This work is funded by the European Union through the Egyptian Research, Development, and Innovation (RDI) program, and is undertaken in cooperation with Tegrom – Contract number RDI2/S2/118.

## VIII. REFERENCES

- [1] Vipasha, Preeti Abrol ; "Design of Traffic Flow based Street Light Control System", International Journal of Computer Applications (0975 – 8887), Volume 72– No.18, June 2013.
- [2] Archana M, Mahalahshmi.R , "E – Street: LED Powered Intelligent Street Lighting System with Automatic Brightness Adjustment Based On Climatic Conditions and Vehicle Movements", International Journal of Advanced Research in Electrical, Electronics and Instrumentation Engineering, Vol. 3, Special Issue 2, Apr 2014.
- [3] K.Santha Sheela, S.Padmadevi, "Survey on Street Lighting System Based On Vehicle Movements", International Journal of Innovative Research in Science, Engineering and Technology Vol. 3, Issue 2, Feb. 2014
- [4] Yu Chen; Zhaoyu Liu; , "Distributed Intelligent City Street Lamp Monitoring and Control System Based on Wireless Communication chip nRF401," Networks Security, Wireless Communications and Trusted Computing, 2009. NSWCTC '09. International Conference on , vol.2,no., pp.278-281, 25-26 April 2009.
- [5] Caponetto, R.; Dongola, G.; Fortuna, L.; Riscica, N.; Zufacchi, D.; "Power consumption reduction in a remote controlled street lighting system," Power Electronics, Electrical Drives, Automation and Motion,2008. SPEEDAM 2008. International Symposium on, vol., no., pp.428-433, 11-13 June 2008.
- [6] G. Shahzad, H. Yang, A. W. Ahmad and C. Lee, "Energy-Efficient Intelligent Street Lighting System Using Traffic-Adaptive Control," in IEEE Sensors Journal, vol. 16, no. 13, pp. 5397-5405, July1, 2016.