

THE STATIC AND DYNAMIC PERFORMANCE OF FLUID POWER SERVO CONTROL SYSTEM UNDER VARIATION OF HYDRAULIC ACTUATORS (CYLINDERS) DESIGN

Qassim A. I.¹, Tahany W. Sadak² and Mahassen Rizk¹

¹Department of Production Engineering and Design Faculty of Engineering, Minia University, Minia,

²Department of Mechanical Engineering Faculty of Engineering, Beni-Suef University, Beni-Suef, EGYPT.

ABSTRACT

The fluid power control systems are primarily applied in automated systems such as production systems, flight simulation, robotics, ships and electromagnetic marine engineering, injection molding equipment. In this paper, we investigated the fluid power control system performance by variations of designed hydraulic actuators (cylinders). The system has been designed to offer linear hydraulic displacement with controlled speed for different values of operating variables; supply pressure; p_s , spring stiffness; K , load; W , with constant oil temperature; $T = 30\text{ }^{\circ}\text{C}$ and variability for hydraulic actuators (cylinders) connected to the electrohydraulic servo control valve (SV). The comparison of system flow rate, supply pressure, stroke period and dynamics was investigated. It was found that, when connected to a single-rod hydraulic cylinder, the system exhibits a higher flow rate during the forward stroke compared to the backward stroke. Conversely, a double-rod cylinder achieves a higher flow rate than a single-rod cylinder during backward movement. The actual supply pressure improves in the case of connecting the single rod hydraulic cylinder in forward stroke is higher than on the backward stroke. While the double rod cylinder achieves higher actual supply pressure than the single rod cylinder in backward movement. The frequency of piston displacement decreases with connecting a single rod cylinder in forward stroke ($Cy.2^*$) more than with other cylinders. For example, at $p_s = 50\text{ bar}$ and full stroke the frequencies are 0.093458 and 0.068027 Hz for the double rod cylinder and the single rod cylinder respectively. The bandwidth frequency is higher by 37.34 %.

KEYWORDS

Hydraulic cylinder, Fluid power, servo valve, Hydraulic system, hydraulic actuator.

INTRODUCTION

The fluid power control systems are primarily applied in automated systems, such as production systems, paper machines, an active suspension system, fatigue testing, materials testing equipment, mining equipment, flight simulation, robotics, ships, electromagnetic marine engineering, injection molding equipment, and steel and aluminum mill equipment. The hydraulic actuator (cylinder) is widely used in the hydraulic industry. The hydraulic cylinder is distinguished by its capacity to apply massive forces with excellent precision, making it ideal for applications requiring

precise control and strong force, [1, 2]. Fluid power control systems can use variations of the hydraulic actuator (cylinder) to achieve the required action. In this paper, we concentrate on the design of hydraulic cylinders and compare them to determine the desired design to do the job for optimum performance and to save energy consumption. The design and engineering of hydraulic cylinders are critical for numerous applications, particularly in aerospace and robotics, where minimizing weight and maximizing performance are paramount. Recent advancements focus on exploring innovative materials and structural configurations to enhance both efficiency and operational capabilities, [3 - 7].

In recent years, material development offers appropriate circumstances for the industrialization of hydraulic cylinders and optimizing performance characteristics [8-15]. Many research works have investigated the development of hydraulic cylinder design, such as Wang, Jianwei, et al., [16], the optimization of energy efficiency of hydraulic cylinder systems in the case of driving variable loads using multi-chamber hydraulic cylinder design was investigated. He realized that the multi-chamber hydraulic cylinder achieved energy matching between the single power source and variable loads in the hydraulic cylinder system. Lin, Yonggang, et al., [17], proposed a multi-cylinder electrohydraulic digital loading technique to solve precise load location and enhance the dynamic performance of the electrohydraulic system. Habibi, Saeid, and Andrew Goldenberg, [18], presented the design and prototype of a novel high-performance electrohydraulic actuation system that mixes all the advantages of traditional hydraulic systems with direct-drive electric actuation. Li, Weijian, et al., [19], developed a novel form of digital hydraulic converter with four pump/gear motor units and two types of control valves. They discovered that the suggested digital hydraulic converting can change the hydraulic system's outgoing pressure/flow using the binary digital control, and they confirmed the viability of the pressure change principle of the newly developed digital hydraulic converting. Sochacki, Wojciech, and Marta Bold, [20], described the dampened vibrations of a hydraulic cylinder. The loss of energy from vibration was caused by different kinds of dampening on the vibrations of the hydraulic cylinder. Gamez-Montero, P. J., et al., [21], described the behavior of hydraulic actuators under load and confirmed through experiments. Prabel, Robert, and Harald Aschemann, [22], provides two model-based nonlinear control schemes for a hydraulic system that includes two hydraulic cylinders that are mechanically coupled and each controlled by a different servo valve.

In this work, the static and dynamic characteristics of fluid power control systems with various actuator designs working with a servo control valve are compared. The study examines the many factors influencing the system's ability to achieve position-controlled, linear motion. Energy efficiency, ideal performance criteria, and budgetary constraints may all be used to establish the best system architecture.

SYSTEM DESIGN

The system has been designed to offer linear hydraulic displacement with controlled speed for variable loads such as no-load, 3000, and 5100 N, with constant oil temperature and variability for hydraulic actuators (cylinders). A fluid power control system has been set up and calibrated. The system includes a fluid power supply unit, which delivers the desired flow rate and supply pressure (p_s) to the hydraulic cylinders. The experiment consisted of connecting a servo control valve to the

hydraulic system and evaluating its impact on system performance. The oil tank and unit pipework are designed to meet prescribed requirements. Heating and cooling units work together to ensure a consistent temperature. Figure 1 demonstrates the block diagram of the automatic control system. Figure 2 shows the hydraulic circuit of the fluid power control system.

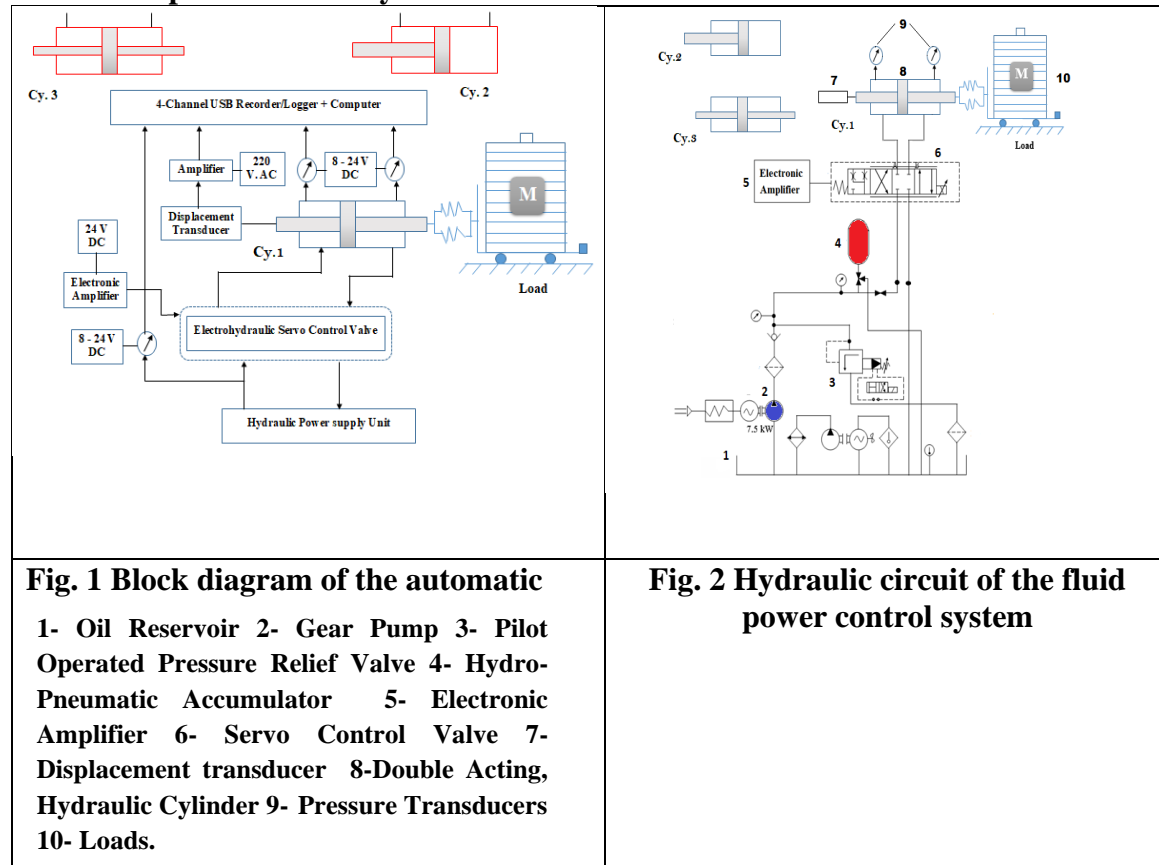

2.1. Flow through Servo Control Valve

The flow rate through the nozzles of the servo control Valve could be calculated considering the well-known law according to Bernoulli equation; [1, 2] as:

$$Q_n = C_d A_n \sqrt{2\Delta p / \rho} \quad (1)$$

2.2. Hydraulic Cylinders Specifications

A low friction, double acting cylinder, double rod and single rod hydraulic cylinders specification are registered in Table 1. These cylinders are shown schematically in Fig. 3.

Table 1 Specifications of hydraulic actuators-(cylinders).

Cylinders	Specifications			
	Rod diameter; [d]	cylinder diameter; [D]	Rod type	Stroke; [mm]
Cy. 1	45 mm	80 mm	double rod	185 mm
Cy. 2	45 mm	80 mm	Single rod	185 mm
Cy. 3	36 mm	80 mm	double rod	185 mm

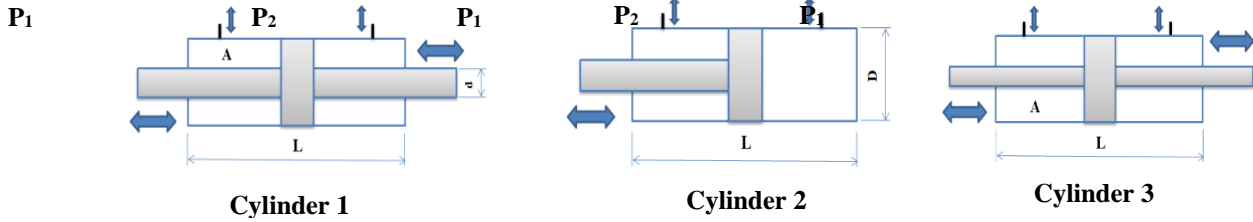

Fig. 3 Schematic drawing of the three hydraulic actuators used in system design.

2.3. Flow through Hydraulic Cylinder

The flow rate (Q) of the fluid flowing in the system neglecting internal and external leakage, compressibility, and any other nonlinearities, could be considered proportional to the velocity of the piston of the hydraulic actuator.

It could be calculated as [1, 2]:

$$Q_c = v \times A \quad (2)$$

The speed of the piston could be calculated from experimental records as the inclination of the displacement - time relationship corresponding to the displacement of the piston of the hydraulic actuator neglecting friction and zero-time period with its nonlinearities according to the equation (3) [1, 2]:

$$v = x / t \quad (3)$$

EXPERIMENTAL

The current experiment investigates the performance of a linear hydraulic control system through an electrohydraulic servo control valve (SV) connection. Variations of the three hydraulic actuators employed in the system building design described in the preceding paragraph. The system has been developed for measuring the variance in system supply pressure and pressure response in the hydraulic actuators' chambers while piston movements.

The displacement and velocity of the piston of the hydraulic actuator, accordingly the flow rate, has been experimented under different values of operating variables; supply pressure; $p_s = 10, 20, 30, 40$ and 50 bar, system stiffness; $K = 0.0, 18$ and 32 N/mm, temperature; $T = 30$ °C, load; $W =$ no-load, 3000 and 5100 N.



Fig. 4 Front photograph of the linear hydraulic system linear under experiments; system under loading



Fig. 5 Photograph of the rear view of hydraulic control system.

Pressure relief valve

Pressure filter

In this experiment, an electrohydraulic servo control valve (SV) was connected to the hydraulic system and the experiment was run. Evaluate the system's performance with various hydraulic actuators. Figures 4 and 5 illustrate photographs of the system

under research. The performance of spool valve, the effect of flow force, load and decay of supply pressure during system operation are discussed. Investigations the effect of hydraulic actuators design and stroke period on system static and dynamic performance. Results of the experimental work are compared.

4.1. Evaluation of System Flow Rate

4.1.1. Effect of hydraulic actuators design on system flow rate

Evaluation of system flow rate for variation of connected actuators as cylinder 1, cylinder 2 and cylinder 3 at supply pressure; $p_s = 10, 20, 30, 40$ and 50 bar is discussed. Comparison of that designs when connecting to SV, temperature; $T = 30$ °C, full opening valve; Φ , stiffness; $K = 32$ N/mm and under load; $W = 5100$ N is recorded at Table 2 and illustrated in Fig. 6. The curves of all cases are calculated according to equations 1 & 2.

Table 2 Variation of system flow rate; Q in relation to supply pressure for the three cylinders design at stiffness; $K = 32$ N/mm, under load; $W = 5100$ N and $T = 30$ °C.

p_s ; [bar]	10	20	30	40	50
Cylinder Type	Q; [mL/s]				
Cy.1	11.37	23.02	34.36	44.77	53.88
Cy.2*	13.72	25.69	39.56	51.12	63.28
Cy.2**	9.96	18.69	27.63	36.53	47.8
Cy.3	11.26	24.33	36.36	47.86	58.85

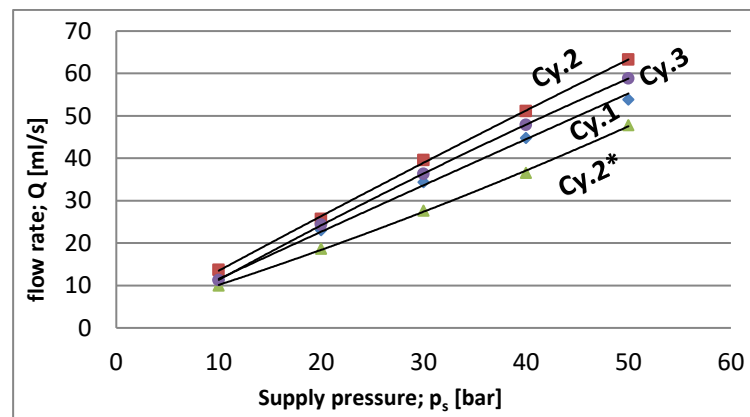

Fig. 6 Variation of system flow rate; Q in relation to supply pressure for the three cylinders design at springs; $K = 32$ N/mm, under load; $W = 5100$ N and $T = 30$ °C.

The flow rate output through the Cy.2* at full stroke is 63.28 mL/s, the flow rate output through Cy.3 is 58.85 mL/s and the flow rate output through Cy.1 is 53.858 mL/s. while the flow rate output through Cy.2** is 47.80 mL/s. The values are presented in Table 3. So, the design of connecting the cylinder 3 achieves highest improvement in flow rate value by 23.12 % than the designs of connecting the other cylinders.

Table 3 Comparison of system flow rate; Q for the two system designs (Different cylinders) for supply pressure; $p_s = 50$ bar under no-load.

System Designs	Cy.2**	Cy.1	Cy.3
Flow Rate Q; [mL/s]	47.80	53.88	58.85
Improvement of the Cylinders; [%]	Ref.	12.72%	23.12%

The values are presented in Table 4. So, the design of connecting the cylinder 2 in forward displacement (Cy.2*) achieves highest improvement in flow rate value by 32.39 % than the flow rate in backward direction of same cylinder.

Table 4 Comparison of system flow rate; Q in case of connecting the single rod cylinder in forward and backward movement for supply pressure; $p_s = 50$ bar under no-load.

System Designs	Cy.2**	Cy.2*
Flow Rate Q; [ml/s]	47.80	63.28
Improvement of the Cylinder 2; [%]	Ref.	32.39%

4.1.2. Load effect on hydraulic actuator design system Flow Rate.

The effect of load variation on the hydraulic system flow rate is evaluated. Load value varies as: W = no-load and 5100 N at supply pressure; $p_s = 50$ bar is discussed. Comparison of that actuator designs when connecting to SV, temperature; $T = 30$ °C, full opening valve; Φ and stiffness; $K = 32$ N/mm is recorded at Table 2 and illustrated in Fig. 6.

Table 5 comparison of system flow rate; Q for the three cylinder design under variation of load; W at supply pressure; $p_s = 50$ bar, stiffness; $K = 32$ N/mm and Temperature; $T = 30$ °C.

Cylinder type	Load condition	Flow rate; Q [ml/s]
Cy.1	No-load	58.31
	5100 N	53.88
Cy.2*	No-load	65.50
	5100 N	63.28
Cy.2**	No-load	48.90
	5100 N	47.80
Cy.3	No-load	59.81
	5100 N	58.85

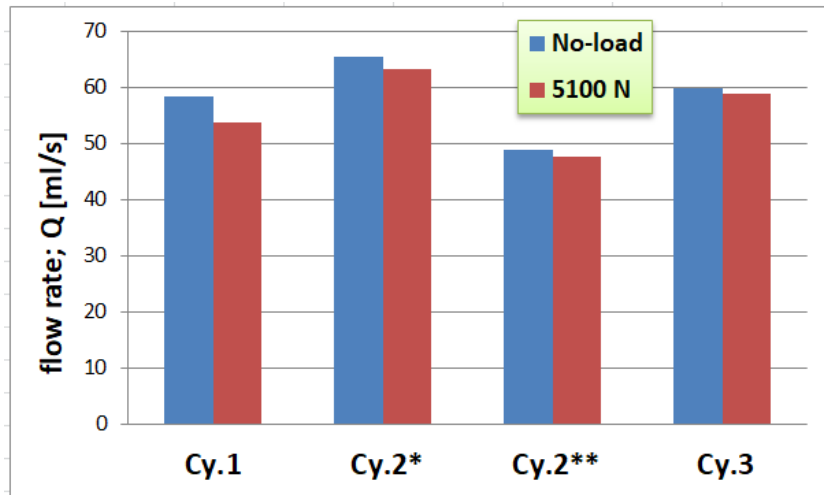

Fig. 7 comparison of system flow rate; Q for the three cylinder design under variation of load; W at supply pressure; $p_s = 50$ bar, stiffness; $K = 32$ N/mm and Temperature; $T = 30$ °C.

Comparing the results in Fig. 7 with Table 6, it is clear that as the load increases, the flow rate decreases, and as a result, the load's speed reduces for a certain system supply pressure.

4.2. Evaluation of System Supply Pressure Decay

4.2.1. Effect of cylinder type on actual supply pressure decay

In this investigation will evaluate the effect of system variation hydraulic cylinder design on system performance of actual supply pressure decay. Three hydraulic actuators design connected to system under load; $W = 5100$ N and springs; $K = 32$ N/mm at full valve opening have been extracted from experimental records values of percentage of actual supply pressure to initial value of supply pressure p_{sa}/p_s are calculated for the all cases and presented in Table 6 then plotted in Fig. 8 for all system cases.

Table 6 Pressure ratio; p_{sa} / p_s for different cylinders design at maximum flow rate and under load; $W = 5100$ N with springs; $K = 32$ N/mm.

p_s ; [bar]	p_{sa}/p_s ; [%]			
	Cy.1	Cy.2*	Cy.2**	Cy.3
10	63.476400	68.617600	48.4934	64.9668
20	48.742155	59.444300	38.836665	48.464415
30	46.412600	53.076100	36.506133	48.166267
40	41.431325	50.649850	34.668775	42.4251
50	40.271680	52.305640	34.03406	41.878060

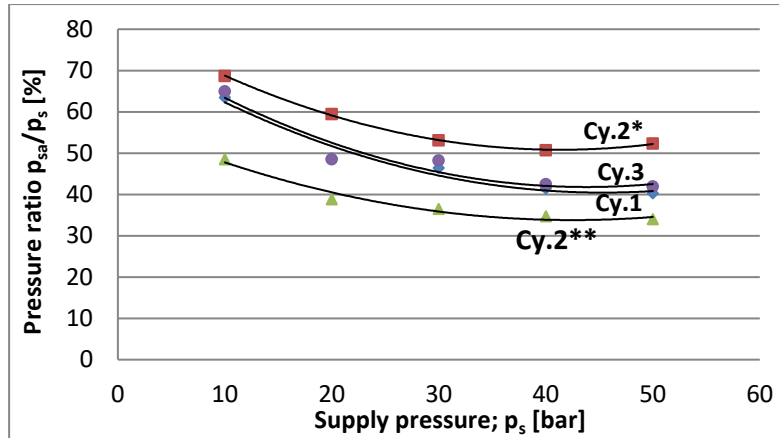

Fig. 8 Pressure ratio; p_{sa}/p_s for Cy.1, Cy.2*, Cy.2** and Cy.3 at $T = 30\text{ }^{\circ}\text{C}$, maximum flow rate and load; $W = 5100\text{ N}$ with springs; $K = 32\text{ N/mm}$.

The comparison of the results of this investigation in case of connecting three hydraulic actuators design, declared that the value of actual supply pressure in the case of cy.2** is 17.01703 bar, in case of cy.2* is 26.15282 bar, in case of cy.1 is 20.13584 bar and in case of cy.3 is 20.93903 bar at $30\text{ }^{\circ}\text{C}$ and $p_s = 50\text{ bar}$. The values are presented in Table 7. So, the design of connecting the Cy.2* achieves highest an improvement in actual supply pressure by 53.69 % than the designs of connecting the other cylinders.

Table 7 Comparison of system Actual supply pressure; p_{sa} for all the cylinders for supply pressure; $p_s = 50\text{ bar}$, $T = 30\text{ }^{\circ}\text{C}$, $K = 32\text{ N/mm}$ and load; $W = 5100\text{ N}$.

Cylinder type	Cy.2**	Cy.2*	Cy.1	Cy.3
Actual Supply pressure; p_{sa} [bar]	17.01703	26.15282	20.13584	20.93903
Improvement; [%]	Ref.	53.69 %	18.33 %	23.05 %

4.3. Effect of System Design on Stroke Period

4.3.1. Effect of hydraulic actuator type on system stroke period

The values of stroke period during system operation under load; $W = 5100\text{ N}$, stiffness; $K = 32\text{ N/mm}$, supply pressure; $p_s = 10, 20, 30, 40$ and 50 bar and temperature; $T = 30\text{ }^{\circ}\text{C}$ have been extracted from experimental records. Comparison of system stroke period of the three types of hydraulic actuators to evaluate the effect of actuators design on system dynamics performance, values shown in Table 8 and Fig. 9.

Table 8 Comparison of stroke period for cylinder types at supply pressure; $p_s = 50\text{ bar}$, $T = 30\text{ }^{\circ}\text{C}$, $K = 32\text{ N/mm}$, $W = 5100\text{ N}$.

hydraulic actuator Types	Cy.2*	Cy.2**	Cy.3	Cy.1
Stroke period; t [sec]	14.7	13.5	12.2	10.7
Improvement of Decreasing the required time at same displacement length; [%]	Ref.	8.88%	20.49%	37.38%

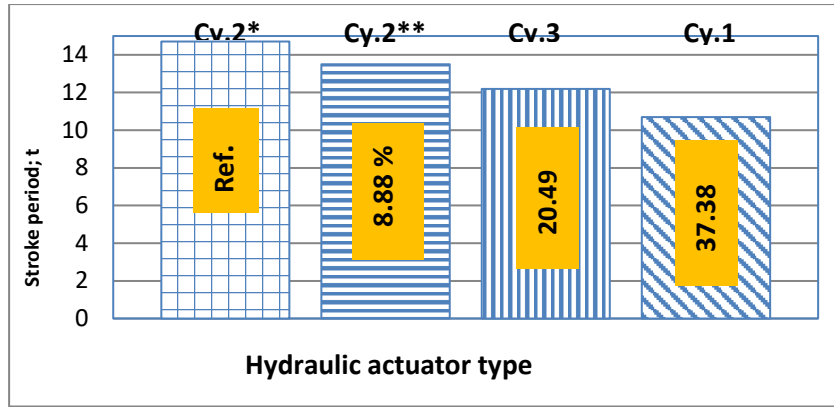

Fig. 9 Relation of system stroke period to supply pressure; $p_s = 50$ bar with variation of hydraulic actuator design, $T = 30$ °C, $W = 5100$ N, $K = 32$ N/mm.

It could be remarked that Cy.1 required time less than other cylinders design in this investigation to achieving the same stroke distance. In circumstances where speed is crucial, using Cylinder 1 can lead to a greater cycle rate, which can improve total productivity.

4.4. Dynamics Performance of the Hydraulic Control System

The present experimental work investigates the effect of system hydraulic actuator - type on the dynamic performance of the fluid power control system.

4.4.1. Effect of hydraulic actuator type on system dynamics

The effect of hydraulic actuator type on system dynamics is investigated. Values of system frequency and displacement amplitude for the variation of hydraulic actuator type which is connected to the system under load; $W = 5100$ N, spring stiffness; $K = 32$ N/mm and supply pressure, $p_s = 10, 20, 30, 40$ and 50 bar at temperature; $T = 30$ °C. Data shown in Table 9, 10, 11 and 12. Results of stroke periods are registered in Tables 9 to 12. Corresponding values in percentage and in dB for displacement amplitude are calculated and presented in the same Tables. Semi-log charts relationship between the amplitude values versus frequency has been plotted in Figs. 10 to 13.

Table 9 System displacement amplitude versus frequency under load; $W = 5100$ N and stiffness; $K = 32$ N/mm at temperature; $T = 30$ °C for different supply pressure values with Cy.1.

p_s , [bar]	Cy.1			Amplitude		
	Stroke	Time of Stroke; t [sec]	Frequency; f ; 1/t [Hz]	X	X [%]	X [dB]
10	Full	77.80	0.012854	185	100	0
	3/4	58.35	0.017138	138.75	75	- 2.498775
	1/2	38.90	0.025707	92.50	50	- 6.020600
	1/4	19.45	0.051414	46.25	25	- 12.041200
20	Full	28.20	0.035461	185	100	0
	3/4	21.00	0.047619	138.75	75	- 2.498775
	1/2	14.10	0.070922	92.50	50	- 6.020600
	1/4	7.00	0.142857	46.25	25	- 12.041200
30	Full	17.50	0.057143	185	100	0
	3/4	13.10	0.076336	138.75	75	- 2.498775

	1/2	8.75	0.114285	92.50	50	- 6.020600
	1/4	4.37	0.228833	46.25	25	- 12.041200
40	Full	13.40	0.074627	185	100	0
	3/4	10.00	0.100000	138.75	75	- 2.498775
	1/2	6.70	0.149254	92.50	50	- 6.020600
	1/4	3.35	0.298508	46.25	25	- 12.041200
50	Full	10.70	0.093458	185	100	0
	3/4	8.10	0.123457	138.75	75	- 2.498775
	1/2	5.35	0.186916	92.50	50	- 6.020600
	1/4	2.70	0.370370	46.25	25	- 12.041200

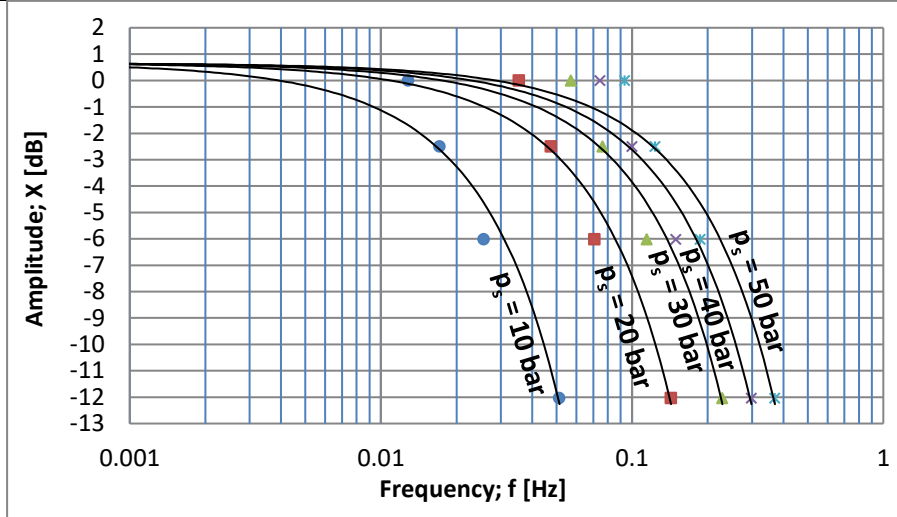

Fig. 10 Relationship of system amplitude; X versus frequency; f for supply pressure; $p_s = 10, 20, 30, 40, 50$ bar under load; $W = 5100$ N, springs; $K = 32$ N/mm, $T = 30$ °C & Cy.1 connection.

Table 10 System displacement amplitude versus frequency under load; $W = 5100$ N and stiffness; $K = 32$ N/mm at temperature; $T = 30$ °C for different supply pressure values with Cy.2*.

p_s , [bar]	Cy.2*			Amplitude		
	Stroke	Time of Stroke; t [sec]	Frequency; f ; $1/t$ [Hz]	$ X $	X [%]	X [dB]
10	Full	106.30	0.009434	185	100	0
	3/4	79.80	0.012531	138.75	75	- 2.498775
	1/2	53.15	0.018815	92.50	50	- 6.020600
	1/4	26.60	0.037594	46.25	25	- 12.041200
20	Full	40.50	0.024691	185	100	0
	3/4	30.45	0.032841	138.75	75	- 2.498775
	1/2	20.25	0.049383	92.50	50	- 6.020600
	1/4	10.15	0.098522	46.25	25	- 12.041200
30	Full	25.30	0.039526	185	100	0
	3/4	19.00	0.053632	138.75	75	- 2.498775
	1/2	12.65	0.079051	92.50	50	- 6.020600
	1/4	6.33	0.157978	46.25	25	- 12.041200
40	Full	18.40	0.054348	185	100	0
	3/4	13.80	0.072464	138.75	75	- 2.498775
	1/2	9.20	0.108696	92.50	50	- 6.020600

	1/4	4.60	0.217391	46.25	25	- 12.041200
50	Full	14.70	0.068027	185	100	0
	3/4	11.10	0.090090	138.75	75	- 2.498775
	1/2	7.35	0.136054	92.50	50	- 6.020600
	1/4	3.70	0.270270	46.25	25	- 12.041200

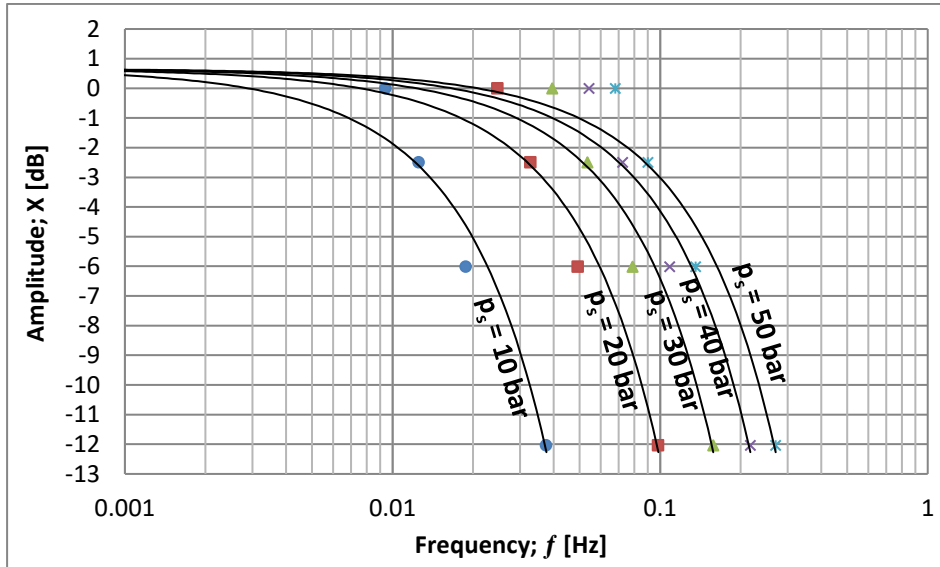

Fig. 11 Relationship of system amplitude; X versus frequency; f for supply pressure; $p_s = 10, 20, 30, 40, 50$ bar under load; $W = 5100$ N, springs; $K = 32$ N/mm, $T = 30$ °C & Cy.2* connection.

Table 11 System displacement amplitude versus frequency under load; $W = 5100$ N and stiffness; $K = 32$ N/mm at temperature; $T = 30$ °C for different supply pressure values with Cy.2.**

p_s , [bar]	Cy.2**			Amplitude		
	Stroke	Time of Stroke; t [sec]	Frequency; f; 1/t [Hz]	X	X [%]	X [dB]
10	Full	79.60	0.012563	185	100	0
	3/4	59.70	0.016750	138.75	75	- 2.498775
	1/2	39.80	0.025126	92.50	50	- 6.020600
	1/4	19.90	0.050251	46.25	25	- 12.041200
20	Full	34.00	0.029412	185	100	0
	3/4	25.50	0.039216	138.75	75	- 2.498775
	1/2	17.00	0.058824	92.50	50	- 6.020600
	1/4	8.50	0.117647	46.25	25	- 12.041200
30	Full	22.00	0.045455	185	100	0
	3/4	16.50	0.060606	138.75	75	- 2.498775
	1/2	11.00	0.090909	92.50	50	- 6.020600
	1/4	5.50	0.181818	46.25	25	- 12.041200
40	Full	16.20	0.061728	185	100	0
	3/4	12.15	0.082305	138.75	75	- 2.498775
	1/2	8.10	0.123457	92.50	50	- 6.020600
	1/4	4.00	0.250000	46.25	25	- 12.041200
50	Full	13.50	0.074074	185	100	0

	3/4	10.20	0.098039	138.75	75	- 2.498775
	1/2	6.75	0.148148	92.50	50	- 6.020600
	1/4	3.40	0.294118	46.25	25	- 12.041200

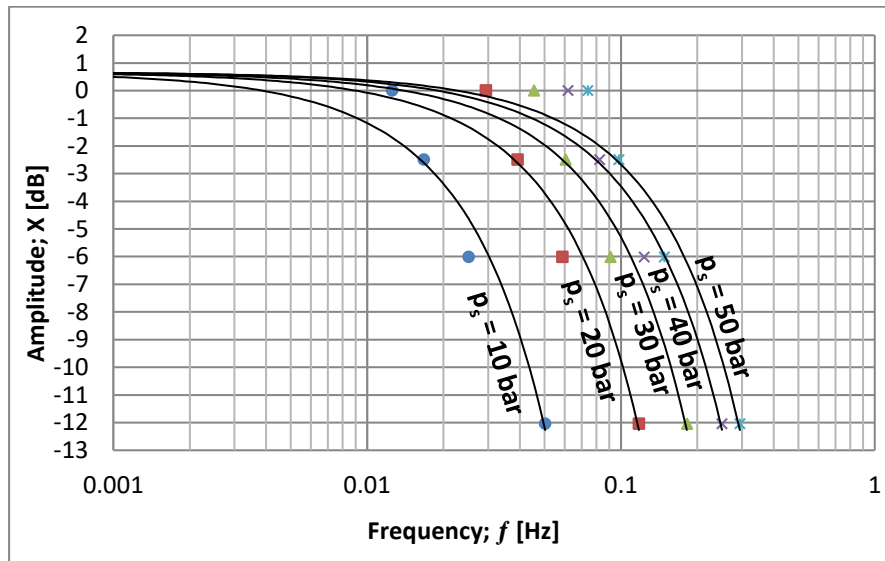

Fig. 12 Relationship of system amplitude; X versus frequency; f for supply pressure; $p_s = 10, 20, 30, 40, 50$ bar under load; $W = 5100$ N, springs; $K = 32$ N/mm, $T = 30$ °C & Cy.2 connection.**

Table 12 System displacement amplitude versus frequency under load; $W = 5100$ N and stiffness; $K = 32$ N/mm at temperature; $T = 30$ °C for different supply pressure values with Cy.3.

p_s , [bar]	Cy.3			Amplitude		
	Stroke	Time of Stroke; t [sec]	Frequency; f; 1/t [Hz]	X	X [%]	X [dB]
10	Full	89.70	0.011148	185	100	0
	3/4	67.20	0.014881	138.75	75	- 2.498775
	1/2	44.80	0.022321	92.50	50	- 6.020600
	1/4	22.40	0.044643	46.25	25	- 12.041200
20	Full	32.50	0.030769	185	100	0
	3/4	24.40	0.040984	138.75	75	- 2.498775
	1/2	16.25	0.061539	92.50	50	- 6.020600
	1/4	8.15	0.122699	46.25	25	- 12.041200
30	Full	21.60	0.046296	185	100	0
	3/4	16.20	0.061728	138.75	75	- 2.498775
	1/2	10.80	0.092593	92.50	50	- 6.020600
	1/4	5.40	0.185185	46.25	25	- 12.041200
40	Full	15.20	0.065790	185	100	0
	3/4	11.40	0.087719	138.75	75	- 2.498775
	1/2	7.60	0.131579	92.50	50	- 6.020600
	1/4	3.80	0.263158	46.25	25	- 12.041200
50	Full	12.20	0.081967	185	100	0
	3/4	9.015	0.110926	138.75	75	- 2.498775
	1/2	6.10	0.163934	92.50	50	- 6.020600

	1/4	3.00	0.333333	46.25	25	- 12.041200
--	-----	------	----------	-------	----	-------------

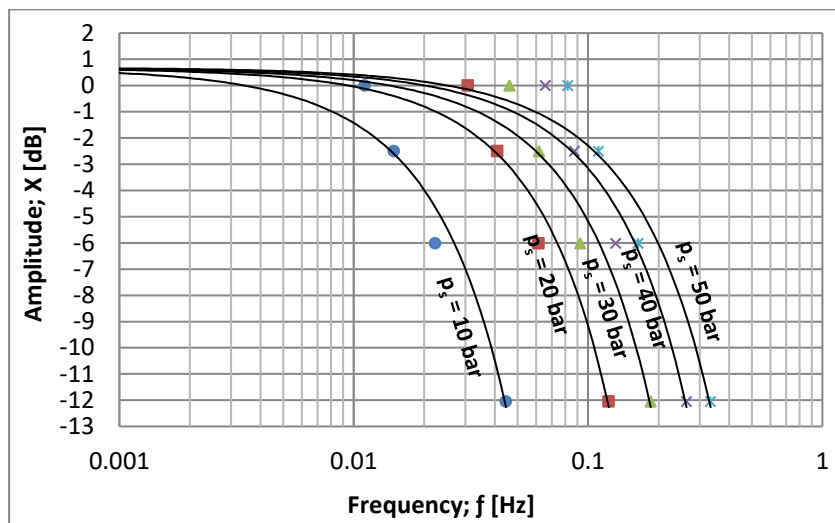

Fig. 13 Relationship of system amplitude; X versus frequency; f for supply pressure; $p_s = 10, 20, 30, 40, 50$ bar under load; $W = 5100$ N springs; $K = 32$ N/mm, $T = 30$ °C & Cy.3 connection.

Comparing the results in Tables 9 to 12 for the same operating conditions of load, supply pressure and temperature, it could be recognized that the frequency of piston displacement decreases with connecting cylinder 2 in forward stroke (Cy.2*) more than with other cylinders, on otherwise the value of frequency increases in case of connecting cylinder 1. For example at $p_s = 50$ bar and full stroke the frequencies are 0.093458, 0.081967, 0.074074 and 0.068027 Hz for Cy.1, Cy.3, Cy.2** and Cy.2* respectively.

In order to discuss the effect of cylinder type on bandwidth frequency, values of bandwidth are extracted at -3 dB from the dynamic curves in Figs. 10 to 13 and recorded in Table 13 and plotted in Fig. 14.

Table 13 System bandwidth frequency for different cylinders design.

Operating Conditions of Bandwidth; B [Hz]	Supply pressure; p_s [bar]				
	10	20	30	40	50
Cy.2*	0.01381	0.03620	0.05830	0.07970	0.09967
Cy.2**	0.01842	0.04313	0.06666	0.09033	0.10852
Cy.3	0.01636	0.04513	0.06789	0.09648	0.12043
Cy.1	0.01885	0.05206	0.08384	0.10962	0.13689
Percentage of Bandwidth Improvement; [%]	36.50	43.81	43.81 %	37.54 %	37.34 %

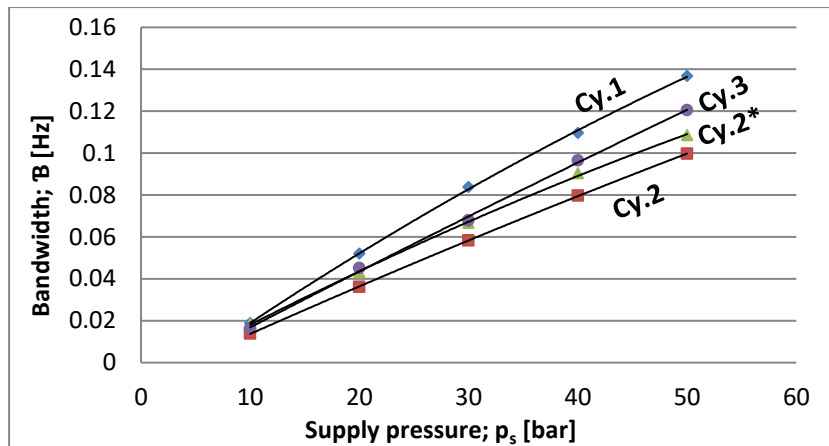

Fig. 14 Relationship of bandwidth frequencies and supply pressure at temperature; $T = 30\text{ }^{\circ}\text{C}$ under load; $W = 5100\text{ N}$, with spring stiffness; $K = 32\text{ N/mm}$ for the different cylinder types.

Cylinder 1 responds more quickly and has more stability in the system since its bandwidth frequency is higher than that of other cylinder types. In order to create hydraulic systems that are dependable and efficient, bandwidth is essential.

CONCLUSIONS

The purpose of this study is to examine linear position control's static and dynamic performance in fluid power control systems. The study uses both theoretical and experimental methods to investigate how system design affects various operating conditions. A servo control valve and several kinds of hydraulic actuators are connected to the system.

1. Connecting the single rod hydraulic cylinder, the system achieves improvement in flow rate in forward stroke by 32.39 % higher than in the backward stroke. While the double rod cylinder achieves higher flow rate than the single rod cylinder in backward movement by 23.12 %.
2. By comparing the operating results under load and without load, it can be observed that when the system's load increases, the flow rate decreases for a certain supply pressure, which in turn lowers the load speed.
3. The actual supply pressure improves in case of connecting the single rod hydraulic cylinder in forward stroke by 53.69 % higher than in the backward stroke. While the double rod cylinder achieves higher actual supply pressure than the single rod cylinder in backward movement by 23.05 %.
4. The frequency of piston displacement decreases with connecting single rod cylinder in forward stroke (Cy.2*) more than with other cylinders. For example at $p_s = 50\text{ bar}$ and full stroke the frequencies are 0.093458 and 0.068027 Hz for the double rod cylinder and the single rod cylinder respectively. The bandwidth frequency is higher by 37.34 %.

REFERENCES

1. El-Din, Mahmoud Galal, and Mohamed Rabi. Fluid power engineering. McGraw-Hill Education, 2009.
2. Merritt H. E., "Hydraulic Control Systems", John Wiley & Sons, Inc., New York, 1967.

3. Y. Li, Y. Shang, X. Wan, Z. Jiao, and T. Yu, "Design, manufacture, and experiments of lightweight CFRP hydraulic cylinder tube without metal liner," *Polymer Composites*, vol. 45, no. 3, pp. 2569–2588, Nov. 2023.
4. D. Padovani, S. Ketelsen, D. Hagen, and L. Schmidt, "A Self-Contained Electro-Hydraulic Cylinder with Passive Load-Holding Capability," *Energies*, vol. 12, no. 2, p. 292, Jan. 2019.
5. S. Mantovani, "Feasibility analysis of a Double-Acting composite cylinder in High-Pressure loading conditions for fluid power applications," *Applied Sciences*, vol. 10, no. 3, p. 826, Jan. 2020.
6. Nostrani, M. P., Silva, D. O. e, Krus, P., & Negri, V. J. D. (2023). A Method for Designing of Hydraulic Actuators Using Digital Hydraulic Pump and Multi-Chamber Cylinder. *Journal of Dynamic Systems Measurement and Control-Transactions of The Asme*, 1–47.
7. Wang, J., Su, K., Wang, R., & Wu, X. (2023, November). Parameter design and simulation verification of leg hydraulic cylinder for quadruped robot. In 2023 3rd International Conference on Robotics, Automation and Intelligent Control (ICRAIC) (pp. 373-376). IEEE.
8. Li, Yao, et al. "Design and experiment on light weight hydraulic cylinder made of carbon fiber reinforced polymer." *Composite Structures* 291 (2022): 115564.
9. Solazzi, Luigi, and Andrea Buffoli. "Fatigue design of hydraulic cylinder made of composite material." *Composite Structures* 277 (2021): 114647.
10. Ding, Shunwei, et al. "Failure analysis of a loader hydraulic cylinder and its end cap structure improvement." *Engineering Failure Analysis* 153 (2023): 107597.
11. Solazzi, Luigi. "Feasibility study of hydraulic cylinder subject to high pressure made of aluminum alloy and composite material." *Composite Structures* 209 (2019): 739-746.
12. Solazzi, Luigi. "Design and experimental tests on hydraulic actuator made of composite material." *Composite Structures* 232 (2020): 111544.
13. Qiu, Zhiwei, et al. "Energy features fusion based hydraulic cylinder seal wear and internal leakage fault diagnosis method." *Measurement* 195 (2022): 111042.
14. Solazzi, Luigi. "Stress variability in multilayer composite hydraulic cylinder." *Composite structures* 259 (2021): 113249.
15. KONGXD, ZHUQX. "Reviews of light weight development of hydraulic components and systems for high level mobile equipment." *Journal of Yanshan University* 44.3 (2020): 203-217.
16. Wang, Jianwei, et al. "Development of a bionic multi-chamber hydraulic cylinder for improving energy efficiency." *Mechatronics* 99 (2024): 103149.
17. Lin, Yonggang, et al. "Multi-cylinder electrohydraulic digital loading technology for reproduction of large load." *Mechatronics* 76 (2021): 102559.
18. Habibi, Saeid, and Andrew Goldenberg. "Design of a new high performance electrohydraulic actuator." 1999 IEEE/ASME International Conference on Advanced Intelligent Mechatronics (Cat. No. 99TH8399). IEEE, 1999.
19. Li, Weijian, et al. "Analysis of and Experimental Research on a Hydraulic Traction System Based on a Digital Hydraulic Transformer." *Sensors* 22.10 (2022): 3624.
20. Sochacki, Wojciech, and Marta Bold. "Damped vibrations of hydraulic cylinder with a spring-damper system in supports." *Procedia Engineering* 177(December 2017): 41-48.

21. Gamez-Montero, P. J., et al. "Misalignment effects on the load capacity of a hydraulic cylinder." *International Journal of Mechanical Sciences* 51.2 (2009): 105-113.
22. Prabel, Robert, and Harald Aschemann. "Comparison of nonlinear flatness-based control of two coupled hydraulic servo cylinders." *IFAC Proceedings Volumes* 47.3 (2014): 10940-10945.

23.

NOMENCLATURE

A	Cylinder flow area	[mm²]
A_n	Nozzle flow	[mm²]
B	Bandwidth	[Hz]
C_d	Discharge coefficient	[%]
D	Cylinder diameter	[mm]
d	Rod diameter	[mm]
f	Frequency	[Hz]
K	Spring stiffness.	[N/mm]
L	Cylinder length	[mm]
p_s	Supply pressure line	[bar]
p_{sa}	Actual value of supply pressure	[bar]
p₁, p₂	Cylinders inlet and outlet pressures	[bar]
Δp	Pressure difference through valve opening	[bar]
Q	System flow rate	[L/min]
Q_c	Flow rate through hydraulic cylinder	[L/min]
Q_n	Flow rate through valve nozzles	[L/min]
T	Temperature	[° C]
t	Time	[sec]
V	Command signal value	[volt]
v	Piston speed	[mm/s]
W	System load	[N]
X	Piston stroke	[dB]
x	Piston displacement	[mm]
ρ	Oil density	[kg/m³]
Φ	Valve opening Percentage	[%]

Abbreviations:

A, B	Working lines
SV	Electro hydraulic servo valve
DC	Direct Current
AC	Alternating Current
Cy.1	Cylinder 1
Cy.2	Cylinder 2 (in forward and backward stroke)
Cy.2*	Cylinder 2 in forward stroke
Cy.2**	Cylinder 2 in backward stroke
Cy.3	Cylinder 3