



Revolutionizing Agriculture With IoT, Mobile Apps, and Computer Vision in Automated Hydroponic Greenhouses

Ahmed M. Hanafi^{1*}, Samaa A. Hussien¹, Donia H. Elnahal¹, Saif Eldin H. Ahmed¹, Mohammed A. Salem¹,
Abdallah R. zainhum¹, Ahmed A. Elsayed¹, Yossef S. Abdel Sattar¹, Mohammed A. Ibrahim¹

¹ Department of Mechatronics Engineering, Faculty of Engineering, October 6 University, 6th of October City, 12585, Giza, Egypt.

* Corresponding author's email: ahmedhanafi.eng@o6u.edu.eg

<https://doi.org/10.21608/ijeasou.2025.346170.1029>

Abstract – This paper investigates the transformative role of automated hydroponic systems in modern agriculture, emphasizing their potential to enhance food production efficiency and sustainability. By integrating IoT, mobile applications, and computer vision technologies, these systems provide precise control over environmental factors, optimizing plant growth conditions. The paper reviews various hydroponic methodologies, including Ebb and Flow, Nutrient Film Technique, and Aeroponics, assessing their applications and effectiveness. Additionally, it explores the integration of data analytics and artificial intelligence to improve decision-making processes in hydroponic environments. Through case studies and literature analysis, the benefits and challenges of implementing automated hydroponics are discussed, highlighting their significance in addressing global food security and environmental sustainability. The findings underscore the importance of innovation in agriculture for sustainable food production.

Received: 20 December 2024

Accepted: 12 January 2025

Published: 12 January 2025

Keywords: Automation, Hydroponics, IoT, Mobile Applications, Computer Vision, Sustainable Agriculture, Food Security, Environmental Sustainability.

I. Introduction

Automated hydroponics stands as a pivotal frontier in modern agriculture, providing a signal of a paradigm shift towards precision, efficiency, and sustainability. This introduction sets the stage for a comprehensive exploration of automated hydroponics, highlighting its transformative potential in meeting the challenges of food security and environmental sustainability.

In recent years, the integration of automation technologies has revolutionized hydroponic cultivation, offering unprecedented control over environmental variables and cultivation parameters. This evolution has propelled hydroponics beyond a niche practice into a widely adopted and accepted approach within the agricultural industry for enhancing crop yields, conserving resources, and mitigating environmental impacts.

This paper shows the significance of automated hydroponics within the broader landscape of agricultural innovation, emphasizing its role in addressing pressing global challenges

such as population growth, climate change, and dwindling arable land. By harnessing the power of automation, hydroponic systems can optimize resource utilization, minimize *waste*, and adapt to dynamic environmental conditions with high precision.

Through a synthesis of current research, technological advancements, and practical implementations, this paper aims to provide a holistic understanding of automated hydroponics. By elucidating its principles, applications, and implications, seeking to inspire further research, innovation, and adoption of automated hydroponic systems for a more sustainable and resilient agricultural future.

A - History of Hydroponics

Hydroponics, the practice of growing plants without soil, has a long and intricate history that predates modern agricultural techniques. Evidence suggests that hydroponics began with ancient civilizations such as the Babylonians, who utilized advanced irrigation systems to water the legendary Hanging Gardens around 600 BC. Similarly, Egyptian hieroglyphs

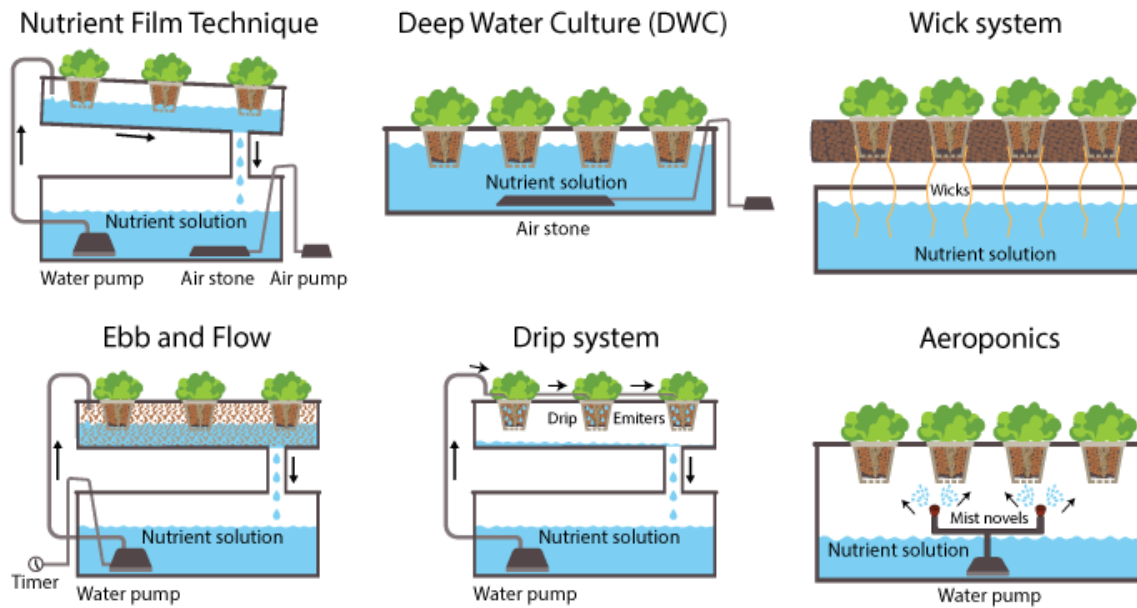

Figure 1: Types of Hydroponic Systems[2]

document soil-less cultivation along the Nile, while the Aztecs developed floating gardens known as *chinampas* in the 10th and 11th centuries.

The scientific foundation of hydroponics evolved over centuries. Early experiments by Greek scientists like Theophrastus and Dioscorides paved the way for soil-less gardening studies. In the 17th century, Sir Francis Bacon's research inspired further exploration into hydroponics, while John Woodward's experiments in the late 1600s highlighted the role of nutrients dissolved in water. Subsequent breakthroughs in the 19th century, such as Nicolas De Saussure's identification of essential mineral elements and Julius von Sachs' nutrient solution formula, formalized the principles of plant nutrition.

The term "hydroponics" was coined in 1924 by Dr. William F. Gericke [1], whose experiments demonstrated the potential for large-scale crop production without soil. His work, though controversial, laid the groundwork for modern hydroponic techniques. During World War II, hydroponics gained prominence as a method to supply food for soldiers in remote locations, with the U.S. military implementing large-scale hydroponic systems on barren islands like Ascension Island.

From the 1950s onward, hydroponics expanded commercially, gaining popularity in countries such as the United States, Germany, and Israel. The method also gained recognition in scientific research, with institutions like NASA exploring hydroponics for space missions under programs like the Controlled Ecological Life Support System (CELSS).

Today, hydroponics is an integral part of sustainable agriculture, addressing challenges like water scarcity and soil degradation. Its applications range from large-scale commercial farms to home gardening systems, underscoring its versatility and importance in addressing global food security issues.

B - Types of Hydroponic Systems

Hydroponic systems provide various methods for delivering water, minerals, and oxygen to plants. The **Ebb and Flow System** [3] uses a medium-like perlite for stability and periodically pumps nutrient solutions into trays for plant absorption, draining excess back into the reservoir. The **Nutrient Film Technique (NFT)** [4] involves sloped channels where the nutrient solution flows over plant roots, which is ideal for plants with large root systems. **Drip Systems** [5] deliver nutrients through smaller tubes directly onto plants, catering to

those with less developed root systems. The **Wick System** [6] relies on materials like perlite or rockwool and nylon ropes to transport nutrients and water from a reservoir to the plants, making it an economical method that does not require pumps. **Aeroponics** [7] is a mist-based system where nutrient solutions are sprayed onto plant roots without a medium, often used in commercial applications. Finally, **Deep Water Culture (DWC)** [8] suspends plant roots in oxygenated nutrient-rich water, with an air pump providing oxygen, offering a low-maintenance setup. These various hydroponic methods cater to different plant types and growing environments, each with its own advantages for specific needs as shown in Figure 1: Types of Hydroponic Systems[2].

Various hydroponic systems employed to deliver nutrient-rich water to plant roots in the study made by Rajendra and Shrinivas [9], including:

1. **Wick Systems:** Passively deliver nutrient solutions to plant roots through wicking action.
2. **Water Culture:** Roots are suspended in a nutrient-rich, oxygenated water solution.
3. **Ebb and Flow Systems:** Plants are grown in an inert medium and periodically flooded with a nutrient solution.
4. **Drip Systems:** Nutrient solution is directly dripped onto plant roots to keep them moist.

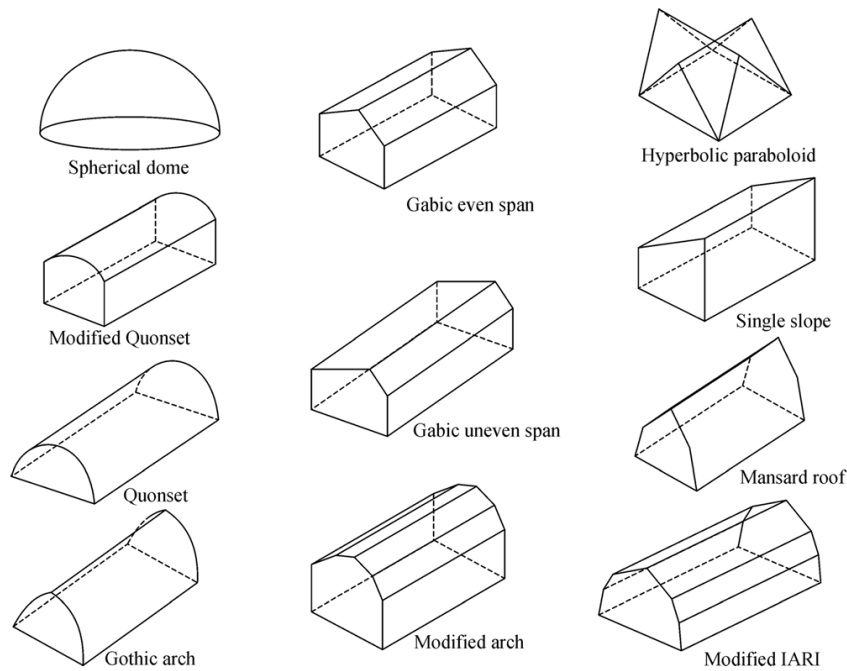

Figure 2: Greenhouses based on different shapes [10].

5. **Nutrient Film Technique (NFT):** A thin film of nutrient solution flows past the bare roots in water-tight channels.
6. **Aeroponic Systems:** Nutrient-loaded mist is used to feed plants, minimizing water usage.

This study emphasizes the potential of hydroponics for enhancing agricultural productivity while minimizing environmental impact and operational costs.

II. Design Innovations

A - Greenhouse Configurations

Recent designs include elliptical and vertical systems to optimize light usage and space. Greenhouse designs vary significantly based on climate, production goals, and structural considerations to optimize crop growth in protected cultivation systems. Hydroponics, particularly vertical farming, requires designs that maximize the use of space while maintaining efficiency in temperature regulation and light penetration. Greenhouses can be categorized into single or multi-span structures and classified based on roof shape, including dome, hyperbolic paraboloid, quonset, elliptical, Gothic arch, mansard, and gable roofs as shown in Figure 2: Greenhouses based on different shapes [10]. Among these, the elliptical (modified quonset) design is particularly advantageous for vertical farming due to its efficient use of interior space, enhanced temperature control, and better accommodation of modern agricultural machinery. Comparative studies indicate that elliptical greenhouses are optimal in terms of solar radiation utilization and productivity, especially in cold climates. Consequently, this design is widely preferred for maximizing agricultural area exploitation and ensuring sustainable year-round vegetable production. [11].

B - Vertical Farming

Innovations like cylindrical hydroponic systems improve planting density and resource efficiency.

The global food supply chain faces numerous challenges, including rapid urbanization, climate change, land degradation, pandemics, biodiversity loss, and the widespread use of pesticides and fertilizers. Consumers are increasingly demanding healthier, locally produced, plant-based food with minimal environmental impact. Additionally, 24% of food is lost before it reaches consumers, often due to quality issues and lengthy supply chains. Vertical farming offers a promising solution to these challenges by improving the production of high-quality, fresh herbs, fruits, vegetables, and flowers. Moreover, vertical farming has the potential to enhance the production of plant-based cosmetic and medicinal products.

Vertical farming systems (VFS) come in various forms, and the terminology can be ambiguous. This review focuses on multi-layer indoor crop production systems that do not rely on solar light, where growth conditions are meticulously controlled. These VFS allow for year-round, consistent production, independent of external weather conditions, ensuring a reliable supply of high-quality products. This controlled environment opens up opportunities for location-independent production from extreme climates such as the tundra and desert to urbanized areas and even outer space.

In comparison to traditional open-field farming, vertical farming offers several key advantages, including guaranteed and uniform quality, lower water and pesticide use, and the potential for minimal food miles. However, it does come with higher energy consumption as shown in Figure 3: Key differences between open-field farming and vertical farming [12]. Vertical farming systems, such as high-tech glasshouses, provide precise control over temperature, light, and CO₂ concentration, enabling high productivity per unit

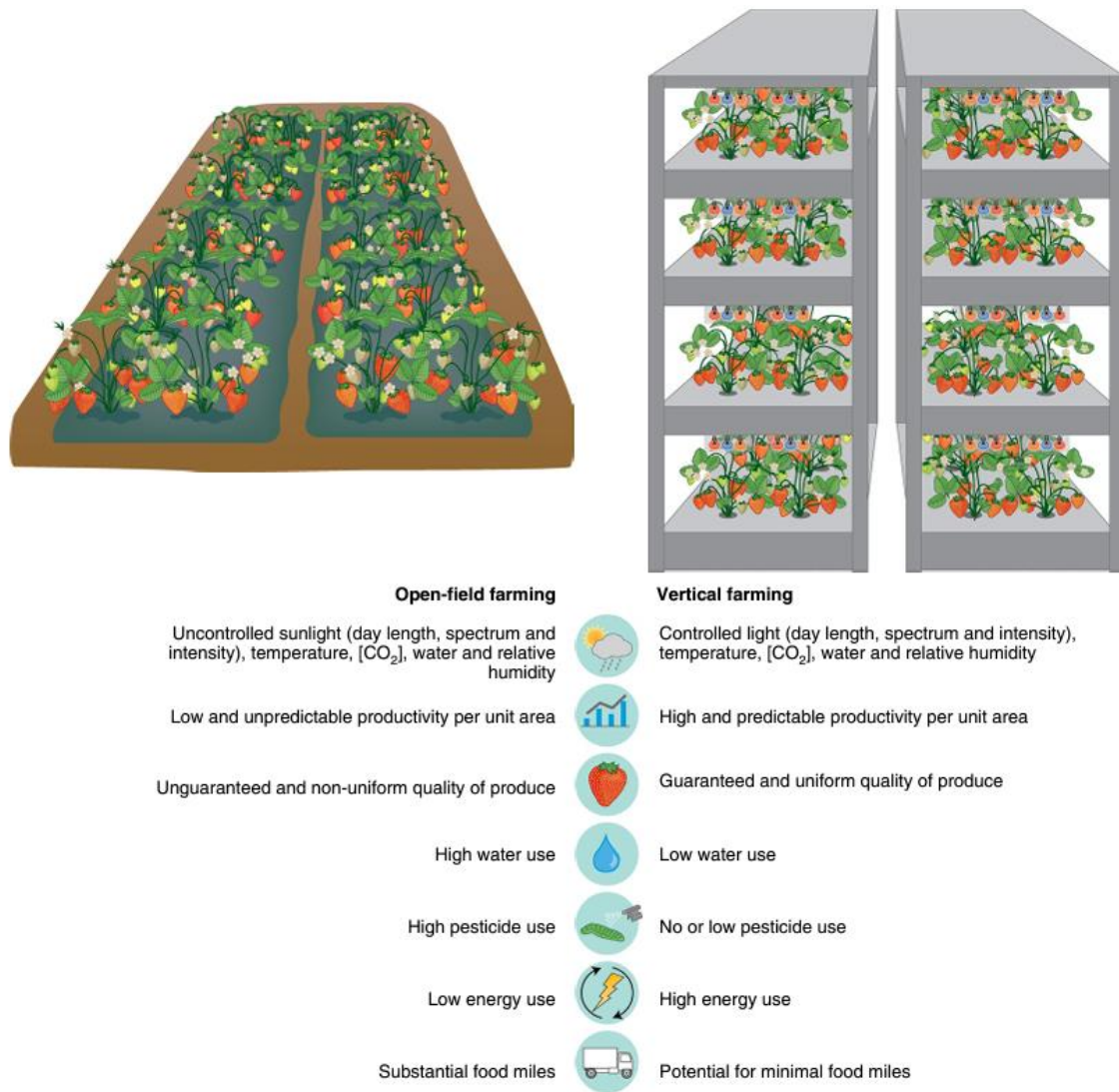

Figure 3: Key differences between open-field farming and vertical farming[12].

area. These systems contribute to the growing movement towards sustainable food production, helping to meet the increasing demand for healthy, locally sourced food with a reduced environmental footprint.

Keat and Kannan developed a multi-tier cylindrical hydroponics system as a vertical farming solution tailored for dense urban environments, such as Singapore, where land is limited. This system, designed for leafy vegetable cultivation, integrates red and blue (RB) LED lighting to optimize plant growth under controlled indoor conditions. Experiments on lettuce (*Lactuca sativa*) and Chinese cabbage (*Brassica chinensis*) revealed that plant growth and yield were influenced by photosynthetically active radiation (PAR) levels and light intensity. Compared to traditional rotary systems, the cylindrical design increased planting density by 47%, enhancing productivity and space utilization. The study highlights the effectiveness of RB LEDs for leafy vegetables, although issues like stem etiolation under low PAR levels were observed. The system demonstrated efficient resource use, with water and nutrients recycled in a closed loop. Despite promising results, further research on LED light intensity, spectral quality, and optimal combinations of light wavelengths is necessary to

maximize growth and adaptability in vertical hydroponics systems [13].

Noureddine Choab et al. investigated the factors influencing the thermal performance and energy needs of greenhouses in Agadir, Morocco, where greenhouse cultivation is rapidly expanding. The study focused on key parameters such as cladding material, shape, orientation, and air change rate, all of which impact energy efficiency. A thermal model developed using TRNSYS software, which incorporated plant presence and evapotranspiration, was validated against previous studies, showing good agreement. The findings revealed that East-West orientation and Quonset shape optimize energy efficiency, reducing air-conditioning costs by 9.28% and 14.44%,

respectively, compared to other configurations. The study also found that using Polycarbonate Hollow Sheets (PHS) as a covering material, instead of 200µm polyethylene (PE), could reduce annual heating demand by 29.2%, while increasing cover thickness reduced heating demand but increased cooling needs. Xenon gas in double PE covers reduced heating demand by 13%, and PVC proved to be the most efficient material for Morocco's climate, saving 2.12% in air-conditioning costs compared to PE. Air as a gap gas in double PE was also found

to be the most cost-effective option. The research concluded that greenhouse design, particularly orientation and material selection, plays a crucial role in improving energy efficiency and reducing operational costs. The study recommends TRNSYS software for accurately simulating greenhouse climates and energy consumption, emphasizing the importance of dynamic plant transpiration models in these simulations[14].

Resham Chawla discussed in this paper the Traditional agricultural methods are associated with several detrimental repercussions, including excessive water waste, poor water management, declining groundwater levels, high land requirements, and soil erosion and degradation. Due to factors such as population growth, urbanization, and industrialization, cultivated land is decreasing, limiting food production. To address this challenge sustainably, alternative methods such as soilless agriculture are being explored. Soilless agriculture, encompassing techniques like hydroponics, offers effective resource management and food production. Hydroponics, a method of growing plants in nutrient solutions, was coined in the early 1930s and has since evolved with advancements such as the Nutri culture system and automated hydroponic systems. Future advancements in hydroponics are expected to leverage technology, integrate with renewable energy sources, optimize for specific crops, and focus on community education and outreach. Despite challenges, ongoing research and innovation in hydroponics promise a more sustainable and resilient future for agriculture[15].

Fabrizio Cumo, et al. discussed in the paper an innovative application of hydroponic greenhouses, which traditionally grow plants without soil using mineral nutrient solutions in water. It proposes the design of a solar greenhouse that can be used for cultivating vegetable species but can also be transformed into a receptive facility through a unique cultivation lifting system. This flexibility allows the greenhouse to serve different purposes, such as events space, accommodations, and agriculture, making it suitable for constrained areas like protected zones where traditional building construction is prohibited.

In Italy, where there are restrictions on building in protected areas, the use of mobile and reversible structures with low environmental impact is permitted. Hydroponic cultivation, although currently less common in Italy compared to Northern Europe, offers numerous advantages, including soilless cultivation, reduced water usage, targeted fertilizer use, and higher productivity. The paper emphasizes the environmental benefits of hydroponics, such as reducing greenhouse gas emissions from transportation and mitigating water scarcity issues. The proposed hydroponic greenhouse solution aligns with the principles of green economy and sustainable development, contributing to Italy's renewable energy production goals. By repurposing unused urban spaces through temporary hydroponic greenhouses, projects like Ur.CA demonstrate how hydroponic structures can serve both agricultural and community needs, enhancing urban environments aesthetically and functionally.

Overall, the paper advocates for the adoption of hydroponic greenhouses as versatile and sustainable solutions for agricultural production, environmental conservation, and community development, particularly in constrained areas like protected zones and urban environments[16].

V. Nikolov, et al. discussed in this paper The study introduces a novel approach to addressing challenges in vegetable production, particularly in regions facing population decline, labor shortages, adverse climate changes, soil degradation, and reduced fertility. It presents the design and implementation of a high-tech, small-scale hydroponic system using IoT technology for growing leafy vegetables.

The system utilizes low-cost materials and sensors for remote monitoring and process automation during the cultivation of leafy vegetables and seedlings.

Experimental investigations with lettuce as the cultivated crop demonstrate that the system maintains optimal environmental and technological parameters, including air temperature, air humidity, and pH of the nutrient solution.

Advantages of the proposed hydroponic system include its simplicity of management, easy installation, and the possibility for remote monitoring and control, making it suitable for small and medium-sized vegetable growers. The system offers year-round sustainable farming of leafy vegetables indoors, overcoming challenges such as labor shortages and adverse climatic conditions.

The study also discusses the broader context of population migration from rural to urban areas, the shift in agricultural practices towards vegetable production, and the impacts of climate change on traditional farming methods. It highlights the need for new intensive approaches to vegetable production, such as hydroponics, to ensure food security and sustainability.

Furthermore, the study explores the application of IoT technology in agriculture, citing examples of IoT-based hydroponic systems for monitoring and optimizing environmental conditions. It emphasizes the potential of IoT devices, sensors, and data analysis for improving the efficiency and productivity of hydroponic systems. Future research aims to design a larger-scale hydroponic system capable of controlling a total area of 60 m² and conducting experiments with different vegetable crops. Additionally, a cost-benefit analysis will be performed to evaluate the profitability of the system for indoor vegetable growing under Bulgaria's climate conditions. The study concludes with acknowledgments to contributors and funding sources, declaring no conflicts of interest, and provides information on data availability [17].

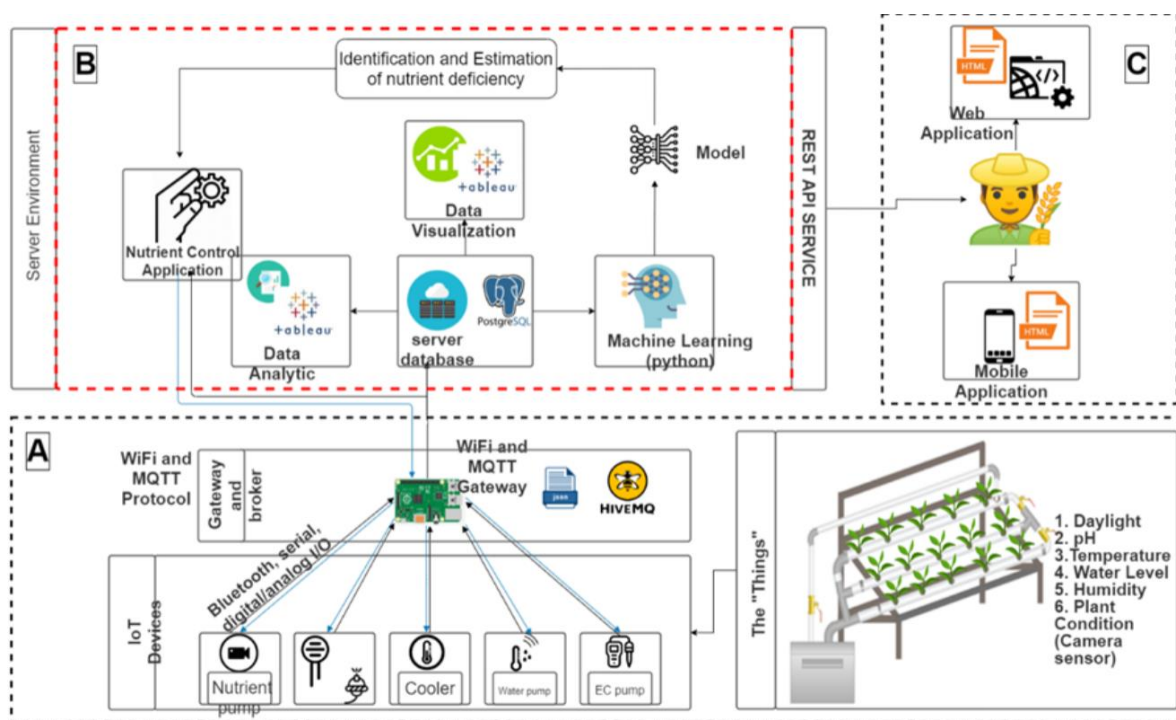

Figure 4: Smart Hydroponics Design System [18].

C - Characteristics of Solar Radiation Effects on Greenhouse Operations

Solar radiation plays a critical role in greenhouse operations, influencing both plant growth and the overall energy dynamics within the structure. Key characteristics of solar radiation and its effects include:

Light Intensity and Photosynthesis: Solar radiation provides the energy required for photosynthesis, the process by which plants convert light into chemical energy. Adequate light intensity is essential for optimal crop growth, while insufficient light can hinder photosynthetic activity, reducing yield and quality.

Thermal Effects: Solar radiation contributes to the heating of greenhouses. Transparent covering materials allow sunlight to enter, trapping heat inside through the greenhouse effect. This natural heating reduces the reliance on artificial heating systems during the day, particularly in colder climates, but can lead to overheating during peak sunlight hours in warmer regions.

Impact on Humidity and Ventilation: The thermal effects of solar radiation influence greenhouse humidity levels by increasing water evaporation and transpiration from plants. Proper ventilation systems are critical to managing these changes, preventing excessive humidity that could foster disease or mold growth.

Selection of Covering Materials: The type and quality of greenhouse coverings, such as glass or polyethylene, affect the transmission and diffusion of solar radiation. Materials with high light transmission and appropriate spectral filtering optimize the light spectrum for plant growth while minimizing excessive heat.

Daily and Seasonal Variability: The intensity and angle of solar radiation vary throughout the day and across seasons. Greenhouse designs must account for these variations by incorporating adjustable shading systems, thermal screens, or energy storage mechanisms to regulate internal conditions effectively.

Energy Efficiency and Renewable Integration: Utilizing solar radiation for passive heating and integrating photovoltaic panels can enhance the energy efficiency of greenhouses. These approaches reduce dependency on external energy sources while supporting sustainable agricultural practices.

Simulation of Solar Radiation Using Software: Advanced simulation tools like DesignBuilder and EnergyPlus enable precise modeling of solar radiation impacts on greenhouse environments[19]. These tools allow researchers and designers to evaluate the effects of solar radiation on internal conditions, optimize greenhouse designs, and assess energy-saving strategies. By simulating factors such as light intensity, heat distribution, and ventilation, these software solutions facilitate informed decision-making for enhancing greenhouse performance and sustainability.

Using AI for Energy Management in Greenhouse Technology

Understanding and managing the characteristics of solar radiation is essential for designing and operating greenhouses effectively, ensuring optimal growing conditions while minimizing energy consumption.

D - Using AI for Energy Management in Greenhouse Technology

Artificial intelligence: The integration of artificial intelligence (AI) into greenhouse technology offers innovative solutions for

optimizing energy management. AI-driven systems utilize advanced algorithms and real-time data from IoT sensors to regulate critical environmental parameters such as lighting, temperature, humidity, and CO₂ levels. By dynamically adjusting energy inputs based on weather conditions, crop needs, and operational demands, these systems significantly reduce energy waste while ensuring optimal plant growth. Predictive models powered by AI can forecast energy consumption and manage resources more effectively, contributing to cost savings and sustainability. Furthermore, AI enhances equipment efficiency through predictive maintenance, preventing downtime and extending the lifespan of essential systems. This transformative approach not only improves the energy efficiency of greenhouse operations but also aligns with global efforts toward sustainable agriculture and environmental conservation[20].

I. IoT and Mobile Applications

AD Ashok and E Sujitha discussed in The paper "Design of an Intelligent Hydroponics System to Identify Macronutrient Deficiencies in Chili" proposes an advanced hydroponic system integrating Internet of Things (IoT) technology and computer vision to address macronutrient deficiencies in chili plants as shown in Figure 4. This intelligent system leverages RGB image analysis and Multi-Layer Perceptron (MLP) architecture to identify and estimate nutrient deficiencies with greater precision. By utilizing visual features such as leaf texture, color, and shape, the system can differentiate between nutrient deficiencies that exhibit similar symptoms. This research emphasizes the significance of combining classification and regression tasks to provide actionable insights for farmers, enabling precise nutrient management in hydroponic setups. The proposed model is tailored for chili plants but demonstrates potential scalability for broader agricultural applications, particularly in precision farming systems in Indonesia. The study's innovative approach highlights its applicability in overcoming challenges in limited agricultural land and unpredictable environmental conditions. [18].

IoT technology has become a cornerstone in monitoring environmental conditions in hydroponics. Mobile applications facilitate remote management, enhancing the user's ability to control essential parameters like humidity, temperature, and nutrient supply.

Nahla Sadek, Noha Kamal, Dalia Shehata discussed in this paper the development and implementation of a smart hydroponic and aeroponic greenhouse system utilizing IoT technology to optimize growing conditions for Batavia lettuce. This system automates weather control and monitors various parameters like temperature and humidity. Results show significant improvements in water and energy efficiency, productivity, and reduced cultivation time compared to traditional methods. Overall, the smart system enhances agricultural sustainability while minimizing labor and resource use.

The text highlights the urgency to address hunger and poverty while ensuring agricultural sustainability. Hydroponic and aeroponic systems are proposed as effective alternatives for Egypt's growing population. Automation of these systems in

smart greenhouses has shown promising results globally. Challenges like environmental control inside greenhouses persist, but IoT technology offers solutions through continuous monitoring. The paper introduces a smart architecture for hydroponic and aeroponic systems, emphasizing sensor-based control of humidity and temperature to optimize plant growth. The study evaluates the system's impact on cultivating Batavia lettuce, demonstrating improved water and fertilizer efficiency, faster growth, and reduced cultivation time compared to traditional methods. Moreover, the system saves water, energy, and labor while reducing the need for fertilizers and pesticides. Future research aims to explore renewable energy sources and desalinate water for these systems, with cost comparisons essential for decision-making [21].

Usman Nurhasan, et al. discussed in this paper that Hydroponics, a soil-less cultivation method, emphasizes meeting plants' nutritional needs through water. Deep Flow Technic (DFT) is a hydroponic method with continuous nutrient flow, yet inadequate maintenance of growth factors like water circulation, light, temperature, humidity, and pH can hinder plant growth. Monitoring and controlling water circulation in DFT-based hydroponics are essential. Raspberry Pi-integrated sensors gather data on plant growth factors, displayed on a website. Fuzzy Sugeno Method processes temperature and humidity for water circulation control. Tests confirm real-time monitoring and automatic water circulation control, enhancing mustard green growth significantly. Hydroponics offers urban agricultural solutions, utilizing limited space efficiently. The IoT facilitates communication among objects, applicable to both soil-based and hydroponic agriculture. The system designed in this project effectively monitors and controls DFT hydroponic systems, ensuring optimal plant growth conditions[22].

Pavan Koge, et al. discussed that, In India, agriculture serves as the backbone of the nation, yet faces various challenges such as small land holdings, dependence on chemical inputs like manures and pesticides, and increasing consumer demand for healthier, pesticide-free food. Our proposed solution addresses these issues by promoting organic farming through controlled environments using IoT technology. This method allows for efficient monitoring and control of essential plant requirements, enabling cultivation in diverse settings such as rooms, terraces, and balconies, maximizing space utilization. Hydroponics, a soil-less farming technique utilizing nutrient-rich water, has gained popularity due to its eco-friendly nature and high productivity potential. This system not only offers urban dwellers access to fresh vegetables but also benefits home and commercial growers by reducing the labor and time associated with traditional soil-based cultivation. With the advancement of technology and the rise of smart lifestyles, our IoT-based hydroponic system facilitates real-time monitoring and control of environmental factors crucial for plant growth, such as temperature, humidity, light intensity, and pH levels. This approach revolutionizes agriculture by providing a lifeline for crop production in areas with limited land availability, enabling cultivation in greenhouses, rooftops, and multi-tiered buildings. Hydroponics offers a solution for individuals lacking garden space or struggling with pests, allowing them to establish successful home gardens with minimal investment. Overall,

hydroponics represents a sustainable and efficient agricultural method capable of surpassing traditional soil-based cultivation in terms of plant growth rate and resource utilization[23].

Asawari Dudwadkar, et al. discussed that, in today's health-conscious society, India's pursuit of fitness drives a demand for healthier food options. However, urban vegetables are often contaminated with pesticides, posing risks to health and the environment. Organic farming, while desirable, faces challenges due to high costs. Our proposed solution integrates hydroponics with a designed system to offer a sustainable alternative to conventional farming. This hydroponic system ensures higher growth rates and controlled environments, reducing the labor-intensive tasks associated with traditional farming. Additionally, remote monitoring and control of environmental factors allow for year-round availability of plants and vegetables, independent of natural conditions. Hydroponics, the process of growing plants without soil using nutrient solutions, promotes healthy growth and higher yields. By mitigating the constraints of traditional farming and enabling close monitoring and control of plant environments, our system caters to the demands of urban India and contributes to mass production while also benefiting small-scale cultivators and individuals.

Through automation and IoT integration, our system streamlines the hydroponic process, making it more efficient and self-sufficient. The software interface displays crucial parameters such as temperature, humidity, and pH levels on smartphones, enhancing ease of monitoring. Overall, hydroponics, coupled with our innovative system, offers a viable solution to meet market demands and can replace traditional farming methods on desired scales [24].

Prathima V.R1, Vandhana Shree G S2, Lavanya R3, Mounika J4 made a project utilizes hydroponics, a soilless plant-growing technique, with a focus on water conservation. Sensors connected to an ESP32 monitor nutrient supply essential for plant growth. Internet of Things (IoT) technology is employed to regulate temperature, humidity, pH levels, water flow, and nutrient supply. Maintaining correct pH levels, air temperature, humidity, and nutrient levels is crucial in hydroponics. Users can control mechanisms such as refilling, sprinkling, and draining via a web application. Additionally, they can monitor pH levels, humidity, and water levels using data collected from sensors.

Agriculture is vital for human sustenance, economic development, and job creation, but traditional farming methods often result in low yields. Implementing modern technology and automation can significantly improve crop yield and reduce labor. Remote sensor networks are commonly used to collect environmental data, which is then transmitted to a main server for monitoring and analysis. However, simply monitoring environmental factors is not enough to enhance crop yield; automation is necessary. Automation can address various factors affecting productivity, such as pest attacks and postharvest issues. To tackle these challenges, an integrated system is required to manage all stages of farming effectively. This project focuses on automating hydroponics farming, including automatic water supply, temperature and pH level

maintenance, sunlight regulation, and alerts for unusual conditions. Information is displayed on a panel and sent to the farm owner for monitoring and management.

The study on Smart Hydroponics, which operates automatically with the assistance of ESP32 and various sensors, has been successful in creating a fully controlled hydroponic system. This system is highly adaptable and can be implemented in any region, including small areas. Comparing Smart Hydroponics with traditional farming methods, it has been found that hydroponics yields more produce while requiring less water and pesticides, as it provides all necessary nutrients directly to the plants[25].

S. V. S. Ramakrishnam Raju , et al.explored the integration of Internet of Things (IoT) technology in hydroponic farming to address agricultural challenges such as harsh weather, soil erosion, and resource depletion. Despite its potential, traditional farming faces ongoing obstacles like climate change, pollution, and urbanization, pushing the need for innovative farming methods like hydroponics and vertical farming. However, hydroponics faces challenges such as seedling problems, system clogging, and nutrient deficiencies, which require constant monitoring and intervention. IoT enables real-time data collection, facilitating decision-making and enhancing agricultural productivity and sustainability.

The paper introduces AI-SHES, an IoT-based system that incorporates Raspberry Pi, a mobile application, and cloud computing to manage hydroponics farms. This system allows for both manual and automated control of farm conditions, providing a user-friendly interface for farmers. The IoT platform gathers sensor data and sends it to the cloud, where an AI framework powered by deep learning convolutional neural networks (DLCNN) analyzes the data for plant health monitoring and disease prediction. The Agri-Hydroponic app alerts farmers based on the analyzed data, allowing for timely intervention. The system is designed to optimize nutrient delivery, offering both manual adjustments by farmers and automated nutrient application. Further enhancements, such as the integration of hybrid deep learning models and optimization techniques, are proposed to improve system functionality and expand its capabilities.

The research underscores the transformative potential of IoT and AI in hydroponic farming but also highlights the need for ongoing innovation and proactive management to overcome the evolving challenges of modern agriculture[26].

Farah Hanan Azimi et al. presented the development of an intelligent hydroponic system utilizing the Nutrient Film Technique (NFT) and the Internet of Things (IoT) to enable real-time monitoring and management of crop systems. The system uses sensors to monitor key parameters such as pH, electrical conductivity (EC), temperature, and flow rate, which are essential for optimal hydroponic growth. The data collected by these sensors is transmitted to an IoT system, allowing for real-time tracking and adjustments via the BLYNK mobile application, which serves as the user interface.

Hydroponic farming, which does not rely on soil and uses nutrient-rich water for plant growth, has gained popularity in urban agriculture for its efficiency and space-saving capabilities. The NFT system, a key method in hydroponics, circulates the nutrient solution around the plant roots, ensuring continuous plant production in a controlled environment. This system aims to improve self-sustainability by enabling users to grow their own food with control over the planting process, ensuring high yields and quality crops.

The system specifically focuses on monitoring and adjusting the pH and EC levels of the nutrient solution for lettuce cultivation. The real-time data acquisition provided by the IoT system allows users to make informed decisions and make necessary adjustments to optimize plant growth, thus increasing productivity. Future improvements could include the integration of industrial-grade sensors to address issues related to sensor calibration and durability, enhancing the system's reliability for long-term use in hydroponic farming[27].

Sihombing, et al. founded that the integration of computer science and agriculture has become increasingly common, with both fields complementing each other. This paper aims to develop an automated control tool for hydroponic plant nutrient flow using an Arduino microcontroller, controllable via smartphone. An Arduino Uno microcontroller is employed to automate nutrient solution flow using logic programming. The microcontroller collects data on fluid level and temperature using an Ultrasonic sensor HC-SR04 and a temperature sensor LM35, respectively. This data is displayed on a liquid crystal display (LCD) and transmitted to an Android smartphone via a WIFI ESP8266 module. Plant care, including watering and fertilization, is crucial for maintaining plant health, especially for hydroponic plants relying on water for nutrients. With various types of planting media, such as Rockwool and coconut powder, the timing of watering and nutrient replacement is essential but can be inconvenient for plant owners with numerous hydroponic plants. Automating the watering system using microcontrollers offers a solution to this issue. The described project utilizes an Arduino Uno microcontroller to monitor hydroponic plants, detect water levels using a proximity sensor, and measure temperature using sensors. The collected data is transmitted to an Android smartphone, allowing users to monitor and control the system remotely. The system successfully maintains water levels in hydroponic tubes and adjusts them as needed. Future research could focus on detecting additional parameters such as pH levels and viscosity, as well as scaling up the automation system. Additionally, expanding compatibility to other operating systems for real-time monitoring is recommended for advanced research in this field[28].

Aman Pache, et al. explored the growing demand for healthier food options due to concerns about harmful chemicals in commercial crops. Hydroponics, a soil-free method of crop cultivation, offers a sustainable solution by providing essential nutrients through water. To meet the needs of busy consumers and those moving away from traditional farming, automated hydroponic systems have been developed. These systems use sensors to monitor and control critical parameters such as

temperature, humidity, electrical conductivity, and light, ensuring optimal conditions for plant growth.

Grow lights are incorporated to support indoor cultivation, particularly in regions with unfavorable climates, and various hydroponic systems are designed to maximize water, energy, space, and cost efficiency. Nutrient dosing systems are employed to deliver the necessary nutrients for plant health, while sensors continuously track and adjust environmental conditions. Some systems also integrate camera modules to detect plant diseases and provide real-time updates through mobile applications or websites.

This review highlights the integration of Internet of Things (IoT) technology in automated hydroponic systems, aiming to enhance plant growth and address the increasing consumer demand for healthier, chemical-free crops. The proposed designs seek to overcome the limitations of existing systems, improving functionality and efficiency[29].

Kajal Kumari, et al. presented the design and implementation of a smart hydroponics greenhouse system utilizing IoT technology to address the challenge of meeting the growing global food demands. Hydroponics, a method of growing plants without soil using nutrient-rich water, is optimized in this system by controlling essential environmental factors such as temperature, humidity, pH, TDS (Total Dissolved Solids), and light levels.

The system incorporates an Arduino Mega2560 controller, along with sensors to monitor environmental conditions, and actuators to control pumps, lights, fans, and valves. An ESP-01 module ensures internet connectivity, enabling real-time data collection of various parameters like temperature, humidity, TDS, pH, light, and actuator status. This data is stored and accessed via Firebase, and a mobile application facilitates remote monitoring and control of the greenhouse.

By integrating IoT, the greenhouse becomes a "smart" environment, offering benefits such as extended growing seasons, protection from pests and diseases, and the ability to produce high-quality crops without the use of pesticides. The study successfully developed and tested the system, demonstrating accurate monitoring and control capabilities. Future research will focus on enhancing the system by incorporating artificial intelligence to enable automated management and monitoring, further optimizing the efficiency and sustainability of hydroponic farming[30].

Asawari Dudwadkar, et al. addressed the challenges faced by conventional farming in urban India, particularly pesticide contamination and soil degradation, by promoting hydroponic systems with controlled environments and remote monitoring capabilities as a sustainable alternative. The study highlights the growing health consciousness in urban areas, where consumers are increasingly concerned about the health risks associated with pesticide-laden vegetables.

Hydroponics is presented as a solution that produces healthier vegetables without the use of soil, thus minimizing pesticide risks and soil degradation. The system offers advantages such

as higher growth rates and yields compared to traditional farming methods by directly supplying nutrient solutions to plant roots and regulating atmospheric conditions.

Incorporating Internet of Things (IoT) technology, the hydroponic system enables automation and remote monitoring, reducing labor-intensive tasks and providing producers with real-time environmental data. The system is designed to meet the increasing demand for fresh, exotic vegetables in urban markets and is scalable for both large-scale producers and smaller, individual cultivators.

The integration of hardware components like sensors and actuators with software applications allows users to monitor and control the system via smartphones, ensuring optimal growing conditions. The paper underscores the potential of hydroponic technology, automation, and IoT in revolutionizing urban agriculture, providing a sustainable solution to food production while meeting the diverse needs of both producers and consumers [24].

Ravi Lakshmanan, et al. discussed the design and implementation of an automated smart hydroponics system utilizing the Internet of Things (IoT) to address global food demands and the need for sustainable farming methods. The system integrates components such as Nedelcu, Node-RED, MQTT, and various sensors, which monitor key environmental parameters and transmit data to the cloud for real-time processing and monitoring. Data is accessible through both a web page and a mobile application, offering remote access to system performance. A boat was also introduced for supply chain control and notifications, enhancing system functionality.

Hydroponics, a soil-free farming method, is recognized for its higher productivity compared to traditional farming. The integration of IoT in hydroponic systems, using platforms like Things Speak and communication protocols like ZigBee, has been shown to improve productivity and water conservation. The proposed system monitors parameters such as water level, pH, temperature, and humidity, providing a user-friendly GUI for remote operation hosted on a secure cloud platform. This system reduces maintenance costs, enhances operational efficiency, and simplifies the hydroponic farming process.

Future enhancements are focused on incorporating data science and artificial intelligence for crop enhancement, as well as developing an end-user platform to further streamline system interaction. Additionally, the integration of machine learning algorithms for predictive analysis and advanced microprocessors for crop health monitoring are anticipated to significantly improve system performance and sustainability in hydroponic farming[31].

Suhan M., et al. proposed an integrated Internet of Things (IoT) framework for managing and controlling hydroponic gardens, addressing the challenges of resource management in modern farming. The system aims to create an optimal environment for plant growth by continuously monitoring key parameters such as pH, water level, air temperature, and relative humidity. It employs sensors to collect real-time data, which is processed via cloud-based technology to regulate irrigation and nutrient

intake, ensuring a balanced and controlled environment for plant development.

The study highlights the inefficiencies of traditional, manual methods of crop cultivation and the advantages of automated systems in improving farming outcomes. By integrating smart farming technologies, the system can automate the monitoring and control of critical parameters, reducing variations in sensor data and providing timely feedback to farmers. This approach not only enhances resource management but also results in higher-quality crops compared to conventional farming techniques. The success of the system demonstrates the potential of IoT in improving hydroponic farming, with future enhancements such as temperature and humidity control mechanisms, tailored to specific plant species, further increasing efficiency and yield quality[32].

Ajit Dundappa Chachadi and G.R. Rajkumar discussed the integration of Internet of Things (IoT) technology into hydroponic cultivation, offering a solution to the challenges posed by rapid urbanization, population growth, and water scarcity. The proposed system utilizes a combination of sensors, actuators, and microcontroller units to remotely monitor and control hydroponic farms. Central to the system's architecture are the Arduino Uno microcontroller, Raspberry Pi 4B microcomputer, and various sensors, which collect data on key parameters like pH, electrical conductivity (EC), temperature, humidity, and water flow. The data is processed through a decision tree algorithm running on the Raspberry Pi, which then activates specific actuators to regulate the farm environment.

An Android mobile application is developed to facilitate remote monitoring, allowing farmers to manage hydroponic farms from anywhere. The system has been tested in the context of lettuce farming, where it successfully maintained optimal parameters for growth. The system's average values for pH, EC, temperature, and humidity were found to be 5.86, 2.21 mS/cm, 26.95°C, and 66.85%, respectively. The study demonstrates the effectiveness of IoT in enhancing hydroponic farming by improving plant yield, reducing maintenance costs, and enabling efficient management of large-scale farms. This system represents a significant advancement in autonomous farming, providing real-time data for informed decision-making and optimized resource use[33].

Iswanto, et al. explore the use of the Nutrient Film Technique (NFT), a hydroponic method for cultivating plants without soil, where plant roots are submerged in shallow, circulating layers of nutrient-rich water. The system ensures plants receive optimal water, nutrients, and oxygen for growth. The NFT method involves using polyethylene layers to support plant roots while a pump circulates nutrient solutions, ensuring continuous nourishment. The paper focuses on the design and automation of this process using an Arduino microcontroller to regulate nutrient composition and control the pump circulation.

The study highlights the increasing popularity of hydroponics and the advantages of the NFT system, particularly its ability to automate cultivation and reduce the need for constant monitoring. By integrating Arduino technology, the NFT system becomes more efficient and easier to manage, providing

growers with precise control over plant nutrition and optimal growth conditions. The paper is organized into sections, including an introduction to hydroponics and the NFT system, a theoretical overview of key components like the Arduino Uno microcontroller, ultrasonic sensors, pH meters, and peristaltic pumps, as well as a detailed methodology for designing and implementing the automated NFT system.

The experimental setup includes the use of an Arduino Uno microcontroller board, relay modules, sensors, and pumps. The system was tested with cayenne pepper plants, which took about nine weeks to grow from seedling to flowering. While the system's automation proved effective in regulating nutrient circulation, certain limitations were identified, such as the requirement for high water pressure in the solenoid valve system, making it unsuitable for low-pressure scenarios. Despite these challenges, the research demonstrates that Arduino-controlled NFT systems can simplify hydroponic farming, though further improvements are necessary to address water pressure issues and enhance the system's versatility across different environments. The paper concludes by emphasizing the potential of automated NFT systems for advancing agricultural practices through increased efficiency and reduced labor requirements[33].

Xin Zhang et al. investigates the impact of light intensity, photoperiod, and light quality on lettuce growth and quality in closed plant factories. Using a combination of fluorescent and LED lamps with varying red-to-blue (R:B) light ratios, the research evaluates parameters such as growth, photosynthesis, quality, and energy use efficiency. The findings suggest that the optimal conditions for indoor lettuce production involve a photosynthetic photon flux density (PPFD) of $250 \mu\text{mol}/\text{m}^2\cdot\text{s}$ with a 16-hour daily photoperiod, using LED lighting with an R:B ratio of 2.2.

Indoor controlled environments such as plant factories have become increasingly popular for commercial leafy vegetable production, with lettuce being a favored crop due to its short growth cycle and low energy needs. LEDs are preferred in these settings due to their energy efficiency and effectiveness in promoting plant growth compared to other light sources such as fluorescent lamps and high-pressure sodium lights. Various studies have explored the effects of light quality and intensity on lettuce growth, but optimal conditions for maximizing growth and quality are still being refined.

This research highlights the challenges of balancing energy efficiency with yield in commercial lettuce production. While lower light intensities are sometimes used to save power, they can result in reduced yields. The study emphasizes the importance of determining the optimal lighting conditions to maximize light use efficiency (LUE) and economic returns. The recommended conditions— $250 \mu\text{mol}/\text{m}^2\cdot\text{s}$ PPFD with a 16-hour photoperiod and an LED R:B ratio of 2.2—are found to be ideal for maximizing both lettuce yield and quality in hydroponic systems. However, further investigation into LED performance, including luminous efficiency and lifespan, is necessary to improve the overall effectiveness of indoor lettuce production systems [34].

Vaibhav Palandea, et al. designed The Titan Smartponics system is a fully automated hydroponic solution designed to facilitate indoor plant growth while mitigating the impact of external weather conditions. By utilizing hydroponics, a soil-less cultivation technique, the system enables the growth of common plants and vegetables regardless of the outside climate. The system minimizes human intervention by integrating microcontrollers, sensors, and IoT technology, allowing for remote monitoring and control. Users only need to plant seedlings and set initial parameters, after which the system autonomously maintains the ideal conditions for plant growth.

Unlike traditional hydroponic systems that regulate only a limited set of parameters, Titan Smartponics monitors and controls all essential factors required for optimal plant development. This system offers a more comprehensive and affordable alternative to existing automated hydroponic setups, which can be expensive or lack complete parameter control. Data is collected and analyzed through Domoitcz software, providing valuable insights into temperature, lighting, water temperature, and pH levels. A four-week comparison of plant growth inside and outside the system shows enhanced growth characteristics, such as improved leaf color, size, and stem length.

By leveraging technologies like Arduinos, Raspberry Pi, open-source software, and various sensors, Titan Smartponics provides a reliable, fully automated solution for indoor hydroponic cultivation. Its key benefits include precise control over growth conditions, adaptability to different plant species, and independence from external environmental factors, making it an accessible and cost-effective option for consumers[35]

Sonia Senil and Lukman Audahl present an innovative solution combining hydroponic and vertical farming techniques, aimed at enhancing urban agriculture through automation and technology. As global food systems face challenges like food waste and environmental concerns, producing our own food locally becomes a sustainable alternative. The project focuses on growing Chinese cabbage (Pak Choy) using the Float and Drain technique in a vertical hydroponic system, controlled via the Blynk app. This system reduces the need for manual intervention, while providing real-time monitoring and control of crucial variables like nutrients, water, light, and ambience through a smartphone.

The system is powered by an Arduino Wi-Fi UNO ESP8266 WeMos D1 and is equipped with sensors such as the DHT11 for temperature and humidity, the HC-SR04 for monitoring water and nutrient levels, and a pH sensor for managing the water's pH balance. These sensors are integrated with the Blynk IoT platform to enable remote monitoring and management of the system, making it ideal for urban farmers with limited space. The vertical farming setup offers a space-efficient solution that allows for year-round cultivation in areas like apartments and balconies, eliminating the need for soil and maximizing space usage.

Testing of the system demonstrated its effectiveness in monitoring plant growth parameters, such as humidity, temperature, light levels, and nutrients. This system is

particularly beneficial for urban dwellers who prioritize fresh produce and sustainable living, as it provides a solution for growing vegetables with minimal human intervention. The paper concludes that such automated hydroponic systems promote sustainability, self-sufficiency, and efficient food production in urban environments, especially for individuals interested in small-scale farming [36].

II. Artificial Intelligence and Computer Vision

AI and computer vision technologies enable real-time analysis of plant health, nutrient deficiencies, and environmental adjustments. These advancements significantly reduce manual labor and enhance system reliability.

Dhiraj K. Shelke¹, et al. explore the potential of hydroponics as a sustainable farming solution in urban areas, driven by the challenges posed by population growth and urbanization. The increasing migration from rural to urban areas has resulted in underserved rural regions and overpopulation in cities. Hydroponics, a soil-free cultivation method, addresses these issues by allowing farming in vertical spaces, optimizing land use, and offering increased space efficiency. The automation of hydroponic systems further enhances productivity, enabling farmers to manage multiple tasks simultaneously.

This approach aims to provide an alternative food production method that can be scaled for both industrial and residential purposes.

The hydroponic system minimizes human intervention, leading to higher food yields compared to traditional farming. The produce is organic, pesticide-free, and more cost-effective than conventionally grown crops. The system also offers valuable insights into the growth process and the suitability of various crops for different conditions. Hydroponics has its roots in ancient agricultural practices and offers significant advantages: it is climate-resilient, space-efficient, requires fewer pesticides, ensures optimal nutrient delivery, and allows for experimentation with different crops.

For successful hydroponic farming, essential factors such as nutrient solution composition, oxygenation, pH levels, and light availability must be carefully managed. The system relies on specific nutrients like nitrogen, phosphorus, and potassium, which are dissolved in water to nourish the plants. In addition, light plays a critical role in photosynthesis, and artificial lighting is often used to supplement natural sunlight. With the increasing challenges of soil-based farming, particularly in rapidly urbanizing countries like India, hydroponics provides a viable solution for ensuring food security. However, widespread adoption depends on support from government initiatives and research institutions to advance the technology and promote its implementation[38].

Blacio et al, present a study on the use of the Internet of Things (IoT) as shown in Figure 5 to improve agricultural practices, specifically focusing on hydroponic systems. With the challenges of climate change and population growth, precision farming is becoming crucial for ensuring efficient food production. The study introduces an IoT-based monitoring system that uses Sigfox technology for scalable farm management, achieving an 89.37% prediction accuracy through neural networks. The proposed system is built on a four-layer architecture, consisting of perception, network, middleware, and application layers, which effectively monitors and controls critical parameters such as temperature, humidity, and nutrient levels in a hydroponic environment.

Conducted over a five-month period in Loja, Ecuador, the experimental validation shows the system's ability to dynamically adjust the hydroponic conditions based on input data, thereby enhancing agricultural efficiency. The system's flexibility and scalability were demonstrated in a hydroponic lettuce cultivation setup, ensuring continuous monitoring and optimal environmental control. Despite occasional packet loss and human errors, the system maintained an 85% availability rate and achieved full functionality in nutrient recirculation control.

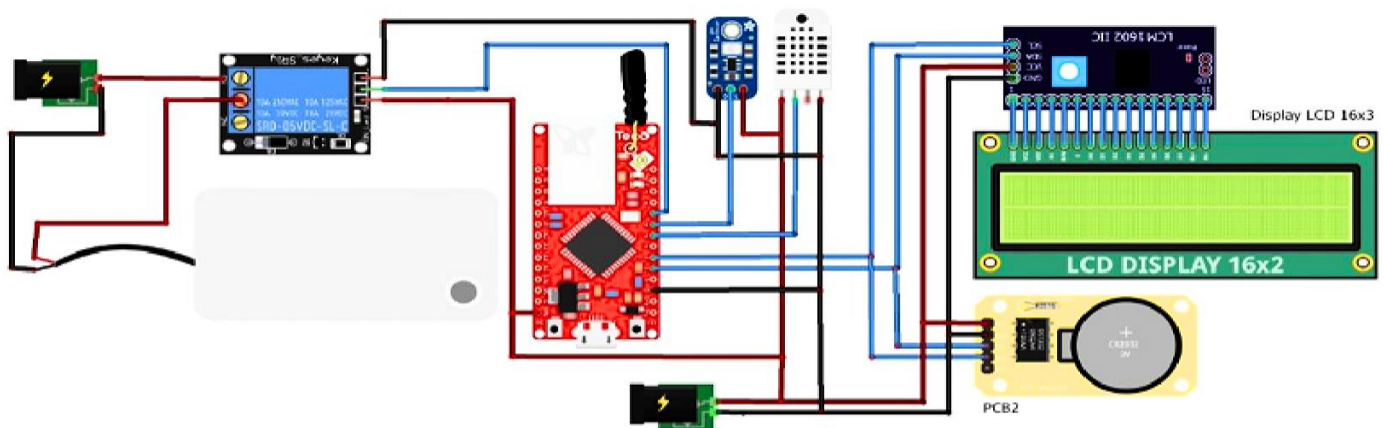

Figure 5: IoT device diagram [37].

Table 1: Comparative Analysis of Recent Contributions to Automated Hydroponics

Study	Focus Area	Innovations	Challenges/Findings	Future Directions
Al-Rukabi & Khalil[11]	Greenhouse designs	Vertical farming, cost-effective designs	High cost of implementation	Dynamic optimization of climate parameters
Chow Kheong Keat & Chithrameenal[13]	Vertical cylindrical hydroponics	LED lighting for optimized growth	Limited light efficiency at low intensity	Optimize light parameters
Dr. Ashok & Dr. Sujitha [18]	Greenhouse construction	Seasonal production enhancements	High labor and capital investment	Automation to reduce costs
Noureddine Choab et al.[14]	Moroccan greenhouse thermal performance	TRNSYS modeling, East-West orientation	High cooling demand in summer	Incorporation of renewable energy systems
Resham Chawl[15]	Evolution of soilless agriculture	Nutri-culture integration with renewables	Limited adoption in resource-poor regions	Expand research in low-cost technologies
Fabrizio Cumo et al. [16]	Multifunctional hydroponic greenhouses	Flexible urban structures	Low adoption in Italy	Awareness and economic incentives
Nikolov et al.[17]	IoT for indoor leafy vegetable farming	Small-scale affordable IoT solutions	Scalability for larger farms	Cost-benefit analysis for commercial scaling
Nahla Sadek et al.[21]	IoT and aeroponics for Egypt's agriculture	Smart greenhouse with automated control	Environmental variability control	Explore renewable energy integration
Usman Nurhasan et al.[22]	DFT hydroponics	Real-time monitoring with IoT	Dependence on high-quality sensors	Introduce redundancy in sensor systems
Pavan Koge et al.[23]	Urban hydroponics	IoT for space-efficient farming	High initial setup costs	Improve affordability for small farmers
Sowmya B. J. et al.[39]	IoT and computer vision	Real-time growth monitoring	Limited accuracy of plant health prediction	Enhanced AI models for plant diagnosis

Furthermore, the integration of machine learning algorithms enabled accurate temperature predictions, demonstrating the system's capacity for data-driven decision-making. The research highlights the effectiveness of IoT in smart agriculture, offering a cost-effective solution for optimizing conditions and improving productivity as shown in Figure 5. Future work will focus on further validating the system in greenhouse settings and refining temperature and humidity predictions for long-term sustainability in agriculture[37].

Sowmya B. J, et al. they developed and demonstrated an automated hydroponic farming system designed to address the growing challenges of food production in urban areas. By

integrating modern technologies such as Raspberry Pi, Arduino, and OpenCV, the system optimizes crop cultivation in a soilless environment, ensuring year-round fresh produce. The automation and use of IoT sensors enable precise monitoring and control of key factors such as water, nutrients, and environmental conditions, leading to improved crop yield and quality. This approach not only minimizes the use of chemicals, ensuring organic and pesticide-free produce, but also contributes to sustainable farming practices in urban settings. The system offers a scalable solution to the food security challenges posed by overpopulation and limited agricultural land, providing an innovative alternative to traditional farming methods. [39].

I. Contributions from Recent Studies

To understand the advancements and challenges in automated hydroponics, the contributions of various studies have been reviewed. The table below summarizes key aspects of these studies, offering a comparative perspective:

Conclusions

Automated hydroponic systems represent a significant advancement in agricultural technology, offering efficient and sustainable solutions to the challenges of food production. This paper has highlighted the effectiveness of various hydroponic methods and the integration of advanced technologies such as IoT, mobile applications, and computer vision. These innovations enable precise control over environmental factors, optimize resource utilization, and enhance crop yields, positioning hydroponics as a viable alternative to traditional farming.

However, several limitations persist in the implementation and scalability of automated hydroponic systems. High initial setup costs, technical complexity, and the need for continuous maintenance can deter widespread adoption, particularly among small-scale farmers. Additionally, challenges related to data security, interoperability of devices, and the accuracy of sensors can impact the reliability of these systems.

Future research should focus on addressing these limitations by exploring cost-effective solutions for smaller operations, enhancing sensor technology for improved accuracy, and developing user-friendly interfaces for easier system management. Additionally, studies could investigate the use of renewable energy sources to power hydroponic systems, further reducing their environmental impact.

Research should also aim to expand the range of crops suited for automated hydroponics, including more perishable and high-value plants. Exploring the socio-economic impacts of hydroponic farming in various regions, particularly in urban settings, could provide valuable insights into its role in food security. Finally, integrating advanced analytics and machine learning algorithms could optimize decision-making processes further, leading to improved outcomes in crop management and resource efficiency.

By addressing these aspects, future work can enhance the viability and adoption of automated hydroponic systems, contributing to a more sustainable agricultural landscape

References

- [1] R. Sharma, P. Barnwal, T. Das Vaishnav, S. Mishra, S. K. Ekka, and A. Kushwaha, "A Concept of Hydroponic System in Horticultural Crops," *Asian Journal of Biology*, vol. 20, no. 3, pp. 1–6, Feb. 2024, doi: 10.9734/ajob/2024/v20i3390.
- [2] "Hydroponic system: Basics of Hydroponics, Mineral Nutrition in Plants, Farming, Benefits, Application." Accessed: Dec. 20, 2024. [Online]. Available: <https://byjus.com/neet/hydroponic-system/>

- [3] D. Setiawan, Hamzah, L. Siswati, A. Ariyanto, and Guntoro, "Water pump control system in hydroponic plants using the ebb and flow method," in *IOP Conference Series: Earth and Environmental Science*, Institute of Physics, 2022. doi: 10.1088/1755-1315/1041/1/012020.
- [4] M. Hasnun et al., *Technological Advancement in Instrumentation & Human Engineer in Selected papers from ICMER 2021*, vol. 882. Springer, 2021. [Online]. Available: <https://link.springer.com/bookseries/7818>
- [5] A. Ani and P. Gopalakirishnan, "Automated Hydroponic Drip Irrigation Using Big Data," *Proceedings of the 2nd International Conference on Inventive Research in Computing Applications, ICIRCA 2020*, pp. 370–375, Jul. 2020, doi: 10.1109/ICIRCA48905.2020.9182908.
- [6] D. Prianka, G. V. Shilpa, H. Parvin, B. Prerana, and R. Gauda, "Wick-Based Hydroponics System with Mobile Application," *2024 IEEE International Conference on Information Technology, Electronics and Intelligent Communication Systems, ICITEICS 2024*, 2024, doi: 10.1109/ICITEICS61368.2024.10625158.
- [7] C. Maucieri, C. Nicoletto, R. Junge, Z. Schmutz, P. Sambo, and M. Borin, "Hydroponic systems and water management in aquaponics: A review," *Italian Journal of Agronomy*, vol. 13, no. 1, pp. 1–11, Mar. 2018, doi: 10.4081/IJA.2017.1012.
- [8] D. Vega et al., "Analysis of Deep Water Culture (DWC) hydroponic nutrient solution level control systems," *IOP Conf Ser Mater Sci Eng*, vol. 1108, no. 1, p. 012032, Mar. 2021, doi: 10.1088/1757-899X/1108/1/012032.
- [9] Ms. S. S. Rajendra and Mrs. S. A. Shrinivas, "Hydroponics Farming Using IoT," *Int J Res Appl Sci Eng Technol*, vol. 10, no. 4, pp. 584–588, Apr. 2022, doi: 10.22214/ijraset.2022.41311.
- [10] R. K. Sahdev, M. Kumar, and A. K. Dhingra, "A comprehensive review of greenhouse shapes and its applications," Sep. 01, 2019, *Higher Education Press Limited Company*. doi: 10.1007/s11708-017-0464-8.
- [11] M. Al-Rukabi and N. H. Khalil, "GREENHOUSE DESIGNS USED IN HYDROPONIC," All-Russian Conference of Young Researchers, Nov. 2022, pp. 136–140. [Online]. Available: <https://www.researchgate.net/publication/371636257>
- [12] S. H. van Delden et al., "Current status and future challenges in implementing and upscaling vertical

- farming systems,” Dec. 01, 2021, *Springer Nature*. doi: 10.1038/s43016-021-00402-w.
- [13] C. Kheong Keat and C. Kannan, “Development of a Cylindrical Hydroponics System for Vertical Farming,” *J Agric Sci Technol B*, vol. 5, pp. 93–100, 2015, doi: 10.17265/2161-6264/2015.02.003.
- [14] N. Choab, A. Allouhi, A. El Maakoul, T. Kousksou, S. Saadeddine, and A. Jamil, “Effect of Greenhouse Design Parameters on the Heating and Cooling Requirement of Greenhouses in Moroccan Climatic Conditions,” *IEEE Access*, vol. 9, pp. 2986–3003, 2021, doi: 10.1109/ACCESS.2020.3047851.
- [15] R. Chawla, “Hydroponics: Growing the Future of Sustainable Farming Hydroponics: Growing the Future of Sustainable Farming Article ID: 44699,” 2023. [Online]. Available: <https://www.researchgate.net/publication/376083444>
- [16] F. Cumo, B. de L. Vollaro, E. Pennacchia, R. Roversi, and V. Sforzini, “Design solutions for instrumental hydroponic greenhouses for receptive purposes,” in *WIT Transactions on the Built Environment*, WITPress, 2018, pp. 257–268. doi: 10.2495/UG180241.
- [17] N. V. Nikolov, A. Z. Atanasov, B. I. Evstatiev, V. N. Vladut, and S. S. Biris, “Design of a Small-Scale Hydroponic System for Indoor Farming of Leafy Vegetables,” *Agriculture (Switzerland)*, vol. 13, no. 6, Jun. 2023, doi: 10.3390/agriculture13061191.
- [18] Dr. A. Ashok and Dr. E. Sujitha, “Greenhouse structures, construction and design,” *Int J Chem Stud*, vol. 9, no. 1, pp. 40–45, Jan. 2021, doi: 10.22271/chemi.2021.v9.i1a.11417.
- [19] A. M. Hanafi, M. A. Moawed, and O. E. Abdullatif, “Evaluating Energy Efficiency and Thermal Performance in Egypt’s Social Housing: Climate Responsive Design and Material Impact in Hot Desert Environments,” *Journal of Engineering Research*, vol. 8, no. 6, pp. 1–14, Dec. 2024, Accessed: Jan. 11, 2025. [Online]. Available: <https://digitalcommons.aaru.edu.jo/erjeng/vol8/iss6/1>
- [20] A. Hanafi, M. Moawed, and O. Abdellatif, “Advancing Sustainable Energy Management: A Comprehensive Review of Artificial Intelligence Techniques in Building,” *Engineering Research Journal (Shoubra)*, vol. 53, no. 2, pp. 26–46, Apr. 2024, doi: 10.21608/erjsh.2023.226854.1196.
- [21] N. Sadek, N. kamal, and D. Shehata, “Internet of Things based smart automated indoor hydroponics and aeroponics greenhouse in Egypt,” *Ain Shams Engineering Journal*, vol. 15, no. 2, Feb. 2024, doi: 10.1016/j.asej.2023.102341.
- [22] U. Nurhasan, A. Prasetyo, G. Lazuardi, E. Rohadi, and H. Pradibta, “Implementation IoT in System Monitoring Hydroponic Plant Water Circulation and Control,” *International Journal of Engineering & Technology*, vol. 7, no. 4.44, p. 122, Dec. 2018, doi: 10.14419/ijet.v7i4.44.26965.
- [23] P. M. Koge*, N. B., K. T., and P. S., “Development and Monitoring of Hydroponics using IoT,” *International Journal of Recent Technology and Engineering (IJRTE)*, vol. 8, no. 6, pp. 4876–4879, Mar. 2020, doi: 10.35940/ijrte.F8710.038620.
- [24] A. Dudwadkar, T. Das, S. Suryawanshi, R. Dolas, T. Kothawade, and U. Student, “Automated Hydroponics with Remote Monitoring and Control Using IoT.” [Online]. Available: www.ijert.org
- [25] Prathima v. R, Vandhana Shree G S, Lavanya R, and Mounika J, “SMART HYDROPONIC FRAMING SYSTEM USING IOT,” *International Research Journal of Engineering and Technology*, vol. 7, no. 7, pp. 4810–4812, Jul. 2020, [Online]. Available: www.irjet.net
- [26] S. V. S. Ramakrishnam Raju, B. Dappuri, P. Ravi Kiran Varma, M. Yachamaneni, D. M. G. Verghese, and M. K. Mishra, “Design and Implementation of Smart Hydroponics Farming Using IoT-Based AI Controller with Mobile Application System,” *J Nanomater*, vol. 2022, 2022, doi: 10.1155/2022/4435591.
- [27] F. H. Azimi et al., “IOT monitoring in NFT hydroponic system using blynk-an android platform,” 2020.
- [28] P. Sihombing, N. A. Karina, J. T. Tarigan, and M. I. Syarif, “Automated hydroponics nutrition plants systems using arduino uno microcontroller based on android,” in *Journal of Physics: Conference Series*, Institute of Physics Publishing, Mar. 2018. doi: 10.1088/1742-6596/978/1/012014.
- [29] A. Pache, A. Dudhe, and B. Dharaskar, “Automated Hydroponics Systems, A Review and Improvement,” *International Journal of Science and Research (IJSR)*, vol. 11, no. 5, pp. 19–25, May 2022, doi: 10.21275/SR22429121630.
- [30] K. Kumari, A. Rai, A. Awasthi, and R. Baranwal, “Design an Implementation of Hydroponics Green House Farming using IoT,” 2023. [Online]. Available: www.ijres.org
- [31] R. Lakshmanan, M. Djama, S. K. Selvaperumal, and R. Abdulla, “Automated smart hydroponics system using internet of things,” *International*

- Journal of Electrical and Computer Engineering*, vol. 10, no. 6, pp. 6389–6398, Dec. 2020, doi: 10.11591/IJECE.V10I6.PP6389-6398.
- [32] S. Murali, S. T. Bharadwaj, and P. Janarthanan, “AUTOMATED HYDROPONIC PLANT GROWTH SYSTEM USING IOT,” 1406. [Online]. Available: www.irjmets.com
- [33] Iswanto, M. S. Masnawan, N. M. Raharja, and A. Ma’Arif, “Infusion Liquid Level Detection Tool Using IR Sensors and Photodiode Based on Microcontroller,” in *Proceeding - 2020 2nd International Conference on Industrial Electrical and Electronics, ICIEE 2020*, Institute of Electrical and Electronics Engineers Inc., Oct. 2020, pp. 70–73. doi: 10.1109/ICIEE49813.2020.9277363.
- [34] X. Zhang, D. He, G. Niu, Z. Yan, and J. Song, “Effects of environment lighting on the growth, photosynthesis, and quality of hydroponic lettuce in a plant factory,” *International Journal of Agricultural and Biological Engineering*, vol. 11, no. 2, pp. 33–40, 2018, doi: 10.25165/j.ijabe.20181102.3420.
- [35] V. Palande, A. Zaheer, and K. George, “Fully Automated Hydroponic System for Indoor Plant Growth,” in *Procedia Computer Science*, Elsevier B.V., 2018, pp. 482–488. doi: 10.1016/j.procs.2018.03.028.
- [36] S. Seni and L. Audah, “Automated Vertical Hydroponic Farming,” *Evolution in Electrical and Electronic Engineering*, vol. 1, no. 1, pp. 219–225, 2020, doi: 10.30880/eeee.2020.01.01.026.
- [37] M. Montaña-Blacio, J. González-Escarabay, Ó. Jiménez-Sarango, L. Mingo-Morocho, and C. Carrión-Aguirre, “Design and deployment of an IoT-based monitoring system for hydroponic crops,” *Ingenius*, vol. 2023, no. 30, pp. 9–18, Jul. 2023, doi: 10.17163/ings.n30.2023.01.
- [38] D. K. Shelke, P. N. Gavali, K. P. Naphade, and D. Falak, “IOT BASED HYDROPONIC SYSTEM,” *International Research Journal of Engineering and Technology*, 2022, [Online]. Available: www.irjet.net
- [39] B. J. Sowmya et al., “Computer Vision and IoT-Based Automated Hydroponic Farms in Urban Areas: A Soilless Cultivation,” <https://services.igi-global.com/resolvedoi/resolve.aspx?doi=10.4018/IJSESD.295966>, vol. 13, no. 1, pp. 1–21, Jan. 2022, doi: 10.4018/IJSESD.295966.