



Mathematical Modeling to Predict the Geometrical Properties of Float Stitches in Single Jersey Knitted Fabrics

نموذج رياضي للتنبؤ بالخصائص الهندسية للغرزة العائمة في أقمشة التريكو السادة

A. Fouda and M. Eldeeb

KEYWORDS:

Mathematical model, geometrical properties, AutoLISP, AutoCAD software, float stitches and knitted fabrics.

الملخص العربي:- يقدم هذا البحث نموذجاً رياضياً للغرزة العائمة بأقمشة التريكو السادة. تم استخدام النموذج الرياضي لاستنتاج العلاقات الهندسية النسيجية التي يمكن أن تكون مفيدة للتنبؤ بخصائص أقمشة التريكو. باستخدام برنامج AutoLISP و AutoCAD ، تم تصميم برنامج لمحاكاة المظهر السطحي لأقمشة التريكو. كما يتم عرض مدخلات ومخرجات البرنامج مع كل نوع من الغرزة العائمة. وأثبت كل من البرنامج والنموذج المقترح فاعليتهما في استخدام مدى واسع من نمر الخيوط، كثافة كل من الصفوف والاعمدة، والتنبؤ بالخصائص الهندسية المختلفة.

Abstract— This paper presents a novel mathematical model of float stitches in single Jersey knitted fabrics. The mathematical model has been used to deduce the fabric geometrical relationships that can be useful for predicting the properties of the fabric. Using AutoLISP and AutoCAD software, a program has been designed to simulate the surface appearance of knitted fabrics. The program inputs and outputs are also displayed with each type of float stitches. The proposed program and mathematical model demonstrated their effectiveness in using a wide range of yarn count, number of wales and courses, and predicting the different geometrical properties.

I. INTRODUCTION

It is known that knitted fabrics are comfortable and highly productive, compared to woven fabrics. However, their dimensional stability and lack of diversity in fabric appearance are their main problems. Nevertheless, various stitches, whether float or tuck stitches, were developed to improve the appearance of knitted fabrics.

Generally, research studies depend on mathematical models to predict the fabric properties that contribute to saving the required production time and efforts exerted while testing the fabric samples.

One of the studies predicted the knitted fabric weight per unit area using proKNIT software [1]. Nevertheless, the prediction of the fabric weight was dependent on calculated non-dimensional parameters. However, these parameters are limited to be used for wool knitted fabrics only. Another study [2] proposed a method that calculates a new evenness of mass index and denominated deviation rate and use it to classify of the knitted fabric quality. However, the study did not verify the results practically.

As far as the elastic properties of plain weft-knitted fabric composite are concerned, analytical and experimental procedures for estimating these properties were presented [3], the elastic moduli of the cotton yarn and knitted fabrics, having a different load span and knitting directions, based on the Leaf and Glaskin model were obtained. Furthermore, a numerical

Received: (11 February, 2020) - Accepted: (7 June, 2020)

A. Fouda, Textile Engineering Department, Faculty of Engineering, Mansoura University, Egypt

M. Eldeeb, Textile Engineering Department, Faculty of Engineering, Mansoura University, Egypt

(Finite Element Method) elastic properties averaging model was elaborated.

Similarly, the feasibility of assessing yarns with the Wool Comfort Meter (WCM) to predict the comfort properties of the corresponding single Jersey-knitted fabrics was examined [4]. The inclusion of knitting gauge and cover factor slightly improved predictions. This indicates that evaluation at the yarn stage would be a reliable predictor of knitted fabric comfort, and thus yarn testing would avoid the time and expense of fabric construction.

Another study demonstrated the applicability of the finite element method to analyze the bagging behavior of plain single Jersey weft knitted fabrics in terms of bagging resistance [5]. The study used solid elements and yarn transverse Isotropic properties and found a good agreement with experimental values. Nevertheless, that study is rarely used in the field of knitted fabrics.

Another study [6] created a three-dimensional plain of a warp pile woven fabrics structure fabric geometrical model. The model was based on the geometry of the unit cell of a single loop and was evaluated by using geometrical and mechanical porosity and measuring the air permeability value.

Furthermore, a novel mathematical model to predict the geometrical properties of bleached cotton plain single Jersey knitted fabrics was presented [7] and practical verification was carried out at different cotton yarn counts, twist factors, and loop lengths. The results showed a good agreement between the proposed mathematical and practical model. However, this model considered the geometry of the knitting loop as a semi-circle and straight lines, rather than circles and tangential lines.

Obviously, much of the researches based on mathematical models are concerned only with basic structures and traditional stitches (knit stitch). Therefore, this paper is mainly focused on one of the special knit stitches namely float stitch. Meanwhile focusing on developing a theoretical model based on different geometry of the knitting loop seeking more accuracy. Moreover, creating a simple and reliable program that simulates the appearance of knitted fabrics produced from float stitch regardless of the raw material.

II. MATHEMATICAL MODELS FOR KNIT AND FLOAT STITCHES

In this section, the mathematical model of the plain single Jersey knitted fabric and float stitches are deduced. The model of float stitches is presented through two stages namely float on a one-course model and float on a two-course model. In this model, the general assumptions are:

- 1- Yarns have a circular cross-section and can come into contact but it cannot be compressed.
- 2- Loops are formed from straight lines, which are tangents to circles.
- 3- The wales space at the maximum set is equal to four times the yarn diameter.

According to these assumptions, the knitted fabric appearance has been depicted as shown in Figure (1).

A. Mathematical model of single Jersey knitted fabrics

To find out the mathematical equations that represent the plain single Jersey knitted fabric, full repeat has been taken into consideration and its boundaries are UXYZ as shown in Figure (1). The dimensions of the half repeat for the studied loop are illustrated in Figure (2).

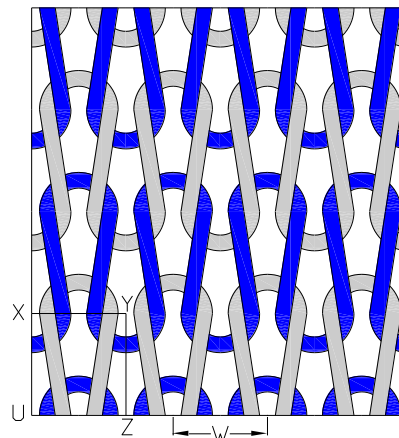

Fig. 1: The simulated appearance of single Jersey knitted fabric

As shown in Figure (2), the loop head and the stem can be drawn graphically by assuming an appropriate value for their radius of curvature (R). To avoid jamming, the radius of curvature should satisfy the following condition:

$$R < \left(\frac{w}{2} - \frac{d}{2} \right)$$

Where; w is the wales space (mm) and d is the yarn diameter (mm). According to the assumptions, the circles can be graphically drawn, by the radius R and yarn diameter. The stems can be drawn by a tangent to these circles. According to Figure (2), the following relationships can be deduced; the value of R as a function of the wale space and yarn diameter can be determined as follows:

$$\frac{w}{2} - R + d = R$$

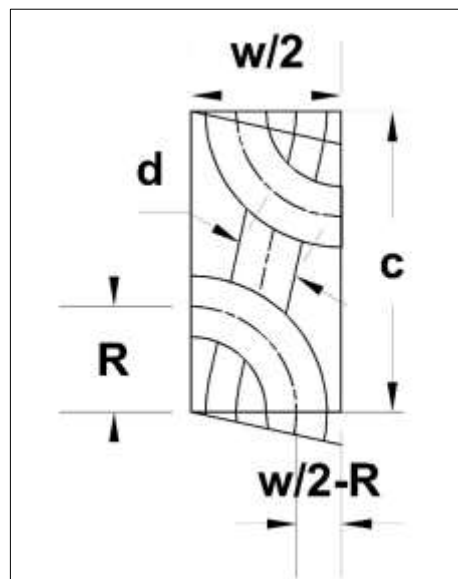

Fig. 2: Graphical representation of plain single Jersey general model

$$\text{Hence, } R = \frac{w}{4} + \frac{d}{2} \quad (1)$$

Since,

$$d = \frac{25.4}{28 \times \sqrt{N_e}} \quad (2)$$

Where, N_e is the English yarn count. The wale space w and course space c (mm), can be calculated according to equations (3) and (4) respectively.

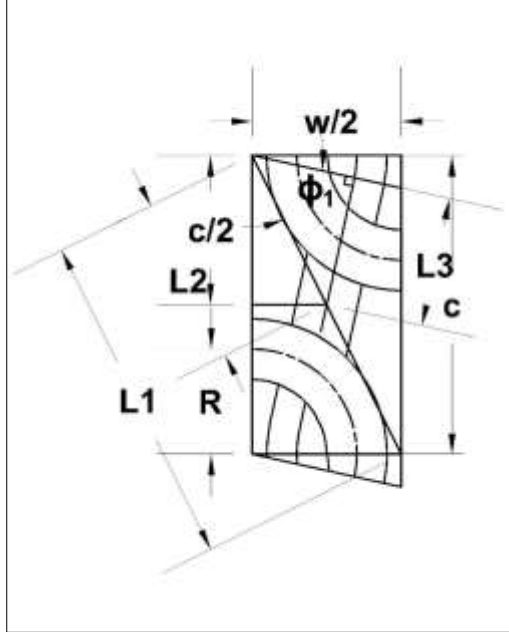

Fig. 3: Graphical representation of loop length for plain single Jersey model.

$$w = \frac{10}{W} \quad (3)$$

$$c = \frac{10}{C} \quad (4)$$

Where W and C are the wales and courses per cm respectively. The studied loop length in mm has been illustrated in Figure (3) and derived as follows,

$$L_1 = \sqrt{c^2 + \left(\frac{w}{2}\right)^2}$$

$$L_2 = \frac{L_1}{2}$$

$$\cos \phi_1 = R/L_2$$

$$L_3 = L_2 \cdot \sin \phi_1$$

Consequently,

$$\text{Loop length } (L_4) = 2\pi R + 4L_3 \quad (5)$$

From Figure 1, fabric cover factor $C.F$ and fabric porosity can be estimated according to equations (6) and (7) respectively.

$$C.F = \left[\frac{d \times \text{Loop length} - 4d^2}{c \times w} \right] \times 100 \quad (6)$$

$$\text{Porosity} = 100 - C.F \quad (7)$$

The fabric thickness is calculated by equation (8), which was estimated earlier as three times yarn diameter [6].

$$\text{Fabric thickness (mm)} = 3d \quad (8)$$

Evidently, the weight of the thread used to make one loop (W/loop) in (gm) and the weight of fabric square meter ($F.W$) in g/m^2 can be deduced according to equation (9) and

(10) respectively.

$$(W/\text{loop}) = \frac{\text{Loop length}}{N_m \times 1000} \quad (9)$$

$$F.W = \frac{(W/\text{loop}) \times 10^6}{c \times w} \quad (10)$$

B. Mathematical model of Float stitches on one course:

According to Figure (4), the average loop lengths for float stitches on one course and different knit wales can be deduced and have been demonstrated in equations (11), (12) and (13). The geometrical parameters of float stitch are described as float $x: y: z$, where x is no. of wales with the knit stitch, y is no. of wales with the float stitch, and z is no. of courses with the float stitch.

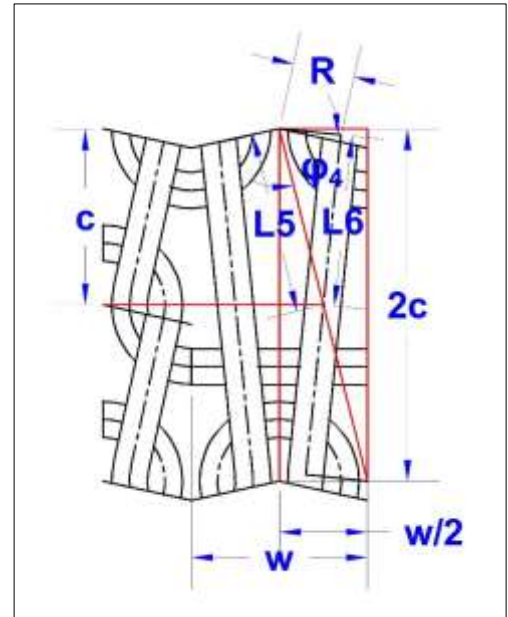

Fig. 4: Graphical representation of float stitch on one course

From Figure (4),

$$L_5 = \frac{\sqrt{(2c)^2 + \left(\frac{w}{2}\right)^2}}{2}$$

$$\cos \phi_4 = R/L_5$$

$$L_6 = L_5 \cdot \sin \phi_4$$

Thus,

$$\text{Float loop length } (L_7) = 2\pi R + 4L_6$$

Hence, for float 1:1:2 structure,

$$\text{average loop length } (L_8) = \frac{(6 \times L_4) + L_7 + w}{7} \quad (11)$$

For float 1:2:2 structure,

$$\text{average loop length } (L_8) = \frac{(8 \times L_4) + (2 \times L_7) + (2 \times w)}{10} \quad (12)$$

For float 2:2:2 structure,

$$\text{average loop length } (L_8) = \frac{(12 \times L_4) + (2 \times L_7) + (2 \times w)}{14} \quad (13)$$

C. Mathematical model of Float stitches on two courses

According to Figure (5), the average loop lengths for float stitches on two courses and different knit wales can be deduced and have been demonstrated in equations (14), (15), (16), (17) and (18).

$$L_9 = \frac{\sqrt{(3c)^2 + \left(\frac{w}{2}\right)^2}}{2}$$

$$\cos \phi_5 = R/L_9$$

$$L_{10} = L_9 \sin \phi_5$$

Thus,

$$\text{Float loop length } (L_{11}) = 2\pi R + 4L_{10}$$

Therefore,

For float 1:1:3 structure,

$$\text{average loop length } (L_{12}) = \frac{(5 \times L_4) + L_{11} + (2 \times w)}{6} \quad (14)$$

For float 1:2:3 structure,

$$\text{average loop length } (L_{12}) = \frac{(6 \times L_4) + (2 \times L_{11}) + (4 \times w)}{8} \quad (15)$$

For float 2:2:3 structure,

$$\text{average loop length } (L_{12}) = \frac{(10 \times L_4) + (2 \times L_{11}) + (4 \times w)}{12} \quad (16)$$

For float 2:3:3 structure,

$$\text{average loop length } (L_{12}) = \frac{(11 \times L_4) + (3 \times L_{11}) + (6 \times w)}{14} \quad (17)$$

For float 3:3:3 structure,

$$\text{average loop length } (L_{12}) = \frac{(15 \times L_4) + (3 \times L_{11}) + (6 \times w)}{18} \quad (18)$$

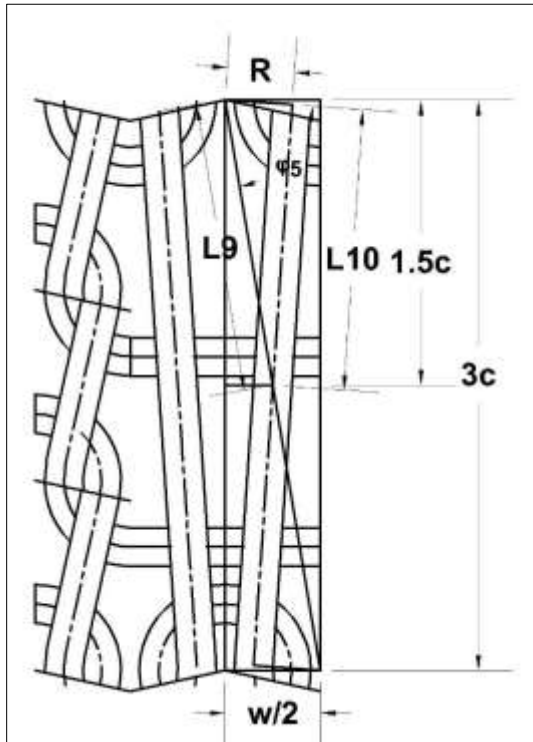

Fig. 5: Graphical representation of float stitch on two courses

III. METHODOLOGY

To verify the above-mentioned mathematical model, which assumes that the knitting loop consists of circles and tangents, plain single Jersey knitted fabric was produced using ALBI circular single Jersey knitting machine, Gauge 28, Diameter 17

inch and Number of feeders 34, with yarn count 32 Ne and loop length 2.8 mm. The loop length of the fabric sample was measured. 40*40 cm fabric samples were weighed five times using a digital balance of two decimal digits accuracy and the average weight was recorded. The fabric thickness was measured according to ASTM D1777 – 96 (2019). By using AutoLISP programming language along with AutoCAD software, a program was created to draw plain and float knitting stitches in their various forms and to calculate loop length and fabric weight, cover factor, porosity, and thickness. The program code inputs are the number of wales per cm, number of courses per cm, yarn count and the corresponding mathematical equations for each type of stitches. Moreover, Table 1 shows part of the program code that was created.

TABLE (1)

PART OF AUTOLISP PROGRAM CODE

```
(cond ((> x 0)
(command "ucsicon" "off")
(setq l1 (sqrt (+(* b b) (*( / a 2) (/ a 2))))))
(setq p1 (list 65 150))
(setq p2 (list (car p1) +(cadr p1) r1)))
(command "circle" p10 p12)
(command "regen")
(command "line" "tan" p11 "tan" p23 ""))
(command "copy" "last" "" "m" p10 p1 p25 ""))
(command "erase" p11 p12 ""))
(command "line" p2 p3 ""))
(command "trim" p1 p29 "" p30 p31 ""))
(command "text" "j" "bl" w38 3 0 "Magnified - 4x")
(command "zoom" "e")
(command "layer" "off" 0 ""))
(princ)
```

IV. RESULTS AND DISCUSSIONS

By running the program that was created, the geometrical properties of single Jersey knitted fabrics were predicted as shown in Figure 6. The values of practical and predicted geometrical properties for single Jersey knitted fabrics are shown in Table 2. It is clear that there is a strong agreement between practical values of single Jersey knitted fabric geometrical properties and the results of the proposed theoretical model where the prediction error ranges from 0.3125% to -4.7%.

TABLE (2)

THE VALUES OF PRACTICAL AND PREDICTED GEOMETRICAL PROPERTIES

Properties	Practical	Predicted	Prediction error (%)
Loop length (mm)	2.8	2.668	-4.7
Fabric weight (g/m ²)	112	110.994	-0.9
Fabric Thickness (mm)	0.5	0.4815	-3.7

Consequently, the engineering properties of knitted fabrics with floating stitches can be predicted, as well as observing the appearance of these fabrics and identifying their shape before the production process. The following Figures (7 to 14) show the program outputs for each type of floating stitches, and the Figures demonstrated the program flexibility to use a variety of courses and wales as well as a variable range of yarn counts.

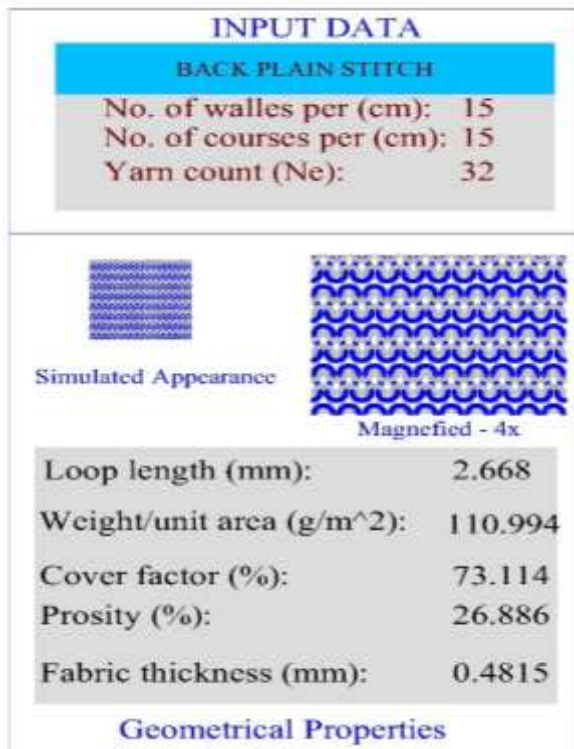

Fig. 6: Theoretical properties of single Jersey knitted fabrics (Program output)

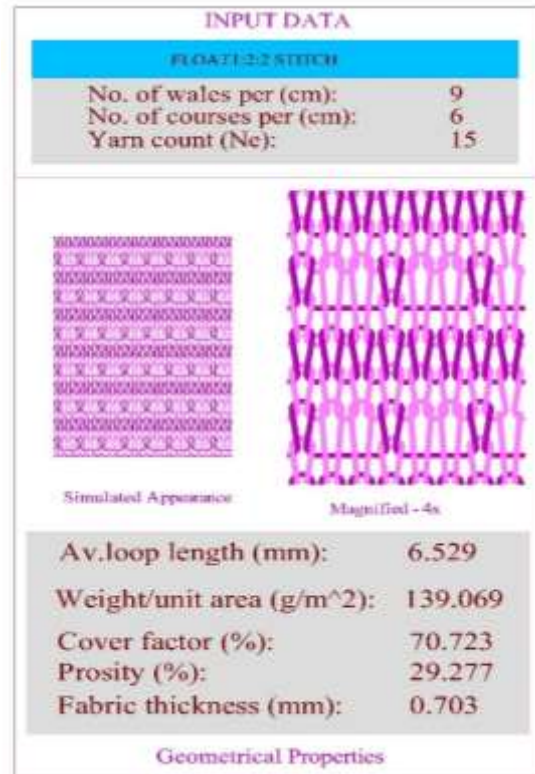

Fig. 8: Theoretical properties of float stitch 1:2:2

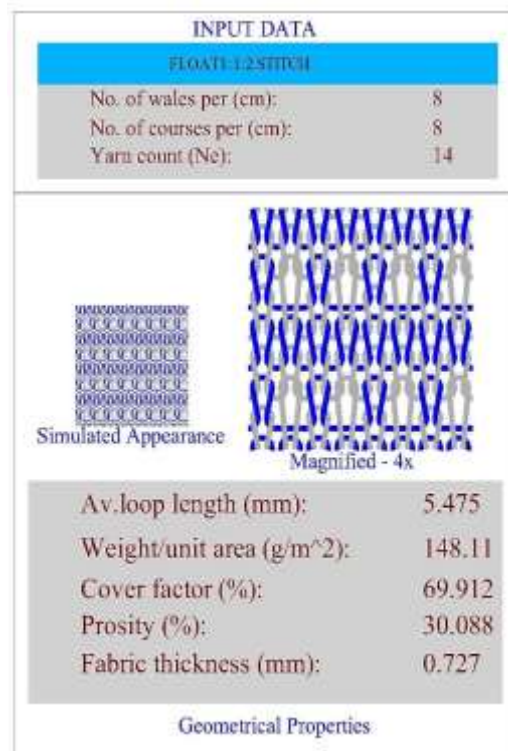

Fig. 7: Theoretical properties of float stitch 1:1:2

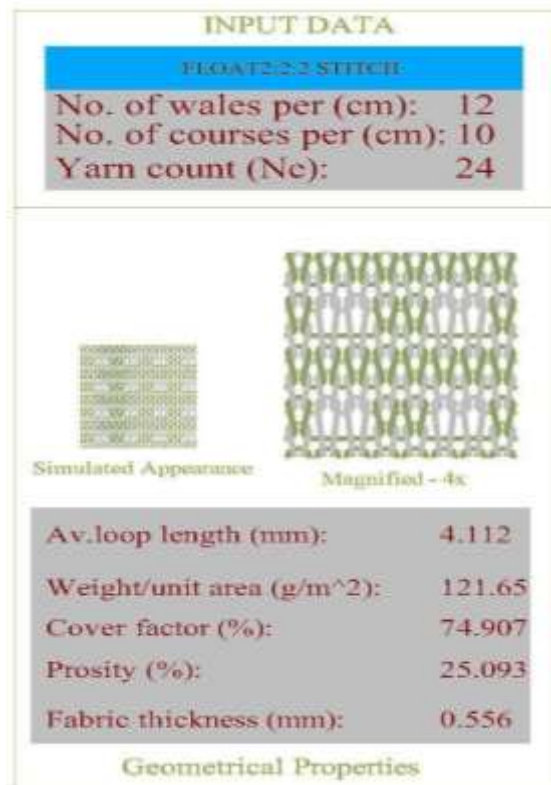

Fig. 9: Theoretical properties of float stitch 2:2:2

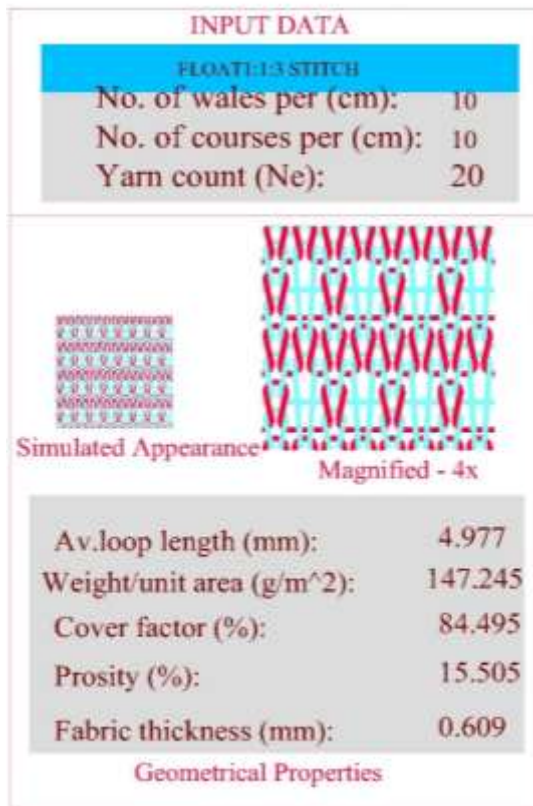

Fig. 10: Theoretical properties of float stitch 1:1:3

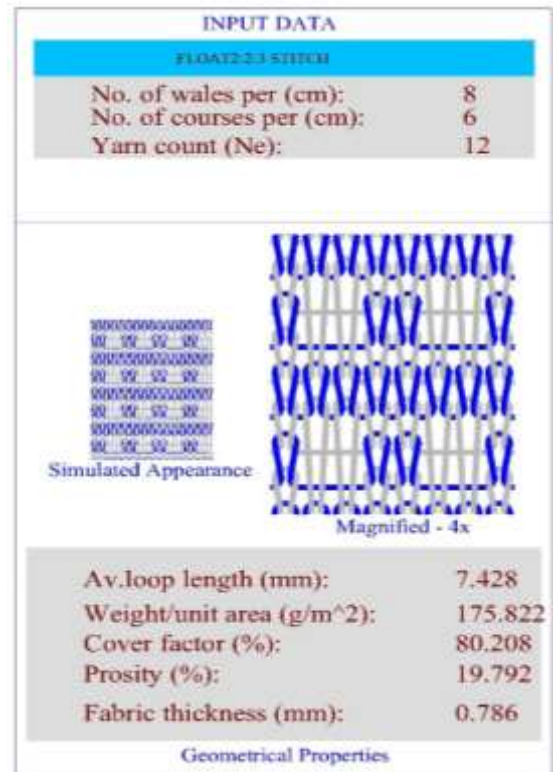

Fig. 12: Theoretical properties of float stitch 2:2:3

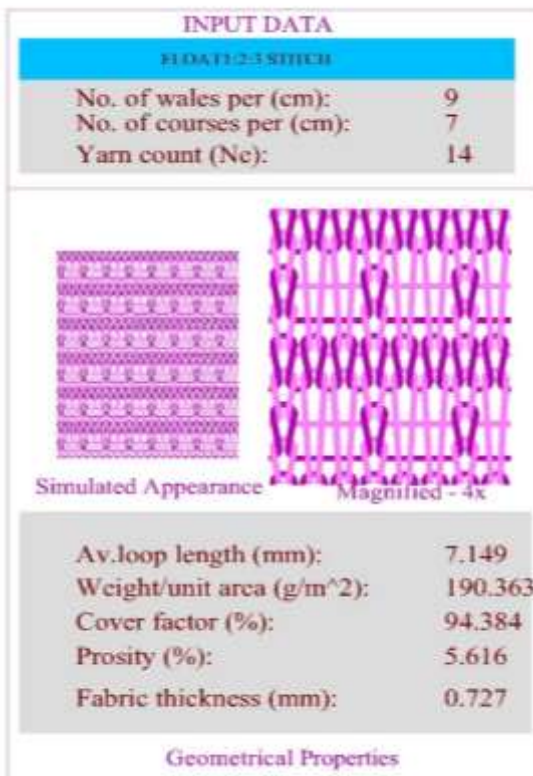

Fig. 11: Theoretical properties of float stitch 1:2:3

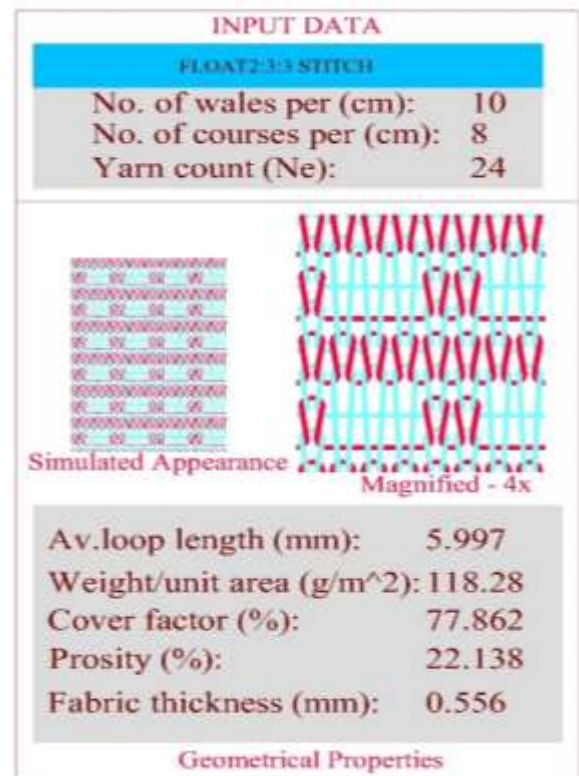

Fig. 13: Theoretical properties of float stitch 2:3:3

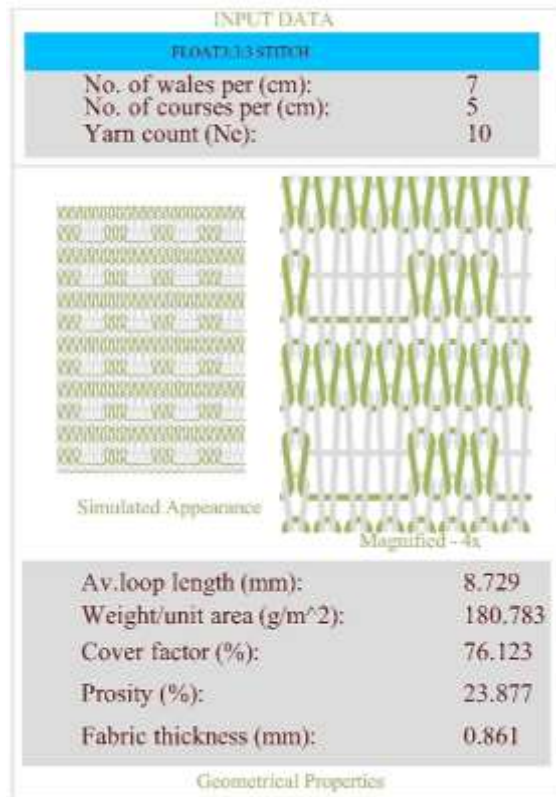

Fig. 14: Theoretical properties of float stitch 3:3

V. CONCLUSION

In this paper, a mathematical model for plain single Jersey knitted fabric (knit and float stitches) were presented. In addition, a program was created by the AutoLISP programming language and the AutoCAD software, which simulates the appearance of knitted fabrics. The results showed the ability of the proposed theoretical model and the software along with the programming to predict the geometrical properties of different float stitches. Consequently, the effort, material, and testing of fabric can be reduced while studying the geometrical properties of knitted fabrics.

VI. REFERENCES

- [1] T E. Gravas, P. Kiekens and L. van Langenhove, : "Predicting Fabric Weight Per Unit Area of Single and Double-Knitted Structures Using Appropriate Software", AUTEX Research Journal, Vol. 6, No. 4, pp. (223-237), 2006.
- [2] Feliu Marsal and Daniel Palet: "Aspect Prediction of the Knitted Fabrics from the Yarn Properties", INTERNATIONAL SCIENTIFIC CONFERENCE (Annals of The Oradea University), 2009.
- [3] Olga Kononova, et al., "Modeling and experimental verification of mechanical properties of cotton knitted fabric composites", Estonian Journal of Engineering, Vol. 17, No. 1, pp. (39–50), 2011.
- [4] M. Naebe, V. Lutz and X. Wang, : "Predicting comfort properties of knitted fabrics by assessing yarns with the Wool Comfort Meter", Journal of Textile Institute, Vol. 104, No. 6, pp. (628–633), 2013.
- [5] Mitra Karimian and Saeed Ajeli, : "Numerical modeling of bagging behavior of plain weft knitted fabric using finite element method", Indian Journal of Fibers and Textile Research, Vol. 39, pp. (204-208), 2014.
- [6] Elsayed A Elnashar: "Volume porosity and air permeability in knitting fabrics", International Journal of Research in Advanced Engineering and Technology, Volume 3; Issue 1; Page No. 75-80, January 2017.
- [7] A. Fouda, A. El-Hadidy, and A. El-Deeb, "Mathematical Modeling to Predict the Geometrical and Physical Properties of Bleached Cotton Plain Single Jersey Knitted Fabrics", Volume 2015, Article ID 847490, 10 pages, Journal of Textiles, Hindawi Publishing Corporation, (<http://dx.doi.org/10.1155/2015/847490>).
- [8] David j. Spencer, C Text, ATI, ACFI, "Knitting Technology a Comprehensive Handbook and Practical Guide", Third edition, WOODHEAD PUBLISHING LIMITED, England, 2003.