

BASIC REQUIREMENTS FOR THE DESIGN AND CONSTRUCTION OF A LOCAL COMPOST SCREENING UNIT

Mariam, M. M.*; A. F. Abdel Mottaleb;
A.A. Derbala***and T.Z. Fouda ******

ABSTRACT

Theoretical analysis was carried out to design and construct a local compost screening unit to achieve maximum cleaning efficiency.

Theoretical analysis was conducted to estimate optimum sieve speed, optimum screen opening size, optimum sieve inclination angle. Maximum required power was estimated in order to provide the machine with the suitable source of power. The machine shaft was designed so as to save it from over loads and the high stresses.

Theoretical analysis reveal that the local compost screening unit is preferred to be constructed under the following conditions:

- *The sieve revolutions number should be lower than 43 rpm.*
- *The screen opening size should be of about 13 mm.*
- *The slope angle of the cylindrical sieve on the horizontal plane (sieve inclination angle) should be lower than 27 degrees.*
- *The motor power required for screening compost must be not less than 3.68 kW (5.0 hp).*
- *The machine shaft must be designed at a 70 mm diameter.*

INTRODUCTION

Field crop residues are considered one of the most critical problems which face the Egyptian farmer. In Egypt, there are about 30 million tons yearly of the field raw material, the most important of which are rice straw (4 million tons), corn stalks (3.5 million tons) and cotton stalks (2 million tons) (according to the statistics of the control Authority for Agricultural Economy in 2008).

* Grad. St., Agric. Eng. Dept., Fac. Of Agric., Tanta Univ.

** Senior Res., Agri. Eng. Res. Inst. (A.R.C.), Egypt.

*** Assoc. Prof. Of Agric. Eng., Fac. Of Agric., Tanta Univ.

**** Prof. and Head Of Agric. Eng. Dept., Fac. Of Agric., Tanta Univ.

Accumulation of these residues in large quantities results not only in deterioration of the environment but also in a loss of potentially valuable material. Manuring with these residues through composting is a promising route, especially with the increase in fertilizer price.

The good composting structure depends on the correct mixing and turning of materials as well as, after maturity the correct screening of the produced compost.

Screening improves the quality of the produced compost for sale or use by removing unwanted objects such as rocks, metals, clumps, and other trash. Added to that screening removes residues which are not fully composted (un composted material) from the final product to be reused as an active material (a supply of microorganisms) for the new composting operation.

Robert (1992) stated that the common screens used to clean compost were as follows: Trommel screens which are a rotating drum with holes, the drum is inclined or contains internal flights to remove the materials through as it rotates. Shaker screens which create a reciprocating motion which bounces the material along the screen length. Vibrating screens which use an oscillating motion to enhance cleaning. Flexing belt screens which use a slotted belt of a durable material. Disc screens which use banks of overlapping, scallop-edged rotating discs to move coarse items from one end of the screen to the other. Auger and trough screens which consist of a perforated trough containing an auger that moves the materials from one end to the other. Rotary screens (Spinning disk) which have plates or discs with holes of selected size onto which a material is fed.

William (2000) stated that the acceptable quantities of foreign matter in compost have been a subject of some debate, but generally there is greater agreement on these standards. Normally, stones are distinguished from non-decomposable "foreign matter" which includes glass, plastic and metal. The limits pertain to a percentage at a specific screen size. He classified foreign matter in compost into two parts: Stones % of dry weight and Man-Made Foreign Matter (glass, plastic, metal), as% of dry weight.

Amin et al. (2002) developed and evaluated a simple cleaning and grading machine for cleaning spherical products. Their results showed that the machine is quite successful for cleaning at a sieve speed of 0.15 m/s and at slope angle of zero.

Page et al. (2005) determined whether passing compost through a ball screen, an 18.75 mm trommel screen, or twice through an 18.75 mm trommel screen lead to the lowest levels of foreign would matter (undesirable material remaining in the final product) in the municipal solid waste compost. They found that the overall percentage of foreign matter ranged from 1.8% for the ball screen, to 2.72% for one pass with a trommel screen, and 1.75% for two passes with the trommel screen. Therefore, processing with the ball screener or two passes with the trommel screener created compost with a lower percentage of foreign matter.

Suzanne et al (2005) when developing an industry standard for compost quality, the presence of foreign matter in compost should be taken into consideration since it has a negative impact on consumers and on the composting industry in general. The consumers look for compost free of visible foreign matter or otherwise harmful foreign matter. Foreign matter is defined in the BNQ standard as follows: "Any matter over a 2 mm dimension that results from human intervention and having organic or inorganic constituents such as metal, glass and synthetic polymers (e. g., plastic and rubber) that may be present in the compost but excluding mineral soils, woody material and rocks."

Compost screening in Egypt is still carried out manually, which is tedious and consumes long time with low productivity, or by many imported technologies which require high cost.

Therefore, such studies had to be carried out to solve the problem of compost screening under conditions of small Egyptian farmers. Local compost cleaning machine is the successful answer to clean compost. So, the objective of this study is to carry out theoretical analysis to design and construct a simple low cost machine from local material to be used for compost cleaning taking into consideration its effectiveness.

MATERIAL AND METHOD

Theoretical analysis was carried out to design and construct a local compost screening unit to achieve maximum cleaning efficiency.

1-Material

1.1.The local compost screening machine

A local screening machine, suitable for compost cleaning, was suggested to be manufactured from low cost, local material to overcome the problems of high power and high cost requirements under the use of the imported machines. The developed machine, which consists mainly of screening device and feeding device is shown in Fig 1.

- The screening device

The screening device separates the principle product (clean compost) from coarse impurities and un composted material. The screening device consists mainly of power source, transmission system, machine frame and cleaning unit.

- The feeding device

The feeding device is used to control the compost feeding rate passing to the cleaning unit. The feeding device consists mainly of four main parts power source, transmission system, feeding device frame and the rubber conveyor belt.

1.2. Instruments

- Stop watch with an accuracy of 0.02 second.
- Hand contact tachometer with an accuracy of 2 rpm.
- Repose angle meter
- Friction angle device with an accuracy of 0.01 degree.
- Electric digital balance with an accuracy of 0.01 g.
- Electronic digital vernier caliper with an accuracy of 0.01 mm.
- Electrical current meter with an accuracy of 0.1 A.

2- Methods

During the construction of the cleaning machine, it is important to design and adjust its parts to achieve maximum working efficiency.

- In order to construct the transmission system of the machine, it is of great importance to estimate optimum sieve speed that gives maximum cleaning efficiency.

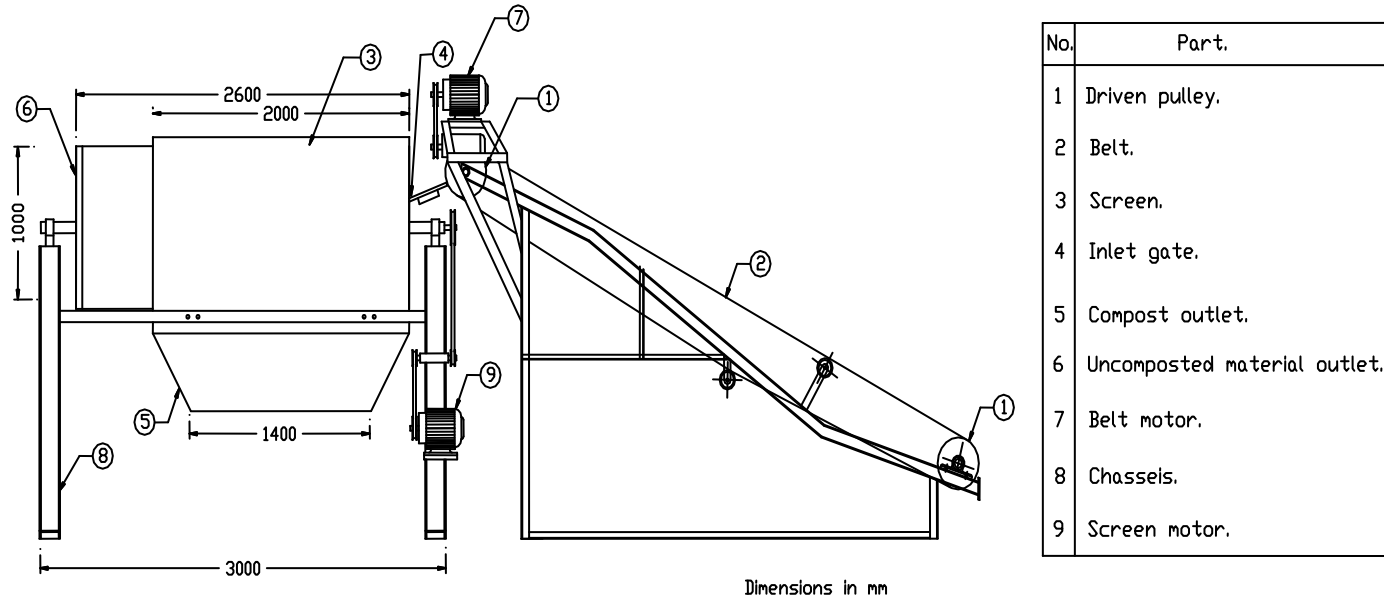

Fig. 4-1: The locally manufactured compost screening unit.

- It is important to determine optimum screen opening size to achieve maximum cleaning efficiency in respect to standard specifications of compost.
- It is important to estimate optimum sieve inclination angle so that the machine must have means of moving the sieve up and down.
- It is important to estimate the maximum required power in order to provide the machine with the suitable source of power.
- It is of great importance to design the machine shaft so as to save it from over loads and the high stresses.

2.1. Adjustment of Sieve speed

A cylindrical sieve is used to remove both impurities and uncomposted residues adhering to compost. The compost is delivered from one end of the rotating cylindrical sieve (inclined or horizontal). Then the compost tries to reach the other end of the cylinder.

The work of the cylindrical sieve involves the following operations: picking up small particles of the material by its cells, lifting the particles and throwing them into the receiver trough.

The compost mass in the cylindrical sieve is set in motion when the sieve begins to move. The particles next to the cells are carried in the direction of rotation of the cylinder because of friction at the cell surfaces (**Klenin et al. 1985**).

During this action, particles located at the lower portion of the cylinder are lifted upward by the screen surface to some height after which they are again lifted along with it and slide down. They gradually move toward the opposite end of the cylinder. The particles are in contact with only a part of the cylindrical surface and have no relative velocity with respect to it during their lift. For these reasons, sieving of small particles is possible only when they have some finite relative velocity in respect to cylinder speed.

The nature of the motion of compost over the surface of a cylindrical sieve depends upon the coefficient of friction on the given surface; the kinematics operation condition is governed by centripetal acceleration $\omega^2 r$, the initial conditions of motion of the particles, the point at which they are delivered on to the sieving surface and their initial velocity.

Depending upon the relationship among the above factors, the compost in the cylinder may slide along it, separate from its surface and perform a free flight or may move with the surface being at rest relative to it. In the last case the compost material is not sieved (**Bosoi et al. 1991**).

The release of compost (particles) in a cylindrical sieve depends upon their relative velocity and the forces acting on them. These forces are:

- The weight of the particle (**mg**), directed downward.
- The centrifugal force (**m ω²r**).

Where:

- m** - The mass of the particle
- r** - Radius of the cylinder
- ω** - Cylindrical sieve angular velocity (at critical speed, the angular velocity of the particle **ω_p = ω**).

The motion of the particle on the cylinder surface is not determined by the tangential forces alone. But, if the resultant of the normal forces (**F_n**) is not directed towards the cylinder surface, the particle will lose contact with the cylinder.

To find the equations that describe the motion of the particle at a critical speed of the cylindrical sieve (Fig. 2), it can be found that:

- In the normal direction:

$$F_n = m\omega^2r - mg \sin\alpha \dots\dots\dots (1)$$

- In the tangential direction:

$$mg \cos\alpha = \mu F_n \dots\dots\dots (2)$$

Where:

- α** - Angular position of particle on the sieve surface measured from the horizontal axis in the direction of rotation ;
- μ** - Coefficient of friction between the particle and cylindrical surface .

By substituting **F_n** from equation (1) into equation (2) then:

$$mg \cos\alpha = \mu (m\omega^2r - mg \sin\alpha) \dots\dots\dots(3)$$

$$g \cos\alpha = \mu \omega^2r - \mu g \sin\alpha$$

$$\mu \omega^2r = g \cos\alpha + \mu g \sin\alpha$$

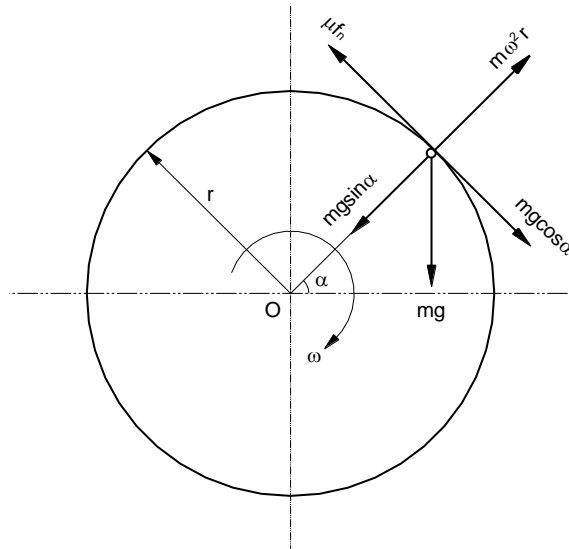

Fig.2: Forces acting on a particle of compost in a rotating cylinder

$$\omega^2 = \frac{g \cos \alpha + \mu g \sin \alpha}{\mu r} \dots\dots\dots(4)$$

$$\omega = \sqrt{\frac{g \cos \alpha + \mu g \sin \alpha}{\mu r}} \dots\dots\dots(5)$$

But

$$\omega = 2\pi N / 60 \dots\dots\dots(6)$$

So, from equations (5), (6):

$$N = \frac{60}{2\pi} \sqrt{\frac{g}{\mu r} (\cos \alpha + \mu \sin \alpha)} \dots\dots\dots(7)$$

2.2. Selection of proper screen opening

Robert (1992) stated that for screening compost, the screen openings should be 0.25 to 0.5 inch (0.63 to 1.27 cm), depending upon the material to be separated out and the end use for the compost. Smaller openings provide better separation but, for a given screen, reduce the

capacity and increase the chances of blinding. The screen effectiveness decreased when particles larger than desired pass through the screen or when particles of the desired size are retained by the screen. Both effectiveness and capacity are influenced by the screen opening size.

2.3. Adjustment of sieve inclination angle

The sieves are set inclined to the horizontal plane to improve the internal pressure forces during the rotation of the particles mass. According to **Klenin et al. (1985)**, the angle of sieve inclination (Θ) was selected from the condition:

$$\Theta \leq \Phi$$

Where:

Φ - The friction angle between the compost and the sieve surface.

2.4. Determination of motor power

The power required for screening compost (**P**) consists of the power required for sieving action (**P₁**) and the power required to overcome friction at the screen bearing (**P₂**) (**Klenin and Sakon , 1980**).

$$\mathbf{P} = \mathbf{P}_1 + \mathbf{P}_2$$

The power required for the sieving action (**P₁**) can be determined as follows:

$$\mathbf{P}_1 = 0.5 \mathbf{M} \mathbf{V}^2$$

Where :

$$\mathbf{M} = \mathbf{m}_1 + \mathbf{m}_2$$

m₁ - The feed rate of the compost mass, kg/s,

m₂ - The sieve mass, kg,

V - Sieve peripheral speed, m/s.

Sieve peripheral speed can be determined as follows:

$$\mathbf{V} = \boldsymbol{\omega} \mathbf{r}$$

Where :

r - Screen radius, m,

ω - Screen angular velocity, rad/s,

$$\boldsymbol{\omega} = 2\pi \mathbf{N}/60$$

N - Number of screen revolutions per minute, rpm.

The power required to overcome friction at the screen bearing (**P₂**) can be determined as follows:

$$P_2 = F V$$

$$F = \mu N$$

Where:

- μ - Coefficient of friction,
- N - Normal bearing reaction, N.

2.5. Design of sieve shaft

The sieve shaft is supported by two bearings. A belt of V- shape is fixed on the pulley in the end of the shaft to transport load (F_1). Another distributed load due to the shaft mass, sieve mass and compost mass (F_2) is applied to the same shaft. Both loads are in the same plane and direction (Fig. 3).

The shaft in this case is subjected to combine torsion and bending stresses. Shafts stressed in torsion and bending are calculated on the combined stress. The diameter of sieve shaft in this case can be calculated according to the maximum shear stress theory as follows (**Khurmi and Gupta, 1984**):

$$\tau_{\max} = \frac{1}{2} \sqrt{k_m^2 \sigma_b^2 + k_t^2 \tau_{tor}^2} \dots\dots\dots (8)$$

$$\tau_{\max} = \frac{1}{2} \sqrt{k_m^2 \left(\frac{32M}{\pi d^3} \right)^2 + 4k_t^2 \left(\frac{16T}{\pi d^3} \right)^2} \dots\dots\dots (9)$$

$$\tau_{\max} = \frac{16}{\pi d^3} \sqrt{k_m^2 M^2 + k_t^2 T^2} \dots\dots\dots (10)$$

Where :

- τ_{\max} - Maximum shear stress, $\tau_{\max} = 5000 \text{ N/cm}^2$,
- σ_b - Bending stress, N/cm^2 ,
- τ_{tor} - Torsion stress, N/cm^2 ,
- M - Maximum bending moment, N.cm,
- T - Maximum torque, N.cm,
- d - Diameter of shaft, cm,
- K_m - Shock factor for bending, $K_m = 2.0$,
- K_t - Shock factor for torsion, $K_t = 1.8$.

To determine both **M** (maximum bending moment) and **T** (maximum torque), the forces **F₁** and **F₂** (distributed load) acting on the shaft must be calculated.

- Determination of F₁

Force **F₁** represents tension forces on the pulley added to the pulley weight as follows:

$$F_1 = T_1 + T_2 + W$$

Where:

- T₁** - Maximum tension on the pulley,
- T₂** - Minimum tension on the pulley,
- W** - Pulley weight, **W = 50N**.

Maximum tension on pulley can be calculated according to the following equation (**Khurmi and Gupta, 1984**):

$$T_1 = T - T_c$$

$$T = \sigma_t \cdot A$$

$$T_c = m \cdot V^2/r$$

$$m = A L D$$

Where:

- σ_t** - Allowable tension stress (**280 N/cm²**),
- A** - Cross – sectional area of the belt, **cm²**,
- T_c** - Centrifugal tension force,
- V** - Belt speed,
- r** - Radius of turning.
- m** - Mass of the belt per meter length, **kg**,
- L** - Belt length, **cm**,
- D** - Density of belt material (**0.001 kg/cm³**).

Minimum tension on pulley can be calculated according to the following equation (**Khurmi and Gupta, 1984**):

$$2.3 \text{ Log } T_1/T_2 = \mu \Phi \text{ cosa}$$

Where:

- μ** - Coefficient of friction,
μ = 0.54 – 42.6 / (152.6 + V)
- 2α** - Groove angle of the pulley (30 – 40 deg),
Sina = (r₁ – r₂) / x

$$\Phi = (180 - 2\alpha) \cdot \pi/180$$

r_1 - Radius of drive pulley,

r_2 - Radius of driven pulley.

- Determination of F_2

Force F_2 represents distributed load due to the shaft mass, sieve mass and compost mass.

$$F_2 = W_1 + W_2 + W_3$$

Where:

W_1 - Weight of compost material, N,

W_2 - Weight of screen, N,

W_3 - Weight of shaft, N.

RESULTS AND DISCUSSION

The discussion will cover the obtained results under the following heads:

1-Estimation of sieve speed

Depending on equations from 1 to 7, which describe the work of the cylindrical sieve, sieve revolutions number can be estimated as follows:

At $\alpha = 90^\circ$; $r = 50$ cm.

$$N = \frac{60}{2\pi} \sqrt{\frac{g}{r}}$$

The previous equation shows the number of rotations per minute (critical sieve speed).

The critical speed of the sieve (N) was calculated by substituting the parameter {r (cylinder radius) = 50cm} in the previous equation.

The critical speed of the sieve was found to be:

$$N = 42.6 \sim 43 \text{ rpm}$$

Under this study, the number of revolutions of the sieve should be lower than 43 rpm. That is because the particle motion which facilitates the removal of impurities from the compost is due to the relative motion of the compost layers and the axial displacement of the particles.

2. Selection of proper screen opening

Referring to **Robert (1992)**, added to the results of the preliminary experiments, the screen opening size should be of about 13 mm in order to achieve optimum cleaning efficiency in respect to standard specifications of compost with reasonable screen capacity. Added to that screen blinding can be avoided.

3- Determination of sieve inclination angle

According to **Klenin et al. (1985)**, the slope angle of the cylindrical sieve on the horizontal plane (sieve inclination angle) should be lower than 27 degrees (to be less than the friction angle between the compost material and the sieve surface).

4. Estimation of motor power

According to **Klenin and Sakon (1980)**, let the power source, that should operate the screening unit develop and transmit power **P_p** to the sieve at a speed of N rpm.

The ratio of the power developed and the demand power **P** governs the operating conditions of the screen.

If **P_p > P**, then part of the power equal to **P_p - P**, goes toward increasing the screen speed.

If **P_p < P**, the screen speed falls.

So, under this study and by using the above equations, The motor power required for screening compost must be not less than **3.68 kW (5.0 hp)**.

5. Estimation of shaft diameter

According to **Khurmi and Gupta (1984)**, **T₁**, **T₂** and **F₁** were calculated and found to be with the following values:

$$T_2 = 350 \text{ N}$$

$$T_1 = 850 \text{ N}$$

$$F_1 = 850 + 350 + 50 = 1250 \text{ N}$$

According to the same previous analysis **F₂** was calculated as follows:

$$F_2 = 2000 + 1400 + 100 = 3500 \text{ N}$$

By using the loading diagram (Fig. 3), the reactions **R₁**, **R₂** can be calculated to be as follows:

$$R_1 = 1700 \text{ N}$$

$$R_2 = 2600 \text{ N}$$

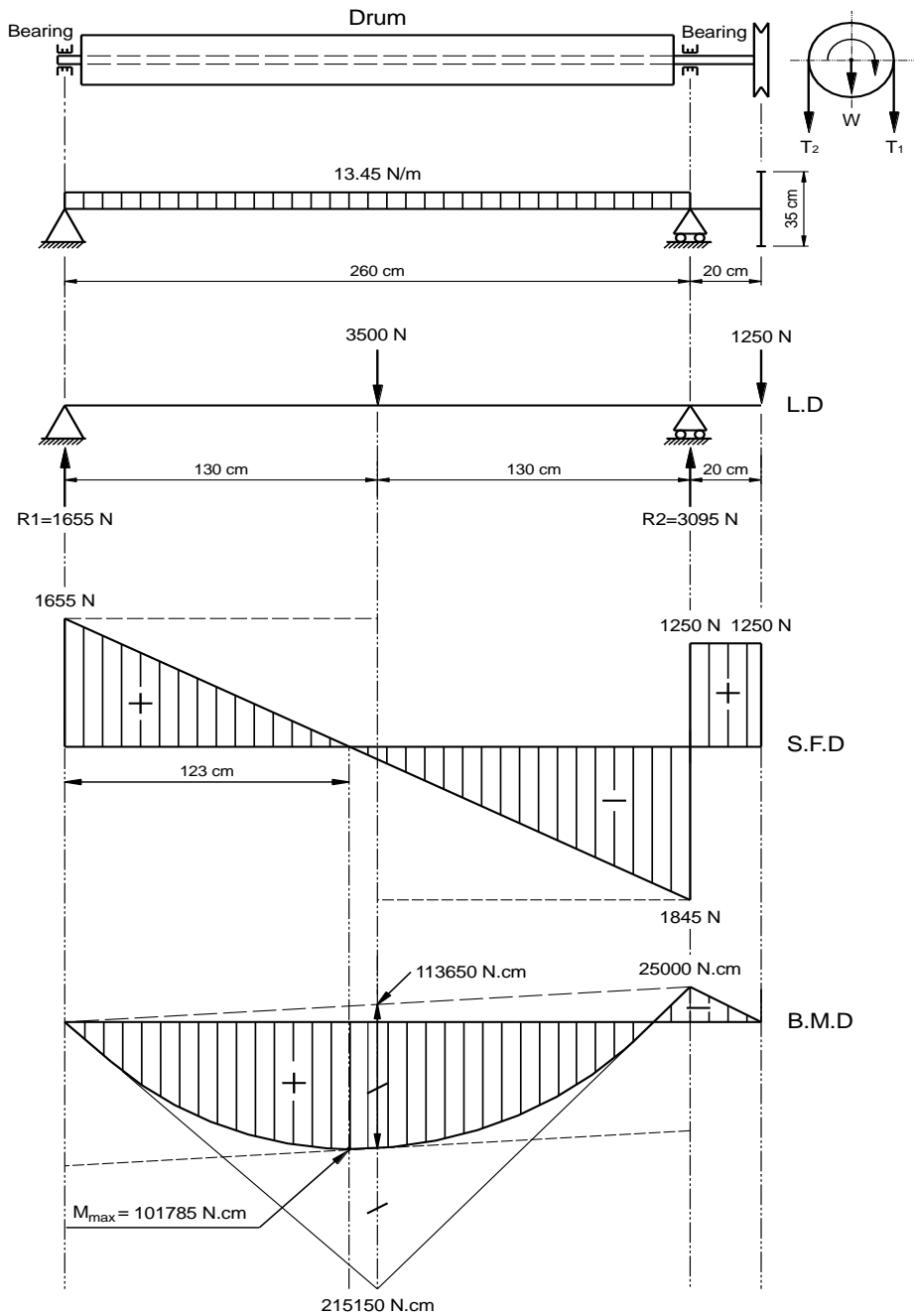

Fig. 3: Binding moment diagram of the screen shaft

From the bending moment diagram (Fig. 3), the maximum bending moment was found to be as follows:

$$M = 101785 \quad \text{N.cm}$$

The maximum torque can be calculated using the following equation **(Khurmi and Gupta, 1984)**:

$$\text{Power} = 2\pi N T / C$$

$$T = 716400 \text{ Power} / N \quad , \quad \text{N.cm}$$

$$T = 89550 \quad \text{N.cm}$$

- Then the maximum shear theory is applied:

$$\tau_{\max} = \frac{16}{\pi d^3} \sqrt{k_m^2 M^2 + k_t^2 T^2}$$

$$5000 = \frac{16}{\pi d^3} \sqrt{2^2 \times 101785^2 + 1.8^2 \times 89550^2}$$

So, from the above equation, $d = 66 \text{ mm}$

Then the shaft is designed at a 70 mm diameter

CONCLUSIONS

Theoretical analysis reveal that the local compost screening unit is preferred to be constructed under the following conditions:

- The sieve revolutions number should be lower than 43 rpm.
- The screen opening size should be of about 13 mm.
- The sieve inclination angle should be lower than 27 degrees.
- The motor power required must be not less than 3.68 kW.
- The machine shaft must be designed at a 70 mm diameter.

REFERENCES

- Amin, E.E.A. (2003).** Effect of some physical and mechanical properties on grading efficiency. Misr Society of Ag. Eng. Oct. 2003: 451 – 470.
- Bosoi, E. S.; O. V. Verniaev; I. I. Smimov and E. G. Sultan-Shakh (1991).** Theory construction and calculations of agricultural machines. Vol.(2), Mec. Pub. , Moscow.
- Khurmi, R. S. and J. K. Gupta (1984).** A textbook of machine designs. Eurasia Publishers house (Pvt.). New Delhi .P: 1067.

- Klenin, N. I. and V.A. Sakon (1980).** Farm machinery. Selakohazais Academy. Mach/ Kolos Pub., Moscow: 671
- Klenin, N.I.; I.F. Popov and V.A. Sakon (1985).** Agricultural machines. Theory of operation, computation of controlling parameters and the conditions of operation. Amerind publishing Co. PVT. Ltd., New Delhi.
- Page, N.; J. Leonard and G. Clark (2005).** Comparison of screening methods to refine MSW compost . Alberta Environment, Edmonton, Canada. BioCycle, 46(4): 57-58.
- Robert R., K. Maarten ; B. W. George ;E. S. Mark ; L. R. Tom ; J. K. John ; R. G. Francis ; L. J. Lucien ; K. David ; W. M. Dennis ; A. J. Harry and F. B. William (1992).** On-farm composting handbook. Northeast Regional Agricultural Engineering Service, 152 Kiley-Robb Hall, Cooperative Extension, Ithaca, NY 14853-5701, USA.
- Suzanne, F, F. Nicole and L. Daniel (2005).** Support Document for Compost Quality Criteria. Agriculture and Agri-Food Canada. 59 Camelot Drive. Nepean, Ontario K1A 0Y9.
- William F. B. (2000).** Compost quality standards & guidelines. New York State Association of Recyclers. Woods End Research Laboratory, Inc. P: 1 – 42.

الملخص العربي

المتطلبات الأساسية لتصميم وتصنيع وحدة محلية لتنظيف الكمبوست

*م. مريم محمد مصطفى **د. احمد فؤاد عبد المطلب ***د. اسعد عبد القادر در بالة
****د. طارق زكى فودة

يعتبر تراكم مخلفات المحاصيل الحقلية من أهم المشاكل الحيوية التي تمثل خطراً على البيئة. ويعتبر إعادة تدوير هذه المخلفات واستخدامها في إنتاج أسمدة عضوية أحد الحلول للتخلص منها بطريقة آمنة.

* طالبة دراسات عليا بقسم الميكنة الزراعية - كلية الزراعة - جامعة طنطا
**باحث أول بمعهد بحوث الهندسة الزراعية - مصر
***أستاذ مساعد بقسم الميكنة الزراعية - كلية الزراعة - جامعة طنطا
****أستاذ ورئيس قسم الميكنة الزراعية - كلية الزراعة - جامعة طنطا

ويعتبر تقليب كومات السماد العضوي المصنع من المخلفات الزراعية حتى مرحلة النضج ثم غربلة السماد الناضج من أهم العمليات التي يجب أن تجرى لإنتاج الأسمدة العضوية من المخلفات الزراعية. حيث تعمل عملية غربلة وتنظيف السماد العضوي الناتج بعد النضج من الشوائب على رفع جودة المنتج وتعمل على رفع سعر تسويقه. هذا ويتم عملية غربلة وتنظيف السماد العضوي في مصر إما بطريقة يدوية وهي تعد عملية شاقة تستلزم جهدا ووقتا كبيرا أو تتم بواسطة آلات مستوردة غالية الثمن لا تناسب المزارع الصغيرة.

لذا فقد اتجه هذا البحث الى محاولة وضع الأسس النظرية والتحليلات الرياضية اللازمة لتصميم وتصنيع وحدة تنظيف محلية في محاولة لرفع جودة المنتج وخفض تكاليف الإنتاج. اتجهت التحليلات النظرية الى محاولة التنبؤ بالقيم المثلى لكل من سرعة غربال التنظيف وقطر فتحات الغربال وزاوية ميل الغربال على الأفقي وكذلك حساب قدرة المحرك اللازم لتشغيل الآلة إضافة الى تصميم عمود الإدارة بالآلة.

وقد أظهرت نتائج التحليلات النظرية ما يلي:

- سرعة غربال التنظيف يجب أن تقل عن ٤٣ لفة/ الدقيقة.
- يجب أن تكون فتحات الغربال بقطر ١٣ ملم.
- يجب ألا تزيد زاوية ميل الغربال أثناء التشغيل عن ٢٧ درجة.
- يجب ألا تقل قدرة المحرك اللازم لإدارة الآلة عن ٣,٦٨ كيلوات .
- يجب أن يصنع عمود الإدارة بالآلة بقطر لا يقل عن ٧٠ ملم.