



**Journal of Engineering
Sciences Assiut University
Faculty of Engineering
Vol. 48, No. 5
September 2020
PP. 888-909**



STRENGTHENING OF REINFORCED CONCRETE SQUARE COLUMNS BY MEANS OF FERRO CEMENT JACKET

**Mohamed. O. Elsibaey¹, Zakaria. H. Awadallah², Omar. A. Farghal³,
Mohamed.Zakaria¹**

¹ *Civil Engineering Department, Aswan University, Egypt*

² *Structural Engineering Department, Al-Azhar University, Qena, Egypt*

³ *Civil Engineering Department, Assiut University, Egypt*

Corresponding author: Mohamedelsibaey2014@gmail.com

Received 21 April 2020; Revised 16 May 2020; Accepted 2 June 2020

ABSTRACT

This paper presents an experimental investigation to clarify the behaviour of reinforced concrete square columns strengthened using Ferro cement jacket. Strengthening using Ferro cement jacket is relatively a new technique, which has a high strength/weight ratio, good resistance to cracking and impact loading, acceptable resistance to fire, and more resistance to corrosion than traditional materials. Ten reinforced concrete short columns with nominal cross-sectional dimensions of 200 × 200 mm with a total length of 1200 mm were cast and tested under axial loading until failure. The main parameters in this study were the number of layers of wire mesh, type of wire mesh, and the cement mortar strength. The results showed the effectiveness of the Ferro cement jacket in improving the column capacity and reducing the vertical and lateral deformation. The results from the experiment were compared with the theoretical results obtained from the modified ECP 203 and modified ACI 318 equation codes.

Keywords: Ferro cement jacket, Square column, and Strengthening of Columns.

1. Introduction

Reinforced concrete (RC) columns are often classified because they are the most vital component of the building superstructure since load from slabs and beams are both transferred to columns. The total collapse of RC building may occur because of a change in service load and lack of column strength caused by deterioration. [1,2]. In the last few decades, the incidence of failure in reinforced concrete (RC) structures has been seen widely because of increasing service loads and/or durability problems. The economic losses due to such failures are millions of dollars. Many civil structures are not any longer thought safe because of overloading, below the style of existing structures or lack of internal control. To take care of efficient serviceability, older structures must be repaired or strengthened so that they meet an equivalent requirement demanded of the structures built today and in the future. [2]

Strengthening and repairing to increase the load-carrying capacity of the column can be performed by distilling degraded concrete, patch by non-shrink mortar, and then strengthened by steel jacketing or encased by additional RC. Ferro cement jacketing is one of the alternative methodologies of repair and strengthening of the column that is low value and straightforward to use to the existing column, as homemade. As described above, behaviours of columns strengthened by additional steel reinforcement and encased by Ferro cement under static loading are studied during this work. [3,4,17]. The main types of mesh used in Ferro cement applications are welded square wire mesh, hexagonal wire mesh, woven wire mesh, and expanded metal wire mesh, shown in **Fig 1**. In general, it can be stated that properties of the Ferro cement are greatly affected by the type, and the orientation of the reinforcement used. [2,5,6]

Ferro cement could be a slim and slender material, however, at the constant time sturdy. It provides a possible resolution to various issues in construction various kinds of structures shapes, conjointly once light-weight of the structure is predicted especially just in case of earthquake-prone areas as well as presents working solutions for repairs and strengthening works.

The strengthening of RC beams with Ferro cement laminates was studied by Paramasivam et al. (1990) the test can be observed on the effects of the level of damage to original beams prior to repair, and repeated loading on the performance of the strengthened beams. The study found that Ferro cement is a practical method for strengthening and rehabilitation of reinforced concrete structures.[17].

Sayan Sirimontree et al. (2015) studied the strengthening of reinforced concrete columns via Ferro cement jacketing by testing six reinforced concrete columns (one being referenced specimen and five being tested

columns wrapped by square welded wire mesh. The average compressive strength of mortar from the test is 21.7MPa. The main parameters were the number of wire mesh (7, 9, 11, 13, and 15). Results showed the optimum number of wrapping rounds of wire mesh is 13. Increasing of ductility is caused by the efficient confinement of wire mesh and mortar cement composite. [18]

Abeer M. Erfan et al (2019) Performed a laboratory and theoretical tests to study the structural performance of eccentric Ferro cement reinforced concrete columns and concluded that the expanded wire mesh exhibited higher ultimate load than conventionally reinforced control columns by about 36.7% for specimen which used three layers of expanded wire meshes. Also, the experimental results revealed that increased Ferro cement wire meshes as reinforcement contributed to slightly higher ultimate load, ductility, and higher energy absorption. [2]

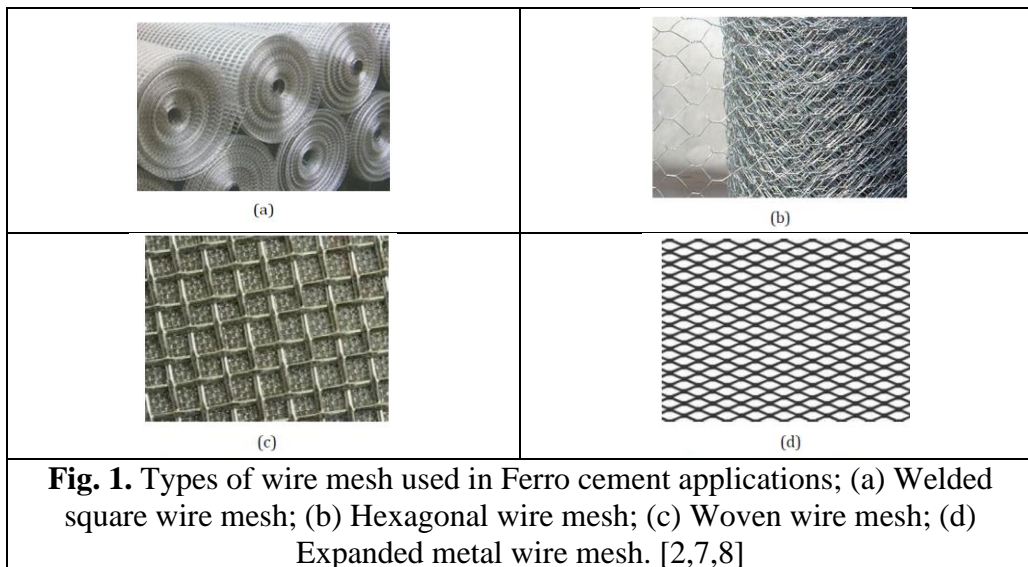

2. Experimental work

The experimental program was carried out to test 10 reinforced concrete columns to investigate the effect of the number of layers of wire mesh, type of wire mesh, and the mortar strength on the behaviour and strength of square columns regarding load capacity and lateral and axial deformations. All columns were 200×200 mm with a total length of 1200 mm and reinforced longitudinally with $4\Phi 12$ mm steel bars and $5\Phi 8$ mm/m steel stirrups. One of them was a control column (C0) without Ferro cement jacket. Three columns strengthening with expanded wire mesh with a two, three, or four layers (C1,

C2, and C3). Another three columns strengthening with square wire mesh with a two, three, or four layers (C4, C5, and C6). The last three columns (C7, C8, and C9) were strengthening using expanded wire mesh with three-mortar strength of 25, 30, and 40 MPa. All columns were tested under axial loading until failure. The details of the tested column are shown in **Fig 2** and **Table 1**.

2.1 Materials

Local natural sand, well-graded clean gravel with nominal sizes ranged from 10 to 20 mm, Ordinary Portland cement, additives as silica fume, and Sikament R2008 were used to form the components of the concrete and the cement mortar mixes. **Table 2** summarized the proportions of concrete mixer. The average concrete column strength in compression was 29.2 MPa. 12 mm steel bars were used as a compression steel and 8 mm diameter was used as stirrups. Two types of steel wire mesh were used (expanded and square) wire mesh. The mechanical properties of steel bars and wire mesh are given in **Tables 3** and **4**, respectively.

2.1.1 Mortar

The mortar is a mixture of cement, well-graded sand, water, and possibly some admixtures such as silica fume and superplasticizer. Like concrete, the mortar should have adequate workability, low permeability, and high compressive strength. The water-cement ratio, sand-cement ratio, quality of water, type of cement, and curing conditions in addition to the casting and compaction can influence the mechanical properties of the mortar. Three mixes of different water to cement ratio (0.45, 0.4, and 0.35) and (10, 15, and 25 %) of silica fumes were used for (25, 30, and 40) MPa cement mortar strength. To maintain uniform workability, the superplasticizer dosage was adjusted in the mix. Six cubes (size: 70.7 mm x 70.7 mm x70.7 mm) were used for compression test. The average cube strength at the time of testing was 25.2, 33.2 and 40.8 MPa, respectively. **Table 5** Shows the mortar mix proportions.

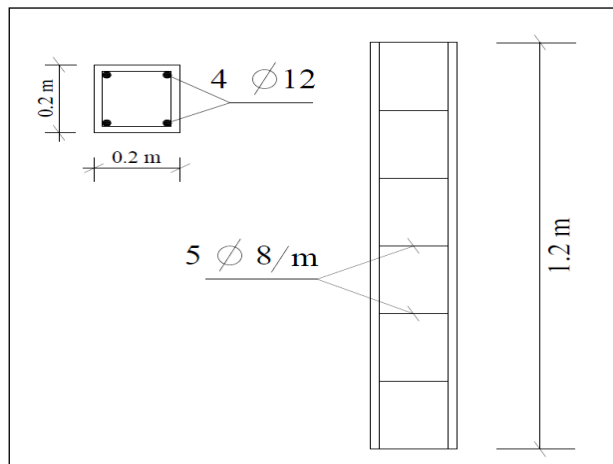

Fig. 2. Details of tested column.

Table 1. The details of the tested columns.

Group NO.	Column NO.	Layer Number	Mortar Strength (MPa) (Target values)	Layer Type
A	C0	-	-	-
B	C1	2	25	Expanded
	C2	3		
	C3	4		
C	C4	2	25	Square
	C5	3		
	C6	4		
D	C7	2	25	Expanded
	C8		30	
	C9		40	

Table 2. The concrete mix proportions ($f_{cu} = 25\text{Mpa}$)

Material	Weight Kg/m^3
Cement	350
Sand	625
Gravel	1295
Water	167
Silica fume	25
Sikament R2008	5

Table 3. Mechanical properties of steel bars.

Type of reinforcement	Diameter (mm)	Yield or Proof strength (MPa)	Ultimate Tensile strength (MPa)
steel bar	8	329	478
	12	488	681

Table 4. Mechanical properties of wire mesh (adopted from the supplier)

Type of Mesh	Opening Size (mm)	Weight (gm/m ²)	Diameter (mm)	Yield Tensile strength (MPa)	Ultimate Tensile strength (MPa)	Modules of Elasticity (Gpa)
Expanded mesh	19 * 33	17	1.5 * 2.1	225	334	136
Welded mesh	12 * 12	4.2	0.75	379	598	171

Table 5. The mortar mix proportions

Material	Mortar Mix proportions		
	Weight Kg/m ³		
	w/c = 0.45	w/c = 0.4	w/c = 0.35
Cement	400	450	500
Sand	1425	1370	1325
Water	180	180	175
Silica fume	10%	15%	25%
Sikament R2008	3.5 %	5 %	7%
Cement/Sand	1:3	1:3	1:3

2.2. Preparing Test Specimens and Test Procedure

2.2.1. Casting

Square steel moulds of 200 × 200 mm cross-section and 1200 mm in height were used for casting of concrete specimens. Before casting, their inner sides were coated with oil. After that, the concrete mix was prepared according to

the mix design and placed into the moulds. Ten square reinforced concrete columns were cast. All square columns were cast in a vertical position using steel moulds for the formwork. The prepared reinforcement cage was held carefully in the moulds. Concrete spacers of 15 mm size were used to maintain a 15 mm concrete cover to the main reinforcement. The concrete was poured in three layers and compaction of each layer was carried out using a vibration device, **See Fig 3.**

Table 6. Actual results for cubes of Mortar

Designation	Mortar Strength (MPa) Actual results for cubes After 28 days	Average mortar strength (MPa) Actual results for cubes	Mortar Strength (MPa))Target values)
Cube 1	25.1	25.2	25
Cube 2	25.31		
Cube 3	25.2		
Cube 4	33.2	33.2	30
Cube 5	33.1		
Cube 6	33.3		
Cube 7	40.4	40.8	40
Cube 8	40.8		
Cube 9	41.2		

2.2.2. Curing

After 24 hours of casting, all columns and cubes were de-moulded and cured under tapestry sheets until two days before testing to prepare the specimens for the test. **Fig 3** shows the Preparing of steel cage, casting and curing of the tested columns.

2.2.3. Jacket of columns with Ferro cement mesh

Nine Ferro cement jackets were cast. The skeleton of reinforcing mesh is a box section, which had 2 or 3 or 4 layers enclosed with a 20 mm mortar cover. The column specimens were jacketed with Ferro cement mesh after 28 days of curing. Jacketed specimens were again cured for 28 days. Full height jacketing was provided for all the specimens with an end gap of 20 mm at both ends to avoid direct loading on Ferro cement mesh. The final dimensions of the column were 220 × 220 mm. A steel float was

used to make the surface of the Ferro cement flat, and All samples were painted before testing. **See Fig 4.**



Fig. 3. Preparing of steel cage, casting, and curing of the tested columns.

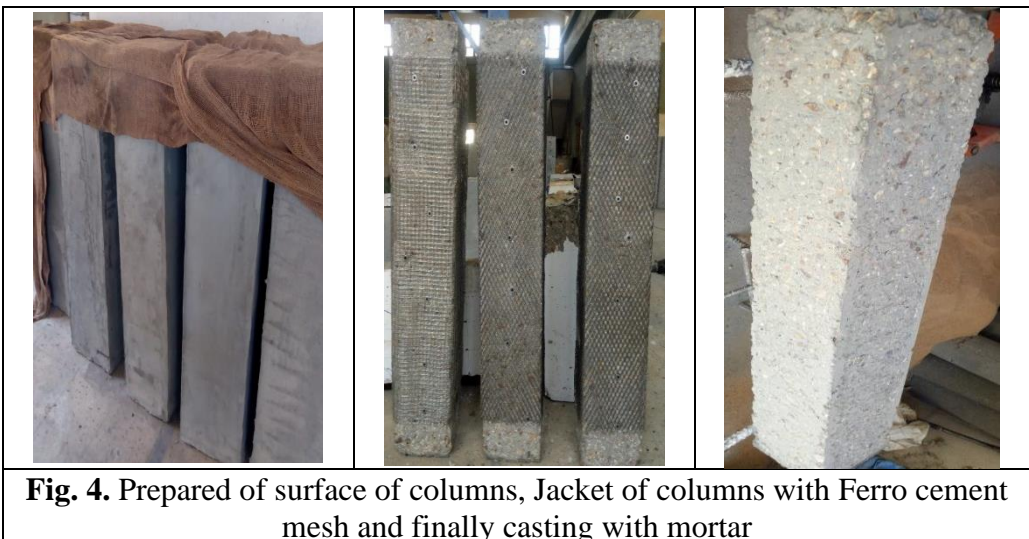

Fig. 4. Prepared of surface of columns, Jacket of columns with Ferro cement mesh and finally casting with mortar

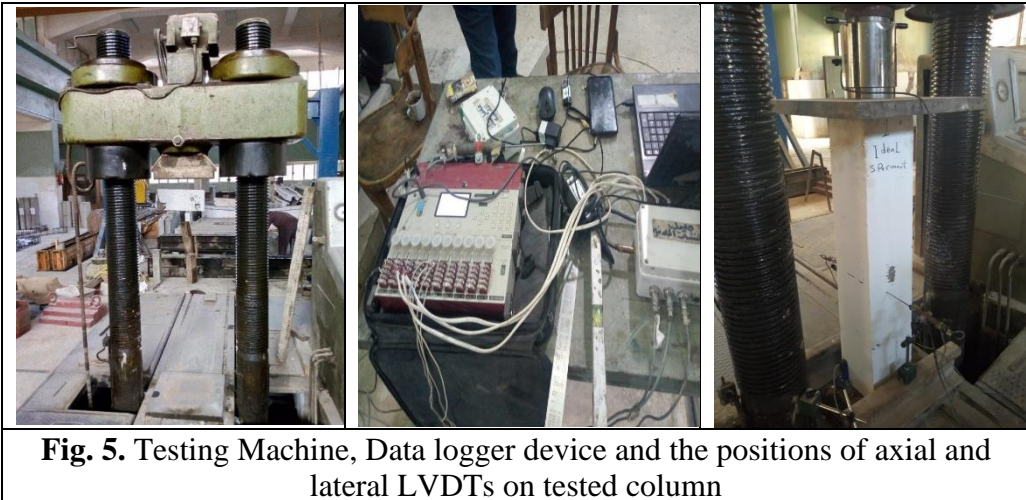

Fig. 5. Testing Machine, Data logger device and the positions of axial and lateral LVDTs on tested column

2.2.4. Instrumentation Device

Control and jacketed columns were tested under axial compressive loading in a 250 T hydraulic column testing machine. The test set-up is shown. Vertically of the column was ensured during the test to obtain a central loading on the column. A thin layer of cement paste was applied at the top and bottom of the column. Plates of the column-testing machine were ensured to be horizontal to eliminate the column to frame relative displacement. The axial and lateral displacements were recorded using linear variable differential transformers (LVDT). Ultimate load, axial and lateral deformation were recorded using data logger and failure modes of specimens were observed, See Fig 5.

3. Experimental results and discussion

Test results of the experimental program were discussed through crack pattern and mode of failure, ultimate load, vertical displacement, Horizontal displacement, and strains.

3.1. Crack pattern and mode of failure

Fig. 6, shows a total of ten columns specimens after failure. The typical collapse mechanism of the specimens was usually identified by sudden failure. The failure mode of each specimen is described in the following subsection.

3.1.1. Group (A):

The control specimen without any jacketing showed a sudden failure with explosive sound by bursting of concrete, suffered from excessive lateral expansion, and failed by splitting of concrete. The first crack was observed at a load of 3.5t. As the load reached the ultimate value of 70t, the column failed in compression. This is mainly interpreted by unstable propagation of the internal micro-cracks, followed by the strain softening, and eventually, the concrete strength loses its stiffness.

3.1.2. Group (B):

The first column in this group was (C1) which strengthening with two-layers of expanded wire mesh. As the load started, some low-level cracking sounds were heard which may be due to micro cracking of mortar. As the loading continued the specimen started to show vertical and horizontal displacement. As the load reached 30t some cracking and spalling of the surface of the mortar at the top, and near the bottom was observed. As the load reached the ultimate value of 84.75 t, the column failed in compression and complete crushing of concrete cover occurred in about one-fourth and last fourth of the column height. It was observed that after confinement with three-layer wire mesh the load-carrying capacity of the confined column (C2) increased to almost double as compared to the unconfined control columns. The first crack was observed at a load of 43 T. Cracks were vertical on all sides faces with spalling of the mortar layer from the wire mesh layer. The wire mesh continued to confine the column until the failure of the concrete occurred at a load of 108.75 T. The smash of the outer mortar layer can also be seen clearly in the figs. The third column in this group was (C3) which strengthening with four-layers of expanded wire mesh. At a load of 47 t, firstly, two cracks were observed simultaneously, one near upper left corner extending vertically towards mid-height and another was on right to half-width extending in a vertical pattern equally in height towards top and bottom. Suddenly, at load 81.8 t, the column began to a clear completely fail and smash of the mortar layer.

3.1.3. Group (C):

The confining of column (C4) with two-layers of square wire mesh increased the value of load and a decrease in the lateral displacement. The first crack was observed at a load of 30 t. Cracks were vertical on two adjacent faces with spalling of the mortar layer from the wire mesh layer. The wire mesh continued to confine the column until the failure of the core concrete occurred at a load of 81t. When three layers of square wire mesh were used in column (C5) the first crack was observed at a load of 12t right side of the column in a vertical direction, which continued to become wide as the load

increased. The failure occurred at an ultimate load of 80 t. The specimen failed in compression at one-fourth height from the top. The Strengthening with four layers of square wire mesh (C6) increased the value of the load. The first crack was observed at a load of 56 t left the side of the column in the vertical direction, which continued to become wide as the load increased. The column failed in compression when the load reached 82 t, which is the ultimate value.

3.1.4. Group (D):

(C7) was the first column in this group which strengthening with two-layers of expanded wire meshes and its strength of mortar was 25 MPa. The column was tested under axial load and the first crack appeared at a load of 41t. When the load reached the ultimate value of 83t, the column failed in compression and crushing of concrete cover was noticed. The column specimen, which is confined by Ferro cement jacket with two-layers of expanded wire mesh and with the strength of mortar 30 MPa in column (C8), spalling of Ferro cement jacket from the concrete surface was observed at an average load of 36t and the failure of columns was observed at an ultimate load of 93t. The spalling of concrete was observed entirely from the rupture zone, which also resulted in the bending of the longitudinal reinforcement as shown in Fig.

When the strength of mortar reached 40 MPa in column (C9) the column did not show any sign of cracking up to a load of 79 t. As the load approached 80t first crack was observed in the mortar layer with a cracking sound. The mortar layer of Ferro cement was separated from the wire mesh with compression failure of the column near one-fourth height from the base. The failure of the column occurred at a load of 106t.

3.2 Ultimate Loads:

From **Figs. 7–9** and **Table 6** it is seen that the axial load, carrying capacity of all Ferro cement jacketed columns specimens is higher than those obtained from the non-jacketed specimens. Group A for the control specimen (C0), the failure load was 70t.

3.2.1. Group (B) and (C):

In these groups, the increase in expanded or square wire mesh layer from two layers to three layers led to an increase in ultimate load capacity until failure. While, when the layer increased to four layers, the applied load increased rapidly until 85% of the ultimate load, and then this applied load decreased gradually. The control specimen failed at a load of 70t, while the specimens strengthened with two layers of expanded and square wire mesh (C1) and

(C4) collapsed at a load of 84t and 81t with about 20% and 16% increase in column strength respectively. The enhancement in the load-carrying capacity were 54% and 36 % when three layers of expanded and square wire mesh were used, (C2) and (C5). When four layers of expanded and square wire mesh were used in specimens (C3) and (C6), the ultimate load were 81t and 79t with about 16% and 14 % enhancement.

According to the results in **Table 6** and **Figs 7, 8, 9** the effect of using ordinary types of expanded wire mesh was more effective than the welded wire mesh. This enhancement was due to increased confinement due to small spaces between the wires of expanded mesh, which increased the failure load and enhanced the behaviour of the crack, which enhanced the whole behaviour of columns.

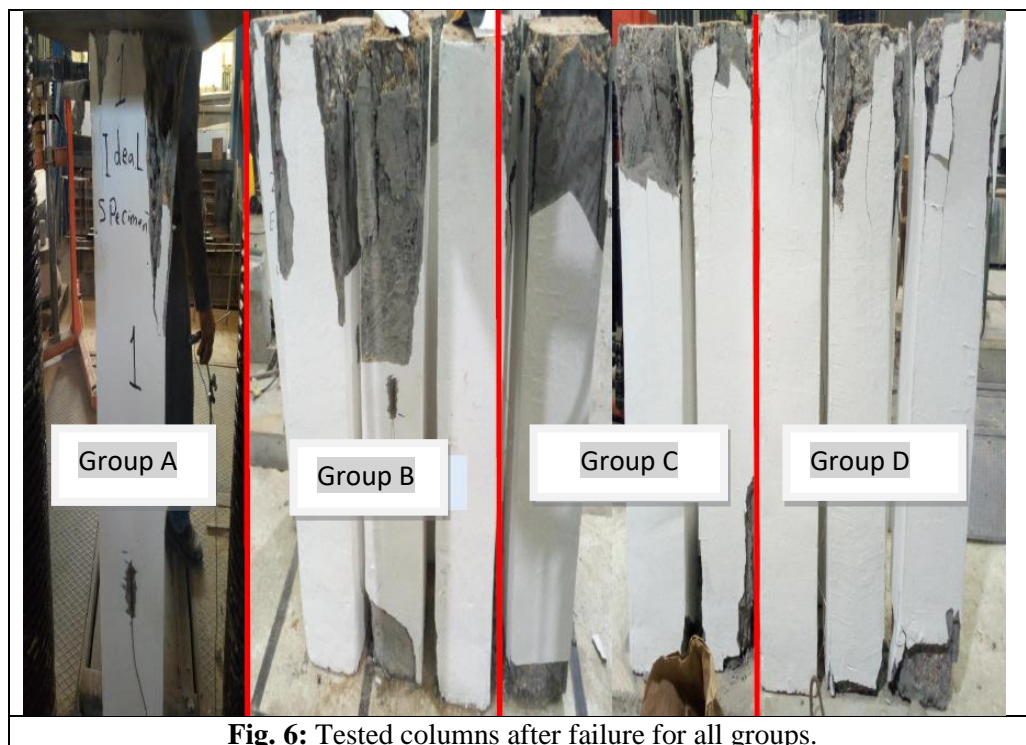
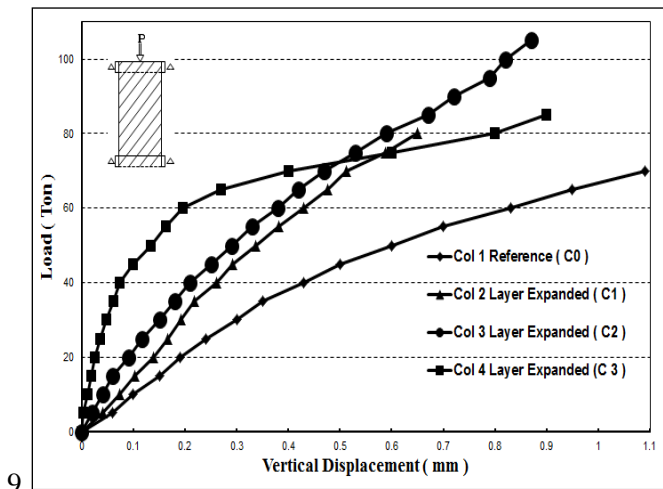

Fig. 6: Tested columns after failure for all groups.

3.2.1. Group (D):

In this group, the increase in mortar strength from 25 MPa to 40 MPa led to an increase in the ultimate load capacity from 83t to be 106t. Compared with the reference column, the ratio of this increase was 20% and 33% and 51% for columns (C7), (C8), and (C9) respectively. See **Fig.**



9. **Fig. 7.** Variation of load with respect to vertical displacement for columns in group (B) compared with reference column (A0).

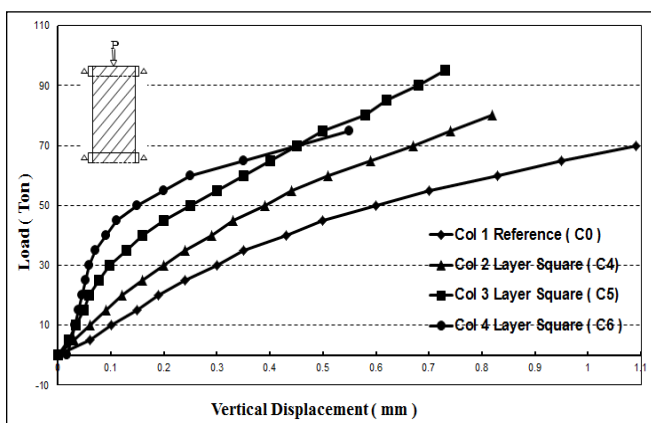

Fig. 8. Variation of load with respect to vertical displacement for columns in group (C) compared with reference column (A0).

3.3. Vertical Deformation

The load – vertical displacement curves for the square jacketed reinforced columns are shown in **Figs. 7 to 9**, respectively. It can be observed that the columns with three-layer wire mesh performed better. Also using two layers of expanded wire mesh with 40 MPa mortar strength gives a good performance in load – vertical displacement behaviour. This may be due to the column was previously loaded up to its failure and can no longer shows much ductile nature. **Figs 10** and **Figs 11** show the relationship between the applied load and the vertical displacement for columns with two and three

layers of expanded and square wire mesh. It is observed that the use of expanded wire mesh is better than using square wire mesh to strengthen the square reinforced concrete columns.

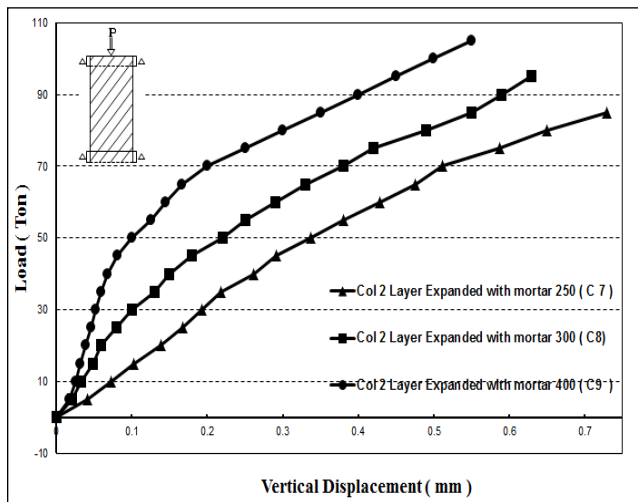

Fig. 9. Variation of load with respect to vertical displacement for columns in group (D)

Table 6: The results of strengthened column specimens compared with reference specimens

Group NO.	Column NO.	Ultimate load		Axial displacement mm	Lateral displacement mm
		ton	+		
A	C0	70	-	1.09	0.09
B	C1	84	20	0.73	0.86
	C2	108	54	0.79	0.78
	C3	81	16	0.9	0.95
C	C4	81	16	0.89	0.89
	C5	95	36	0.73	0.78
	C6	79	14	0.85	0.9
D	C7	83	19	0.72	0.85
	C8	93	33	0.63	0.80
	C9	106	51	0.55	0.60

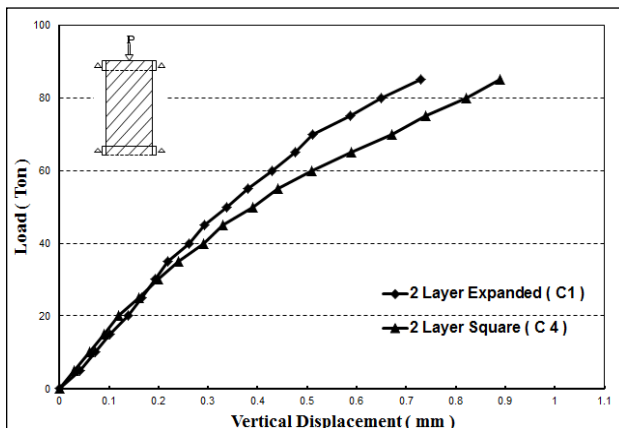

Fig. 10. Load – Vertical displacement relationship for column with two layers of expanded and square wire mesh.

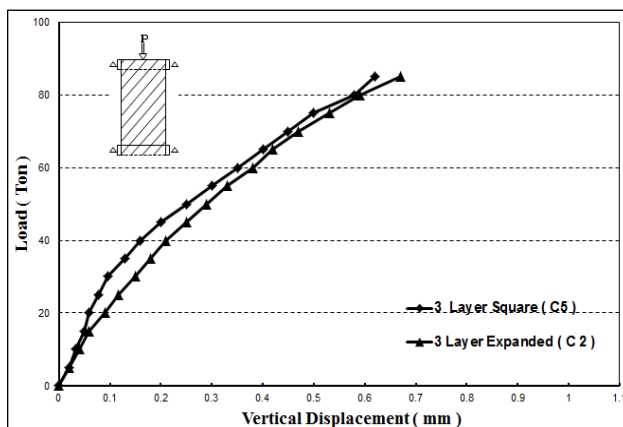

Fig. 11. Load – Vertical displacement relationship for column with three layers of expanded and square wire mesh.

3.4. Lateral displacement

For columns that were examined under axial loads, the lateral displacement was mostly affected by the increase in layers or increasing in cement mortar strength. From **Figs. 12–14** all jacketed columns with Ferro cement showed lower lateral displacement than the non-jacketed column at the ultimate load. The ratio between lateral deformations (Δ) at 0.8 of the ultimate loads in the descending part to the lateral deformation at the ultimate load was used to calculate the ductility index (ψ). The ductility obtained from the experimental test is shown in **Table 7**, as discussed below. The ductility index obtained for the control specimen (C0) was 1.06 but a progressive increase in ductility was obtained for different groups of specimens. In group (B), the ductility

increased from 1.25 to 1.72 and then decreased to 1.26. For group (C), the ductility increased from 1.23 to 1.63 and then dropped to 1.26. This decreased or dropped in the ductility due to using four layers of mesh. Group (D), the ductility varied from 1.25 to 1.83. The percentage of increase in ductility is shown in **Table 7**. A comparison between lateral displacement for column with two or three layers of expanded and square wire mesh were shown in **Figs 15 and 16**.

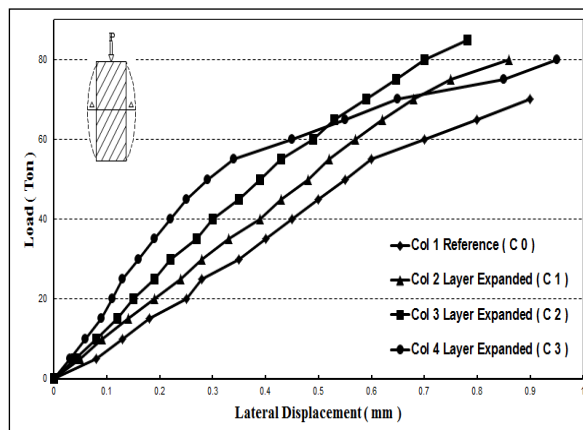

Fig. 12. Variation of load with respect to lateral displacement for columns in group (B) compared with reference column (A0)

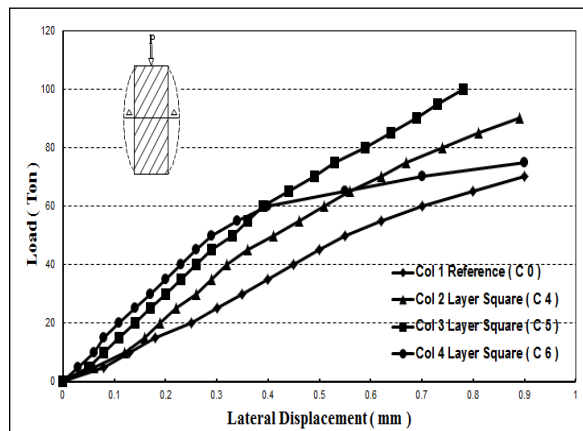

Fig. 13. Variation of load with respect to lateral displacement for columns in group (C) compared with reference column (A0)

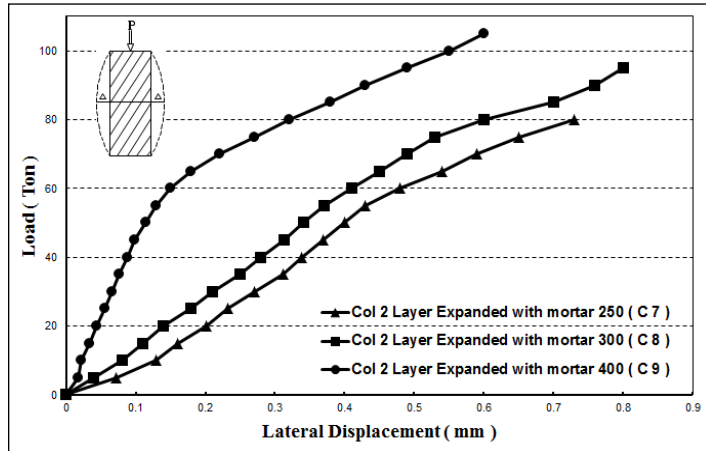

Fig. 14. Variation of load with respect to lateral displacement for columns in group (D) compared with reference column (A0)

Table 7: Deformation of the tested concrete columns

Group NO.	Column NO.	Ultimate load (ton)	Lateral deformation Δ (mm)	Ductility Index (ψ)	% of increase in ductility
A	C0	70	0.09	1.06	100
B	C1	84	0.86	1.25	117.90
	C2	108	0.78	1.72	162.26
	C3	81	0.95	1.26	118.86
C	C4	81	0.89	1.23	116.03
	C5	95	0.78	1.63	153.77
	C6	79	0.9	1.26	118.86
D	C7	83	0.84	1.23	116.49
	C8	93	0.80	1.59	150
	C9	106	0.60	1.83	172.64

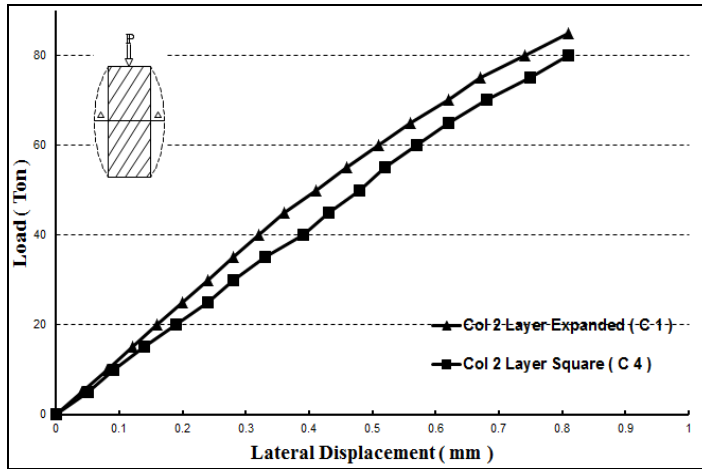

Fig. 15. Load – Lateral displacement relationship for column with two layers of expanded and square wire mesh.

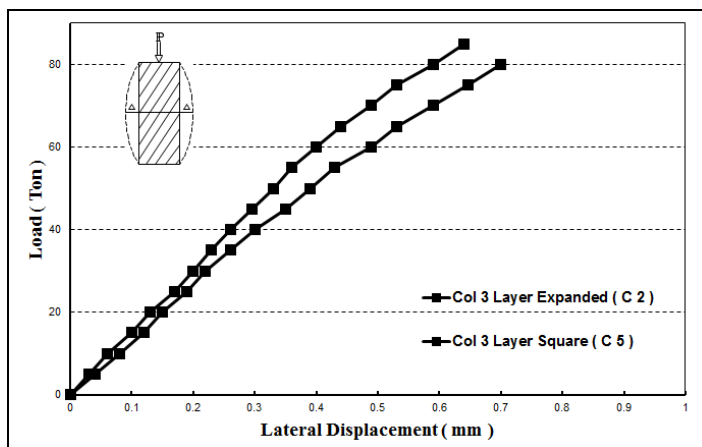

Fig. 16. Load – Lateral displacement relationship for column with three layers of expanded and square wire mesh.

4. Comparison between experimental and theoretical results

It can be said that Ferro cement is equivalent to RC, but its advantage is higher ductility due to the confinement of wire mesh composite with mortar cement. The Egyptian and American codes have been used for theoretical study as the basic equations for the ultimate load capacity:

Egyptian Code (ECP) Equation [8]

$$P_u = 0.35 A_c f_{cu} + 0.67 A_s f_y \tag{1}$$

ACI 318 Code Equation [6]

$$P_u = 0.85 A_c f_{cu} + A_s f_y \quad (2)$$

To study and know the significant improvement of static strength of all strengthened specimens, these equations were modified according to [2], [16],[18] to be as follows:

The modified Egyptian Code (ECP) Equations

$$P_u = 0.35 A_c f_{cu} + 0.67 A_s f_y + 0.95 A_{cf} f_{cf} + A_{sf} N f_{sf} \quad (3)$$

The modified ACI 318 Code Equations

$$P_u = 0.85 A_c f_{cu} + A_s f_y + 0.85 A_{cf} f_{cf} + A_{sf} N f_{sf} \quad (4)$$

Where:

P_u = Ultimate load capacity of column

f_{cu} = Concrete compressive strength

f_{cf} = Compressive strength of cement mortar

f_y = Yield strength of steel bars

A_c = Gross area of concrete

A_{cf} = Area of cement mortar

A_{sf} = Area of additional steel

N = Number of wire mesh layers

f_{sf} = tensile strength of wire mesh

Table 8. Comparison between experimental and theoretical results.

Column NO.	P_u (Ton) Experimental	P_u (Ton) Modified ECP - Code [5]	P_u (Ton) Modified ACI 318 Code [2]	P_{Uexp} / P_{Uth} Modified ECP	P_{Uexp} / P_{Uth} Modified ACI 318
C0	70	35.12	85.19	1.99	0.82
C1	84	59.57	109.57	1.40	0.76
C2	108	62.87	112.87	1.71	0.95
C3	81	66.17	116.17	1.22	0.69
C4	81	58.04	108.04	1.39	0.74
C5	80	60.58	110.58	1.32	0.72
C6	82	63.11	113.11	1.29	0.72
C7	83	58.86	108.27	1.38	0.75
C8	93	66.71	116.71	1.39	0.79
C9	106	70.28	120.28	1.50	0.88

Comparisons between the ultimate load-carrying capacities of all tested columns and the corresponding ultimate load predicted by Equations (3), (4). Equation (3) can be applied to predict maximum applied load-carrying capacity for both RC column and RC column strengthened by Ferro cement. According to the $P_{U_{exp}} / P_{U_{th}}$ Modified results as shown in **Table 8**, the values of the modified Egyptian code gives an overestimated value while the values obtained from the modified ACI code are underestimated.

5. CONCLUSION

This experimental study is carried out to analyse the behaviour of reinforced concrete square columns strengthened using Ferro cement jacket. Based on test results, observations, and discussions, some points can be concluded:

1. The confinement with Ferro cement techniques in reinforced concrete columns can improve the strength and ductility of strengthening.
2. Test results indicated that Ferro cement jackets made of 3 layers of non-structural expanded wire mesh and applied on square reinforced concrete columns have a promising performance on increasing its load capacity and enhancing its failure mode.
3. Confinement with three-layers of expanded wire mesh increased the strength up to 54% as compared to the specimen strengthened with two-layers of expanded wire mesh. In addition, the results showed that using expanded wire mesh was better than Using square wire mesh.
4. Using two layers of expanded wire mesh with 40 MPa mortar strength exhibited an increase in the ultimate load capacity of 51% than that with 25 MPa mortar strength.
5. The ductility index for column strengthen by three layers of expanded wire mesh was better than that strengthen by three layers of square wire mesh.
6. We concluded from the experimentally and theoretical results, that the values of the modified Egyptian code are overestimated and the values of the modified ACI code are underestimated.
7. We suggest changing and adjusting the modified equations to be more agreement with the experimentally results.

References

- [1] Abdullah and Takiguchi, K. (2003), "An investigation into the behaviour and strength of reinforced concrete columns strengthened with Ferro cement jackets". *Cement & Concrete Composites*, vol. 25: pp 233–242.
- [2] Abeer M. E, Hossam H. A, Bishoy A. M, and Taha A. El-Sayed, (2019)," Structural Performance of Eccentric Ferro cement Reinforced Concrete

- Columns" *Nanoscience and Nanotechnology journal*, Volume 11, SP 1213- EP 1225.
- [3] A.B.M.A. Kaish, M. Jamil, S.N. Raman, M.F.M. Zain, L. Nahar, "Ferro cement composites for strengthening of concrete columns": A review *Construction and Building Materials*, 160 (2018), pp. 326-340
- [4] A. B. M. A. Kaish, (2016), "An approach to improve conventional square Ferro cement jacket for strengthening application of Short Square RC column. Faculty of Engineering & Built Environment, Universiti Kebangsaan Malaysia, 43600 UKM Bangi, Selangor, Malaysia.
- [5] American Concrete Institute (ACI), (1988). "Guide for the Design, Construction, and Repair of Ferrocement". ACI 549, Detroit, American Concrete Institute.
- [6] American Concrete Institute (ACI), (2008). "Building Code Requirements for Structural Concrete" (ACI 318-08) and Commentary (ACI 318R-05). Detroit, American Concrete Institute.
- [7] Afaf H Abdallah, Abeer M. Erfan, Taha A. El-Sayed, (2019,) Experimental and analytical analysis of lightweight Ferro cement composite slabs. *Engineering Research Journal (ERJ)*, Vol. 1, No. 41 July 2019, pp. 73-85.
- [8] Egyptian Code for Design and Construction of Reinforced Concrete Structures (ECP 203- 2007) - (ECP 203- 2018).
- [9] El-Sayed, T.A. and Erfan, A.M. (2018), "Improving shear strength of beams using Ferro cement composite". *Construction and Building Materials*, 172, pp.608–617.
- [10] Jianqi Wang, (2013), "Behavior of Ferro cement columns under static and cyclic loading" Doctor of Philosophy, in the Faculty of Manchester for Engineering and Physical Sciences.
- [11] Ornela Lalaj, (2015), "Recent perspectives for ferrocement" *Res. Eng. Struct. Mat.* Vol. 1 Iss.1 (2015) 11-23.
- [12] Kaish, A. B. M. A, Alam, M. R., Jamil, M. & Waheed, M. A., (2013). "Ferro cement Jacketing for restrengthening of Square Reinforced Concrete Column under Concentric Compressive Load". *Procedia Engineering*, 54 (0), 720-728.
- [13] Kim, J.-K. & Lee, S.-S., (2000). "The behaviour of reinforced concrete columns subjected to axial force and biaxial bending". *Engineering Structures*, 22 (11), 1518-1528.
- [14] Mansur, M. & Paramasivam, P., (1985). "Ferro cement under combined bending and axial loads. *International Journal of Cement Composites and Lightweight Concrete*, 7 (3), 151-158.
- [15] Mourad, S. & Shannag, M., (2012). "Repair and strengthening of reinforced concrete square columns using Ferro cement jackets". *Cement and Concrete Composites*, 34 (2), 288-294.
- [16] Nedwell, P., Ramesht, M. & Rafei-Taghanaki, S. (1994)" Investigation into the repair of short square columns using ferrocement, FERRO CEMENT INTERNATIONAL SYMPOSIUM, 1994. 277-285.
- [17] Paramasivam, P., Lim, C. T. E., & Ong, K. C. G. (1998). "Strengthening of RC beams with Ferro cement laminates". *Cement and Concrete Composites*, 20(1), 53-65.

- [18] Sayan Sirimontree, Boonsap Witchayangkoon and Krittiya Lertpocasombut, (2015). " Strengthening of Reinforced Concrete Column via Ferro cement Jacketing". American Transactions on Engineering & Applied Sciences. Volume 4 No.1 ISSN 2229-1652 eISSN 2229-1660, pp 39-47.

تقوية الأعمدة الخرسانية المربعة بما يعرف بتقنية الفيروسمنت

الملخص العربي

تقدم هذه الورقة البحثية نتائج معملية تجريبية لتوضيح سلوك الأعمدة الخرسانية المربعة المقواة باستخدام تقنية الفيروسمنت. التقوية باستخدام تقنية الفيروسمنت تعتبر تقنية جديدة نسبياً ولها قوة عالية مقارنة بوزنها ومقاومة للشروخ وأحمال الصدمات ولها مقاومة مقبولة للحريق وهي أكثر مقاومة للتآكل أكثر من المواد التقليدية. تم صب واختبار عشرة أعمدة من الخرسانة المسلحة بأبعاد ذات مقطع عرضي 200×200 مم بطول إجمالي 1200 مم واختبارها تحت التحميل المحوري حتى الانهيار. كانت العوامل الرئيسية في هذه الدراسة هي عدد طبقات سلك الشبك المعدني، ونوع سلك الشبك ومقاومة المونة. أظهرت النتائج فاعلية تقنية الفيروسمنت في تحسين تحميل العمود وزيادة الصلابة وتقليل الإنحناء العمودي والجانبى. تمت مقارنة النتائج المعملية مع النتائج النظرية التي تم الحصول عليها من الكود المصري والكود الأمريكي المعدل.

الكلمات الدلالية: تقنية الفيروسمنت، الأعمدة الخرسانية المربعة، وتقوية الأعمدة الخرسانية.