

## EXPERIMENTAL STUDY ON HEAT TRANSFER AND FRICTION OF TURBULENT SWIRLING AIR FLOW THROUGH ABRUPT EXPANSION

**A. Khalil<sup>1</sup>, A.E. Zohir\* and A.M. Farid\***

<sup>1</sup> Mechanical Power Eng. Dept., Faculty of Engineering, Tanta University, Tanta, [akhalileg@yahoo.com](mailto:akhalileg@yahoo.com)

\* Mechanical Eng. Dept., Tabbin Institute for Metallurgical Studies, Cairo

(Received April 4, 2010 Accepted May 5, 2010).

*Heat transfer and pressure drop characteristics of turbulent swirling air flow through a sudden expansion pipe with different swirl angles and different sudden expansion ratios were investigated experimentally. The effect of the sudden expansion ratio, Reynolds number, vane angle and swirl generator location on the heat transfer and pressure drop were examined. The test pipe is uniformly heated and the Reynolds number ranges from 9,000 to 41,000. It was found that inserting a swirl generator inside sudden expansion pipe causes an increase in both the relative mean Nusselt number and the enhancement efficiency of the tested pipe. The enhancement efficiency increases with Reynolds number decreasing while it increases with the increase in sudden expansion ratio and vane angle. A maximum efficiency up to 405% could be achieved. Correlations for Nusselt number and friction factor for the swirl flow are obtained and the performance evaluation criterion to access the real benefits in using the swirl generators of the enhanced tube is discussed.*

**KEYWORDS:** Sudden expansion, swirl flow, heat transfer, friction factor, enhancement efficiency.

### NOMENCLATURE

<p><math>C_p</math> Specific heat capacity of the fluid, J/kg.K</p> <p><math>D</math> Upstream pipe diameter, m</p> <p><math>D</math> Test section Pipe diameter, m</p> <p><math>F</math> Friction factor</p> <p><math>H</math> Heat transfer coefficient, W/m<sup>2</sup>.K</p> <p><math>H</math> Step height, <math>H = 0.5(D-d)</math>, m</p> <p><math>K</math> Thermal conductivity of the fluid, W/m.K</p> <p><math>L</math> Test section pipe length, m</p> <p><math>m</math> Mass flow rate, kg/s</p> <p><math>Nu</math> Nusselt number</p> <p><math>\Delta P</math> Pressure drop, Pa</p> <p><math>q</math> Heat flux, W/m<sup>2</sup></p> <p><math>Q</math> Heat transfer rate, W</p>	<p><math>U</math> Flow velocity, m/s</p> <p><math>S</math> Swirler position, m</p> <p><b>Greek Symbols</b></p> <p><math>\theta</math> Swirl generator vane angle, °</p> <p><math>\mu</math> Viscosity of the fluid, N.s/m<sup>2</sup></p> <p><math>\eta</math> Efficiency</p> <p><math>\rho</math> Density, kg/m<sup>3</sup></p> <p><b>Subscripts</b></p> <p><math>m</math> Mean</p> <p><math>x</math> Local</p> <p><math>o</math> Smooth pipe (<math>d/D = 1</math>) without swirl</p> <p><math>i</math> Inlet</p> <p><math>e</math> Exit</p> <p><math>b</math> Bulk</p>
--	---

$Re$	Reynolds number	$r$	Relative
$T$	Temperature, °C	$s$	Surface
$X$	Distance, m	$h$	Heated

## 1. INTRODUCTION

In the last decades, many different techniques were used to enhance the heat transfer coefficient. Swirling flow and sudden expansion pipe are two kinds of those techniques. Those techniques are used in many applications such as chemical and mechanical mixer, separation devices, combustion chamber and heat exchangers. Swirling flow is an effective method used to increase the heat transfer rate through pipes with no need to add any external power (passive techniques). The turbulent swirl flow through an abrupt axisymmetric expansion is a complex flow possessing several distinctly different flow regimes of recirculation and extremely high levels of turbulence. The heat transfer characteristics are often significantly altered by the nature of the flow separation and subsequent flow redevelopment. Swirl flow can be induced by different kinds of swirl generators such as injection, twisted tape, helical screw, vanes, etc.

The different parameters of swirling flow generated by injection were studied experimentally by Akpınar *et al.* [1, 2] and Çakmak and Yıldız [3]. They studied the effect of holes diameter, holes number and angle of injection on the heat transfer rate and pressure drop. They found that, using injector to create swirling flow enhances heat transfer rate but it increases the pressure drop and requires more pumping power. Another type of swirl generator is the snail entry. The influence of snail entry on heat transfer rate was examined by Promvong and Eiamsa-ard [4, 5]. They used snail entry with conical nozzle and the efficiency was less than unity. Promvong [6] used square or circular coiled wire with snail entry to increase the efficiency but the efficiency was still about unity. Zahaby *et al.* [7, 8] studied the effect of surface ejection and injection on heat transfer and flow field for air flowing in a rectangular duct. They found that Nusselt number may be increased up to 360% but friction factor has been found to doubled up to 200%.

Twisted tape was examined by many researchers as a swirl generator. Saha *et al.* [9, 10] studied the influence of length, twisted ratio, width, phase angle and rod diameter on heat transfer and pressure drop. Hong and Bergles [11] used twisted tape with different twisted ratio to reduce the size of the heat exchanger. Increasing in the heat transfer rate by up to 100% was found by Yildiz *et al.* [12] using stripes twisted tape. An increase in the heat transfer coefficient between 1.28:2.4 was found by Chang *et al.* [13] used broken twisted tape.

Gül and Evin [14] used short length helical screw to enhance the heat transfer inside pipe. They achieved a net energy gain up to 20% depending upon Reynolds number, tape angle and channels number. Many researches studied the swirling flow formed by inserting a propeller vane swirl generator inside pipe experimentally and numerically. Bali [15] and Bali and Ayhan [16] studied the effect of the propeller vane when it fixed at the tube entrance or at the tube end on the heat transfer rate. They found that the results of heat transfer and pressure drop, when the vane fixed at the tube end, was better than that found when the vane was fixed at the tube entrance.

Zaherzadeh and Jagadish [17] and Sarac and Bali [18] studied the influence of different propeller vane parameters (blade width, diameter, blades number, vane angle and swirl generator) on the heat transfer and pressure drop inside pipe. They found that Nusselt number and pressure drop increased with blades number increasing. Also Nusselt number and pressure drop increased with vane angle decreasing. A continuous swirling flow induced by more than one propeller vane inserted inside pipe at equal interval distance was studied by [19 – 23]. They examined the effect of different parameters like (vane angle, number of swirl generator, blades number...etc) on the heat transfer rate and pressure drop. They found that; using more than one propeller vane gave results better than using a full length twisted strips. They also found that Nusselt number and efficiency increased with vane angle decreasing, except for Eiamsa-ard *et al.* [23] who found that the efficiency and the heat transfer increased with vane angle increase. Numerical studies for turbulent swirling flow characteristic through sudden pipe expansion were done by Vanierschot and Bulck [24], who found that the reattachment length for swirling flow through sudden expansion depends on the swirl number, expansion ratio and the reattachment length at zero swirls. Dellenback *et al.* [25] and [26] studied the effect of swirling motion created by injectors inside sudden pipe expansion on the velocity and heat transfer. They found that as swirl number increased from zero to 1.2, the peak local Nusselt number increased from 3 to 9.5 times larger than fully developed value and its location moved towards the inlet.

The present work investigates the heat transfer, pressure drop and efficiency enhancement for swirling flow through sudden pipe expansion. Propeller swirl generator with vane angles ( $15^\circ$ ,  $30^\circ$ ,  $45^\circ$  and  $60^\circ$ ) is inserted at distance  $S = H$ ,  $3H$ ,  $5H$ ,  $10H$ ,  $20H$  and  $40H$  from the test pipe entrance to increase the heat transfer inside sudden pipe expansion (sudden expansion ratio  $d/D = 0.32$ ,  $0.46$  and  $0.61$ ). Air with flow Reynolds number ranged from 9000 to 41000 was used as the working fluid.

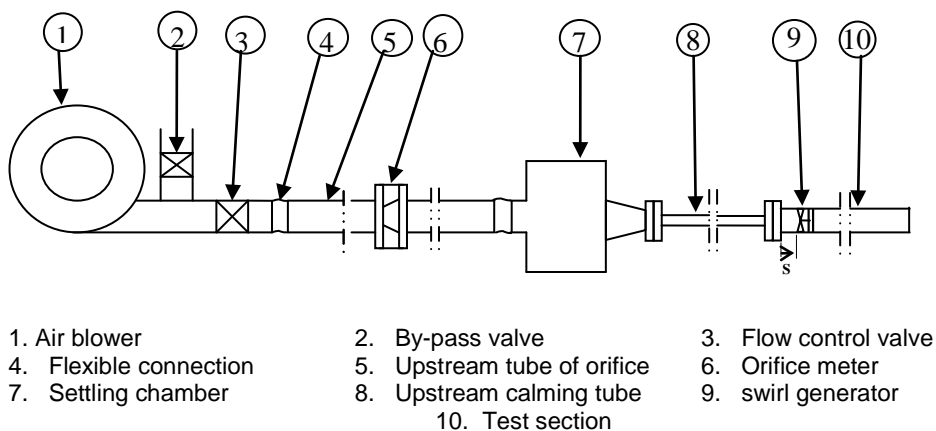
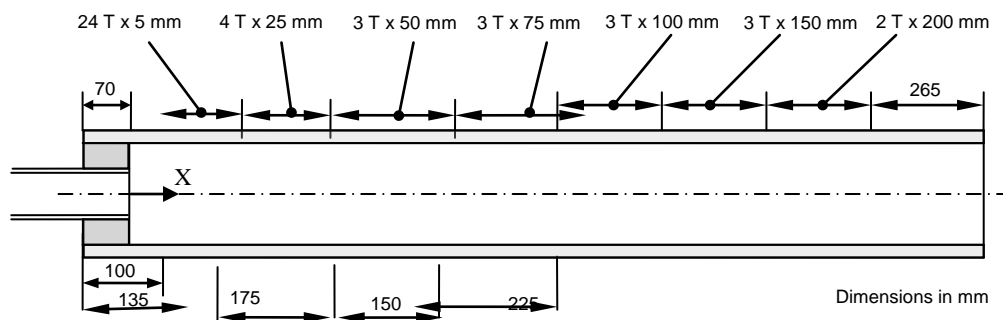

Fig. 1 Test rig layout.



**Fig. 2** Thermocouple distribution on the downstream test pipe.



**Fig. 3** Photograph of a swirl generator.

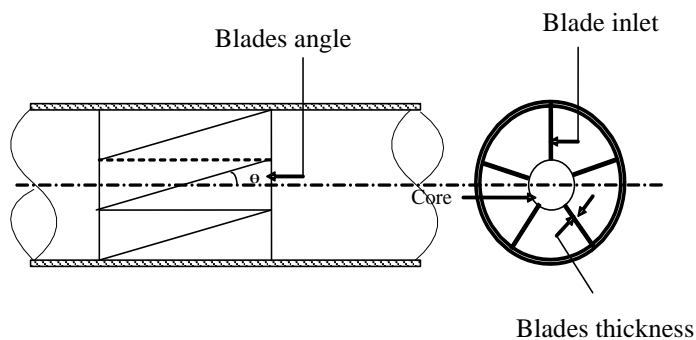

**Fig. 4** Details of swirl generator.

## 2. TEST RIG

The test rig consists of a 7.0 HP blower that blows atmospheric air into the test tube through the control unit, as shown in Fig. 1. The control unit consists of control valve and by-pass valve, and then the air passes through the orifice meter. The air is then passed through the settling chamber, which is used to damp the flow instability, and delivered air to the test section. The test section consists of upstream and downstream pipe. The upstream pipe is a PVC tube with diameter  $d = 25, 37.5$  and  $50$  mm and length  $= 20d : 25d$  to have a fully developed flow. The downstream pipe consists of a main pipe made of stainless steel with diameter  $D = 82$  mm and  $2000$  mm length. The main pipe is heated by eleven heaters wound around the tube with  $1$  mm pitch to achieve a uniform heat flux. Sheets of aluminum of  $0.2$  mm thickness were wound above and under the heaters to distribute the heat uniformly. Then a layer of glass wool insulation ( $50$  mm thickness) was employed to cover the pipe to minimize the heat loss to the atmosphere. The surface temperatures were measured by 49 thermocouple of K type. The thermocouples were located at different axial positions with spacing ranged from  $5$  mm near the sudden expansion corner to  $200$  mm near the exit as shown in Fig. 2. The swirling flow is induced by propeller vane as shown in Figs. 3 and 4. The core of the propeller vane is made of Artelon and has  $18$  mm diameter and  $50$  mm length.

The blades are made of aluminum 0.4 mm thickness. The propeller vane has 80 mm outer diameter and 5 blades fixed at  $\theta = 15^\circ, 30^\circ, 45^\circ$  or  $60^\circ$ . The propeller vane is installed at distance from the sudden expansion corner  $S = H, 3H, 5H, 10H, 20H$  or  $40H$ . The swirl generators with vane angle  $\theta = 15^\circ, 30^\circ, 45^\circ$  and  $60^\circ$  are referred to as swirler 1, 2, 3 and 4; respectively.

### 3. ANALYSIS

The net heat transfer by convection to air can be calculated from Eq. (1). The local mean bulk temperature of air in each segment of the test section is calculated from Eq. (2). The properties of air are determined at mean bulk temperature. The heat lost  $Q_{loss}$  has been measured using Fourier's law of radial heat conduction by measuring the outer surface temperatures of the insulation at the corresponding points where the tube wall surface temperature were measured. The heat loss was found to vary between 5% and 6% of the heater input power. In the analysis  $Q_{loss}$  was assumed to be 6%.

$$Q_{net} = (Q - Q_{loss}) = \dot{m} C_p (T_{be} - T_{bi}) \tag{1}$$

$$T_{bx} = T_{bi} + \dot{q}_o \pi D L_x / \dot{m} C_p \tag{2}$$

where  $\dot{q}_o$  is the uniform heat flux and can be calculated from

$$\dot{q}_o = const. = Q_{net} / \pi D L_h \tag{3}$$

The local and mean heat transfer coefficients are determined from Eqs. (4) and (5). The local and mean Nusselt number can be calculated, respectively, from Eq. (6).

$$h_x = \dot{q}_o / (T_{sx} - T_{bx}) \tag{4}$$

$$h_m = \frac{1}{L} \int_0^{L_h} h_x dL_x \tag{5}$$

$$Nu_x = h_x D / k$$

$$Nu_m = h_m D / k \tag{6}$$

The friction factor can be calculated from Darcy equation (7).

$$\Delta P = f \frac{L \rho u^2}{D} \tag{7}$$

where  $\Delta P$  is the pressure drop across the test pipe which measured between two point before the sudden expansion and the end of the test section. Due to the enlargement in the diameter of the pipe,  $\Delta P$  may have a negative or positive value according the investigated independent parameters.

The enhancement efficiency  $\eta$  is defined as the ratio of the heat transfer coefficient for the inserted tube  $h_m$  to that for the plain tube  $h_o$  at the same pumping power and it may be more than unit according to ref [4, 6 and 23].

$$\eta = [h_m / h_o] \tag{8}$$

An error analysis is carried out for the relevant parameters and the average uncertainties are found to be:  $\pm 1.09\%$  for mean velocity,  $\pm 1.09\%$  for Reynolds number,  $\pm 4.8\%$  for Nusselt number,  $\pm 1.05\%$  for friction factor and  $\pm 4.9\%$  for the enhancement efficiency.

## 4. RESULTS AND DISCUSSIONS

The experimental investigations for swirling flow induced by propeller vane swirl generator with vane angle ( $\theta = 15^\circ, 30^\circ, 45^\circ$  and  $60^\circ$ ) located at position  $S = H, 3H, 5H, 10H, 20H$  and  $40H$  through sudden expansion pipe, of uniform heat flux, with expansion ratios of ( $d/D = 0.32, 0.46$  and  $0.61$ ) are described in this section. The inlet air temperatures were varied between  $25\text{--}40^\circ\text{C}$  while the exit air temperatures were varied between  $40\text{--}60^\circ\text{C}$ . First, the experiments were done for heat transfer inside smooth pipe ( $d/D = 1$ ) without swirl. The results were compared with Dittus–Boelter [28] correlation to check the validity of the experimental data and a good agreement between the experimental results and Dittus–Boelter equation was achieved with deviation  $\pm 6\%$  as shown in Fig. 5.

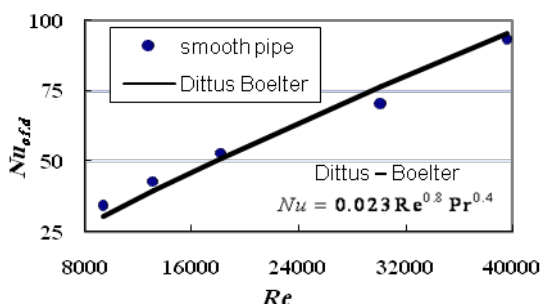

Fig. 5 Comparison of results for flow in pipe without swirl and that of Dittus–Boelter Eq.

### 4.1 Influence of Sudden Expansion Only

The influence of sudden expansion only on the local Nusselt number at different Reynolds numbers was studied. As shown in Fig. 6, local Nusselt number decreases to a minimum value between  $X = 0.01: 0.015$  ( $X/H = 1$  and  $X/H = 1.5$ ) due to the counter rotating eddy beneath the corner. This minimum value is clear at high sudden expansion ratios (low  $d/D$  value) and agreed with the results of Baughn *et al.* [30]. After that local Nusselt number increases gradually to a peak value near the reattachment point (the point where the flow becomes in contact with pipe walls after separation) due to boundary layer distortion. Then the local Nusselt number decreases to a fully develop value. With an increase in the Reynolds number the local Nusselt number increases. The influence of sudden expansion ratio on the relative local Nusselt number at different Reynolds numbers is shown Fig. 7. The relative local Nusselt number is the value of local Nusselt number normalized by the corresponding local Nusselt number for constant area pipe ( $d/D = 1$ ). Fig. 7 shows that, at the same Reynolds number, as the sudden expansion ratio increases ( $d/D$  decreases) the Nusselt number increases and the position of the maximum Nusselt number moves slightly away from the inlet. A maximum enhancement in relative local Nusselt number by up to 3.56 times is obtained with  $d/D = 0.32$  and  $Re = 10,000$  at position  $X/H = 11.4$ . The effect of inserting swirl generator inside sudden pipe expansion on the relative local

Nusselt number is shown in Figs. 8–11. Figures show that inserting swirl generator inside sudden expansion pipe increases the heat transfer coefficient. In addition, Figures show that the local Nusselt number for swirling flow through sudden pipe exposition has similar trend as that of the sudden expansion only. But when the swirl generator was inserted inside pipe the length of the recirculation zone decreases and the peak local Nusselt number moves towards the inlet. As seen from Fig. 10; the peak relative local Nusselt number increases with increasing vane angle and moves towards the inlet. Also at small vane angle; the peak relative local Nusselt number increases with the distance  $S$  increasing (distance between the location of the swirl generator and the sudden expansion) and move away from the entrance. At high vane angle; the peak relative local Nusselt number increases with decreasing the distance  $S$  and moves towards the inlet.

### 4-2 Influence of Reynolds Number

The effect of Reynolds number on the heat transfer is shown in Figs. 12 and 13. The figures show the relative mean Nusselt number  $Nu_{mr}$  (normalization of  $Nu_m$  of sudden expansion with swirl flow by  $Nu_{mo}$  for smooth pipe ( $d/D = 1$ ) without swirl) versus  $Re$  at different  $d/D$  values and different vane angles. Figures show that for all Reynolds numbers, the value of  $Nu_{mr}$  are above unity which mean that inserting swirl generator through sudden expansion pipe increases the heat transfer rate. As shown in figures 12 and 13,  $Nu_{mr}$  increases or decreasing with decreasing  $Re$  depending on  $d/D$  with swirl flow. This is due to the increase in  $Nu_m$  for smooth pipe ( $d/D = 1$ ) with  $Re$  increasing is higher than that for swirling flow sudden expansion pipe. The influence of  $Re$  on the friction factor is shown in Figs. 14 and 15. The friction factor decreases with increasing Reynolds number.

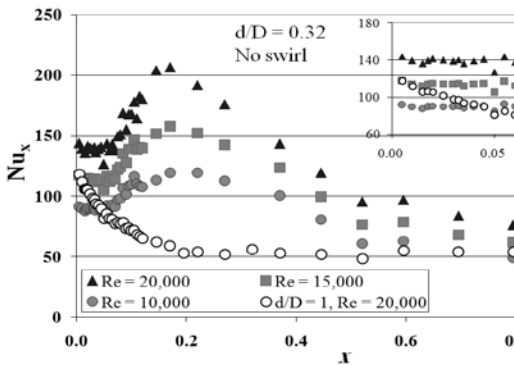

Fig. 6 Variation of  $Nu_x$  vs. pipe length  $X$ .

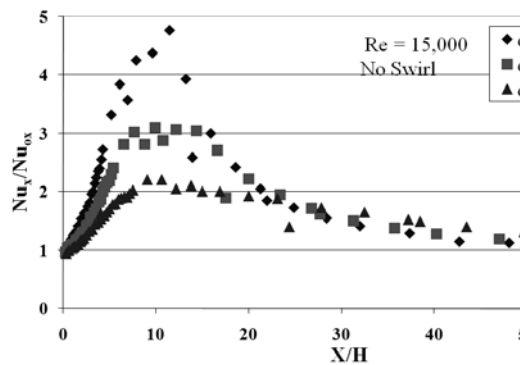

Fig. 7 Variation of  $Nu_x/Nu_{0x}$  vs.  $X/H$  with  $d/D$ .

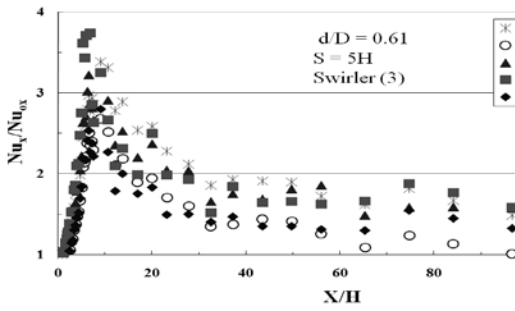

Fig. 8 Variation of  $Nu_x/Nu_{0x}$  vs.  $X/H$  with  $Re$ .

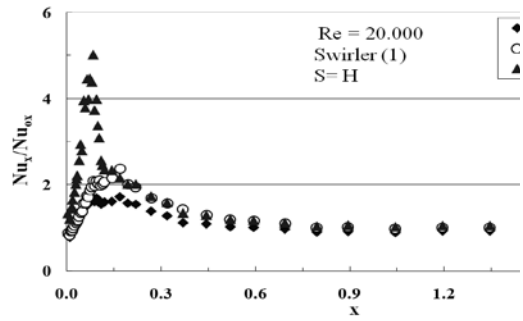

Fig. 9 Variation of  $Nu_x/Nu_{0x}$  vs.  $X$  with  $d/D$ .

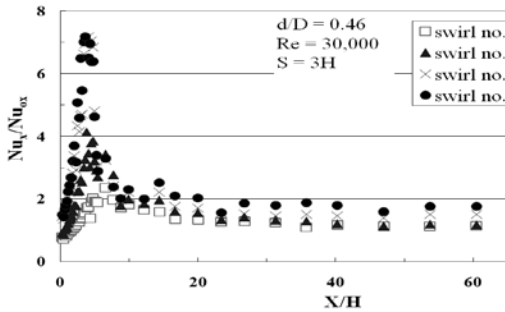

Fig. 10 Effect of vane angle on  $Nu_x/Nu_{0x}$  with  $X/H$ .

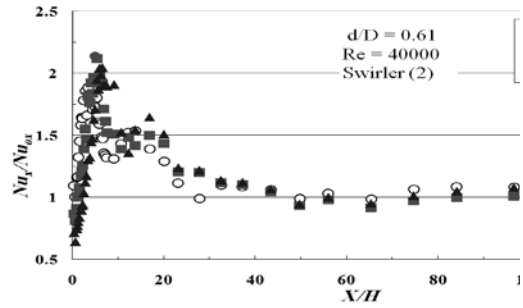

Fig. 11 Effect of swirler position on  $Nu_x/Nu_{0x}$ .

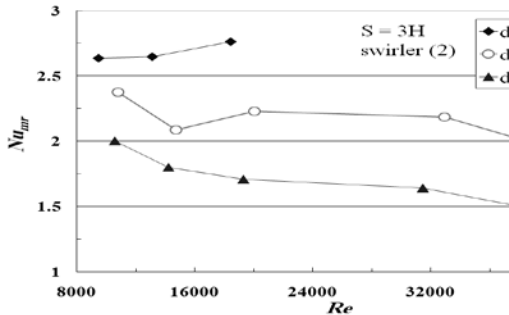

Fig. 12 Variation of  $Nu_{mr}$  with  $Re$ . for different value of  $d/D$

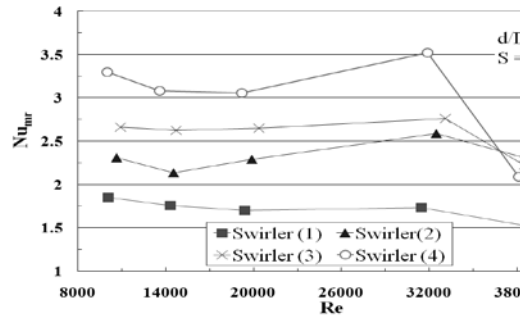

Fig. 13 Variation of  $Nu_{mr}$  with  $Re$ . for different swirlers

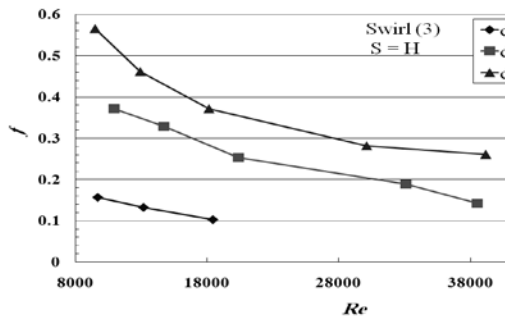

Fig. 14 Relation between  $f$  and  $Re$  for different ratio of  $d/D$ .

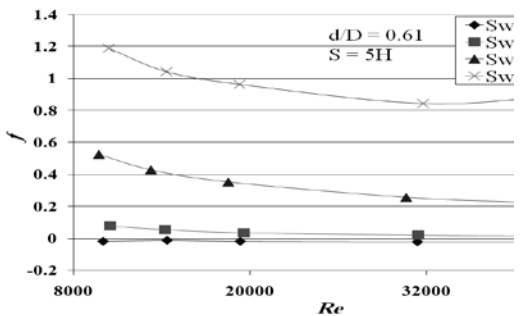

Fig. 15 Effect of  $Re$  on  $f$  for different swirlers.



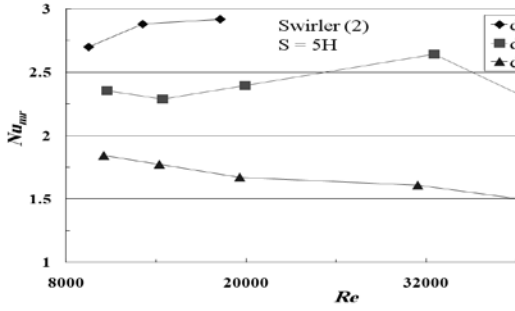

Fig. 16 Variation of  $Nu_{mr}$  vs.  $Re$  for swirler (2).

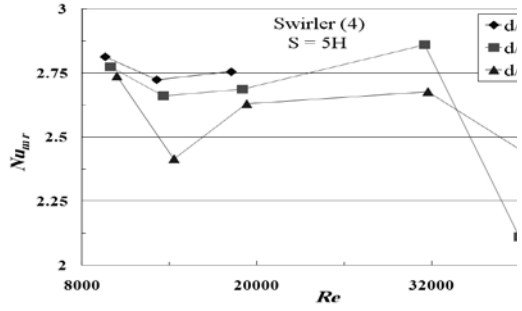

Fig. 17 Variation of  $Nu_{mr}$  vs.  $Re$  for swirler (4).

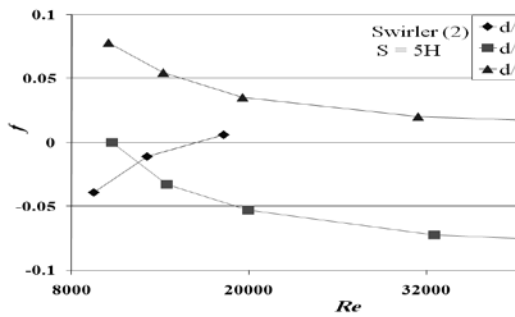

Fig. 18 Effect of  $Re$  on  $f$  with  $d/D$  for swirler (2).

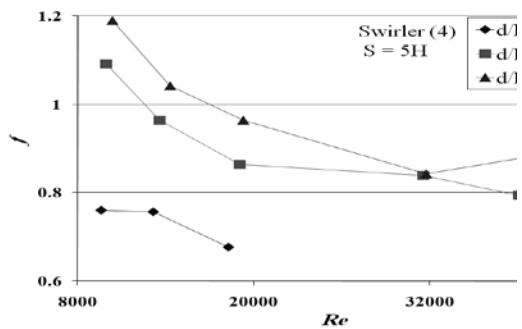

Fig. 19 Effect of  $Re$  on  $f$  with  $d/D$  for swirler (4).

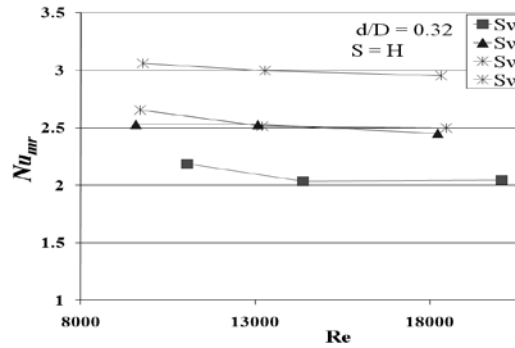

Fig. 20 Variation of  $Nu_{mr}$  vs.  $Re$  for  $d/D = 0.32$ .

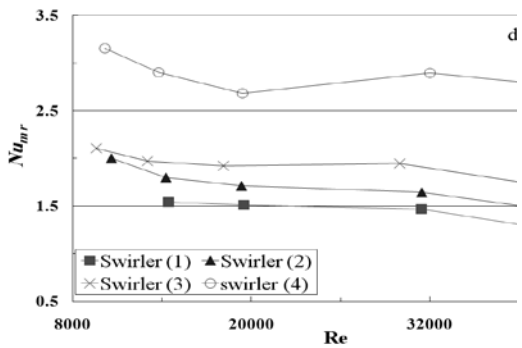

Fig. 21 Variation of  $Nu_{mr}$  vs.  $Re$  for  $d/D = 0.61$ .

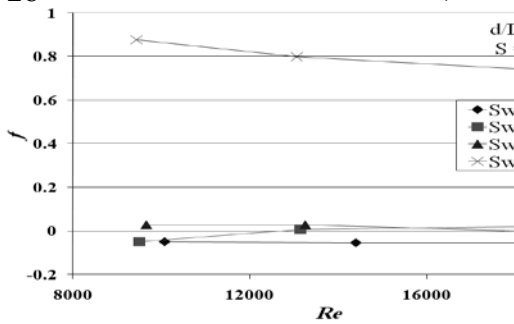

Fig. 22 Effect of swirler type on  $f$  for  $d/D = 0.32$ .

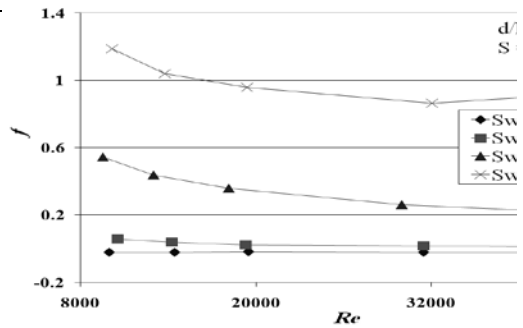

Fig. 23 Effect of swirler type on  $f$  for  $d/D = 0.61$ .

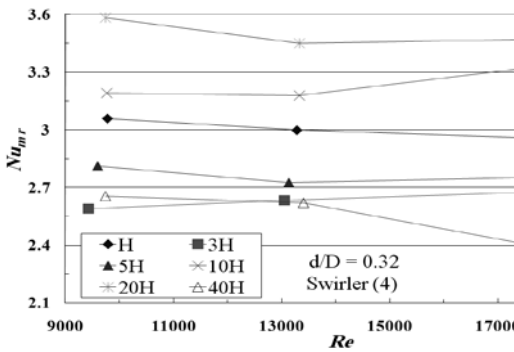

Fig. 24 Effect of swirler position on  $Nu_{mr}$  for  $d/D = 0.32$ .

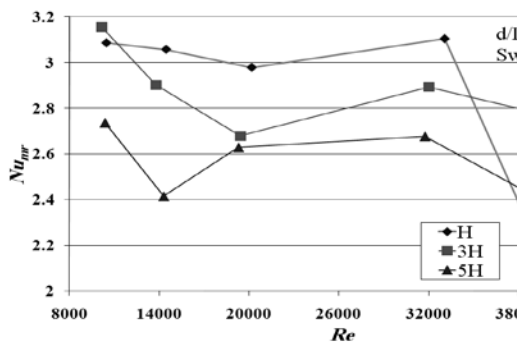

Fig. 25 Effect of swirler position on  $Nu_{mr}$  for  $d/D = 0.61$ .

### 4-3 Influence of Sudden Expansion Ratio

The effect of sudden expansion ratio on the heat transfer rate is presented in Figs. 16 and 17. The  $Nu_{mr}$  increases with increasing sudden expansion ratio (decreasing  $d/D$ ). That is due to; at the same  $Re$  as  $d/D$  decreases, the axial flow velocity at the downstream pipe increases. This causes the swirl generator to rotate at high speed and increases the swirling flow intensity and turbulence. Also the length of the recirculation zone increases with decreasing  $d/D$ . For these reasons the heat transfer rate increases with decreasing  $d/D$ . But as the vane angle increases the reattachment point move towards the inlet and the length of the recirculation zone decreases, and therefore the effect of  $d/D$  on heat transfer becomes insignificant with increasing vane angle. Figures 18 and 19 present the effect of  $d/D$  ratio on  $f$ . The figures show that as  $d/D$  decreases,  $f$  decreases too. This is because the area of the recirculation zone increases with decreasing  $d/D$ . The boundary layer is destroyed by the back flow encountered in the recirculation zone resulting in a decrease in the friction between the fluid and the tube wall.

### 4-4 Effect of Vane Angle

The influence of vane angle of swirl generator blades on heat transfer is represented in Figs. 20 and 21. The  $Nu_{mr}$  increases with increasing vane angle. This is because increasing blade angle leads to decreasing of the reattachment length. The decrease of

the recirculation zone causes shear rates and hence increases the turbulence kinetic energy causing higher heat transfer rates [29]. This enhancement is also promoted by increasing the tangential velocity component at nominally constant values of axial velocity. The effect of vane angles on heat transfer is higher at the high values of  $d/D$  as discussed earlier. This is due to the interference between the effect of decreasing  $d/D$  and increasing vane angle on the length of the recirculation region. The effect of increasing vane angle is higher at high  $d/D$  and decreases with  $d/D$  decreasing. The effect of the vane angle on  $f$  is presented in Figs. 22 and 23. Figures show that  $f$  increases with increasing  $\theta$ . This effect is due to the increase in the tangential velocity which increases the flow paths length and increases the contact between the fluid and tube surface which causes an increase in the friction factor.

**4-5 Effect of Swirl Generator Position**

Both enhancement and reduction can be observed with increasing the distance  $S$  (distance between test tube entrance and the swirl generator). At small vane angle,  $Nu_{mr}$  increases with increasing  $S$ . At high vane angle, as  $S$  increases  $Nu_{mr}$  decreases to a minimum value at  $S = 5H$ . Then  $Nu_{mr}$  increases with the distance  $S$  increasing to a peak value at  $S = 20H$ . After that with the distance  $S$  increasing,  $Nu_{mr}$  decreases. This is shown in Figs. 24–26. Swirl generator position also has an effect on  $f$  as shown in Figs. 27 and 28. Figures 27 and 28 show that as the swirl generator moves away from the entrance the friction factor decreases or increases depending on the sudden expansion ratio and the swirl generator vane angle.

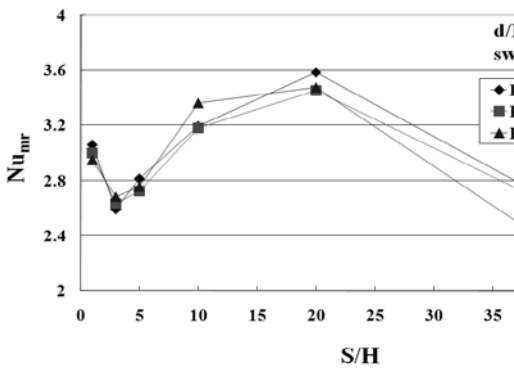

**Fig. 26** Effect of swirler position on  $Nu_{mr}$  for  $d/D = 0.32$ .

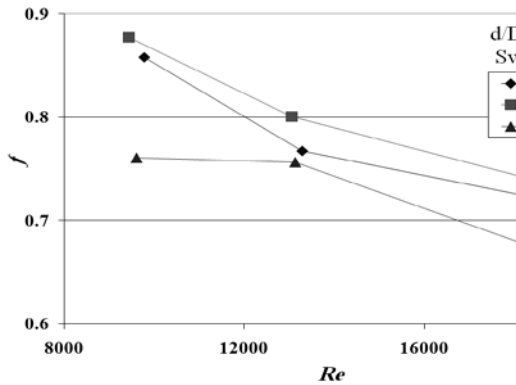

**Fig. 27** Effect of  $Re$  on  $f$  for  $d/D = 0.32$ .

## 4-6 Heat Transfer Enhancements Efficiency

It has been shown that using propeller swirl generator increases both the heat transfer rate and pressure drop. The enhancement efficiency is used to show whether, in terms of energy saving, inserting a swirl generator after a pipe sudden

expansion is effective or not. Enhancement efficiency is the heat transfer coefficients for swirling flow through sudden pipe expansion normalized by the corresponding fully developed heat transfer coefficient for the sudden expansion without swirl at constant pumping power.

Figures 29–34 show the effect of swirling flow through sudden expansion of a pipe on the enhancement efficiency. The figures show that the enhancement efficiency is generally greater than unity. This means that using of a propeller swirl generator after a sudden expansion of a pipe increases the efficiency. Figures also show that the enhancement efficiency decreased with increasing the Reynolds number. That is because as  $Re$  increases, the heat transfer coefficient for the swirling flow through sudden pipe expansion increases. This effect is due to the high swirl intensity imposed on the flow and to the decrease of the thermal boundary layer as a result of increasing the radial turbulent fluctuations. The heat transfer coefficient increase for the plain pipe is higher than that for swirling flow in sudden expansion. While the two coefficients increase with  $Re$ , the ratio of both values may decrease. Therefore, the swirling is more effective at low Reynolds numbers.

The effect of  $d/D$  value on the efficiency is shown in Figs. 29–30. As shown in figures, the maximum efficiency is obtained at the low value of  $d/D = 0.32$ . This means that the enhancement efficiency increases with decreasing  $d/D$ . This is because decreasing  $d/D$ , the heat transfer coefficient increases. Also the pressure drop decreases with decreasing  $d/D$  due to the increase of the recirculation zone and the decrease of the boundary layer. So the efficiency increases with the sudden expansion ratio increasing.

Figures 31 and 32 represent the effect of the swirl generator vane angle on the enhancement efficiency. Figures show that the efficiency increases with increasing the vane angle. This is because as the vane angle increases, the tangential velocity increases at nominally constant values of axial velocity. Increasing the tangential velocity induces high turbulence and destroys the boundary layer. Therefore, the heat transfer rate increases and the efficiency increases with increasing vane angle.

Figures 33 and 34 show the effect of different swirl generator position on the enhancement efficiency. At low vane angle, the efficiency increases by increasing the distance between the entrance and the swirl generator. On the other hand, at high vane angle, the efficiency increases with decreasing the distance. Different swirl generator position ( $S=10H$ ,  $20H$  and  $40H$ ) is tested at swirl generator vane angle  $60^\circ$  and  $d/D =$

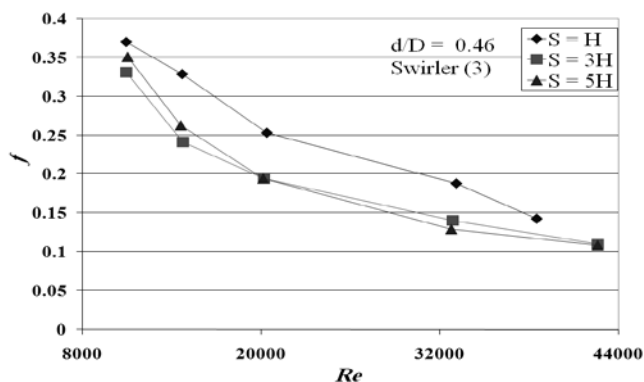

Fig. 28 Effect of  $Re$  on  $f$  for  $d/D = 0.46$ .

0.32. As shown in Fig. 33. The highest enhancement efficiency of 405% is obtained at  $S=20H$  and  $Re=9746$ .

### 4-7 Empirical Correlations for the Results

Correlations for the turbulent swirling flow with different values of vane angle to predict the relative Nusselt number, friction factor and enhancement efficiency were derived.

$$Nu_{mr} = -1.87 \times 10^{-10} Re^2 - 1.81(d/D)^{1.5} + 0.11(\tan \theta)^3 - 3.39 \times 10^{-2} / (\tan \theta)^2 + 14.21S^{2.5} + S^3 + 1.95 \quad (9)$$

$$f = -2.04 \times 10^{-8} Re^{1.5} - \frac{0.132}{(d/D)} + 3 \times 10^{-4} (\tan \theta)^2 - 0.406S + 0.146$$

$$\eta = -4.8 \times 10^{-10} Re^2 - 1.96(d/D)^{1.5} + 7.85 \times 10^{-2} (\tan \theta)^3 - \frac{3.51 \times 10^{-2}}{(\tan \theta)^2} + 20.878S^{2.5} + S^3 + 3.312 \quad (10), (11)$$

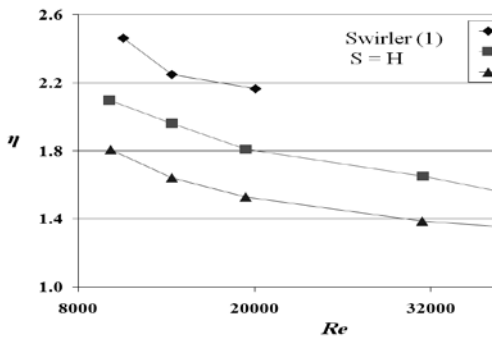

Fig. 29 Effect of  $Re$  on  $\eta$  for swirler (1).

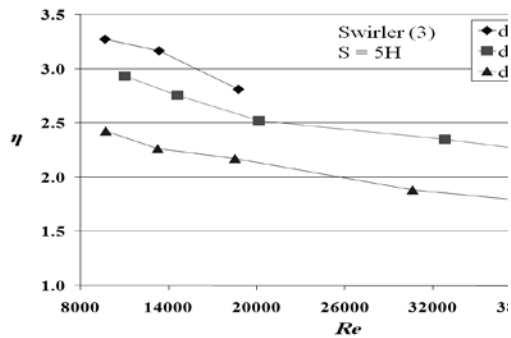

Fig. 30 Effect of  $Re$  on  $\eta$  for swirler (3).

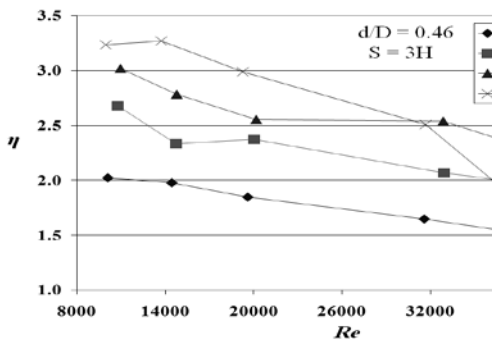

Fig. 31 Effect of  $Re$  on  $\eta$  for  $d/D = 0.46$ .

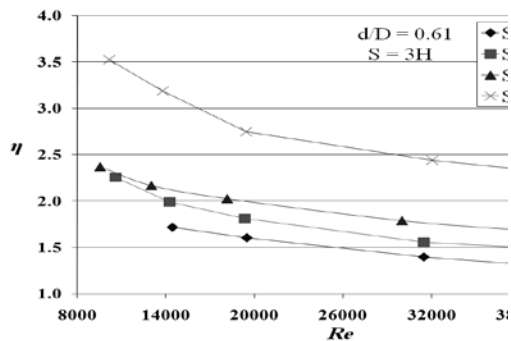

Fig. 32 Effect of  $Re$  on  $\eta$  for  $d/D = 0.61$ .

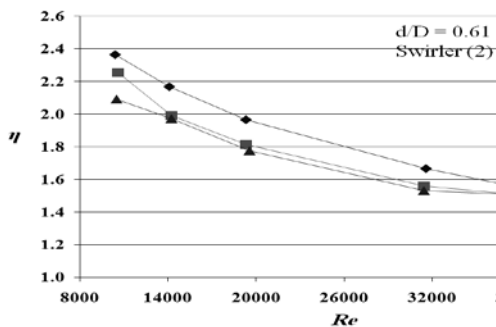

Fig. 33 Effect of  $Re$  on  $\eta$  with position for swirler (2).

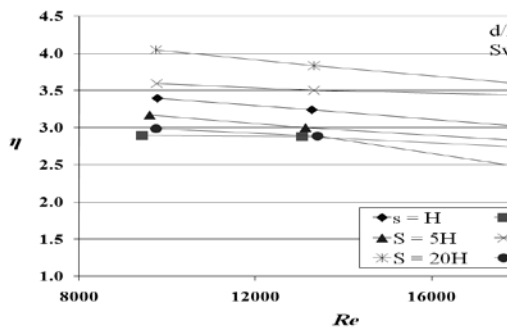

Fig. 34 Effect of  $Re$  on  $\eta$  with position for swirler (4).

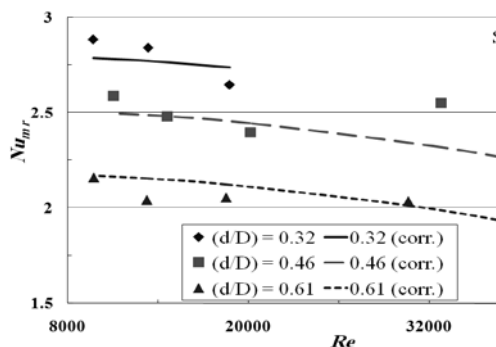

Fig. 35 Correlation of results of  $Nu_{mr}$  for swirler (3).

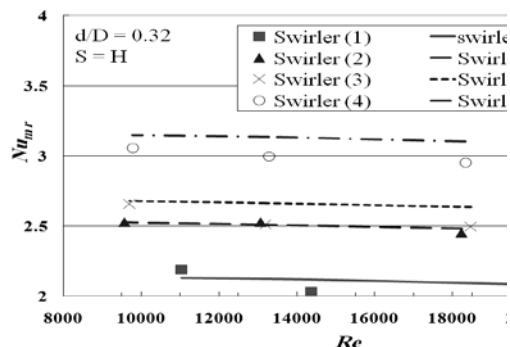

Fig. 36 Correlation of results of  $Nu_{mr}$  for  $d/D = 0.32$ .

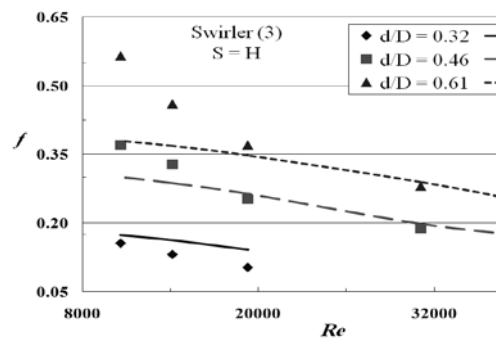

Fig. 37 Correlation of results of  $f$  for swirler (3).

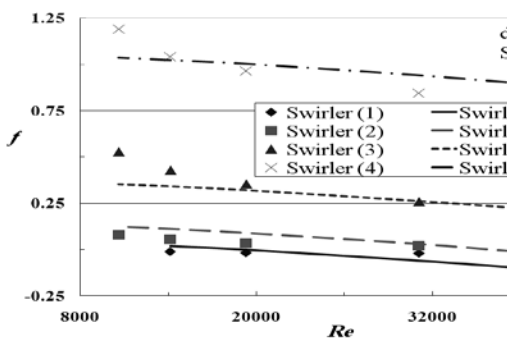
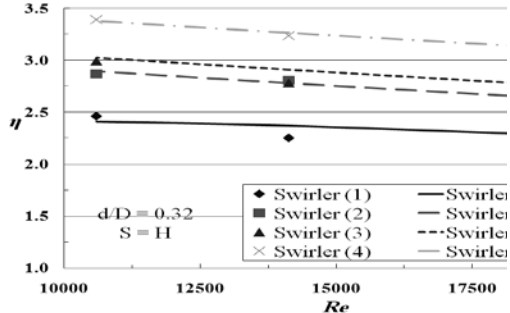
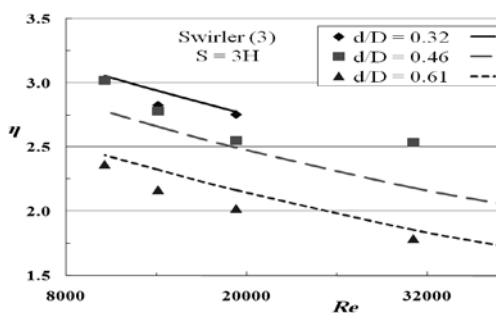

Fig. 38 Correlation of results of  $f$  for  $d/D = 0.61$ .



**Fig. 39** Correlation of results of  $\eta$  for swirler (3).    **Fig. 40** Correlation of results of  $\eta$  for  $d/D = 0.32$ .

The correlations are valid for  $d/D = 0.32$  to  $0.61$ ,  $\theta = 15^\circ$  to  $60^\circ$ ,  $S = H$  to  $5H$  (m) and  $Re = 9000$  to  $41000$  within r.m.s error 16.6%, 7.7% and 17.7% for  $Nu_{ms}$ ,  $f$  and  $\eta$ ; respectively. Figures 35–40 show comparison between the experimental result and the correlations, and a reasonable agreement was found as shown in that figures.

## 5. CONCLUSION

The present work is an experimental investigation of heat transfer and pressure drop characteristics of turbulent swirling air flow through an axisymmetric sudden expansion pipe. The examined  $Re = 9,000$  to  $40,000$ ,  $d/D = 0.32$ ,  $0.46$  and  $0.61$ , swirler vane angle  $\theta = 15^\circ$ ,  $30^\circ$ ,  $45^\circ$  and  $60^\circ$  and swirler position  $S = H$ ,  $3H$ ,  $5H$ ,  $10H$ ,  $20H$  and  $40H$ . Based on above study, the following conclusions are drawn:

1. As Reynolds number increases the peak local Nusselt number increases and move towards the inlet. The mean Nusselt number increases with Reynolds number increasing for flow with and without swirl, while Relative mean Nusselt number decreases with increasing Reynolds number.
2. As the sudden expansion ratio increases the relative mean Nusselt number increases while the friction factor decreases.
3. Both the relative mean Nusselt number and friction factor increase with increasing vane angle.
4. If the swirl generator is located near the pipe inlet (separation zone), a reduction in the heat transfer rate is observed. Moving the swirl generator away from the sudden expansion point causes a significant decrease in the relative mean Nusselt number and then it increase to a peak value at a position of about  $20H$ , and then it decreases after that.
5. Although the Nusselt number increases with the Reynolds number, the enhancement efficiency decreases by increasing the Reynolds number. The efficiency also increases with the increase of the sudden expansion ratio and the vane angle.
6. Empirical correlations are developed for Nusselt number, friction factor and enhancement efficiency. The predicted values are in reasonable agreement with the experimental results.

## 6. REFERENCES

1. Akpınar, E.K., Y. Bicer, C. Yildiz and D. Pehlivan, "Heat Transfer Enhancements in A Concentric Double Pipe Exchanger Equipped With Swirl Elements", Int. Commun. Heat Mass Transfer, 31 (6) (2004) 857–868.
2. Akpınar, E.K. and Y. Bicer, "Investigation of Heat Transfer and Exergy Loss in A Concentric Double Pipe Exchanger Equipped With Swirl Generator", Int. J. of Thermal Sciences 44 (2005) 598–607.
3. Çakmak, G. and C. Yıldız, "The Influence of the Injectors with Swirling Flow Generating on the Heat Transfer in the Concentric Heat Exchanger", Int. Commun. in Heat and Mass Transfer 34 (2007) 728-739.



4. Promvonge, P. and S. Eiamsa-ard, "Heat Transfer Enhancement in a Tube with Combined Conical-Nozzle Inserts and Swirl Generator", Energy Conversion and Management 47 (2006) 2867–2882.
5. Promvonge, P. and S. Eiamsa-ard, "Heat Transfer in a Circular Tube Fitted with Free-Spacing Snail Entry and Conical-Nozzle Turbulators", Int. Commun. in Heat and Mass Transfer 34 (2007) 838–848.
6. Promvonge, P., "Thermal Enhancement in a Round Tube with Snail Entry and Coiled-Wire Inserts", Int. Commun. in Heat and Mass Transfer 35 (2008) 623–629.
7. Zahaby, A.M., M.K. Bassiouny, A. Khalil, E.A. El-Shenawy and A.S. Abdullah, "Effects of Surface Ejection or Injection at Different Angles on The Flow Field and Heat Transfer in a Rectangular Channel", Proceedings of the 6<sup>th</sup> International Engineering Conference, Mansoura – Sharm El-Sheikh, Volume 2, March 18-23, 2008, pp 242–260.
8. Zahaby, A.M., M.K. Bassiouny, E.A. El-Shenawy, A. Khalil and A.S. Abdullah, "Experimental Studies of the Heat Transfer and Friction Coefficient in a Channel with Surface Injection", Proceedings of the 6<sup>th</sup> International Engineering Conference, Mansoura – Sharm El-Sheikh, Volume 2, March 18-23, 2008, pp 226–241.
9. Saha, S.K. and A. Dutta, "Thermohydraulic Study of Laminar Swirl Flow through a Circular Tube Fitted with Twisted Tapes", J. Heat Transfer 123 (3) (2001) 417–427.
10. Saha, S.K., A. Dutta and S.K. Dhal, "Friction and Heat Transfer Characteristics of Laminar Swirl Flow through a Circular Tube Fitted with Regularly Spaced Twisted Tape Elements", Int. J. Heat and Mass Transfer 44 (2001) 4211–4223.
11. Hong, S.W. and A.E. Bergles, "Augmentation of Laminar Flow Heat Transfer in Tubes by Means of Twisted-Tape Inserts", ASME J. Heat Transfer 98, (1976) 251–256.
12. Yildiz, C., Y. Bicer and D. Pehlivan, "Effect of Twisted Strips on Heat Transfer and Pressure Drop in Heat Exchangers", Energy Convers. Management 39 (3/4) (1998) 331–336.
13. Chang, S. W., T. L. Yang and J. S. Liou, "Heat Transfer and Pressure Drop in Tube with Broken Twisted Tape Insert", Experimental Thermal and Fluid Science 32 (2007) 489–501.
14. Gül, H. and D. Evin, "Heat Transfer Enhancement in Circular Tubes Using Helical Swirl Generator Insert at The Entrance", Int. J. of Thermal Sciences 46 (2007) 1297–1303.
15. Bali, T., "Modeling of Heat Transfer and Fluid Flow for Decaying Swirl Flow in a Circular Pipe", Int. Commun. Heat and Mass Transfer 25 (3) (1998) 349–358.
16. Bali, T. and T. Ayhan, "Experimental Investigation of Propeller Type Swirl Generator for a Circular Pipe Flow", Int. Commun. Heat and Mass Transfer 26 (1), (1999) 13–22.
17. Zaherzadeh, N.H. and B.S. Jagadisht, "Heat Transfer in Decaying Swirl Flows", Int. J. Heat and Mass Transfer. Vol. 18, (1975) 941–944.
18. Saraç, B.A. and T. Bali, "An Experimental Study on Heat Transfer and Pressure Drop Characteristics of Decaying Swirl Flow through a Circular Pipe with a Vortex Generator", Experimental Thermal and Fluid Science 32 (2007) 158–165.

19. Mostafa, A.A., "*Effect of Swirl Angle and Geometry on Heat Transfer in Turbulent Pipe Flow*", M.Sc. Thesis, Faculty of Engineering, Cairo University (1980).
20. Mostafa, G.M., "*Effect of Swirling Angle and Swirler Number on Heat Transfer and Pressure Drop in Turbulent Tube Flow*", M.Sc. Thesis, Faculty of Engineering, Cairo University (1987).
21. Durmus, A., İ. Kurtbaşı, F. Gülçimen and E. Turgut, "*Investigation of the Effect of Co Axis Free Rotating Propeller Type Turbulators on the Performance of Heat Exchanger*", Int. Commun. Heat and Mass Transfer 31 (2004) 133–142.
22. Kurtbaşı, İ., A. Durmuş, H. Eren and E. Turgut, "*Effect of Propeller Type Swirl Generators on the Entropy Generation and Efficiency of Heat Exchangers*", Int. J. Thermal Science 46 (2007) 300–307.
23. Eiamsa-ard, S., S. Rattanawong and P.T. Promvonge, "*Turbulent Convection in Round Tube Equipped with Propeller Type Swirl Generators*", Int. Commun. Heat and Mass Transfer 36 (2009) 357–364.
24. Vanierschot, M. and E. Van den Bulck, "*The Influence of Swirl on the Reattachment Length in an Abrupt Axisymmetric Expansion*", Int. J. of Heat and Fluid Flow 29 (2008) 75–82.
25. Dellenback, P.A., D.E. Metzger and G.P. Neitzel, "*Heat Transfer to Turbulent Swirling Flow through a Sudden Axisymmetric Expansion*", J. of Heat Transfer Vol. 109 (1987) 613-620.
26. Dellenback, P.A., D.E. Metzger and G.P. Neitzel, "*Measurement in Turbulent Swirling Flow through an Abrupt Axisymmetric Expansion*", American Institute of Aeronautics and Astronautics, 26 (6), (1988), 669–681.
27. White, F.B., "*Fluid Mechanics*", McGraw-Hill Company, (1979), New York.
28. Holman, J.P., "*Experimental Method for Engineers*", 4<sup>th</sup> Editions, McGraw-Hill Book Company, (1984), New York.
29. Mostafa, A.A. "*Effect of Swirl Angle and Geometry on Heat Transfer in Turbulent Pipe Flow*" M.Sc. Thesis, Faculty of Engineering Cairo University (1980).
30. Baughn, J.W., M.A. Hoffman, B. E. Launder, D. Lee and C. Yap, "*Heat transfer, temperature, and velocity measurements downstream of abrupt expansion tube at a uniform wall temperature*", ASME J. of Heat Transfer 111(1989), 870-876.

## دراسة عملية لانتقال الحرارة والاحتكاك للسريان الدوامي المضطرب للهواء خلال التمدد المفاجئ للمواسير

أ.م.د./السعيد خليل\* و أ.م.د./علاء الدين زهير\*\* و م/أيمن محمد فريد\*\*

\*قسم هندسة القوى الميكانيكية، كلية الهندسة جامعة طنطا ، طنطا

\*\* قسم الهندسة الميكانيكية ، معهد التبين للدراسات المعدنية ، القاهرة

دراسة عملية لخصائص كلا من انتقال الحرارة والفقء في الضغط للسريان الدوامي المضطرب للهواء خلال التمدد المفاجئ للمواسير مع اختلاف زاوية الريشة ونسبه التمدد المفاجئ. تم دراسة كلا من نسبة التمدد ومعامل رينولدز وزاوية الريشة وموضع مولد الدوامات علي كلا من انتقال الحرارة و الفقء في الضغط. تم تسخين الماسورة بفيض حراري ثابت و رقم رينولدز يتراوح من 9000 الي 41000. يتضح من النتائج أن دخول مولد الدوامات علي أنابيب التمدد المفاجئ قد تسبب في زيادة كلا من رقم نوسلت النسبي والكفاءة للجزء المختبر. الكفاءة تزداد كلما انخفض رقم رينولدز بينما تزداد بزيادة نسبة التمدد المفاجئ وزاوية الريشة. وكانت اعلي كفاءة تم الحصول عليها هي 405%. تم استنتاج معادلات لحساب رقم نوسلت و الفقء في الضغط والكفاءة. كما تم تقييم الأداء الحراري لمعرفة مقدار الفائدة من استخدام مولدات الدوامات.