

Journal of Soil Sciences and Agricultural Engineering

Journal homepage: www.jssae.mans.edu.eg
Available online at: www.jssae.journals.ekb.eg

Modification of Pesticide Sprayer to Suit the Orchard Trees

Shaban, Y. A.; H. M. El-Ghobashy* ; M. A. Aboegela and S. A. Marey

Agricultural Engineering Research Institute, Agriculture Research Center, Dokki, Giza, Egypt.



Cross Mark

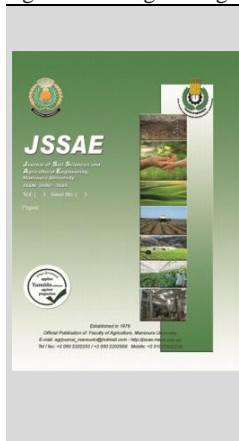

ABSTRACT

This study aims to develop a commonly used sprayer in the Egyptian farms (gun sprayer, Alcon Motori) adapted for orchard fields. The main aspect of the modified sprayer was the ability to move nozzles at vertical reciprocating motion NVRM which improves the deposition of the pesticide on upper and lower leaf surfaces. The modified sprayer included the following parts: nozzle carrier frame, pesticide tank, pump, pressure regulator, pressure gauge and hoses. The modified sprayer was evaluated under three different forward speeds "FS" of 2.4, 3.4, and 4.6 km/h, three nozzle reciprocating displacement "NRD" of 250, 400, and 600 mm, and three values of operating pressure "OP" of 1000, 1500, and 2000 kPa on the number of droplets deposition at the upper and lower leaf surface, the droplet mean diameter, application rate, machine field capacity, and spraying cost. Results revealed that increasing the forward speed caused decreasing the number of droplet; droplet mean diameter, application rate, spraying cost, and increasing the sprayer field capacity. The droplet density and droplet mean diameter were inversely proportional to the nozzle reciprocating displacement. The operating pressure at 2000 kPa resulted in the highest droplet density and the lowest droplet mean diameter at different forward speeds and nozzles reciprocating displacement.

Keywords: sprayer machine; pesticide; nozzle; droplet density; orchard trees

INTRODUCTION

Pomegranate (*Punica granatum* L., Punicaceae) is one of the most ancient world's edible fruits. The pomegranate, which is native in Iran, was introduced in Egypt by the mid second millennium BC (Hussein and Gouda, 2018). The total cultivated area in Egypt is 241000 ha with an average productivity of 19.35 G gm ha⁻¹ (Abdel-salam *et al.*, 2018). In addition to the enormous pests and fungal diseases that infect the pomegranate plantations in Egypt, there is also the foliar spray of the fertilizations. Consequently, a huge amount of insecticides, fungicides, fertilizations and hormones are used. Continuous improvement of pesticide use techniques is needed to prevent pollution associated with drift and sedimentation during the application of pesticides in orchards. Minimize the pesticide and/or foliar fertilization use is one of the main objectives of the policy actions related to agriculture sustainability (Cross, 1991). This objective can be reached through the implementation of different and complementary approaches. A most important contribution can achieve through technological improvements in the equipment use to carry out the protection treatments (Emanuele *et al.*, 2018). This can play an essential role in allowing improvement capability of pesticide deposition on the plant leaves. In this respect, a wide range of sprayer machine types is used. Tractor-driven air blast sprayers are the most commonly equipment for pesticide application in orchards which are use an air jet to project spray into the tree canopy.

The plume of pesticide spray produced by a sprayer often does not completely match the tree canopy geometry (Cross, 1991). This can cause a physical movement of pesticide droplets through the air from the target site (the orchard) towards any non-target sites like adjacent vegetation, other crops, water bodies and residential areas (Matthews, 2000). There are some factors that affect the sprayer's efficiency. These

include equipment design, application parameters, type of formulation and meteorological conditions (Salyani and Cromwell, 1992; Ganzelmeier 1993; Ganzelmeier *et al.*, 1992).

Operating pressure considered one of the most important parameters that affect the spraying uniformity (He *et al.*, 2013). Increasing the nozzle pressure tends to increase the droplet density and number of small size droplets with better uniformity distribution (Sehsah and Kleisinger 2009, Dahab and Eltahir, 2010 and Suber *et al.*, 2017) However, increasing the pressure does not confirm constant uniformity of the spray distribution for some types of nozzles (Višacki *et al.*, 2016 and Padhee *et al* 2019).

Information about optimum sprayer speed is important in view of spraying economics as well as its potential effect on drift reduction (Triloff 2005)..., in orchards; different interactions are expected between travel speed and drift. According to most literature claims, drift in orchards decreases with an increase in sprayer travel speed (Sehsah, 2007 and Triloff, 2011). Air blast sprayers are the most common methods of applying pesticide to fruit trees. These units consist of a fan that is capable of producing a high volume of airflow into which the spray is deposited. Possibilities for adapting the characteristics of sprayer air flow to different tree canopies are quite limited.

Therefore, the main objective of this study is to modify the pesticide sprayer (Alcon sprayer) widely used in the Egyptian farm into a movable sprayer for spraying pesticides in two opposite rows of trees in orchard fields

MATERIALS AND METHODS

The modified sprayer Fig. (1, a) works with nozzle moves in a vertically reciprocating motion (up and down) to improve the deposition of pesticides on both upper and lower leaf surfaces. The development process was carried out in a local private workshop at Behera Governorate, Egypt. The field experiments were executed at a commercial pomegranate

* Corresponding author.

E-mail address: drhossamelghobashy@gmail.com

DOI: 10.21608/jssae.2021.171502

orchard during the 2019 season. A schematic diagram of the developed sprayers is depicted in Fig. (1, b). The main components of the developed sprayer were as follow:

Nozzle hold frame

A steel frame consisting of two vertical arms was manufactured and fixed behind the sprayer tank. Four nozzles were fixed on each arm with nozzles span of 50 cm. A copper sprinkler with double outlet and anti-drip were identified. A ceramic nozzle of 1.8 mm orifice was installed in the sprinkler.

The frame was fabricated from U section steel of 40 × 70 × 2mm with net dimensions of 230 × 180 length and width with maximum height of 250 cm from wheel surface. A sliding crank mechanism was also fabricated to provide the

reciprocating motion. The reciprocating unit consists of two main parts. The first include a circular disk of 350 mm diameter, 20 mm thickness and has three holes used for setting and adjust the appropriate displacement of 250, 400, and 600 mm. The source of rotational speed for this disk was a pulley fixed on a shaft connected to propeller shaft. The second part consists of a belt connecting the nozzles to circular disk through a pulley fixed on the frame to convert the rotational motion of the circular disk into a reciprocating motion of the nozzle carrier. The other end of the belt is connected to a spiral spring to maintain a proper tension during operation. Each nozzle was attached to a free-moving shaft on two ball bearing seats fixed to the main frame.

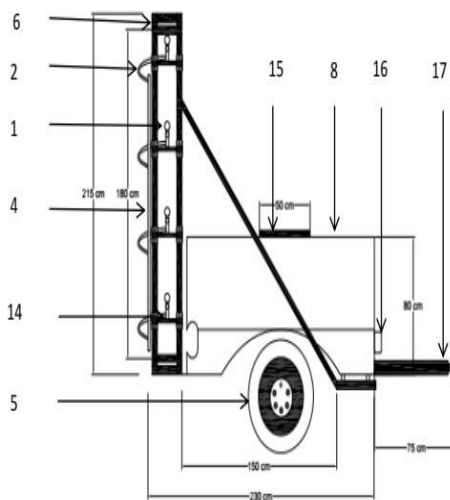
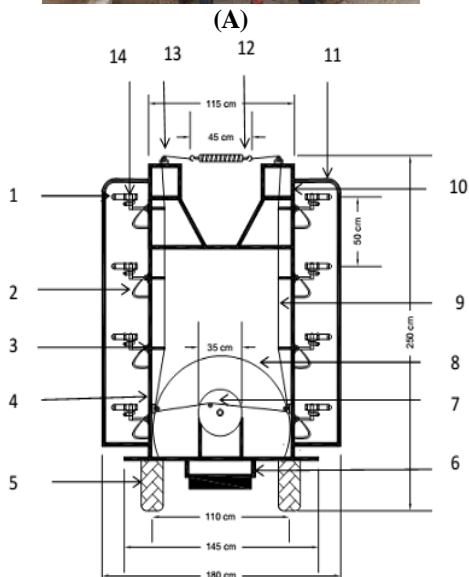

(B)Dim: cm Elevation

side view

Item	Name	Item	Name	Item	Name
1	Nozzle	7	Rocking cam	13	Roller
2	Hose connecting	8	Spray tank	14	Nozzle
3	Ball bear rocking	9	String rocking	15	Filling slot
4	Connecting pipe	10	Stand holder	16	Shaft
5	Wheel	11	Protection frame	17	Hitch point
6	Frame	12	Spring		

Fig. 1. The modified sprayer: (a) a photograph of the sprayer and (b) a schematic diagram of the sprayer.

Sprayer tank

A 600 liters corrosion-resistant fiberglass tank was used to store the spray liquid, and it has an opening to allow easy filling as well as a drain hole for easy cleaning.

Pump

A piston pump (model; DELTA 75TS2C) was fixed at the front of the tank. The specifications of this pump are

79 lit/min discharges at 540 rpm, the pressure range is 0.0 to 580 psi (4000kPa) and the maximum power is 6.0 kW. The pump was operated using PTO of the tractor

Pressure regulator and pressure gauge

A pressure regulator was used to maintain the operating pressure at a constant pressure during the operation. While the pressure gauge was used as indicator for the operating pressure

Performance evaluation

Evaluation of the sprayer was investigated under three forward speeds “FS” of 2.4, 3.4 and 4.6 km/h, three values of operating pressure “OP” of 1000, 1500 and 2000 kPa and three different nozzle reciprocating displacement “NRD” of 250, 400 and 600 mm. A Kubota tractor (model L2201, diesel engine of 16.7 kW at 2800 rpm) was used to operate the modified sprayer. The criteria of the performance evaluation included number of droplets on upper and lower tree leaves surface, droplet size, droplet surface mean diameter, field capacity. The number of droplets on the upper and lower leaf surface was determined using a computer and a conventional microscope (S&ST series of wide field microscope) to count the number of droplets on water sensitive cards placed on both leaf. Micrometry slit was used to measure the longitudinal and lateral diameters of the spray droplets. Then the droplet surface mean diameter (DSM, μm) was calculated using the equation (1):

$$DSM = \frac{DX + DY}{2} \dots\dots\dots (1)$$

Where:

DX : the longest droplet span in the longitudinal direction (μm)

DY : the longest droplet span in the lateral direction (μm).

The actual field capacity (AFC, ha (fed)/h) was determined by estimating the time consumed for the real work (T₁) per unit area and time lost for other activities such as turning, tank filling, etc. (T₂). Hence, actual field capacity was calculated using equation (2). While, the application rate (PR, lit/fed) of the sprayer was calculated using equation (3):

$$AFC = \frac{A}{T_1 + T_2} \dots\dots\dots (2)$$

$$PR = \frac{252 \times n \times q}{w \times v} \dots\dots\dots (3)$$

Where n is the number of nozzles, q is the flow rate of one nozzle (lit/min), w is the distance between two tree rows (m) and v is the forward speed (km/h).

The cost of spraying process in terms of EGP/h was determined considering fixed cost and variable cost under assuming:

A machine life expectancy of ten years with 500 and 1000 operating hour per year for the sprayer and tractor, respectively.

An interest rate of 10% and a machine salvage value of 10% of the machine price of EGP 25,000 and EGP 60,000, for the sprayer and tractor respectively.

The operation cost included the cost of labor, fuel consumption, and repair and maintenance. The labor (driver) cost was estimated at EGP 100/day (8 h/day)

The depreciation cost (D, EGP/h) was estimated using equation (4), (Hunt, 1983):

$$D = \frac{C - S}{L \times h} \dots\dots\dots (4)$$

Where, C is the cost of machine, S is the salvage value, L is the machine life and h is operating hour per year.

The interest (I, EGP/h) cost was estimated using equation (5) (hunt et al 1983):

$$I = \frac{(C+S) \times i}{2 \times h} \dots\dots\dots (5)$$

Where, i is the interest rate.

The housing, insurance and taxes were calculated considering 10% of the initial cost divided by the yearly operating hours. Meteorological conditions (i.e. wind speed, wind direction and temperature) during the field experiments were recorded. Wind speed and wind direction were measured with a hot wire anemometer (every 10 seconds), 0.5 m above

tree crowns. The wind speed was in a range of 1.74 – 3.2 m/s, and the temperature ranged between 24 and 30 °C. The experiments were arranged in a factorial design with three replicates using COSTST 6400 software. The analysis of variance has been done to investigate the significance of considered variables at significant level of 5%

RESULTS AND DISCUSSION

Droplets density

Impact of different operation variables on depositing droplets is shown in Fig 2. Apparently, increasing the “FS” significantly decreased the number of droplets on upper and lower leaf surfaces, which is logical by the decrease in the application rate. It is also obvious that the depositing droplets on either leaf surfaces were inversely proportional to the “NRD” at all values of the “FS” and “OP” (Fig. 2). For instance, the average number of droplets increased from 31.33 to 43.22 droplets/cm² and from 16.11 to 29.22 droplets/cm² on the upper and lower surface, respectively when the “NRD” decreased from 600 mm to 250 mm. This was attributed to increase the number of reciprocating with the short displacement accordingly, increase the number of droplets on both surfaces. On the other hand, increasing the “OP” caused an increase in the number of droplets on both surfaces at all levels of “NRD” and “FS” included in the study. An increase in the average of number of droplets/cm² from 35.77 to 40.22 on the upper leaf surface and from 20.44 to 23.77 on the lower leaf surface was observed when the “OP” increased from 1000 to 2000 kPa. These findings are in agreements with that obtained by Sehseh and Kleisinger, (2009), Dahab and Eltahir, (2010) and Suber, et al. (2017).

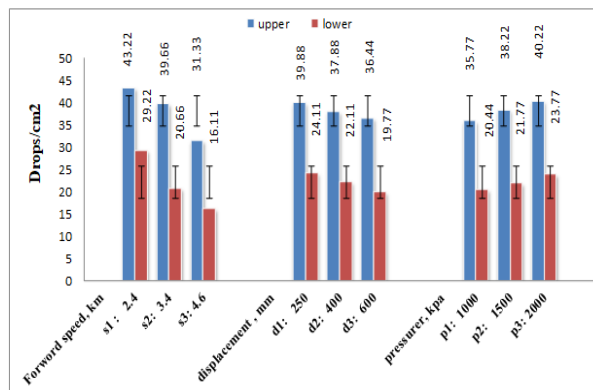

Fig. 2. Number of droplets on the upper and lower leaf surfaces at different levels of forward speed, nozzle reciprocating displacement and operating pressure Droplet surface mean diameter.

The effect of the “FS” and “NRD” under different “OP” levels on the droplet mean diameter is presented in Fig.3. The results indicated that a significantly increase in the droplet mean diameter was observed when the “FS” decreased at different levels of “NRD” and “OP” considered in this study. This result may be due to droplet fragmentation by increasing the “FS” as a result of increasing the resistance of the droplets to the air. These results are in agreement with that reported by Tayle et al (2009). Also, Fig.3. showed that the “NRD” at 250 mm increased the droplet mean diameter at all “FS” and “OP” levels. Increasing the “NRD” from 250 mm to 600mm increased the droplet surface mean diameter by 8.75 % at “FS” of 2.4 km/h and “OP” of 1000 kPa. This may be due to adding the same amount of liquid in smaller canopy area when use the short reciprocating displacement than that in case of the tall displacement. It can be concluded that the highest values of droplet mean diameter

recorded with the “OP” of 1000 kPa at all other parameters. On the other hand, the lowest values of droplet mean diameter associated with the “OP” of 2000 kPa at different levels of “FS” and “NRD”. This may attribute to increase the fragmentation action as a result of increasing the liquid pressure which is causing a decrease of the droplet diameter.

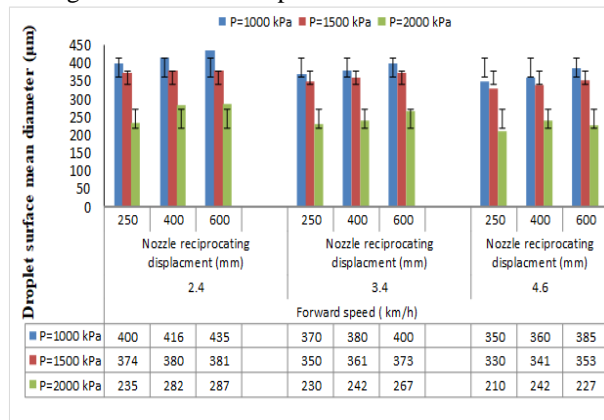

Fig. 3. Droplet surface mean diameter at different levels of forward speed, nozzle reciprocating displacement and operating pressure

Spraying application rate.

The effect of “FS” and “NRD” under different “OP” is shown in Fig.4. The spraying application rate significantly increased by decreasing the machine speed at all other “OP” and “NRD” levels. The application rate decreased by 52 % when the machine speed increased from 2.4 to 4.6 km/h at the “OP” of 1500 kPa and “NRD” of 600 mm. The other pressure and “NRD” levels had the same mentioned trend. This was attributed to increase of the machine actual field capacity by increasing the “FS” while the amount of pesticide is mostly constant. The 2000 kPa “OP” induced higher application rate values than other pressure levels. The application rate of 223.5, 256.38 and 295.82 lit/fed was observed with the pressure of 1000, 1500, 2000 kPa, respectively at “FS” of 4. 6 km/h and displacement of 600 mm. from figure 4; it can also be observing that the “NRD” has no effect on the application rate.

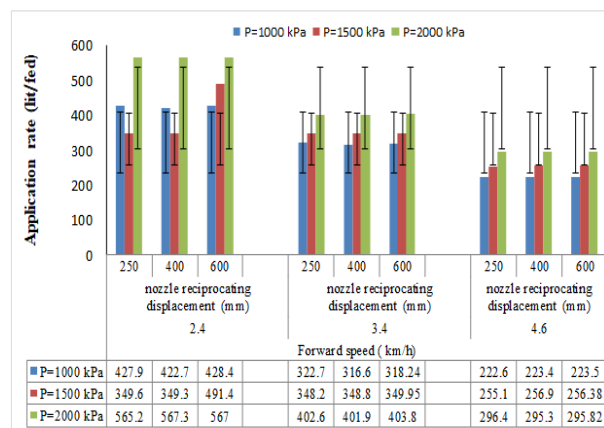

Fig. 4. spraying application rate at different levels of forward speed, nozzle reciprocating displacement and operating pressure

Machine actual field capacity.

The impact of “FS” and “OP” on the actual field capacity is shown in Fig 5. It is obvious that the increase in the machine speed caused a significant increase in the actual field capacity. Increasing the machine “FS” from 2.4 to 4.6 km/h increased the machine actualfield capacity from 1.87 fed/h to

3.32 fed/h at “OP” of 1500 kPa. The “OP” hadaninsignificant impact on the machine actualfield capacity. Increasing the “OP” tends to increase the sprayer field capacity at “FS”. This may be due to the slight increase in the “FS” when increasing the engine RPM to meet the required “OP”.

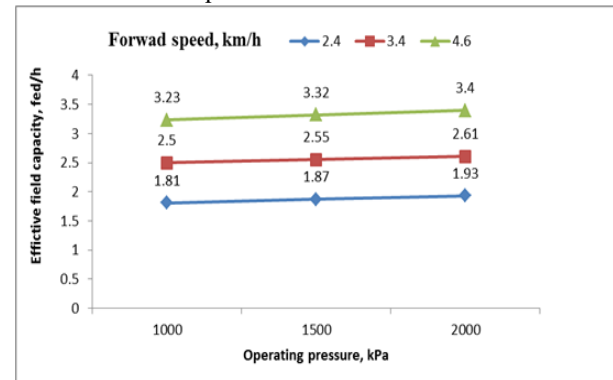

Fig. 5. Field capacity at different levels of forward speed, and operating pressure.

Cost analysis.

The cost of spraying process when using the developed sprayer was calculated as follow:

The annual depreciation of sprayer and tractor was calculated at EGP 4.5/h and EGP 5.4/ h, respectively. The interest cost was calculated at EGP 2.75/h and EGP 3.3/h for the sprayer and tractor, respectively. The remaining three elements of fixed costs (insurance, taxes, and housing) were calculated at EGP 1.5/ h and EGP 1.8/h for the sprayer and tractor, respectively. The total fixed cost was EGP 18.95/h. Hence the labor cost was calculated at EGP 12.5 /h. The mean value of fuel consumption was 2.5 lit/h and prevailing diesel price was EGP 6.75/lit Therefore, the fuel cost for the tractor was determined to be EGP 16.87/h. However, the cost of repair and maintenance was estimated at 2% of the machine cost /100 hours of operation (Hunt, 1983), which was calculated at EGP 5/h and EGP 12/h for the sprayer and tractor, respectively. Therefore, the operation cost was EGP 33.87/h The total spraying cost was EGP 52.82/h.

The values of spraying cost (EGP/ fed) under the parameter considered in this study are presented in fig. 6. The maximum cost of EGP 31.10/fed was observed at “FS” of 2.4 km/h, “NRD” of 400 mm and “OP” of 1000 kPa. On the other hand, the lowest values of spraying cost (EGP 14.4/fed) were associated with the “FS” of 2.4 km/h and “OP” of 2000 kPa.

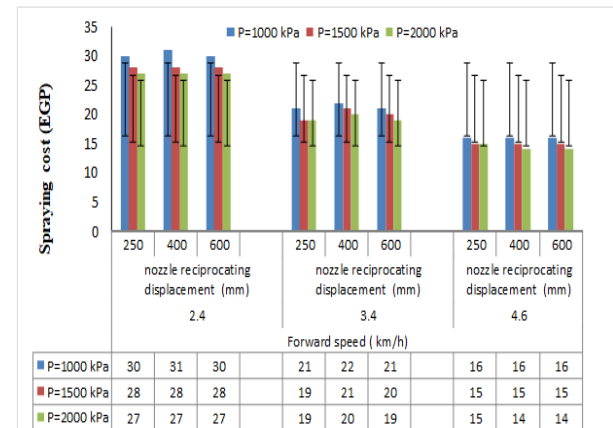

Fig. 6. Spraying cost at different levels of forward speed, nozzle reciprocating displacement and operating pressure.

CONCLUSION

A traditional commonly used sprayer in the Egyptian farms (gun sprayer, Alcon Motori) was developed to carry out the spraying process on the orchard fields while it trailed behind the tractor. The performance of the developed sprayer was evaluated at different spraying speeds, "NRD" and of the "OP". The specific conclusions of the study include the following:

1. The increase of the "FS" decreased the droplets density (number of droplets per square centimeter), droplet surface mean diameter, application rate, spraying costs. However, it caused an in actual field capacity.
2. The droplet density on both leaf surfaces and the droplet surface mean diameter were inversely proportional to the reciprocating displacement of the nozzles at all values of the "FS" and "OP". On the other hand, it has no effect on the application rate and field capacity.
3. Increasing the "OP" resulted in an increase of the droplets density, application rate and a decrease of the droplet surface mean diameter.

REFERENCES

- Abdel-salam . F. F., Moharram, Y.G., Esmat, M. El-Zalaki (2018). Physical Properties and Some Bioactive Compounds of Four Pomegranate Cultivars (*Punica granatum L.*) Grown in Egypt. *Alex. J. Fd. Sci. & Technol*, 15(1): 77-88.
- Cross, J. V. (1991). Patternation of spray mass flux from axial fan air blast sprayers in the orchard. *British Crop Protection Council Monograph*, 46, 15-22.
- Dahab, M. H., and Eltahir, N. B. (2010) Spray droplet number and volume distribution as affected by pressure and forward speed. *Agricultural Mechanization in Asia, Africa, and Latin America*, 41(4), 36-42.
- Emanuele, S., D'Anneo, A., Calvaruso, G., Cernigliaro, C., Giuliano, M., & Lauricella, M. (2018). The double-edged sword profile of redox signaling: oxidative events as molecular switches in the balance between cell physiology and cancer. *Chemical research in toxicology*, 31(4), 201-210.
- Ganzelmeier, H. (1993). Drift of plant protection products in field crops, vineyards, orchards and hops.
- Ganzelmeier, H., D. Rautmann, G. Backer, K.W. Eichhorn, R. Ipach, E. Kersting, H. Koch, F.-O. Ripke, N. and K. Schmidt (1992): Guidelines for checking plant protection equipment. Part VII: Measuring direct drift when applying liquid plant protection products. Federal Biological Research Centre for Agriculture and Forestry, Braunschweig, Germany.
- He, Y. J., Hua, H. M., Li, X. F., & Shi, J. Z. (2013). Experimental Study on Spray Uniformity of Spraying Machinery. In *Advanced Materials Research*, (671): 1993-1997.

- Hunt, D. (1983) *Farm power and machinery management*. 8th Ed. Iowa State Univ. Press. Ames, Iowa, USA.
- Hussein, L., and Gouda, M. E. L. (2018). *Pomegranate: Cultivation, Pomological Properties, Processing, Global Market and Health Benefits. Pomegranate: Cultivation, Antioxidant and Health Benefits. Food science and technology*, Nova Science Publisher: New York, NY, USA, 267-302. Ltd.
- Matthews, G. (2008). *Pesticide application methods*. John Wiley & Sons.
- Padhee, D., Verma, S., Rajwade, S. S., Ekka, H., Chandniha, S. K., & Tiwari, S. K. (2019). Evaluating the effect of nozzle type, nozzle height and operating pressure on spraying performance using a horizontal spray patternator. *Journal of Pharmacognosy and Phytochemistry*, 8(4), 2137-2141.
- Salyani, M. and R. P. Cromwell (1992). Spray drift from ground and aerial applications. *Transactions of ASAE* 35(4):1113-1120.
- Sehsah, E. M. E. (2007). Study Effect of forward speed and Nozzles Types on the Spray Characteristics of Air Assistance Hydraulic Sprayer. *Misr J. Ag. Eng.*, 24(1): 75-87
- Sehsah, E. M. E. and Kleisinger, S. (2009). Study OF some Parameters Affecting Spray Distribution Uniformity Patteren. *Misr J. Ag. Eng.*, 26(1): 69- 93.
- Subr, A., Milanowski, M., Parafiniuk, S., & Sawa, J. (2017). Testing the uniformity of spray distribution under different application parameters. IX International Scientific Symposium "Farm Machinery and Processes Management in Sustainable Agriculture", Lublin, Poland, 2017
- Tayel, S., Elnakib, A., Kamel, O., and Soliman, A. (2009) Development and Evaluation of rice transplanting machine to use as spraying for cotton crop. The 16th Annual Conference of the MISR Society of Ag. Eng., 25 July, 2009.
- Triloff, P (2005) An extended tree roe volume dosing model: adjusting pesticide dose rate, water volume and air volume rate by forward speed. *Ann Rev Agric Eng* 4(1):69-80.
- Triloff, P (2011) loss-reduced plant protection in tree fruit growing — minimization of drift and increased efficiency through tree shape-dependent dosage and ventilation. Publishing house Ulrich E, Grauer
- Višacki, V. V., Sedlar, A. D., Gil, E., Bugarin, R. M., Turan, J. J., Janic, T. V., & Burg, P. (2016). Effects of sprayer boom height and operating pressure on the spray uniformity and distribution model development. *Applied Engineering in Agriculture* 32(3), 341-346.

تعديل آلة رش المبيدات لتناسب اشجار البساتين

يسرى عبد القوي شعبان، حسام محمد طلحة الغباشي، محمد عبد الجواد احمد ابو عجيبة و سامي عبد الجيد مرعي
معهد بحوث الهندسة الزراعية – مركز البحوث الزراعية – دقي – جيزة

تهدف هذه الدراسة الى تطوير آلة رش شائعة الاستخدام في المزارع المصرية (gun sprayer, Alcon Motori) للاستخدام في رش اشجار البساتين. وفي هذا التطوير تم تشغيل الآلة عن طريق عمود PTO خلف الجرار بين اشجار البساتين لرش صفيين متقابلين من الاشجار بحيث تتحرك الرشاشات في حركة ترددية رأسية لتحسين ترسيب المبيد على اعلى واسفل الاوراق. شملت المكونات الرئيسية للآلة المطورة للاجزاء التالية: هيكل حامل الرشاش، خزان المبيد، طلمبة ضخ المبيد، منظم ضغط عداد لقياس الضغط، خراطيم لنقل المبيد من الخزان الى الرشاشات، والرشاشات. تم تقييم الآلة تحت ثلاث مستويات من السرعة الامامية وهي 2.4، 3.4، 4.6 كم/ساعة، وثلاثة اطوال لمشوار الرشاش وهي 250، 400، 600 مم، وثلاثة ضغوط تشغيل وهي 1000، 1500، 2000 كيلو باسكال. تم تقييم الرشاشة على اسس كثافة ترسيب (عدد القطيرات لكل سم²) المبيد على سطحي الورقة، ومتوسط مقدر القطيرات، محل الاضافة، والسعة الحقلية الفعلية، وتكاليف عملية الرش. اوضحت النتائج ان زيادة السرعة الامامية للآلة أدت الى انخفاض عدد القطيرات على سطحي الورقة، ومتوسط قطر قطيرات الرش، ومحل اضافة المبيد للحقل، وتكاليف عملية الرش في حين أدت الى زيادة السعة الحقلية الفعلية، كما اظهرت النتائج ان كثافة الرش، ومتوسط قطر القطيرات تتناسب عكسيا مع طول مشوار التردد للرشاشات. أعطى ضغط التشغيل 2000 كيلو باسكال اعلى كثافة ترسيب على سطحي الورقة، واقل قطر قطيرات الرش عند جميع السرعات الامامية واطوار مشوار التردد المستخدمة.