

# THE INFLUENCE OF ARCHITECTURAL ELEMENTS OF FOOD COURTS ON USERS VISITING BEHAVIOR: A QUESTIONNAIRE SURVEY

Dr. EMAD H. RABBOH

## ABSTRACT

Food courts are an architectural element inherent to contemporary malls. Extensively, food environment studied, in terms of psychological, cognitive and marketing. The architectural elements of food courts (AEOFC) require further studies. a field study conducted to determine the subjective evaluation of (AEOFC) from users' perspective, the study occurred in 6 food courts with diverse areas located in various commercial centers area, ranging from 25000 m<sup>2</sup> to 276000 m<sup>2</sup> located in Cairo, Egypt. Based on a questionnaire distributed to 224 users, the relationship between (AEOFC) and visiting behaviors (VB), whether revisiting (RV) or staying long (SL), were verified by the Spearman test. The most important (AEOFC) that engage visitors are studied by linear regression. The proposed conceptual framework was validated by Structure Equation Model (SEM). Pearson Chi-Square test utilized to measure the study variables. The results indicate that; the décor mood and the food courts' illumination have statically significant predictors for a (RV). As for the (SL) in the food court, the décor mood is also the most important followed by illumination and colors.

The results illustrated a similarity between the subjective evaluations of the statistical sample groups (gender, age, type of visit and visit period). The findings illustrate that; Visit day (VD) either weekday or weekends has a correlation with finishes evaluation (FE), décor evaluation (DE). Besides, visiting time (VT) morning or evening has a correlation with the evaluation of illumination. Strong relationship between (FE), (DE) and the visit time (VT). Eventually, the visit time (VT) has a strong relationship with (RV) (SL).

**Keywords:** food court architectural elements, subjective evaluation, visiting behavior.

## 1-INTRODUCTION

Shopping malls and food courts have become appropriate solution for many individuals and families. Therefore, the attraction/avoidance of visitors should be studied based on the physical environment and (AEOFC). The commercial centers represent a temporary trend that is rapidly dominated by the newly established commercial centers. Therefore, customer satisfaction and comfort is a constant attraction, so there is a need to explore what satisfies visitors and attracts them to visit the food courts. Currently, Food courts have become a haven for busy people, in addition to offering a variety of foods that are not provided by specialty restaurants<sup>1</sup>. Currently, dining joined Shopping in commercial centres, thus, the food courts became inherent to the shopping malls, in order to complete the process of entertainment in

Canadian International College (CIC)-Cairo. Egypt.  
Email address: emadeldin\_hamdy@cic-cairo.com

an integrated manner. Numerous restaurants located in shopping malls present different types of food for visitors; the outlets of these restaurants have a direct overlook of the public food court. The need to create a comfortable and breathtaking indoor environment has emerged; many people and families want a remarkable experience by dining out of their usual home environment. Eating out is inherent to the shopping experience. Consequently, dining out is not just dining but enjoying a pleasant/exciting environment.

### 1-1-The significance of the study

Various studies have been undertaken on food courts in different disciplines; visitors' services cape elements discussed<sup>2</sup>, food courts management to engage new visitors tested<sup>3</sup>, sustainable design in food courts argued<sup>4</sup>, the sounds and noises in food courts examined<sup>5</sup>, The influence of music on

visitors' behaviors and emotions investigated<sup>6,7,8,9,10</sup>. K. Quartier et al. (2008) discuss the impact of illumination on users and their impact on their perception in space. The loyalty of visitors to the building and the reasons for repeated visits to the facility have been reviewed in various references<sup>11,12,13</sup>, in addition to, the impact of the indoor physical environment on providing a suitable atmosphere for the facility function (Laboratories, hospitals, restaurants, commercial centers, stores), which helps to achieve the main function of the building<sup>14,15,16</sup>. Evaluating users' preferences of the physical environment architectural elements in general and the food environments in particular studied from a psychological and cognitive approach in different studies<sup>17,18,19,20,21,22</sup>, different types of dining environments at all levels examined in various studies, besides, the most important visiting behavior factors are (RV) and (SL)<sup>23</sup>. In contrary, there's a lack of knowledge on architectural studies for food courts design. The current study has theoretical and practical significance, via collecting the primary data through questionnaire survey technique, it's differs from the previous studies, by studying the elements of the (AEOFC), via selecting the study sample, which represents the most famous food courts in the city of Cairo, the capital of Egypt, the proposed food courts examined by focusing on the priorities of the elements of the physical environment as well as determine the percentage of user satisfaction, and the impact of the (AEOFC) on the behaviors of visitors in one hand, and the influence of detailed architectural elements in particular on the other hand, besides, the relationship to approach or avoidance of visitors. Determining the most important elements which engage visitors to the food courts tested. A major component of the food court environment users' evaluation for the diverse architectural elements and atmospheric stimuli [illumination evaluation (IE)-colors evaluations (CE)-finishes evaluations (FE)-decorative mood evaluations (DE)-dinescape evaluations (DSE)]<sup>24,25</sup> The recent study provides the architects/stakeholders insights on the characteristics and priorities of (AEOFC).

**1-2-Study objective, questions and hypothesis**

The main objective of this study is to examine the users' evaluation of (AEOFC), to help architects in deeply understanding for the users of the food courts subjective evaluations, in addition to, determine which components of (AEOFC), have a positive evaluation, in order to help designers to focus on and develop these elements. Determine the relationship between the components of (AEO-

FC) and the (RV) of food court or (SL) one of the current study objective. Statistical differences between gender (male-female), age, visit frequency (VF) first visit or repeated visit, visit period (VP) less than 1 hour or 1-2 hours or more than two hours, visit day (VD) weekday or weekend, visit time (VT) afternoon or evening, and their effect on user evaluation and visiting behaviors (VB) the final objective of the present study. Based on the above objectives, there are three questions for this study:

**Q1:**

Are the users' of food court evaluating the (AEOFC) positively?

To respond to the Q1, the study hypothesized the following hypotheses:

**H1:**

The (AEOFC) have positive evaluation from the user's perspective.

**Q2:**

Are (AEOFC) users' evaluation having positive correlation on visiting behavior (revisit-stay longer)?

The current study proposed conceptual framework as shown in Fig. (1), additionally, hypothesized the following hypothesis to answer Q2:

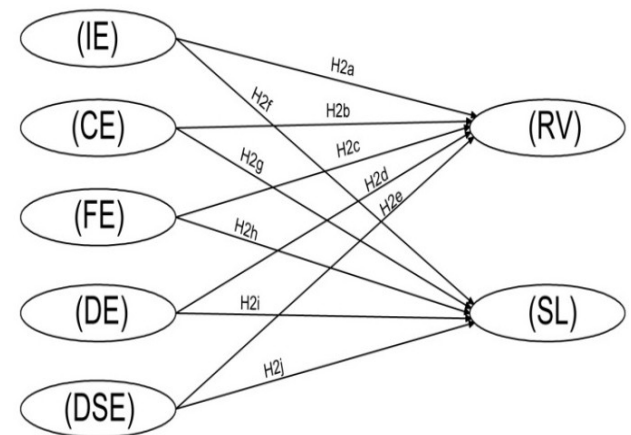

Fig. 1- The Proposed conceptual model. Source: author

<b>H2:</b> The components of (AEOFC) evaluation have positive correlation with visiting behavior (VB).	
<b>H2a:</b> There is a correlation between (IE) of food court and (RV)	<b>H2f:</b> There is a correlation between (IE) of food court and (SL)
<b>H2b:</b> There is a correlation between (CE) of food court and (RV)	<b>H2g:</b> There is a correlation between (CE) of food court and (SL)
<b>H2c:</b> There is a correlation between (FE) of food court and (RV)	<b>H2h:</b> There is a correlation between (FE) of food court and (SL)
<b>H2d:</b> There is a correlation between (DE) of food court and (RV)	<b>H2i:</b> There is a correlation between (DE) of food court and (SL)
<b>H2e:</b> There is a correlation between (DSE) of food court and (RV)	<b>H2j:</b> There is a correlation between (DSE) of food court and (SL)

<b>H2e:</b> There is a correlation between (DSE) of food court and (RV)	<b>H2i:</b> There is a correlation between (DSE) of food court and (SL)
--	--

**Q3:**

Is there significant correlation between demographic characteristics/visiting status and (AEOFC)/(VB)?

In order to answer the Q3, the paper hypothesized the following hypotheses:

<b>H3a:</b> there's a correlation between gender and (AEOFC)/ (VB).	<b>H3d:</b> there's a correlation between Visit period (VP) and AEOFC) / (VB).
<b>H3b:</b> there's a correlation between age and (AEOFC)/ (VB).	<b>H3e:</b> there's a correlation between Visit day (VD) and (AEOFC)/ (VB).
<b>H3c:</b> there's a correlation between Visit frequency (VF) and (AEOFC)/ (VB).	<b>H3f:</b> there's a correlation between Visit time (VT) and (AEOFC)/ (VB).

**2-METHODS**

Literature in a variety of disciplines related to the influence of Atmospheric stimuli, environmental psychology marketing and promotions researches, retail and commercial buildings, marketing managements, architectural and interior design of public buildings, Management and Business Economics reviewed. Consequently, the study variables is set, the study consists of independent variables consists of; users' demographic characteristics, visit status (VS), and dependent variables consists of; user's evaluation of (AEO FC), food courts' users' behavior. The associations between the previous variables were tested to achieve the study objectives. In order to measure the hypotheses of the study, a conceptual framework was proposed, which in turn became a questionnaire. The questions of this questionnaire represent the study questions in detail.

**2-1-Measurements**

The semantic differential method<sup>26</sup> broadly used in the qualitative studies and questionnaires in order to identify user's evaluation/satisfaction and (VB), furthermore, it's widely used in subjective evaluation and the attitude of users toward intangibles characteristics of buildings<sup>27,28,29</sup>. Firstly, the participant asked to fill his/her demographic characteristics and (VS), (VF), (FP), (FD), (FT). Secondly, The participants were asked to rate two parts, part (1) evaluation of physical environment users' satisfaction for architectural element (Illumination, color, décor mod, finished, din-escape), the answers start from strongly satisfied to completely dissatisfied, whereas, part (2) investigate 2 questions of (VB), **A:** the influence of physical elements encourage the users' to revisit again, **B:** the

influence of physical elements encourage staying longer than he/she planned, the answers of this two questions start from strongly agree to completely disagree. The questionnaire was designed in two phases. The first phase is the pilot questionnaire. The pilot questionnaire was distributed to a number of food courts' users. Questions consistency and understanding were calculated by Cronbach's alpha<sup>30</sup> score, and exceed than 70%. The pilot questionnaire was retrofitted based on the above. The final questionnaire was designed to be distributed on 224 food courts visitors from 23/10/2019 to 7/11/2019.

**2-2-Data collection**

Sampling designed as follows; six food courts in 6 commercial centers were selected from the most important commercial centers in Cairo (30.0444°N, 31.2357°E) the capital of Egypt. These food courts are identified as follows: 1. Mall of Arabia food court (F.c.1), 2. City Stars Mall food court (F.c.2), 3. Mall of Egypt food court (F.c.3), 4. City Centre Mall food court (F.c.4), 5. Sun city Mall food court (F.c.5), 6. C.F.C. Mall food court (F.c.6), these food courts are located in a divers stories, from ground floor to the 8<sup>th</sup> floor, images for the study food courts in fig. (2).



In order to achieve expressive sampling sites, there is diversity in the areas of the malls where the food courts are located from 25000 m<sup>2</sup> to 276000 m<sup>2</sup>, with the choice of similar social characteristics in food courts locations, as well as the food courts under study in the four divers geographical directions of Cairo, moreover, the questionnaire distributed at different intervals of the day. The selected sampling method is stratified random sampling<sup>31</sup>,

in order to reach a homogenous population; the respondents were also selected through a direct interview to clarify the questionnaire. The respondents intercept data gathering method was adopted.

**2-3-Data analysis**

Data validation conducted via calculating alpha Cronbach's reliability test. Cronbach's alpha score was 0.90 for the final questionnaire; this indicates the quality and consistency of the questionnaire.

The trustworthiness of the results proven, hence, the result can be generalized. SPSS v. 20 was utilized for data entry and analysis. Pearson Chi-Square, Spearman test, linear regression test, utilized in order to test study hypotheses. The proposed model was validated by causal approach and Structure Equation Model (SEM)<sup>32</sup>. The proposed statistical tests shown in table (1).

Table 1- The proposed tests to confirm or reject the study hypothesis. Source: author

Question	Hypothesis	Test	Significance
Q1	H1	Statistical mean	N/A
Q2	H2, H2a, H2b, H2c, H2d, H2e, H2f, H2g, H2h, H2i, H2j	Spearman, linear regression	P value, t Value
Q3	H3a, H3b, H3c, H3d, H3e, H3f	Pearson Chi-Square	p value

**3-RESULTS**

**3-1-Profile of participants**

Data were obtained from 23/10/2019 to 7/11/2019, the number of respondents was 224 persons, the missing data were excluded in all questions, the study sample consists of 106 (48.4%) males, 113 (51.6%) Female, the study sample was divided into four age group construction groups (from 18 to 30

n=156, from 31 to 45 n=52, from 46 to 60 n=14, bigger than 60 n=2). Based on (VC) the participants divided into two groups (first visit n=12, repeat visit n=190). There are three groups according to (VP) as, 1 Hour or Minimum (n=66), From 1 Hour to 2 Hours (n=78), Bigger than 2 Hours (n=78). The valid percent for all cases in table (2).

Table 2- The Participants' demographic characteristics, Source: author

Gender		Age		Visit category		Visit period	
Male	48.4%	From 18 to 30	69.6%	First visit	5.9%	1 Hour or Minimum	29.8%
Female	51.6%	From 31 to 45	23.2%	Repeat visit	94.1%	From 1 Hour to 2 Hours	35.1%
		From 46 to 60	6.3%			Bigger than 2 Hours	35.1%
		Bigger than 60	0.9%				

**3-2-(AEOFC) users' evaluation**

The qualitative method of responding to the questionnaire was selected. It consists of 7-point scales to be chosen from the respondents, starting from strongly satisfied represented by score (7) to completely dissatisfied represented by score (1). The average opinion of the participants for the illumination is that the illumination is satisfied with score (4.6). The evaluation of the respondents to the colors is satisfied (4.4), the study sample opinion toward finishes were satisfied with score

(4), the study population considered the décor mood was satisfied by score (4.1).

The dinescape was satisfied with score (4.2) according to study sample, as showed in Fig. (3). Thus, H1 is proven. The mean of users' evaluation of (AEOFC), illumination, color, finishes, décor mood and dinescape, of the 6 food courts where the questionnaires were filled illustrated in fig. (3b).

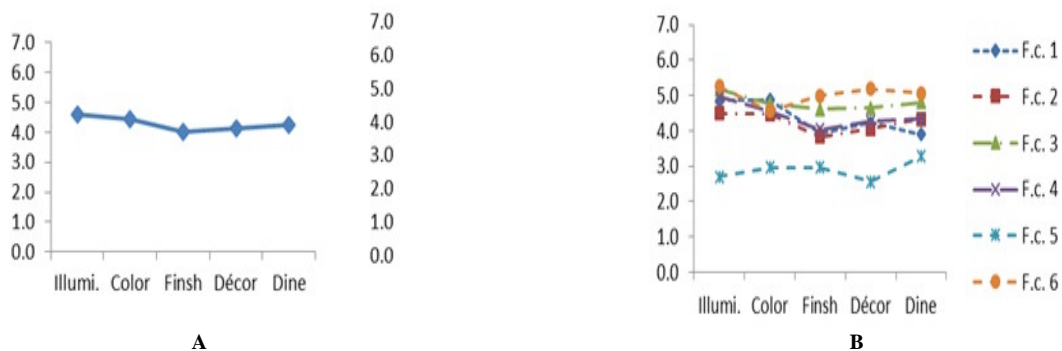

Fig. 3- A: the mean score for evaluation of participants. Fig. 3- B: the average users' opinion of the architectural elements. Source: author

**3-3-The correlation between users' evaluation and visiting behavior**

To examine the relationship between the two ordinal variables (user satisfaction-visiting behavior), the Spearman's test<sup>33</sup> is used, Spearman's test is a non-parametric test used in questionnaires

involving non-parametric data. There's a positive correlation and association is significant at the 0.01 level since  $r = 58.5\%$ . Consequently, H2 is proven. Structure Equation Model (SEM) utilized to conf-

firm hypotheses of conceptual model, as shown in fig. (4). In order to confirm the hypotheses of the current study, Standardized Coefficients were calculated for the relationships between (AEOFC) items

and visiting behaviors. Standardized Coefficients are used to compare factors with different units of measurement<sup>34</sup>, as the higher value of the coefficient, as more positive correlation.

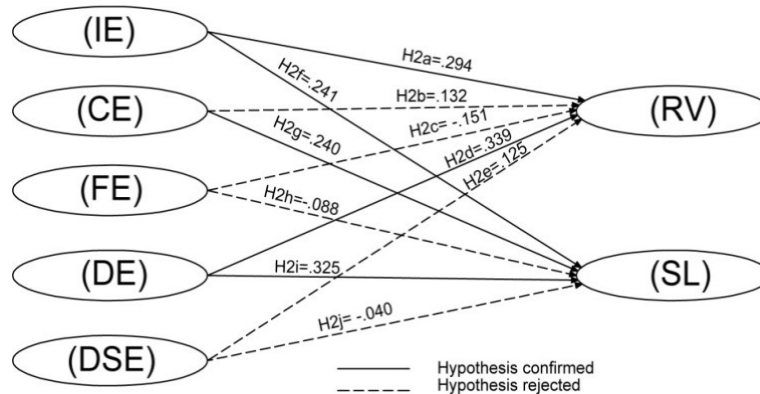

Fig 4- (SEM) for users’ evaluation and visiting behavior causal relationship. Source: author.

Significant measurements were calculated by and  $\rho$ -value  $\leq 0.05$ , that means there’s a statistically significant and vice versa<sup>35</sup>, hence, the hypothesis

calculating t-value and  $\rho$ -value. If t-value  $\geq 1.96$  is proved or not as shown in table (3).

Table 3- Standardized coefficients and significant for the study correlation paths. Source: author

Correlation path	Hypothesis	Standardized Coefficients	t Value*	Sig.*	Hypothesis status
Illumination evaluation (IE) □ Revisit (RV)	H2a	.294	3.345	.001	Confirmed
Color evaluation (CE) □ Revisit (RV)	H2b	.132	1.613	.108	Rejected
Finishes evaluation (FE) □ Revisit (RV)	H2c	-.151	-2.084	.038	Rejected
Decor mood evaluation (DE) □ Revisit (RV)	H2d	.339	4.602	.000	Confirmed
Dinscape evaluation (DSE) □ Revisit (RV)	H2e	.125	1.915	.057	Rejected
Illumination evaluation (IE) □ Revisit (SL)	H2f	.241	2.663	.008	Confirmed
Color evaluation (CE) □ Revisit (SL)	H2g	.240	2.851	.005	Confirmed
Finishes evaluation (FE) □ Revisit (SL)	H2h	-.088	-1.181	.239	Rejected
Decor mood evaluation (DE) □ Revisit (SL)	H2i	.325	4.279	.000	Confirmed
Dinscape evaluation (DSE) □ Revisit (SL)	H2j	-.040	-.588	.557	Rejected

Note: \*Significant at  $\rho \leq 0.05$  if t value  $\geq 1.96$

Fig. (4) Illustrate that the relationship between (AEOFC) and the elements of (VB) is statically significant and positive association, except the relationship between; Color Evaluation (CE)/ Revisit (RV). There’s no correlation between Finishes Evaluation (FE) and [Revisit (RV) Stay Longer (SL)]. Similarly, the association between Dine-scape (DSE) and [Revisit (RV) Stay Longer (SL)] not confirmed. The hypothesis (H2a, H2d, H2f, H2g, H2i) is confirmed because the significant was

$< 0.05$ . In contrary, (H2b, H2c, H2e, H2h, H2j) was rejected as the significant was  $> 0.05$ .

**3-4-Demographic characteristics /user evaluation / visiting behavior correlation**

As revealed from Table (4) the differences between the subjective evaluations of the participants based on gender/age; there are no statistically significant differences between males and females and evaluation of (AEOFC)/ (VB), since the chaisquare test  $\rho$  value  $> 0.05$ .

Table 4-Chi square test for demographic characteristics/ (VS) vs. (AEOFC)/ (VB). Source: author.

		(AEOFC)					(VB)	
		(IE)	(CE)	(FE)	(DE)	(DSE)	(RV)	(SL)
Demographic characteristics	Gender	0.395	0.073	0.227	0.508	0.080	0.150	0.125
	Age	0.508	0.13	0.048	0.854	0.232	0.986	0.880
Visiting status (VS)	Visit frequency (VF)	0.714	0.157	0.291	0.409	0.221	0.979	0.341
	Visit period (VP)	0.180	0.743	0.140	0.211	0.056	0.217	0.234
	Visit day (VD)	0.134	0.655	0.009	0.003	0.358	0.190	0.060
	Visit time (VT)	.. . .	0.063	0.002	0.000	0.139	0.000	0.004

**3-5-Visiting status /user evaluation/visiting behavior correlation**

Table (4) demonstrate the association between the subjective rating of the participants and vising status (VS), (VF), (VP), (VD), (VT); there’s a correlation between visit (VD) and (FE) (DE),

since,  $\rho$  value  $< 0.05$  the association between (VT) and (IE) (FE) (DE) (RV) (SL) statistically significant, since the chaisquare test  $\rho$  value  $< 0.05$ , this means that the hypothesis (H3e) (H3f) is

confirmed. All other variables do not have a statistical correlation, this indicates that the hypotheses (H3a) (H3b) (H3c) (H3d) are rejected.

Table 5- Final status of hypothesis. Source: author.

Hypothesis	Proven/unproven status
H1, H2, H2a, H2d, H2f, H2g, H2i, H3e, H3f	Proven
H3a, H3b, H3c, H3d, H2b, H2c, H2e, H2h, H2j	unproven

#### 4-DISCUSSION and conclusion

The success of public buildings in general and food courts in particular in engaging the largest number of visitors to the building, the current study aims to measure the subjective evaluation of visitors to food courts, and their satisfaction with (AEOFC), to reach that a questionnaire was designed and distributed to 224 users of 6 food courts in the most famous malls of the city of Cairo. The results were analyzed and it was found that the rating of visitors is positive for all (AEOFC), the highest rating of visitors was the mean of illumination rating (4.4) of (7), which indicates the importance of illumination design for visitors, while the lowest rating was the mean rating of finishing materials (4) from (7). The highest (AEO FC) users' rating was the mean score of illumination in (F.c.6), which indicates the high quality of illumination in this food court, while the lowest (AEOFC) rating was the mean score of decoration in (F.c.5) which indicates this food court needs to develop a decorative mood.

The correlation between (AEOFC) and (VB) was tested by the Spearman test. There is a close relationship between them, which proves the validity of the main hypothesis of the study. This result is in line with previous studies that have demonstrated the positive relationship between (AEOFC) and (VB) in restaurants<sup>36</sup>. According to the proposed structural model, the décor mood the illumination in (AEOFC) has statically significant predictors for revisit the food court because Standardized Coefficients = 0.339, respectively, the rest of the elements are ineffective. As for the stay longer in the food court, the décor mood is similarly the most important architectural features, and then the illumination and colors, where the standardized coefficients .325, .241 and .240 respectively, the rest of the elements have no statistical relationship. Clearly, the most important elements of (AEOFC) from the perspective of users is visual elements (the decoration mood and illumination), which engaging them to visit the food courts, this demonstrates the importance of attention to them greatly by designers.

Regarding the gender and age of the respondents, there were no differences in the evaluation

The final hypothesis' proven/ unproven status shown in table (5).

of each constructs of (AEOFC) or (VB) and the response to the questionnaire in general. Therefore, the classification of respondents has not been taken into account for the results of the study, and this is different from a previous study conducted on residential buildings for age<sup>37</sup>, while for the gender correlation agree with the same previous research, besides, some previous studies on office buildings<sup>39</sup> which showed statically differences between gender and age. The relationship between (AEOFC) and (VF) (VP) has not been proved, this indicating that people visiting the food court for the first time and those who visited it before their evaluation of (AEOFC) did not differ, similarly, visit period (VP), whether the visitors visit less than an hour or a large number of hours does not affect user evaluation for (AEOFC) or (VB), likewise, strong relationship was evident between the visit day (VD) weekdays-weekends and the evaluation of (AEOFC) and (VB), except (FE), (DE) elements, this explanation may be due to the perception of users of the elements of the decor and finishes easily due to lack of congestion in the weekends. Visiting time (VT) morning or evening has a correlation with the evaluation of illumination, which makes sense, and this indicates the need for some food courts to redesign the illumination configuration. Consequently, strong relationship between (FE) (DE) and the visit time (VT), this agrees with the previous point and confirm that the illumination In general, may be low in some food courts and thus affect users' evaluations of the decorative mood and finishes. Obviously, from the table (4) that the visit time (VT) has a strong relationship with (RV) (SL), where the p value = 0.000 < 0.05 and 0.004 < 0.05 respectively.

#### Future studies

The study needs experiment the proposed methodology on other types of buildings, as well as in different geographical scales to generalize the results to all countries. Moreover, nonvisual effects in food courts requires future studies.

#### Acknowledgment

The author would like to thank the CIC administration, as well as all teaching assistants and students who participated in the application of this useful and fruitful experiment.

**REFERENCES**

- 1- Mufidah, N. L. (2012). Pola konsumsi masyarakat perkotaan: studi deskriptif pemanfaatan foodcourt oleh keluarga. *Jurnal Biokultur*, 2, 157-178.
- 2- Kusumowidagdo, A. (2014). Visitor Perception on Food Court Servicescape the Study of Two Shopping Centre Food Courts in Indonesia.
- 3- Arunachalampalawiappan, A. (2014). A Preliminary Study of Food Court Analytics.
- 4- Salim, P. (2017). Modern Concept of Interior Design Food Court as Rebranding Form of Sustainability Design Related to the Growth of Mall (Case Study: Delicaè, Senayan City). *Humaniora*, 8(4), 373-380.
- 5- de Ruitter, E., Smyrnova, Y., & Brown, T. (2015, July). Feedback from the food court. In Proc. of 22nd International Congress on Sound and Vibration, ICSV22, Florence, Italy (pp. 12-16).
- 6- Magnini, V.P., Parker, E.E., 2009. The psychological effects of music: implications for hotel firms, *Journal of Vacation Marketing* 15 (1), 53– 62.
- 7- Ryu, K., Jang, S., 2008a, DINESCAPE: a scale for customers' perception of dining environments. *Journal of Foodservice Business Research* 11 (1), 2–22.
- 8- Turner, L. J. (2012), the impact of music on the shopping behaviors of generation y consumers in a college campus bookstore. University of North Texas.
- 9- Ting, Y. (2015). The Research on the Impact of Background Music on Appetite of Customers in Restaurant. *The Open Cybernetics & Systemics Journal*, 9(1).
- 10- Vida, I., Obadia, C., & Kunz, M, (2007), the effects of background music on consumer responses in a high-end supermarket. *International Review of Retail, Distribution and Consumer Research*, 17(5), 469-482.
- 11- Chebat, J. C., El Hedhli, K., & Sirgy, M. J. (2009), how does shopper-based mall equity generate mall loyalty? A conceptual model and empirical evidence, *Journal of Retailing and Consumer Services*, 16 (1), 50-60.
- 12- Han, H., & Ryu, K. (2009). The roles of the physical environment, price perception, and customer satisfaction in determining customer loyalty in the restaurant industry, *Journal of hospitality & tourism research*, 33(4), 487-510.
- 13- Ergin, E. A., Parıltı, N., & ? zsaçmacı, B. ? . (2007), Impact of Loyalty Cards On Customers Store Loyalty, *International Business & Economics Research Journal (IBER)*, 6 (2).
- 14- Ramlee, N., & Said, I. (2014), Review on atmospheric effects of commercial environment. *Procedia-Social and Behavioral Sciences*, 153, 426-435.
- 15- Huisman, E. R., Morales, E., van Hoof, J., & Kort, H. S. (2012), Healing environment: A review of the impact of physical environmental factors on users, *Building and environment*, 58, 70-80.
- 16- Abbas, M. Y., & Ghazali, R. (2011), Physical Environment: The major determinant towards the creation of a healing environment?. *Procedia-Social and Behavioral Sciences*, 30, 1951-1958.
- 17- Orteg?n-Cort?zar, L., & Royo-Vela, M. (2017), Attraction factors of shopping centers: Effects of design and eco-natural environment on intention to visit. *European Journal of Management and Business Economics*, 26(2), 199-219.
- 18- Ryu, K., & Han, H. (2010), Influence of physical environment on disconfirmation, customer satisfaction, and customer loyalty for first-time and repeat customers in upscale restaurants.
- 19- Ryu, K., & Han, H. (2010), Influence of the quality of food, service, and physical environment on customer satisfaction and behavioral intention in quick-casual restaurants: Moderating role of perceived price. *Journal of Hospitality & Tourism Research*, 34(3), 310-329.
- 20- Hami, A., Moula, F. F., & Maulan, S. B. (2018), Public preferences toward shopping mall interior landscape design in Kuala Lumpur, Malaysia. *Urban Forestry & Urban Greening*, 30, 1-7.
- 21- Premkumar, G., Bhattacharjee, A., 2008, explaining information technology usage: a test of competing models. *Omega* 36, 64–75.
- 22- Jin, H., Li, X., Kang, J. et al. (2017) An evaluation of the illumination environment in the public space of shopping centres, *Building and Environment*, 115. pp. 228-235. ISSN 0360-1323.

- 23- Ryu, K., & Jang, S. S. (2007), The effect of environmental perceptions on behavioral intentions through emotions: The case of upscale restaurants. *Journal of Hospitality & Tourism Research*, 31(1), 56-72.
- 24- Ramlee, N., & Said, I. (2014), Review on atmospheric effects of commercial environment. *Procedia-Social and Behavioral Sciences*, 153, 426-435.
- 25- Ryu, K., & Han, H. (2011). New or repeat customers: how does physical environment influence their restaurant experience?. *International Journal of Hospitality Management*, 30(3), 599-611.
- 26- Lavrakas, P. J. (2008), *Encyclopedia of survey research methods*, Sage Publications.
- 27- Monfared, I. G., & Sharples, S. (2011). Occupants' perceptions and expectations of a green office building: a longitudinal case study. *Architectural Science Review*, 54(4), 344-355.
- 28- D?kmeci, P. N., & Yılmaz, S. (2012). Relationships between measured levels and subjective ratings: a case study of the food-court area in CEPA shopping center, Ankara, *Building Acoustics*, 19(1), 57-73.
- 29- Kang, J., & Zhang, M. (2010), Semantic differential analysis of the soundscape in urban open public spaces, *Building and environment*, 45(1), 150-157.
- 30- Taber, K. S. (2018). The use of Cronbach's alpha when developing and reporting research instruments in science education. *Research in Science Education*, 48(6), 1273-1296.
- 31- Jing, L., Tian, K., & Huang, J. Z. (2015). Stratified feature sampling method for ensemble clustering of high dimensional data. *Pattern Recognition*, 48(11), 3688-3702.
- 32- Brandmaier, A. M., Prindle, J. J., McArdle, J. J., & Lindenberger, U. (2016), Theory-guided exploration with structural equation model forests, *Psychological Methods*, 21(4), 566.
- 33- Akoglu, H. (2018), User's guide to correlation coefficients, *Turkish journal of emergency medicine*, 18(3), 91-93.
- 34- Menard, S. (2011), Standards for standardized logistic regression coefficients. *Social Forces*, 89(4), 1409-1428.
- 35- Cleophas, T. J., & Zwinderman, A. H. (2016), *Linear Regression (20 Patients)*, In *SPSS for Starters and 2nd Levelers* (pp. 23-28). Springer, Cham.
- 36- Kisang Ryu & Soocheong Jang (2008) **RETRACTED ARTICLE**: Influence of restaurants' physical environments on emotion and behavioral intention, *The Service Industries Journal*, 28:8, 1151-1165, DOI: 10.1080/02642060802188023.
- 37- Xue, P., Mak, C. M., & Cheung, H. D. (2014). The effects of daylighting and human behavior on luminous comfort in residential buildings: A questionnaire survey. *Building and Environment*, 81, 51-59.
- 38- Kim, J., de Dear, R., Candido, C., Zhang, H., & Arens, E. (2013), Gender differences in office occupant perception of indoor environmental quality (IEQ). *Building and environment*, 70, 245-256.
- 39- Choi, J. H., & Moon, J. (2017). Impacts of human and spatial factors on user satisfaction in office environments, *Building and Environment*, 114, 23-35.