

**Power Flow Analysis of Hybrid Renewable Energy Sources in Power System Applied****For IEEE Six Buses**FATHY GHONIMA<sup>1</sup>, M. EZZAT<sup>2</sup>, T.S. ABDEL-SALAM<sup>3</sup><sup>1</sup> Msc student, Department of Electrical Power & Machine, Faculty of Engineering, Ain Shams University, Cairo, Egypt<sup>2</sup> Assistant Professor Department of Electrical Power & Machine, Faculty of Engineering, Ain Shams University, Cairo, Egypt<sup>3</sup> Professor Faculty of Energy and Environmental Engineering, The British University in Egypt, Al-Shorouk City, Cairo, Egypt**ARTICLE INFO***Article history:**Received: 2021-07-02**Accepted: 2021-09-01**Online: 2021-09-01***Keywords:**Power flow solution,  
Gauss Seidel method,  
Newton Raphson method,  
Fast Decoupled method**ABSTRACT**

Power flow analysis is a critical tool for power system planning for determination of the best operation and revealing the capability of the hybrid power system to be suitable and efficient for load area. The power flow equation is nonlinear and more measuring time is needed as it becomes more complicated as the number of bus system increases that prevents obtaining accurate results because of continuous changes in power demand and generation. This paper presents an analysis of power flow in hybrid power system using MATLAB software to simulate iterative algorithms such as Gauss Seidel method, Newton Raphson method and Fast Decoupled method for solving the nonlinear power flow equation are used in order to obtain the power flow solution and system losses. The analysis case is applied in steady-state condition for a test case IEEE 6 buses standard system. The paper also illustrates a comparison among power flow study methods according to line loss active power, line loss reactive power, number of iterations, maximum power mismatch and elapsed time. Based on the obtained results, Newton Raphson is found to be more reliable method and accurate because it has the lowest maximum power mismatch and the fastest convergence.

**1. Introduction**

This paper focuses on technical evaluation of a hybrid system of power flow or load flow analysis used to obtain magnitude and phase angle of load bus voltage and also to obtain active and reactive power flow on the transmission line at the reference bus. The different branches of the microgrid network carry power from the generation area to the load area. The flow of active and reactive power assess the power system steady-state operation in order to ensure delivery of electrical power to load areas across the grid in stable, reliable, and finance saving method. [1, 2]

The main aim of load flow calculations is to determine the steady-state operating characteristics for a given load,

FATHY GHONIMA, Faculty of Engineering, Ain Shams University, Egypt, +201007820470, [fathyghonima2017@gmail.com](mailto:fathyghonima2017@gmail.com).

power, and voltage conditions, in order to use that knowledge to calculate active and reactive power flow in all branches together with power losses. [3]

All features of the digital computer such as efficiency, large memory, flexibility, and speed assist the numerical methods in determining the best approach for the load flow analysis. [3]

Power flow analysis is a comprehensive statistical approach to estimate bus voltages, phase angles, active and reactive power in different branches of the network through the power system. The load flow study was made to determine the performance of hybrid power system for power generating buses at reference bus [3] [4].

The losses in one particular case line can be calculated using MATLAB Load-flow programming also each line

active power and reactive power flow. In addition, assess the over and under load conditions from the line flow. The steady-state power and reactive power is given by a bus in the power network is expressed in terms of algebraic nonlinear equations. [5]

To increase the size of the power system, the dimension of the power flow equation shall be increased to make it impossible for the power flow numerical mathematical approach to converge to the perfect solution. This is useful for power system engineers who seek reliable techniques to achieve precision load flow solution in a short time. [3, 5]

This research is carried out for the case of nonlinear nodal power flow equation; at different types of buses line flow and losses, in the hybrid power system that required iterative techniques to solve power flow equation. This is accomplished using numerical methods such as the Gauss Seidel method, the Newton Raphson method, and the fast Decoupled method. [6, 7]

The Gauss Seidal method deals with nodal power flow equation as matrices with non- zero diagonal elements. Features of the Gauss Seidal method are the variables expressed in rectangular coordinates. The linear convergence characteristics lead to poor convergences properties also the choice of slack bus is critical. [7, 8].

Newton Raphson method is comparatively good, and the solution leads to divergence The Features of The Newton Raphson method are that variables are expressed in polar coordinates. The quadratic convergence characteristics lead to fast convergences properties while the choice of slack bus is arbitrary. [3, 7, 8]

The Fast decoupled method is a derivative of Newton Raphson method which is designed in polar coordinates with a few assumptions to make the Jacobian matrix simple to solve that results in a fast algorithm for load flow solution. [3, 9, 10]

In this paper the power flow study made by the PSAT Matlab toolbox for hybrid power system located in IEEE six buses system then applying the three load flow methods by using MATLAB code.

## 2. Power Flow Analysis Methods

The numerical analysis is used to solve the power flow equations [3, 11]. At the beginning formation of Y bus admittance is needed by using the nodal equation in equation (1) for power system network.

$$I = Y_{Bus}V \quad (1)$$

Where  $Y_{Bus}$  is the bus admittance. Equation (2) show nodal equation for n buses.

$$I_i = \sum_{j=1}^n Y_{ij}V_j \quad \text{for } i=1,2,3,n \quad (2)$$

Where  $Y_{ij}$  is the bus admittance, n is the bus number.

Equations (3), (4) present the nodal equation for the case of complex power.

$$P_i + jQ_i = V_i I_i^* \quad (3)$$

Where  $P_i$  is the real power,  $Q_i$  is the reactive power,  $V_i$  is voltage magnitude.

$$I_i = \frac{P_i - jQ_i}{V_i^*} \quad (4)$$

Where  $V_i^*$  is conjugate of voltage magnitude.

Substituting for  $I_i$  of equation (4) in equation (2), the equation (5) gives nonlinear equation.

$$\frac{P_i - jQ_i}{V_i^*} = V_i \sum_{j=1}^n y_{ij} - \sum_{j=1}^n y_{ij} V_j \quad j \neq i \quad (5)$$

Iterative methods techniques are used to solve power flow problems in equation (5)

There are various methods of power flow technique such as the Gauss Seidel method, Newton Raphson method, and Fast Decoupled method.

In the following analysis of each method is applied to solve power flow nonlinear equation

### 2.1 Gauss-Seidel Method:

It is an iterative method for solving nonlinear equations that starts with an initial guess at the voltage value. Replace the measured voltage value with the initial guess of voltage, and repeat until the solution converges. Equation (6) is used in this method. [7]

$$V_i^{(k+1)} = \frac{\frac{P_i^{sch} - jQ_i^{sch}}{V_i^*} + \sum y_{ij} V_j^{(k)}}{\sum y_{ij}} \quad j \neq i \quad (6)$$

Kirchhoff's current law is applied so the power is moving away from the buses, in both active and reactive power as shown in the equations (7), (8).

$$P_i^{(k+1)} = Real \left[ V_i^{*(k)} \left\{ \sum_{i=0}^n y_{ij} - \sum_{ji}^n V_i^{(k)} \right\} \right] \quad j \neq i \quad (7)$$

$$Q_i^{(k+1)} = Imaginary \left[ V_i^{*(k)} \left\{ \sum_{i=0}^n y_{ij} - \sum_{ji}^n V_i^{(k)} \right\} \right] \quad j \neq i \quad (8)$$

The measured voltage, active and reactive power in terms of Y bus admittance and non-diagonal elements are shown in equations (9),(10),(11).

$$V_i^{(k+1)} = \frac{\frac{P_i^{sch} - jQ_i^{sch}}{V_i^{*(k)}} + \sum Y_{ij} V_j^{(k)}}{Y_{ii}} \quad (9)$$

$$P_i^{(k+1)} = Real \left[ V_i^{*(k)} \left\{ V_i^{*(k)} Y_{ii} - \sum_{j=1, j \neq i}^n Y_{ij} V_j^{(k)} \right\} \right] \quad j \neq i \quad (10)$$

$$Q_i^{(k+1)} = Imaginary \left[ V_i^{*(k)} \left\{ V_i^{*(k)} Y_{ii} - \sum_{j=1, j \neq i}^n Y_{ij} V_j^{(k)} \right\} \right] \quad j \neq i \quad (11)$$

Where  $P_i^{sch}, Q_i^{sch}$  is scheduled active and reactive power.

### 2.2 Newton Raphson Method:

It is an iterative method using Taylor's series expansion for solving nonlinear equations. The Newton Raphson method is the most commonly used iterative method because of its powerful convergence to other methods and the fast produced results. This approach has formula or mathematical steps that are used in order to solve the power flow problem [3][11].

The current enter power system in equation (12).

$$I_i = \sum_{j=1}^n Y_{ij} V_j = \sum_{j=1}^n Y_{ij} V_j \angle (\theta_{ij} + \delta_j) \quad (12)$$

Where  $Y_{ij}$  is the bus admittance, n is the bus number and  $V_j$  is voltage magnitude.

Active and reactive powers are shown in equation (13).

$$P_i - jQ_i = V_i^* I_i \quad (13)$$

Where  $V_i^*$  is conjugate of voltage magnitude at bus i,

Equation (14) is derived by comes substituting for  $I_i$  of equation (12) in equation (13).

$$P_i - jQ_i = (V_i \angle -\delta_i) * (\sum_{j=1}^n |Y_{ij}| |V_j| \angle \theta_{ij} + \delta_j) \quad (14)$$

Equations (15) & (16) show active power and reactive power as stated in equation (14).

$$P_i = Re\{V_i^* \cdot I_i\} = \sum_{j=1}^n |V_i| |V_j| |Y_{ij}| \cos(\theta_{ij} - \delta_i + \delta_j) \quad (15)$$

$$Q_i = -Im\{V_i^* \cdot I_i\} = \sum_{j=1}^n |V_i| |V_j| |Y_{ij}| \sin(\theta_{ij} - \delta_i + \delta_j) \quad (16)$$

Where  $V_i$  is voltage magnitude at bus i,  $V_j$  is voltage magnitude at bus j,  $\delta_i$  is the phase angle,  $\delta_j$  is the phase angle at bus j.

Two equations (15), (16) are solved using Taylor's series to achieve linear equation in equation (17).

$$\begin{bmatrix} \Delta P_2^{(k)} \\ \vdots \\ \Delta P_n^{(k)} \\ \Delta Q_2^{(k)} \\ \vdots \\ \Delta Q_n^{(k)} \end{bmatrix} = \begin{bmatrix} \frac{\partial P_2^{(k)}}{\partial \delta_2} & \dots & \frac{\partial P_2^{(k)}}{\partial \delta_n} & \frac{\partial P_2^{(k)}}{\partial |V_2|} & \dots & \frac{\partial P_2^{(k)}}{\partial |V_n|} \\ \vdots & \ddots & \vdots & \vdots & \ddots & \vdots \\ \frac{\partial P_n^{(k)}}{\partial \delta_2} & \dots & \frac{\partial P_n^{(k)}}{\partial \delta_n} & \frac{\partial P_n^{(k)}}{\partial |V_2|} & \dots & \frac{\partial P_n^{(k)}}{\partial |V_n|} \\ \frac{\partial Q_2^{(k)}}{\partial \delta_2} & \dots & \frac{\partial Q_2^{(k)}}{\partial \delta_n} & \frac{\partial Q_2^{(k)}}{\partial |V_2|} & \dots & \frac{\partial Q_2^{(k)}}{\partial |V_n|} \\ \vdots & & \vdots & \vdots & \ddots & \vdots \\ \frac{\partial Q_n^{(k)}}{\partial \delta_2} & \dots & \frac{\partial Q_n^{(k)}}{\partial \delta_n} & \frac{\partial Q_n^{(k)}}{\partial |V_2|} & \dots & \frac{\partial Q_n^{(k)}}{\partial |V_n|} \end{bmatrix} \begin{bmatrix} \Delta \delta_2 \\ \vdots \\ \Delta \delta_n \\ \Delta |V_2| \\ \vdots \\ \Delta |V_n| \end{bmatrix} \quad (17)$$

(17)

Equation (18) represents the Jacobian matrix obtained by the partial derivatives the linear equation of voltage magnitude and phase angle using Taylor's series to simplify the matrix.

$$\begin{bmatrix} \Delta P \\ \Delta Q \end{bmatrix} = \begin{bmatrix} J_1 & J_3 \\ J_2 & J_4 \end{bmatrix} \begin{bmatrix} \Delta \delta \\ \Delta |V| \end{bmatrix} \quad (18)$$

$J_1, J_2, J_3, J_4$  are the elements of Jacobian matrix

Equations (19), (20) shows the term  $\Delta P$  and  $\Delta Q$  which are the difference (the mismatch) between the specified and calculate values.

$$\Delta P_i^{(k)} = P_i^{Spec} - P_i^{(k)} \quad (19)$$

$$\Delta Q_i^{(k)} = Q_i^{Spec} - Q_i^{(k)} \quad (20)$$

Equations (21), (22) are the new estimates for bus voltage

$$\delta^{(k+1)} = \delta_i^{(k)} + \Delta \delta_i^{(k)} \quad (21)$$

$$|V_i|^{(K+1)} = |V_i|^{(K)} + \Delta |V_i|^{(K)} \quad (22)$$

### 2.3 Fast Decoupled Method:

It is an iterative method based on improving the simplification of the Newton Raphson method [7].

Fast decoupled Method depends on the simple Jacobian matrix as shown in equation (23).

$$\begin{bmatrix} \Delta P \\ \Delta Q \end{bmatrix} = \begin{bmatrix} J_1 & 0 \\ 0 & J_4 \end{bmatrix} \begin{bmatrix} \Delta \delta \\ \Delta |V| \end{bmatrix} \quad (23)$$

Separate equation (23) gives two separate matrices in equations (24), (25).

$$\Delta P = J_1 \Delta \delta = \left[ \frac{\partial P}{\partial \delta} \right] \Delta \delta \quad (24)$$

$$\Delta Q = J_4 \Delta |V| = \left[ \frac{\partial P}{\partial |V|} \right] \Delta |V| \quad (25)$$

Where  $J_1, J_4$  are the elements of Jacobian matrix.

### 3. Simulation Methodology

All the developed models were tested using MATLAB software in IEEE six buses. For the power flow analysis obtained from different methods that are Gauss Seidal method, Newton Raphson method and Fast Decoupled as Respectively. Buses have three type categories, slack bus, PV generator bus, and PQ load bus .in the following introduces the differences between the bus types.

Slack bus is a reference bus to achieve the power balance case. Slack bus adjust generating unit to ensure power balance, the angle of this bus is usually set to zero [3, 7].

PV bus is a voltage control bus where the generation unit is connected. The voltage controlled by adjusting the excitation of the generator reactive power. PV bus depends on the characteristic of each generation unit [3,7].

PQ bus is a non-generator bus that the Load is connected on this bus [3, 7].

Figure 1 shows the flow chart of simulation methodology of power flow study applied to tested hybrid system.

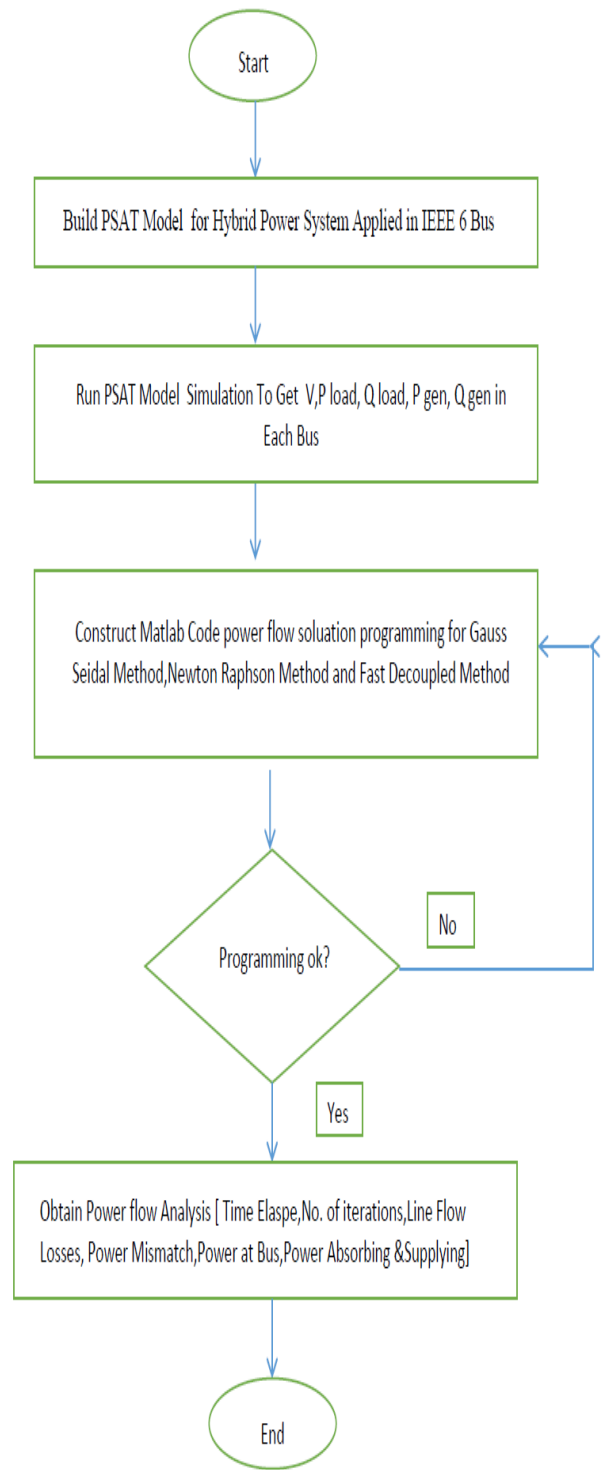

**Figure 1: flow chart of Simulation methodology**

### 4. Simulation Results

The Power flow analysis is performed using PSAT (power system analysis toolbox) software that runs under MATLAB. Power system analysis toolbox (PSAT) is used to build a hybrid system model which consists of

wind turbine, photovoltaic array, Diesel generator and battery as shown in figure (2). PSAT model is used to deliver power to the load area. In PSAT simulation, the power rate is 100[MVA].

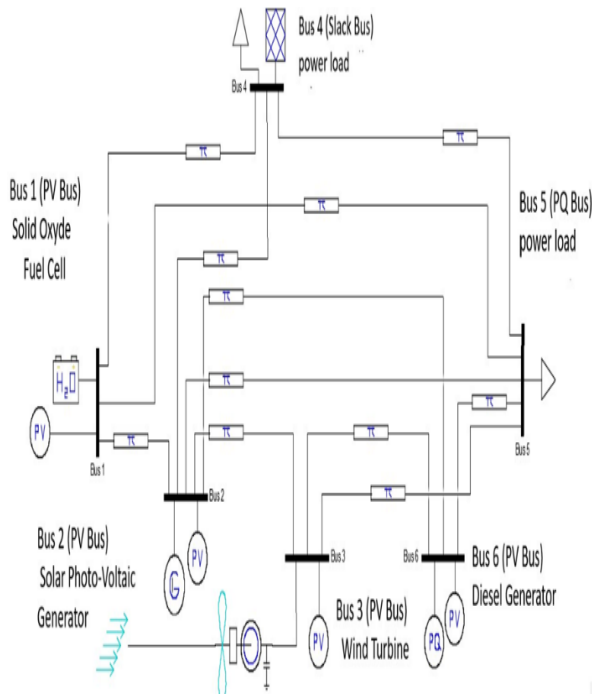

Figure 2: Matlab Model using PSAT toolbox

In table (1) Slack bus which is symbolized by the number (0), PV Bus is symbolized by the number (2) and PQ Bus is symbolized by the number (1).

Figure (2) shows the MATLAB model of hybrid system .the data of PSAT model simulation at each bus are as follows:

Bus 1 (PV Bus) has a Solid Oxide Fuel Cell (0.1204 MWATT, 11 KV)

Bus 2 (PV Bus) has Solar Photo-Voltaic generator (4.263 MWATT, 11 KV)

Bus 3 (PV Bus) has a Constant speed wind turbine with third order asynchronous generator and dynamic shaft (4 MVA, 11 KV)

Bus 4 (Slack Bus) has power load (3 MVA, 11 KV)

Bus 5 (PQ Bus) has power load (3 MVA, 11 KV)

Bus 6 (PV Bus) PQ generator (5.333 MVA,11 KV).The PSAT gave the initial data that help to load flow analysis.

Table 1: Data of study hybrid power IEEE 6 buses system

Bus No.	Bus Type	votage	Phase angle	Qmin	Qmax
1	2	1	0.07793	-0.005	0.032
2	2	1	0.09804	-0.015	0.032
3	2	1	0.16303	-0.011	0.032
4	1	1	0	16.55	21.92
5	0	1.001	0.0004	0	0
6	2	1	0.18916	-0.018	0.074

Table 2: load and generation data of study hybrid power IEEE 6 buses system

Bus No.	Load Pd	Load Qd	Gen Pg	Gen Qg	Qsh
1	0	0	0.032	-0.00558	0
2	0	0	0.032	-0.0156	1.0
3	0	0	0.032	0.01111	1.5
4	22.0386	16.5289	21.9011	16.5419	0
5	0.024	0.018	0.036	0	0
6	0	0	0.07466	-0.01839	0

In Table (2) the abbreviations are (Pd) is active power for the load, (Qd) is reactive power for the load, (Pg) is active power for the power generation unit, (Qg) is reactive power for the power generation unit, and (Qsh) is injection reactive power in each bus.

Table 3: Resistance and Reactance of study hybrid power IEEE 6 buses system in each line.

Bus From	Bus To	R	X	B/2	X tap
1	2	0.10	0.20	0.02	1
1	4	0.05	0.20	0.02	1
1	5	0.08	0.30	0.03	1
2	3	0.05	0.25	0.03	1
2	4	0.05	0.10	0.01	1
2	5	0.10	0.30	0.02	1
2	6	0.07	0.20	0.025	1
3	5	0.12	0.26	0.025	1
3	6	0.02	0.10	0.01	1
4	5	0.20	0.40	0.04	1
5	6	0.10	0.30	0.03	1

In table (3) shows line data of IEEE six buses where R is resistance of line and X is the reactance of the line and B/2 the line loss and X tap is the transformer tap ratio.

Table (1), (2), (3) data put in MATLAB code to study power flow by three methods Gauss Seidal , Newton Raphson , Fast decoupled method in details. Simulation results shown in Tables (4), (5), (6), (7), (8), (9) which have abbreviations are (Volt. Mag.) is voltage magnitude, (MW) is active power in megawatts, (MVAR) is reactive power mega-volt-amperes, (MVA) is active power mega-volt-amperes and (Gene.) is generation unit.

1- Simulation of Power Flow Solution

Ybus is the bus admittance matrix of the hybrid power system as shown in equation (17).

Ybus = [

$$\begin{aligned}
 &4.0063 - 11.7479i \quad -2.0000 + 4.0000i \quad 0.0000 + 0.0000i \quad -1.1765 + 4.7059i \quad -0.8299 + 3.1120i \quad 0.0000 + 0.0000i \\
 &-2.0000 + 4.0000i \quad 9.3283 - 23.1955i \quad -0.7692 + 3.8462i \quad -4.0000 + 8.0000i \quad -1.0000 + 3.0000i \quad -1.5590 + 4.4543i \\
 &0.0000 + 0.0000i \quad -0.7692 + 3.8462i \quad 4.1557 - 16.5673i \quad 0.0000 + 0.0000i \quad -1.4634 + 3.1707i \quad -1.9231 + 9.6154i \\
 &-1.1765 + 4.7059i \quad -4.0000 + 8.0000i \quad 0.0000 + 0.0000i \quad 6.1765 - 14.6359i \quad -1.0000 + 2.0000i \quad 0.0000 + 0.0000i \\
 &-0.8299 + 3.1120i \quad -1.0000 + 3.0000i \quad -1.4634 + 3.1707i \quad -1.0000 + 2.0000i \quad 5.2933 - 14.1378i \quad -1.0000 + 3.0000i \\
 &0.0000 + 0.0000i \quad -1.5590 + 4.4543i \quad -1.9231 + 9.6154i \quad 0.0000 + 0.0000i \quad -1.0000 + 3.0000i \quad 4.4821 - 17.0047i \quad ]
 \end{aligned}$$

Power Flow Solution by Gauss-Seidel Method

Table 4: Gauss-Seidel Method power flow solution in each Bus

No	Volt. Mag.	Angle Degree	Load MW	Load MVAR	Gene. MW	Gene. MVAR	Injec. MVAR
1	1.000	-0.008	0.000	0.000	0.032	-9.992	0.000
2	1.000	0.005	0.000	0.000	0.032	-14.58	1.000
3	1.000	0.022	0.000	0.000	0.032	-11.43	1.500
4	1.000	0.000	22.03	16.52	21.76	7.436	0.000
5	1.009	-0.183	0.024	0.018	0.036	0.000	0.000
6	1.000	0.014	0.000	0.000	0.075	-9.558	0.000
Tot	-----	-----	22.06	16.54	21.97	-38.13	2.500

Power Flow Solution by Newton Raphson Method

Table 5: Newton Raphson Method power flow solution in each Bus

No	Volt. Mag.	Angle Degree	Load MW	Load MVAR	Gene. MW	Gene. MVAR	Injec. MVAR
1	1.030	-0.65	0.000	0.000	0.032	3.137	0.000
2	1.030	-0.79	0.000	0.000	0.032	-4.22	1.000
3	1.050	-1.10	0.000	0.000	0.032	2.257	1.500
4	1.000	0.000	22.03	16.52	22.74	-46.0	0.000
5	1.044	-1.00	0.024	0.018	0.036	0.000	0.000
6	1.050	-1.12	0.000	0.000	0.075	5.528	0.000
Tot	-----	-----	22.06	16.54	22.94	-39.3	2.500

Power Flow Solution by Fast Decoupled Method

Table 6: Fast Decoupled Method power flow solution in each Bus

No	Volt. Mag.	Angle Degree	Load MW	Load MVAR	Gene. MW	Gene. MVAR	Injec. MVAR
1	1.000	-0.01	0.000	0.000	0.032	-9.99	0.000
2	1.000	0.000	0.000	0.000	0.032	-14.5	1.000
3	1.000	0.014	0.000	0.000	0.032	-11.4	1.500
4	1.000	0.000	22.03	16.52	21.9	7.37	0.000
5	1.009	-0.18	0.024	0.018	0.036	0.00	0.000
6	1.000	0.007	0.000	0.000	0.075	-9.54	0.000
Tot	-----	-----	22.06	16.54	22.11	-38.1	2.500

From the results of all power flow methods show that the total load is active power is 22.063 MW and the total load reactive power is 16.547 MVAR and Injected reactive power is 2.5 MVAR are the same in every method. The fastest calculation method is Gauss Seidal method for 0.018134 second.

For power flow solution results, Gauss Seidal method has the total generation active power is 21.972 MW and the total generation reactive power is -38.137 MVAR. For Newton Raphson method has the total generation active power is 22.063 MW and the total generation reactive power is -39.34 MVA, For Fast decoupled method has the total generation active power is 22.111 MW and the total generation reactive power is -38.123 MVAR.



2- Simulation of Line flows and losses  
Line flows and losses by Gauss-Seidel Method

**Table 7: Line power flow and line power loss by Gauss Seidal Method**

From line	To line	MW Bus	Mvar Bus	MVA Bus	Mw Line loss	MVAR Line loss
1	-	0.032	3.137	3.137	-	-
1	2	1.038	-2.639	2.836	0.001	-4.241
1	4	-1.880	13.832	13.959	0.122	-3.635
1	5	0.874	-8.048	8.096	0.018	-6.380
2	-	0.032	-3.226	3.226	-	-
2	1	-1.037	-1.602	1.908	0.001	-4.241
2	3	0.700	-11.556	11.577	0.033	-6.324
2	4	0.997	29.439	29.456	0.439	-1.183
2	5	-0.225	-6.684	6.687	0.020	-4.241
2	6	-0.403	-12.802	12.808	0.068	-5.214
3	-	0.032	3.757	3.757	-	-
3	2	-0.667	5.232	5.275	0.033	-6.324
3	5	0.346	-0.295	0.455	0.007	-5.464
3	6	0.353	-1.173	1.225	0.000	-2.205
4	-	0.704	-62.566	62.570	-	-
4	1	2.001	-17.467	17.581	0.122	-3.635
4	2	-0.558	-30.623	30.628	0.439	-1.183
4	5	-0.693	-14.492	14.509	0.221	-7.913
5	-	0.012	-0.018	0.022	-	-
5	1	-0.855	1.668	1.875	0.018	-6.380
5	2	0.245	2.443	2.455	0.020	-4.241
5	3	-0.339	-5.169	5.180	0.007	-5.464
5	4	0.914	6.579	6.642	0.221	-7.913
5	6	0.049	-5.539	5.539	0.005	-6.560
6	-	0.075	5.528	5.529	-	-
6	2	0.472	7.588	7.603	0.068	-5.214
6	3	-0.353	-1.032	1.091	0.000	-2.205
6	5	-0.044	-1.021	1.022	0.005	-6.560
Total loss					0.934	-53.361

For Line flows and losses results in both methods Gauss Seidal method and Fast decoupled method had the same total line loss active power is 0.049 MW and the same total line loss reactive power is -52.130 MVAR

Line flows and losses by Newton Raphson Method

**Table 8: Line power flow and line power loss by Newton Raphson Method**

From line	To line	MW Bus	MVAR Bus	MVA Bus	MW Line loss	MVAR Line loss
1	-	0.032	-9.991	9.992	-	-
1	2	-0.08	-1.957	1.959	0.000	-4.000
1	4	-0.10	-1.975	1.977	0.000	-4.000
1	5	0.223	-6.052	6.056	0.007	-6.026
2	-	0.032	-13.538	13.538	-	-
2	1	0.087	-2.043	2.045	0.000	-4.000
2	3	-0.09	-2.981	2.982	0.000	-6.000
2	4	0.000	-1.000	1.000	0.000	-2.000
2	5	0.101	-5.026	5.027	0.009	-4.009
2	6	-0.05	-2.480	2.481	0.000	-5.000
3	-	0.032	-9.921	9.921	-	-
3	2	0.096	-3.019	3.021	0.000	-6.000
3	5	-0.17	-5.870	5.873	0.014	-5.016
3	6	0.118	-1.024	1.030	0.000	-2.000
4	-	-0.13	-9.158	9.159	-	-
4	1	0.102	-2.025	2.028	0.000	-4.000
4	2	-0.00	-1.000	1.000	0.000	-2.000
4	5	-0.23	-6.128	6.132	0.009	-8.000
5	-	0.012	-0.018	0.022	-	-
5	1	-0.21	0.026	0.217	0.007	-6.026
5	2	-0.09	1.017	1.021	0.009	-4.009
5	3	0.192	0.854	0.876	0.014	-5.016
5	4	0.241	-1.926	1.941	0.009	-8.054
5	6	-0.13	0.012	0.130	0.009	-6.026
6	-	0.075	-9.543	9.543	-	-
6	2	0.057	-2.520	2.520	0.000	-5.000
6	3	-0.11	-0.976	0.983	0.000	-2.000
6	5	0.139	-6.039	6.040	0.009	-6.026
Total loss					0.049	-52.130

For Line flows and losses Results of Newton Raphson method show that the total line loss active power is 0.934 MW and the total line loss reactive power is

-53.361 MVAR.

Line flows and losses by Fast Decoupled Method

Table 9: Line power flow and line power loss by Fast Decoupled Method

From line	To line	MW Bus	MVAR Bus	MVA Bus	Mw Line loss	MVAR Line loss
1	-	0.032	-9.991	9.992	-	-
1	2	-0.087	-1.957	1.959	0.000	-4.000
1	4	-0.102	-1.975	1.977	0.000	-4.000
1	5	0.223	-6.052	6.056	0.007	-6.026
2	-	0.032	-13.538	13.538	-	-
2	1	0.087	-2.043	2.045	0.000	-4.000
2	3	-0.096	-2.981	2.982	0.000	-6.000
2	4	0.000	-1.000	1.000	0.000	-2.000
2	5	0.101	-5.026	5.027	0.009	-4.009
2	6	-0.057	-2.480	2.481	0.000	-5.000
3	-	0.032	-9.921	9.921	-	-
3	2	0.096	-3.019	3.021	0.000	-6.000
3	5	-0.178	-5.870	5.873	0.014	-5.016
3	6	0.118	-1.024	1.030	0.000	-2.000
4	-	-0.135	-9.158	9.159	-	-
4	1	0.102	-2.025	2.028	0.000	-4.000
4	2	-0.000	-1.000	1.000	0.000	-2.000
4	5	-0.232	-6.128	6.132	0.009	-8.000
5	-	0.012	-0.018	0.022	-	-
5	1	-0.215	0.026	0.217	0.007	-6.026
5	2	-0.091	1.017	1.021	0.009	-4.009
5	3	0.192	0.854	0.876	0.014	-5.016
5	4	0.241	-1.926	1.941	0.009	-8.054
5	6	-0.130	0.012	0.130	0.009	-6.026
6	-	0.075	-9.543	9.543	-	-
6	2	0.057	-2.520	2.520	0.000	-5.000
6	3	-0.118	-0.976	0.983	0.000	-2.000
6	5	0.139	-6.039	6.040	0.009	-6.026
Total loss					0.049	-52.130

The difference between the Results of Newton Raphson method and the Results of Gauss Seidal method and Fast decoupled method because the Newton Raphson method is more accurate as Maximum Power Mismatch is the lowest by 0.00029234 as shown in Figure 6.

3- Charts show a comparison between the three methods for power flow study for hybrid system

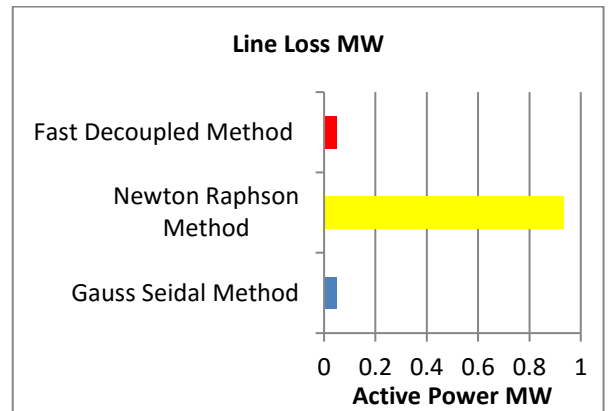

Figure 3: Line loss of the Power Flow Study Methods

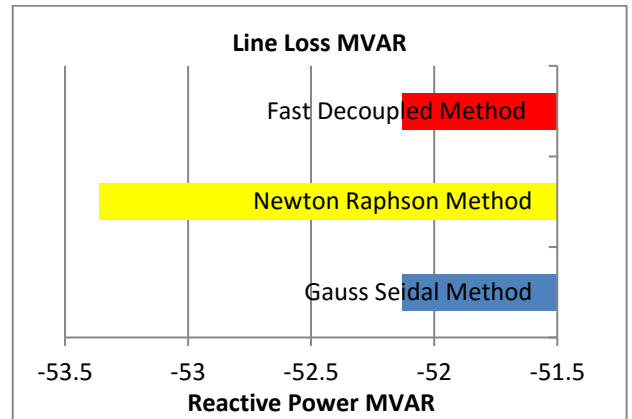

Figure 4: Line loss of the Power Flow Study Methods

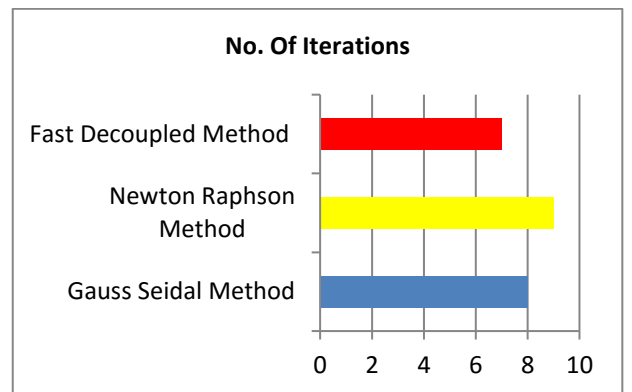
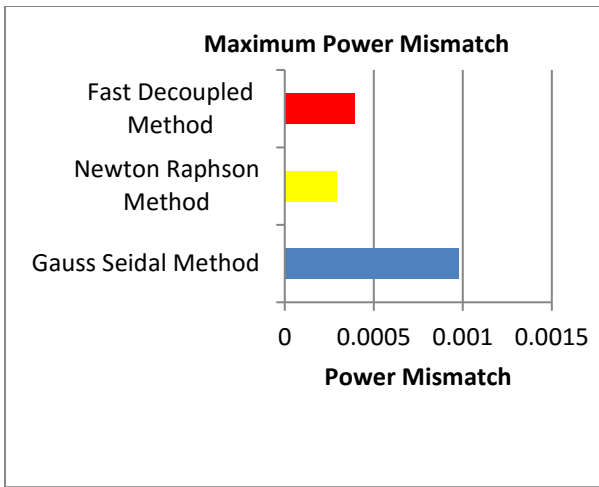
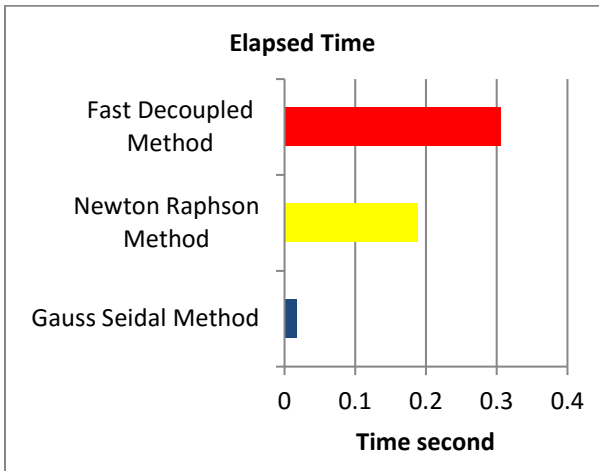

Figure 5: Number of Iterations of the Power Flow Study Methods





**Figure 6: Maximum Power Mismatch of the Power Flow Study Methods**



**Figure 7: Elapsed Time of the Power Flow Study Methods**

Figures 3, 4, 5, 6, 7 illustrates a comparison between different among power flow study methods.

Convergence used to determine speed at which power flow reaches its solution. The convergence is determined by plotting a chart between the maximum power mismatch and the number of iterations. Figure 8 shows the comparison of each Load Flow Study Methods.

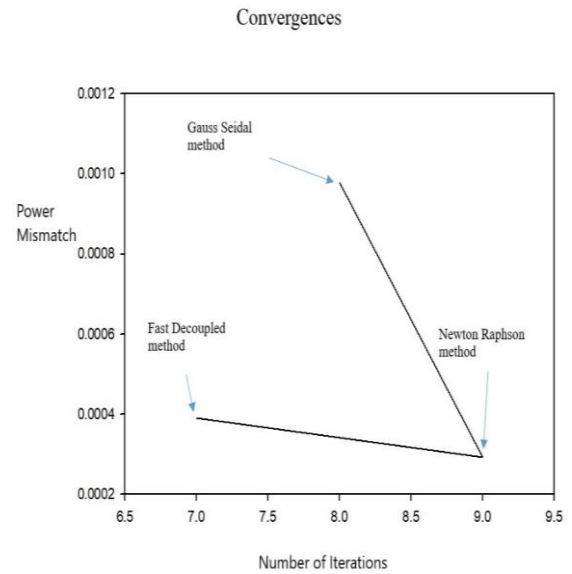

**Figure 8: Convergences of the Load Flow Study Methods**

## 5. CONCLUSION

Power flow or load-flow studies are essential for both planning future power system expansion and deciding procedures to make better operating systems. The magnitude and phase angle of the voltage at each bus, as well as line loss active and reactive power the line loss in each bus are the features showing the microgrid is achieving more security and stability.

All the simulation are carried out by using Matlab and applied to IEEE 6-bus at steady state condition with the tolerance values used for simulation are 0.001 and 0.1. The time for iterations in Gauss Seidal increases as the number of buses increases. The effective and most reliable amongst the three load flow methods is the Newton Raphson method because it converges fast, and its calculations are more accurate. Gauss Seidal method has the slowest convergence.

As for line losses the following remarks are concluded:

- According to the Results of Gauss Seidal method and Fast decoupled method the highest line loss is between two buses; bus 3 which is connected to the wind turbine and bus 5 which is connected to the load power, so the hybrid system designer should increase the wind turbine capacity to compensate line losses.
- According to the Results of Newton Raphson method the highest line losses is between two buses; bus 2 which is connected to the power load and bus 4 which is connected to the Photo-voltaic generator, so the hybrid system designer should increase the

Photovoltaic generator capacity to compensate line losses.

For small hybrid power systems with less computational complexity Gauss Seidel method can be the ideal method used for power system planning. The comparison between different power flow study methods reveals that Newton Raphson method has the fastest rate of convergence among the others numerical methods. Newton Raphson has easy calculations and is simple to execute, but as the number of buses increase, the number of iterations increases.

## 6. REFERENCES

- [1] Elgerd, O.L. "Electric Energy Systems Theory: An Introduction". 2nd Edition, (2012) Mc-Graw-Hill.
- [2] Kothari, I.J. and Nagrath, D.P. "Modern Power System Analysis" 3rd Edition, (2007) New York.
- [3] Olukayode A. Afolabi, Warsame H. Ali, Penrose Cofie, John Fuller, Pamela Obiomon, Emmanuel S. Kolawole "Analysis of the Load Flow Problem in Power System Planning Studies "Energy and Power Engineering, SciRes. (September 2015), PP 509-523.
- [4] S. Ghosh and D. Das, "Method for Load-Flow Solution of Radial Distribution Networks," Proceedings IEE Part C (GTD), vol.146, no.6, pp.641 – 648, 1999.
- [5] D.C. Idoniboyeobu, B. E. Nemine "Electrical Load Flow Studies for Efficient Power Supply In Bayelsa Stateusing Newton Raphson Technique" International Journal of Research in Engineering Technology — Volume 2 Issue 5, Sep - Oct 2017,ISSN: 2455.
- [6] Keyhani, A., Abur, A. and Hao, S. "Evaluation of Power Flow Techniques for Personal Computers". IEEE Transactions on Power Systems, (1989), PP 817-826.
- [7] Dharamjit, D.K.Tanti "Load Flow Analysis on IEEE 30 bus System" International Journal of Scientific and Research Publications, Volume 2, Issue 11, November 2012 ISSN 2250-3153.
- [8] Glover, J.D. and Sarma, M.S. "Power System Analysis and Design". 3rd Edition, (2002) Brooks/Cole, Pacific Grove.
- [9] Stott, B. "Review of Load-Flow Calculation Methods" Proceedings of the IEEE, (1974) PP 916-929.
- [10] Adejumbi, I.A., et al. "Numerical Methods in Load Flow Analysis: An Application to Nigeria Grid System". International Journal of Electrical and Electronics Engineering (IJEEE) (2014).
- [11] Dung VO TIEN , Radomir GONO , Zbigniew LEONOWICZ , Petr KREJCI " Load Flow Analysis in Power System Network Incorporating STATCOM: A Comparison of the Direct and Indirect Algorithm of the Newton-Raphson Method" power engineering and electrical engineering Volume:17 ,Number 1, March 2019.