

Analysis Study for the Benefits of Heavy Crude Oil Hydrotreating Before Distillation

Osman, W. S.^{a*}, Shoaib, A. M.^a, Ng, D. K. S.^b

^a Department of Petroleum Refining and Petrochemical Engineering, Faculty of Petroleum and Mining Engineering, Suez University, Suez, Egypt

^b School of Engineering & Physical Sciences, Heriot-Watt University, Malaysia.

*Corresponding author: Walaa.Osman@pme.suezuni.edu.eg

Article Info

Received 23 Nov. 2021

Revised 6 Dec. 2021

Accepted 17 Dec. 2021

Keywords

heavy crude oil, hydrotreating process, upgrading, process simulation.

Abstract

Heavy crude oils contain considerable amounts of contaminants (e.g., sulfur, nitrogen, and heavy metals) and asphaltenes. The high contents of such contaminants in crude oil would decrease the efficiency of the refining process at the distillation column and lead to various problems such as air pollution, corrosion, and catalyst poisoning. Viewing such difficulties, the objective of this paper is to study the effect and performance of the hydrotreating process of heavy crude oil before atmospheric distillation. Such a process is expected to improve the properties of heavy crude oil and consequently increase the efficiency of the refining process. Process simulation of such process was performed via ASPEN HYSYS V.9., based on an existing Egyptian refinery plant with a feedstock of (50/50% mixture of light and heavy Arabian crudes). The process simulation results showed that a significant improvement had been achieved in the characteristics of crude oil after the hydrotreating process (e.g., lower contaminants content, lower density, and higher yield of middle distillates).

Introduction

The change in the quality of crude oil around the world has affected the performance of oil refining industry significantly. Consequently, soon, oil refineries will have to replace light crude oil by heavy/extra-heavy crude oils as feedstock. Therefore, most of the existing and new refineries must be re-configured and designed to handle heavier feedstock. Such feedstock is characterized with low American Petroleum Institute (API) gravity, large amounts of impurities (sulfur (S), metals, nitrogen (N), asphaltenes), high viscosity and low distillate yields, making such feedstock more difficult to be processed compared to light crude oils. Conversely, the demand of light distillates for the production of clean fuels (e.g., ultra-low sulfur diesel and gasoline) is increasing worldwide [1].

Hydroprocessing is considered as a common process for removing S, N, and metal impurities from crude oil and distillates. Hydroprocessing includes mainly hydrodemetallization (HDM), hydrosulfurization (HDS) and hydrodenitrogenation (HDN) processes. Note that hydroprocessing reduces the impurities significantly. Meanwhile, the contents of Conradson carbon residue (CCR) and asphaltenes are also reduced. Therefore, such a process can improve the quality of heavy feedstock for fluidized catalytic cracking (FCC), residue catalytic cracking (RCC) and hydrocracking unit (HCR) [2].

Few studies have been conducted to evaluate the performance and challenges of hydrotreating process of crude oil [3]. Hydrotreating is widely applied on feedstock, from naphtha to reduced crude distillation products, but not applicable for the whole crude oil before distillation processes [4].

The crude oil hydrotreating process considers a major and hard challenge compared to hydrotreating of distillation fractions. This is due to the existence of many complex compounds and compositions, as well as multiple phases in crude oils. The presence of these complex molecules creates significant practical limitations during catalytic upgrading, causing poisoning and deactivation of catalysts. In final products, these heteroatom-containing compounds may cause other problems, including storage instability and discoloration. Furthermore, because of environmental constraints, future transportation fuels will not contain any type of heteroatoms, or at least much lower contents than in current fuel [5, 6].

Crude oil hydrotreating is a catalytic process in which heavy oils react with hydrogen over a selective catalyst under high pressure and temperature to break down sulfur, nitrogen, and metals from the oil. In addition, this process is used for partial saturation of polynuclear aromatic rings to reduce the carbon residue, it increases the quality and quantity of the distilled petroleum products. Besides,

high molecular weight compounds will be partially cracked and saturated with hydrogen to yield distillate fractions with increased hydrogen to carbon (H/C) ratio and low impurity content [3, 7].

In the past decades, hydroprocessing of crude oil has been presented in the literature. In 2001, Maya heavy crude oil was catalytically hydrotreated by Jorge Ancheyta in a high-pressure fixed bed pilot plant [8]. In 2011, researchers from the University of Bradford, UK proposed a method for increasing the productivity of the middle distillates, gasoline, jet fuel, and diesel fuel in a refinery by catalytic hydrotreating (HDT). Multiple reactions were performed in a continuous flow isothermal trickle-bed reactor using Iraqi crude oil as a feedstock and commercial cobalt-molybdenum on alumina (Co-Mo/-Al₂O₃) as a catalyst for a range of reactor temperatures, hydrogen pressures, and liquid hourly space velocities, with a constant hydrogen to oil ratio [9].

In this work, the hydrotreating process of crude oil was evaluated as a new technology used to improve the quality of crude oil and its products. The improvement in the behavior of hydrotreated oil is discussed. A comparison between the characteristics of distillation fractions of hydrotreated oil and those of conventional arrangement (distillation of crude oil firstly then hydrotreating of each product separately) has been introduced. An Egyptian refinery plant is taken as a case study in this work to perform the intended comparisons.

Process Simulation Model

An Egyptian refinery plant is taken as a case study. It is simulated using ASPEN HYSYS V.9. The results are then compared with the conventional arrangement of refinery plant. In this simulation model, two simulation fluid packages are selected, which are Peng-Robinson EOS (Equation of State) and REFSRK (Refinery Soave Redlich Kwong). For oil, gas and petrochemical applications Peng-Robinson EOS is generally the recommended property package. It predicts properties of mixtures ranging from well-defined light hydrocarbon systems to complex oil mixtures and provides optimized state equations for the rigorous handling of hydrocarbon systems [10]. Meanwhile, REFSRK fluid package is more suitable in hydroprocessing bed calculations. The simulated results are then validated through the published crude oil hydrotreating unit pilot plant presented by Jarullah [3] which nearly has similar properties as the feedstock of this study. Next, the simulation is used as the basis to analyze the performance of an Egyptian refinery plant with its feedstock (50/50% mixture of light and heavy Arabian crudes).

Model Validation

The case study in Jallura et al. [3] is used to validate the simulation model based on the existence of crude oil hydrotreating reactor. According to Jallura et al. [3], Iraqi crude oil was used as the feedstock for this pilot plant with commercial cobalt-molybdenum on alumina

(Co-Mo/g-Al₂O₃) as a catalyst in a trickle bed reactor for the hydrotreating (HDT) processes.

Note that the properties of the hydrotreated crude oil in the simulated model are compared with the result presented in Jarrulla et al. [3], and the results were in a good agreement. The results of simulated conventional atmospheric distillation unit and hydrotreating units of crude oil products were validated with the data extracted from an Egyptian refinery plant located in Alexandria which use a 50/50% mixture of light and heavy Arabian crudes as a feedstock (the case study). The comparison between the products specifications of the simulated model and the actual refinery plant gave results with a good agreement. Therefore, the proposed simulation model can be used to evaluate the performance of the process.

Case study

An Egyptian conventional refinery plant located in Alexandria is used to demonstrate the benefits of hydrotreating or hydroprocessing of the heavy crude oil feedstock before the conventional atmospheric distillation unit. In this case study, two feedstocks are analyzed, which are light Arabian crude oil and heavy Arabian crude oil, with API gravity 34.4, and 27.76 respectively.

In this existing plant in the industry, a 50/50% mixture of light and heavy Arabian crudes is used as a feedstock to the atmospheric distillation unit to overcome the problems of processing the heavy crude oil and trying to improve the quantity and quality of the middle distillates. In this conventional plant, several hydrotreating units are required to reach the products, such as naphtha, kerosene, and diesel within specifications.

This case study is chosen for illustration of this proposed work. This is a good example to clarify the change in crude productivity and products purity between this conventional arrangement of refinery processes and the newly suggested arrangement of refinery processes (hydrotreating for crude before distillation). The properties of the new mixture (50/50 % of light and heavy Arabian crudes) were generated in ASPEN HYSYS V.9 and the results are in Table 1.

The hydrotreating crude oil process was done at the optimum operating conditions (400 °C, 10 MPa of H₂ p.p., and 0.5 h⁻¹ LHSV) which are able to achieve maximum conversion of S, N, V, Ni and Asph [11].

Table 1: Properties of 50/50% mixture of light and heavy Arabian crudes.

Properties	Overall
Molecular Weight	225.2
SP.GR (60/60)	0.8720
API	30.77
Pour Point (°C)	11.73
Act. Volume Flow (m3/h)	664.0
Kinematic Viscosity (cs)	67.07
Viscosity (cp)	58.36
Reid VP at 37.8 °C (kPa)	54.69
True VP at 37.8 °C (kPa)	107.7
Nitrogen Content (ppmwt)	2823
Sulfur wt. (%)	2.34
Asphaltene Content (%)	0.64
Conradson Carbon Content(%)	5.53
Nickel Content (ppmwt)	12.43
Vanadium Content (ppmwt)	42.47
Olefins by Weight (%)	---
Paraffins by Weight (%)	22.92
Naphthalenes By Volume (%)	23.12
Aromatics by wt. (%)	53.96
Acidity (mg KOH/g)	9.433e-002
C to H Ratio	14.84
TBP 0% (°C)	-172.0
TBP 5% (°C)	51.41
TBP 10% (°C)	97.73
TBP 30% (°C)	209.1
TBP 50% (°C)	327.2
TBP 70% (°C)	479.7
TBP 90% (°C)	653.9
TBP 95% (°C)	720.0
TBP 100% (°C)	899.4

The reactions of the process were done at a continuous flow isothermal trickle-bed reactor with a commercial cobalt-molybdenum on alumina (Co-Mo/-

Al₂O₃) as a catalyst. By using the optimum ratio of LR/DR = 2.661, the reactor diameter was calculated to be 8.59 m, with catalyst loading of 590300 kg, and 0.335 catalyst void fraction for hydroprocessor bed used in crude oil hydrotreating process simulated model.

As shown in Figure 1, the process starts with the crude hydrotreating section, which constructed under the conditions indicated above. Next, the hydrotreated crude oil is fed to atmospheric distillation unit to produce the petroleum fractions (e.g., naphtha, kerosene, and diesel). Figure 2 shows the main distillation section of hydrotreated crude oil in this process; where kerosene and diesel are separated as side products and atmospheric residue is separated from the bottom of the main distillation tower. The vapor product is then separated at the top of main distillation tower and enter overhead section of distillation unit in process simulation as shown in Figure 3 to separate light petroleum products; LPG (Liquefied Petroleum Gases) and naphtha through debutanizer column. Note also that any remaining off gases are removed in overhead section.

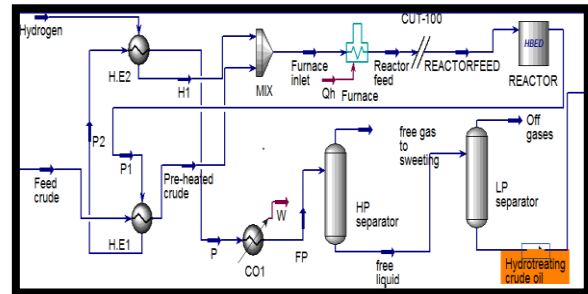
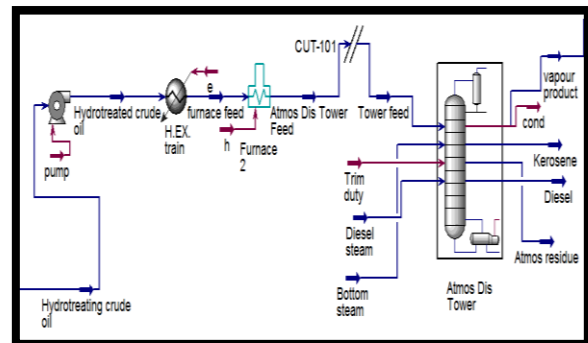
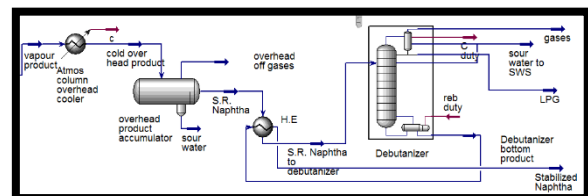
**Figure 1:** Hydrotreating section of simulation model flow diagram for the Egyptian refinery plant.**Figure 2:** Main distillation section of hydrotreated crude oil in process simulation model flow diagram.**Figure 3:** Overhead section of distillation unit in process simulation model flow diagram.

The basic data used for solving the main distillation tower of atmospheric distillation unit and the debutanizer column in overhead section of distillation unit are presented in Tables 2.

Table 2: Specification values used for solving towers of distillation unit for the process simulation model.

Specs value for main distillation tower	
Condenser temperature ° C	130.9
Reflex ratio	2.578
Over flash m ³ /h	23.19
Kerosene side stripper product flow kg/h	89790
Kerosene side stripper boil up ratio	0.5897
Pump around 1 flow rate m ³ /h	132.5
Pump around 1 Δ t ° C	37
Pump around 2 flow rate m ³ /h	251.7
Pump around 2 Δ t ° C	46
Diesel side stripper product flow rate kg/h	122900
Vapor product flow rate kg/h	149000
Bottom product flow rate kg/h	224100
Specs value for debutanizer column	
Reflex ratio	3
Condenser temperature ° C	54.01
Initial boiling point of naphtha product ° C	27.72
Overhead vapor flow rate kg/h	0.003256
Distillate rate kg/h	5939
Bottom product flow rate kg/h	133700

Results & discussions

The main purpose of crude oil hydroprocessing is to improve the quality of crude oil by removing impurities as well as improving the quantities and quality of the middle distillates. Heavy crude oils consist of many impurities that can significantly affect upon the properties of the final products and the efficiency of refining processes. The efficiency of desulfurization, denitrogenation, demetallization and deasphaltenization is measured by the degree of sulfur, nitrogen, metals and asphaltene removals, respectively.

Sulfur weight percent and nitrogen content have been reduced significantly in crude oil after the hydrotreating process; the percent removal of sulfur and nitrogen reach 98.05 and 92.02 respectively at reactor conditions [hydrogen consumption of 55900 m³/h (at standard condition), pressure drop of 49.53 kpa, and 400 °C WABT (weight average bed temperature)]. The results showed a great enhancement in the characteristics of crude oil after the hydrotreating process as well as for distillation products produced from hydrotreated crude oil. The change in the characteristics of crude oil after the hydrotreating process can be observed, as indicated in Table 3.

Table 3: Comparison between crude oil properties before and after hydrotreating process.

Properties	Crude oil before hydrotreating	Crude oil after hydrotreating
SP.GR (60/60)	0.8720	0.8283
API	30.77	36.32
Molecular Weight	225.2	188.0
Act. Volume Flow (m ³ /h)	663.2	676.0
Watson K	11.51	11.85
Kinematic Viscosity (cs)	67.07	10.41
Viscosity (cp)	58.36	8.275
Reid VP at 37.8 ° C (kPa)	54.68	41.20
True VP at 37.8 ° C (kPa)	107.7	50.21
TBP 0% (° C)	-172	-158.1
TBP 5% (° C)	51.41	36.52
TBP 10% (° C)	97.73	53.57
TBP 30% (° C)	209.1	171.9
TBP 50% (° C)	327.2	302.3
TBP 70% (° C)	479.7	413.1
TBP 90% (° C)	654.0	611.2
TBP 95% (° C)	720.1	627.6
TBP 100% (° C)	899.4	699.9
Mean Average Boiling Point (° C)	285.1	251.0
Vanadium Content (ppmwt)	42.47	0.0000
Sulfur wt (%)	2.34	0.03
Nitrogen Content (ppmwt)	2823	330.5
Nickel Content (ppmwt)	12.43	0.0000
Asphaltene Content (%)	0.64	0.00
Cloud Point (° C)	196.2	55.21
Freeze Point (° C)	-0.6558	-23.88
Conradson Carbon Content (%)	5.53	0.00
Softening Point (° C)	38.00	38.00
Paraffins by wt. (%)	22.92	38.67
Naphthenes by wt. (%)	23.12	20.78
Aromatics by wt. (%)	53.96	40.55
C to H Ratio	14.84	6.760

As shown, the density of the treated crude oil became lower as the specific gravity of hydrotreated crude decreased, and values of API and Watson K

increased. The hydrotreated crude oil became more valuable due to some hydrocracking during hydrotreating process, which results in conversion of some heavy compounds to lighter compounds. Hence, it is noted that the crude oil average molecular weight is decreased, while the volume flow rate is increased and hence, crude productivity is consequently increased.

The viscosity of crude oil is also decreased significantly after hydrotreating process, leading to easy handling and transport during manufacturing processes. Such observed phenomena are mainly due to olefins and aromatics saturation during hydrotreating processes. Enough time for the saturation process causes conversion of a large part of olefins and aromatics into saturated compounds, such as paraffins and cycloparaffins that have lower viscosity and density. Additionally, some heavy compounds of crude oil are converted into light compounds due to cracking of the bonds for heavy compounds [12].

Moreover, cloud point and freezing point are also reduced due to cracking of long chain paraffins. This has then facilitated the handling and storage of the hydrotreated crude oil at lower temperature.

Sulfur wt.%, and nitrogen content are also reduced significantly as mentioned above. This leads to a decrease in the percentage of impurities in the resulted crude oil; it also reduces its negative impact on the environment. In addition, equipment corrosion, catalysts poison in conversion processes and specifications deterioration of the final products are also reduced. It is worth to mention that nitrogen content reduction is preferred due to their considerable negative effects, because they cause catalyst poisoning in catalytic reactors in refinery conversion processes. Also, it has toxic effects on the storage and color stability of crude oil products [13, 14]. The highest removal of vanadium and nickel content is observed during the process due to the increasing destruction of large molecules, especially heavy molecules that contain a large amount of metals.

All asphaltene content and Conradson Carbon Residue were calculated as zero for hydrotreated crude oil in the results of hydroprocessing bed. Moreover, the carbon to hydrogen (C/H) ratio and coke deposit were decreased during manufacturing processes, especially on catalysts surface. Thus, this prevents rapid deactivation for the catalyst. This is due to the decomposition of larger molecules into smaller molecules that make easier diffusion within the catalyst during HDA reactions occur [3].

Crude oil structure has been changed due to the hydrocracking and saturation reactions, so it causes an increase in paraffins percent, while a decrease in naphthenes and aromatics is noticed. It is worth to note that mean average boiling point of the crude oil is decreased after hydrotreating process. This appears in true boiling point (TBP) analysis of hydrotreated crude oil; This results from the conversion of high boiling point compounds (such as those contained in

the residue fraction) into lighter molecules which give a clear indication of the increased yield improvement.

Note also that the values of true and Reid vapor pressure as well as the initial boiling point of crude oil are declined after hydrotreating process, contrary to the expected. The reason for this, is that a large amount of gas is released in both high- and low-pressure separators after crude hydrotreating process to recover the hydrogen gas for re-use in the hydrotreating process. This remark confirms that the amount of the exit off gases in overhead section of distillation unit after crude hydrotreating unit is equal to zero, as calculated by the simulation model. Hence, the disappearance of some devices in overhead section of distillation unit after crude hydrotreating unit was noticed such as the compressor followed by a cooler, three phase separator, and a mixer; this equipment was used to separate and re-contact the amount of naphtha released with off gases in overhead section of conventional distillation unit. It is expected that the fixed cost of the suggested configuration would be lower than that of the conventional configuration.

The hydrotreated crude oil was distilled into liquefied petroleum gas (LPG) and stabilized naphtha drawn from overhead section of distillation unit, kerosene, diesel, and atmospheric residue drawn from the main distillation column. As shown in Table 4, naphtha, kerosene, and diesel fractions productivity increase when the crude oil is hydrotreated before distillation, with a decrease in the proportion of atmospheric residue. The increasing of the middle distillates is due to conversion of heavy and long molecules that are concentrated in heavy fractions (like atmospheric residue) to light compounds.

Table 4: Effect of hydrotreating crude oil process on oil fractions productivity.

Products	wt. % in origin crude	wt. % in hydrotreated crude
LPG	1.479	1.031
Naphtha	17.431	23.199
Kerosene	8.531	15.580
Diesel	18.489	21.325
Residue	54.011	38.885

The main properties of all oil fractions produced by the separation of hydrotreated crude oil are improved such as:

- The specific gravity (SP.GR) of the oil fractions produced in the current study is lower than the same fractions produced in conventional units, giving a great indication of progressive productivity improvement of these fractions.
- Oil fractions flash point is increased and pour point is decreased leading to easy transportation and storage.
- All impurities (S, N, Ni, and V) are reduced due to high removal percent of these impurities from crude oil during hydrotreating process as indicated

above. Thus, the simulation neglected its values. The whole crude itself after hydrotreating process has about 0.03% of sulfur, 0.03305% of nitrogen, and 0.00% of both nickel and vanadium

Table 5 show the properties improvement of LPG produced from hydrotreated crude distillation with nearly the same composition of LPG produced from conventional crude distillation unit.

Table 5: Comparison between properties of LPG produced by conventional and suggested methods.

Properties	LPG produced from conventional crude distillation unit	LPG produced from hydrotreated crude distillation unit
Molecular Weight	54.17	53.90
API	124.8	123.9
SP.GR (60/60)	0.5522	0.554
Act. Volume Flow (m ³ /h)	16.25	11.77
Watson K	14	13.94
Partial Pressure of H ₂ S (kPa)	0.0000	2.862
Reid VP at 37.8 °C (kPa)	781.9	682.3
True VP at 37.8 °C (kPa)	986.9	776.2
Acidity (mg KOH/g)	1.649e-005	0.0000
Flash Point (°C)	-83.54	-82.5
Freeze Point (°C)	-156.8	-154.8
Mean Average Boiling Point (°C)	-15.73	-23.15
Nickel Content (ppmwt)	7.666e-003	0.000
Nitrogen Content (ppmwt)	0.1109	0.000
Olefins wt. %	0.00	0.0000
Paraffins wt. %	99.88	99.89
Pour Point (°C)	-135.5	-82.06
Sulfur Mercaptan wt. %	0.00	0.00
Sulfur wt. %	0.05	0.04
Vanadium Content (ppmwt)	2.478e-002	0.0000

Table 6 and Table 7 collected the properties of the other crude oil fractions produced with the

conventional method and that produced by separation of hydrotreated crude oil respectively.

From these two tables, it is clear that; the naphtha produced from distillation of hydrotreated crude has nearly the same density and mean average boiling point as the naphtha produced from naphtha hydrotreating unit in conventional units, with nearly the same fraction distillation analysis. Additionally, the impurities reduction has been achieved in both fractions. These results emphasize that the naphtha produced from hydrotreated crude distillation unit does not need any additional treatments before entering the reforming and isomerization units.

The cetane number (cetane rating) is an indicator of the speed of combustion of diesel fuel and the pressure required for ignition. The cetane index is a number that indicates the quality of diesel fuel, based on its density and volatility, and is approximately the same as the cetane number [15]. As shown in Table 8, the diesel produced from distillation of hydrotreated crude has higher cetane number than the diesel produced from conventional process. It is noticed also that cloud point is decreased; this indicates an improvement in the quality of a diesel fuel has been achieved.

The atmospheric crude residue has a boiling range above 350 °C and is mainly used as a feedstock to vacuum distillation units for the production of base oils as well as for the production of vacuum gas oil and lubricating oils under certain conditions. Besides, it is used as a fuel oil used in power plants, as fuel for furnaces and as a component of diesel oil [16].

After hydrotreating of crude oil directly before distillation, the characteristics of the crude residue produced are better than those of the crude residue generated by conventional processes as follows:

The density and viscosity of crude residue are lower than those found in crude residue generated by conventional methods, which results in easy flow at lower temperatures and gives an indication of increasing the light fractions. Therefore, residual fuel oil generated by a conventional method is less useful because it is so viscous that it must be heated with a special heating system before using it, additionally, it has large contaminants compared to this study, thus producing a good fuel oil with higher specific heat. Power plants and large ships can use residual fuel oil produced by hydrotreated crude oil directly without any treatment.

The saturation of olefins and aromatics during the hydrotreating process causes great reduction in the density of crude residue due to production of saturated compounds, such as paraffins and cycloparaffins which have low density. Moreover, a part of these compounds is converted to light compounds due to the cracking of the bonds for heavy compounds, which have a long chain and high density and viscosity [12, 16, 17]. This explains the reduction in the final boiling point and viscosity of crude residue produced by hydrotreated crude oil.

Table 6: Properties of crude oil fractions produced by conventional methods.

Properties	Oil fractions				
	Naphtha	Naphtha from naphtha hydrotreating unit	Kerosene	Diesel	Atmospheric residue
SP.GR (60/60)	0.7305	0.7186	0.7948	0.8476	0.9741
API	62.21	65.42	46.52	35.44	13.77
Molecular Weight	104.2	96.56	160.7	226.6	470.8
Act. Volume Flow (m ³ /h)	153.1	222	81.39	161.1	411.8
Watson K	12.10	12.05	11.95	11.82	11.55
Kinematic Viscosity (cs)	0.4278	0.2419	0.3327	0.4451	1.187
Viscosity (cp)	0.281	0.1679	0.2013	0.2948	0.8982
Reid VP at 37.8 °C (kPa)	27.28	265	0.3365	6.185e-002	
True VP at 37.8 °C (kPa)	27.63	459.3	0.3417	6.530	
Mean Average Boiling Point (°C)	106.9	86.97	199.4	281.4	510.1
D86 IBP (°C)	58.96	--	129.7	134.9	257.9
D86 5% (°C)	65.48	39.46	183.6	244	355
D86 10% (°C)	73.79	50.77	185.9	248.6	372.2
D86 30% (°C)	97.16	78.1	191.1	260	435.1
D86 50% (°C)	115.5	97.67	196.9	275.6	507.2
D86 70% (°C)	133.3	119.2	204.5	296.3	582.2
D86 90% (°C)	151.7	153.5	214.7	331.7	732.6
D86 95% (°C)	161	168	222.5	347.4	761
D86 FBP (°C)	183.7	183.9	247.7	375.8	859.6
Cloud Point (°C)	-100.8	-113.5	-41.3	-2.38	70.7
Flash Point (°C)			69.28	114.2	161.4
Nitrogen Content (ppmwt)	125.1	0.3561	181.9	230.2	5078

Sulfur wt.%	0.05	0.00004628	0.22	1.3	3.84
Nickel Content (ppmw)			0.2781	3.494e-002	21.59
Vanadium Content (ppmw)			0.8869	0.1085	74.04
Conradson carbon content (%)				0.06	10.21
Cetane Idx D4737				52.64	
Cetane Number D4737				55.84	

Table 7: Properties of crude oil fractions produced by separation of hydrotreated crude oil.

Properties	Oil Fractions			
	Naphtha	Kerosene	Diesel	Atmospheric residue
SP.GR (60/60)	0.7058	0.8058	0.8736	0.9528
API	68.99	44.11	30.47	17.00
Molecular Weight	98.21	176.6	285.4	489.7
Act. Volume Flow (m3/h)	212.1	147.1	186.5	313.1
Watson K	12.32	11.92	11.82	11.77
Kinematic Viscosity (cs)	0.3442	0.2465	0.3646	0.8986
Viscosity (cp)	0.2169	0.1504	0.2404	0.6432
Reid VP at 37.8 °C (kPa)	49.02	0.1410	1.464e-002	
True VP at 37.8 °C (kPa)	50.42	0.1409	6.484	
Mean Average Boiling Point (°C)	88.17	220.1	339.6	510.4
D86 IBP (°C)	27.72	140.7	117.5	273.4
D86 5% (°C)	56.57	200.2	298.6	379.6

D86 10% (° C)	59.83	201.7	302.7	384.8
D86 30% (° C)	72.65	206.2	317.3	417.6
D86 50% (° C)	99.88	210.5	331.6	544.0
D86 70% (° C)	130.6	221.1	363.7	572.2
D86 90% (° C)	153.6	252.6	377.5	608.1
D86 95% (° C)	161.8	264.4	388.9	622.6
D86 FBP (° C)	189.2	292.1	416.8	656.8
Cloud Point (oC)	-112.1	-37.88	-10.29	48.33
Flash Point (o C)		71.4	125.2	152.4
Nitrogen Content (ppmwt)	-----	-----	----	-----
Sulfur wt. %	----	-----	----	-----
Nickel Content (ppmwt)	0.000	0.000	0.000	0.000
Vanadium Content (ppmwt)	0.000	0.000	0.000	0.000
Conradson carbon content (%)			---	-----
Cetane Idx D4737			56.48	
Cetane Number D4737			61.97	

Furthermore, direct hydrotreating of crude residue requires additional processes and sever operating conditions because it contains heavy and complex compounds as well as high contaminants. Therefore, the used catalyst will be quickly deactivated due to plugging of the active sites of the catalyst due to coke deposition resulting in reduced efficiency of the HDT process [8].

One hydrotreating unit will replace two hydrotreating units in conventional refinery plant when applying the suggested simulated model for crude hydrotreating. Crude productivity of middle distillates will increase with high quality, reducing residue fraction and the residue fraction produced has high improved properties. As referred earlier due to the presence of HP separator and low-pressure separator nearly all light ends of crude separated before distillation process so, it was noticed that the disappearance of some devices in overhead section of distillation unit after crude hydrotreating unit. Certainly, that will reduce from fixed cost of the suggested simulated model compared to

conventional method. In addition, the utilities and devices used to purify and recycle the hydrogen used in hydrotreating process will decrease when apply one hydrotreating unit instead of two hydrotreating units.

Wissam Muhsin and Jie Zhang conducted an economic assessment of a crude oil hydrotreating process with a crude distillation unit, which was then compared to the conventional process, in which all hydrotreating processes are performed on each oil product. According to the comparison results, the total cost savings of hydrotreating crude oil before crude distillation is 47.32 percent, indicating that this process is superior to hydrotreating each oil product separately [18].

Conclusions

Hydrotreating the crude oil was carried out under optimal operating conditions (400 o C, 0.5hr-1 LHSV, 10 Mpa Hydrogen pressure) which gave maximum conversion of (S, N, V, Ni and Asph). The crude oil is

upgraded after hydrotreating process and the hydrotreated crude oil becomes more valuable and more purified by removing the impurities contents (mainly sulfur (S), nitrogen (N), asphaltene (Asph), vanadium (V) and nickel (Ni)).

The density of crude oil became lighter, the viscosity of crude oil has been decreased significantly; leading to easy handling and transport during manufacturing processes; the pour point has been reduced and will therefore facilitate the handling and storage of the hydrotreated crude oil at lower temperature.

Besides, it was found that the mean average boiling point of the crude oil is decreased, and the paraffins content of hydrotreated crude oil is increased, while naphthenes and aromatics are decreased.

Direct hydrotreating of crude oil can increase the yield of middle distillate fractions (transportation fuels) compared with the middle distillate produced by conventional methods with simultaneously improvement in the fuel's quality.

The properties of LPG produced from distillation of hydrotreated crude is improved with nearly the same composition of LPG produced from conventional crude distillation unit.

Naphtha properties produced from distillation of hydrotreated crude oil is nearly the same as that produced from naphtha hydrotreating unit in conventional plant if not better. So, it does not need any additional treatments before entering the reforming or isomerization units.

The diesel fraction produced from hydrotreated crude distillation unit has higher cetane number than the that produced conventionally, and cloud point is also decreased; this indicates that an improvement in the quality of a diesel fuel has been achieved; so, it does not need any additional treatments.

The specifications of crude residue produced by direct hydrotreating of crude oil are better than the specifications of crude residue produced by conventional processes. The contents of S, N, Ni, V and Asphs. of crude residue generated from hydrotreated crude oil are much lower compared to the contents of crude residue generated by conventional methods. The viscosity and density are also enhanced; so, the flow becomes easy at low temperatures.

Finally, the crude oil hydrotreating process can produce good fuel oils with high heating value. One hydrotreating unit of whole crude oil will replace two or more hydrotreating units in conventional refinery plant. Thus, it will improve the economics of hydrotreating process.

Funding sources

This research received no external funding.

Conflicts of interest

There are no conflicts to declare

References

- [1] J. Ancheyta, James G. Speight, Hydroprocessing of heavy oils and residua, Boca Raton, London, New York: Taylor & Francis Group, LLC, 2007.
- [2] J. Ancheyta, G. Betancourt, G. Marroquin, G. centeno, L.C. Castaneda, F. Alonso, J.A. Munoz, Ma.T. Gomez, P. Rayo, Hydroprocessing of Maya heavy crude oil in two reaction stages, Applied Catalysis A: General, 233(1-2) (2002) 159–170.
- [3] Aysar T. Jarullah, Kinetic modelling simulation and optimal operation of trickle bed reactor for hydrotreating of crude oil, Ph. D. Thesis, School of Engineering, Design and Technology University of Bradford: United Kingdom, 2011.
- [4] Aysar T. Jarullah, Iqbal M. Mujtaba, Alastair S. Wood, Kinetic model development and simulation of simultaneous hydrodenitrogenation and hydrodemetallization of crude oil in trickle bed reactor, Fuel, 90(6) (2011) 2165-2181.
- [5] Aysar T. Jarullah, Iqbal M. Mujtaba, Alastair S. Wood, Kinetic parameter estimation and simulation of trickle-bed reactor for hydrodesulfurization of crude oil, Chemical engineering science, 66(5) (2011) 859- 871.
- [6] Chang S. Hsu, Paul R. Robinson, Practical advances in petroleum processing, Vol. 2, Springer Science Business Media, Inc., 2006.
- [7] Richard H. Nielsen, Heavy oil hydrotreating, in Process Economics Program Report 214A, Menlo Park, California: SRI Consulting, Dec 01, 2007, IHS Inc., 2015.
- [8] J. Ancheyta-Juárez, G. Betancourt-Rivera, G. Marroquín-Sánchez, A. M. Pérez-Arellano, S. K. Maity, Ma. T. Cortez, R. del Río-Soto, An exploratory study for obtaining synthetic crudes from heavy crude oils via hydrotreating, Energy Fuels, 15(1) (2001) 120–127.
- [9] Brian Westenhaus, Generating More Fuel from Less Crude Oil, 21 January 2011. <http://oilprice.com/Energy/Crude-oil/Generating-More-Fuel-from-Less-Crude-Oil>
- [10] Abd. Hamid, Mohd. Kamaruddin, HYSYS: An Introduction to chemical engineering simulation for UTM Degree++ Program, Engineering, 2007. <https://api.semanticscholar.org/CorpusID:107772574>
- [11] Ahmed A. Bhran, Abeer M. Shoaib, Blessing Umana, Optimization of crude oil hydrotreating process as a function of operating conditions: Application of response surface methodology, Computers and Chemical Engineering, 89 (2016) 158–165.
- [12] Abdul Mun'em A. Karim, Abdul Halim A. Mohammed, Haider A. Areff, Effect of operating conditions on hydrodesulfurization of vacuum gas oil, Diyala Journal of Engineering Sciences, 01(01) (2008) 19-31.

[13] James G. Speight, The desulfurization of heavy oils and residues, 2nd Edition, New York, Marcel Dekker, Inc., 2000.

[14] Kaernbach W, Kisielow W, Warzecha L, Miga K, Klecan R, Influence of petroleum nitrogen compounds on hydrodesulphurization, Fuel, 69 (1990) 221–224.16.

[15] Dabelstein W., Reglitzky A., Schutze A., Reders K., Automotive Fuels, In: Ullmann's Encyclopedia of Industrial Chemistry, Wiley-VCH Verlag GmbH & Co. KGaA, Weinheim, 2007.

http://dx.doi.org/10.1002/14356007.a16_719.pub2

[16] Mahmood Sh, Abdul-Karim R, Hussein E M, Technology of oil and gas, Baghdad, Oil Training Institute, 1990.

[17] Abbas, A.S., Low sulfur feedstock from basrah reduced crude oil for coke production, Msc. Thesis, University of Baghdad, 1999.

[18] Wissam Muhsin, Jie Zhang, Economic Assessment of a Crude Oil Hydrotreating Process, Chemical Engineering Transactions, 76 (2019) 481-486.