



# An Overview in Protection Coordination Methods for Mitigation DGs Penetration in Distribution System

Adel Amer\*, Eid A. Gouda and Akram Elmitwally

## KEYWORDS:

*Distributed Generation (DG), Protection Coordination, Overcurrent Relay, Fault current limiter*

**Abstract**— This paper introduces an overview for the benefits of distributed generations (DGs) in many aspects related to reliability of distribution system. Also, introduce the issues developed in protection system regarding the penetration of (DGs) in distribution system. A review is introduced of different scenarios of coordination between the common protection devices such as overcurrent relays, fuses, reclosers in distribution system. Furthermore, a review of protection coordination scenarios that developed to mitigate the DGs penetration that divided into two scenarios, one of them with minimum change in protection system such as disconnect DG from network when fault happen, limits DG output current according to DG terminal voltage, and Optimal DG size and location. The other scenario introduces a modification in protection system component such as obtaining new relay coordination and limiting fault current levels. These scenarios are developed to obtain the protection system secure and reliable as before the penetration of DGs. A comparison between advantages and disadvantages of these scenarios in terms of cost, communication links are introduced. Also, a review of usage of fault current limiter device (FCL) as a practical solution to mitigate DGs penetration impacts in protection system.

## I. INTRODUCTION

**D**EVELOPING countries face many challenges regarding the reliability of electrical network which is below the acceptable levels that lead to enlarging the need of distributed generations (DGs). Besides

the desire of the consumers for a cheap and reliable energy source in comparison to the large generators, DGs penetration increased as they have smaller capacities, cheap operating costs, low environmental pollution, high efficiency, voltage profile improvement, and enhance the capacity of the electrical grid [1, 2].

Despite the huge benefits gained from the penetration of DGs, the large penetration leads to conflicts in the protection system of distribution systems as the design of distribution networks is a radial network, and penetration of DGs changes the nature of the network [2].

The protection system in the distribution network contains different types of protection devices such as overcurrent relays, and a combination of fuses, and reclosers. These devices are configured in the distribution network as the overcurrent relay is suited at the distribution system substations, reclosers are installed on main feeders, and fuses

Received: (15 October, 2021) - Revised: (08 December, 2021) - Accepted: (09 December, 2021)

\*Corresponding Author: Adel Amer, Researcher at Electrical Engineering Department, Faculty of Engineering, Mansoura University, (email: eng\_adelamer1990@yahoo.com)

Eid Abdelbaki Gouda, associate professor at Electrical Engineering Department, Faculty of Engineering, Mansoura University, (email: eaidgoda@mans.edu.eg)

Akram Elmitwally, professor at Electrical Engineering Department, Faculty of Engineering, Mansoura University, (email: kelmitwally@yahoo.co.uk)

are installed on laterals. Before the penetration of DGs, the coordination between these devices is ensured, but when DGs penetrated in the distribution system, radial system behavior is changed that leading to miscoordination between the protection devices [2]. The degree of miscoordination between protection devices depends on the capacity of DGs and their type and location [3, 4].

The negative impact from the DGs penetration is essentially generated from the increase in the level of fault current and the change of the direction that cause different issues in the protection of the distribution system like protection blinding, network islanding, false tripping, change in fault current levels, and change of voltage profile [5].

Regarding the DG penetration impacts, proper coordination between protection devices should be guaranteed. Therefore, many research studies developed solutions for these coordination problems in distribution systems regarding the DGs penetration.

In this paper, an overview is introduced regarding the negative impacts of DGs penetrations and coordination methods developed to mitigate these impacts to ensure the validity of the protection system after DGs penetration in the distribution system.

## II. DISTRIBUTED GENERATION IMPACT IN THE PROTECTION SYSTEM

Penetration of distributed generation produces many challenges for power system quality, stability, reliability, and protection system operation [6]. Negative impacts on the protection system may vary depending on the distribution system type and DG type that is used in the power system [6,7]. Particularly, the penetration of DGs in networks with meshed type largely modifies the magnitude and the direction of short circuit currents. In [8], DG type significantly affects fault current as synchronous generator type can feed large, sustained fault current while inverter-based type could be controlled so its output is limited to the nominal current.

The negative impacts from DGs penetration led to serious malfunction for the operation of the protection system and urge for change equipment in the power system with high cost. Also, leads to blocking feeder protection and miscoordination of protective relays. Miscoordination between relays may affect tripping feeders not related to the fault that leads to unnecessary interruptions for the power source. These negative impacts lead to reducing the distribution system reliability. Furthermore, miscoordination could delay the time of clearance for the fault that resulting in high stresses on the equipment where reduces the lifespan [9,10]. Regarding these issues, an urge for developing techniques to mitigate the negative impact to DGs penetration.

In the following section some of the practical issues obtained from DGs introduction in distribution system [5]:

### A. Increase Fault Current Level

The increase of fault current level due to single DG may be neglected, but for a large number of DGs, the effect in fault current level could be significantly high which in turn produce miscoordination between protection devices [11]. This miscoordination severely affects distribution system safety and reliability. On other hands, DGs penetration effect on the flow of fault current which be different from the original designed flow. The change in fault current depends on DGs capacity, technology, and point of connection in the distribution system.

### B. Reverse Power Flow

The design of a radial distribution system relies on the power unidirectional flow from the source side to the loads side. Regarding this design, protection schemes of distribution system use the directional overcurrent relays. Using DGs in the distribution system as a power source lead to modifying the direction of power flow which is considered as an issue in the protection system if it is excluded from the design of protection coordination [12].

### C. Sympathetic Tripping

False tripping is happened because of the ability of synchronous DG type to feed the sustained short circuit current [13]. This issue can be illustrated using Fig. 1 as the fault current occurs on feeder 1, but also feeder 2 trips because the DG is feeding the overcurrent.

Directional overcurrent relay is used as a solution for false tripping, but with considering these rules: First, Change the Bus protection to trip from the main infeed relays. Second, The directional overcurrent relay is too expensive than a non-directional one.

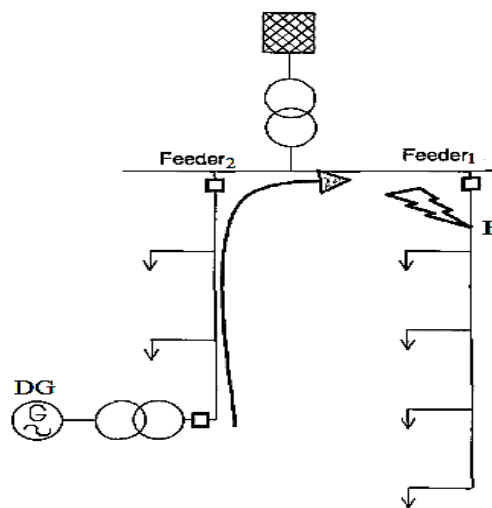

Fig. 1 False tripping Principle

### D. Fuse-Saving Disruption

Fuse saving scheme is used in the distribution system that protected with a recloser-fuse combination where recloser

operates quickly before the lateral fuses. This scheme is ensured as the recloser setting to be on a fast curve with a delay setpoint. Applying DGs downstream the fuse leads to changing the short circuit current to a higher value that led to fuse operation not being accurate [14].

#### E. Temporary Faults

Normally, in a radial distribution system, the fault current is produced from only one source where during the fault clearing process, this source breaker should be open. With the presence of DGs, the source of fault become multiple sources where during clearing the fault, all sources for the fault should be disconnected, so DG should be disconnected when fault happens and before the reclosing time passed. The DG disconnection could be faster or slower which may impact overcurrent protection and voltage restrictions. In this situation, DGs may prevent the reclosing process during temporary fault happens [3].

#### F. Islanding Issues

During island operation where the loss of utility connection from a part of the network, some issues face the protection system regarding the existence of DGs as follows:

Reconnection of utility to the islanded part could be complicated, especially when using automatic reclosing where leads to failure of equipment and negatively affect the reliability of the system.

The operator of the network may be unable to ensure the quality of the island due to abnormality in voltage, frequency, and the fault current level may decrease to lead to failure in overcurrent protection coordination.

### III. COORDINATION BETWEEN PROTECTIVE DEVICES IN THE DISTRIBUTION SYSTEM

Protection coordination aims to find the best timing between protection devices when an abnormal condition happens in the distribution system. Normally, the coordination is done with the help of log-log paper, but nowadays, the usage of computer-based analyzing is increasing.

Coordination is performed by dividing the distribution system by zones and if any fault occurred in any zone, the protection devices should act to clear the fault and disconnect the zone that is affected by the fault from the other zones. Proper overlapping should be maintained between all the network zones and prevent any zone not being protected [1].

Protection coordination aims to decrease the spread of the fault to minimize the number of consumers that could be affected, decrease service interruption due to faults, decrease the service outage by finding the location of faults. Depending on the protection devices that are commonly used in the distribution system, coordination between devices could be classified into the following:

#### A. Fuse-Fuse Coordination

To properly coordinate fuses, it is essential to ensure the main fuse maximum clearance time does not reach above 75 percent of the value of the backup fuse minimum melting time as shown in Fig.2 to ensure that the protecting fuse always clear the faults before the backup fuse (protected fuse) [40].

The coordination between fuses is achieved through using the time-current characteristics with help of log- log paper same as the help of computer-based assisting tools in overcurrent relays coordination to make the coordination between fuses much easier [40].

#### B. Fuse-recloser Coordination

The protection system is designed as the fuses are installed in remote positions far from the substation and the recloser installed near to the substation. So, during the occurrence of instantaneous fault upstream of the fuse, the fuse shouldn't operate as the recloser should remove the fault by reclosing operation much time. But when the fault is permanent, the fuse must operate and melt to clear the fault [41,42].

The fuse-recloser coordination problem is studied in many studies with the penetration of DGs in the network. In [23], an adaptive scheme was introduced to solve the protection coordination problem between fuses- reclosers combination in a radial distribution network with a massive presence of DGs. In [43], a new technique is applied to enlarge the penetration of DGs without changing the coordination for fuse-recloser in a radial distribution system.

Depending on the location of fuse-recloser to each other, the coordination can be varying. Whether the recloser location at the load side and then the fuse operation on the source side or vice versa as follows [40].

##### 1) Fuse installed at the Source

In this scenario, all the reclosers on wherein load side should operate before the fuse minimum melting time. Through using multiplying factors on the time-current curve of the recloser. These modifications in the recloser characteristics make it slower in operation but in the end, it should be faster than the fuse operation as shown in Fig.3.

The multiplying factor is chosen depending on the time of reclosing and the reclosing times. It is important to take care of the voltage level of the fuse and the recloser as if the fuse in the high voltage side and recloser in low voltage side of the power transformer, the curves of the reclosers and fuses should be transferred in horizontal direction regarding the axis of the current to cover the transformer turns ratio.

Usually, it is simple to transfer the fuse curve, depending on the tap of the transformer on the high voltage side that produces the highest current [40].

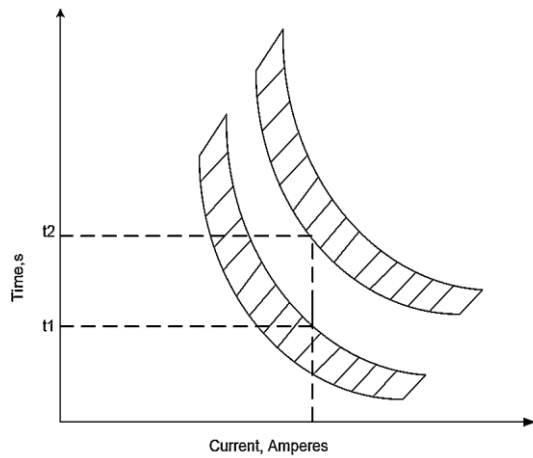

Fig.2. Fuse- Fuse time/current characteristics

2) Fuse installed at the Load

To design the protection coordination between the recloser and the fuse in case the fuse is on the load side, it should guarantee that the fuse minimum melting time is bigger than the fast curve of the recloser after multiplying with multiplying factor as shown in Fig.4.

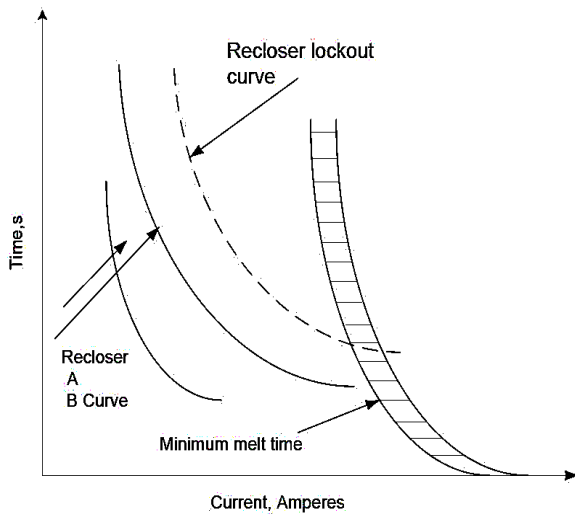

Fig.3 Source side fuse- Recloser time/current characteristics

Also, the maximum clearing time of the fuse should be less than the recloser curve without using the adding multiplying factor [40].

For better coordination between fuses and reclosers, the recloser setting should be 2 times instantaneous operations then 2 times of operation with delay. When the recloser operates for the first time, it usually clears 80 % of the faults that happen temporarily and for the second time, it clears around 10% of faults. fuses on the load side are operating before the third operation to clear the permanent faults.

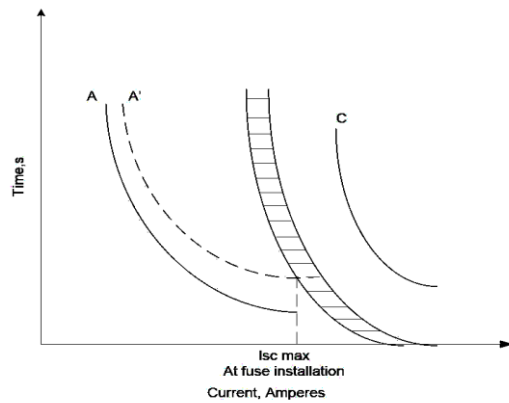

Fig. 4 Load side fuse- Recloser time/current characteristics

C. Relay-Relay Coordination

During fault time, each relay (Main& Backup) senses the fault, but the main relay should work first, and after a specific time the backup relay acts [44]. Fig.5 shows a radial system that is covered by two relays where if the fault happens at F, relay 2 should act first as it's the main where its operating time is less than the R1 which is considered the backup relay to guarantee selectivity in the protection system.

Proper coordination between overcurrent relays is needed to guarantee a reliable, simple, and secure protection system. The coordination is accomplished by finding each relay setting which is pickup current ( $I_{pickup}$ ) and time dial setting (TDS).

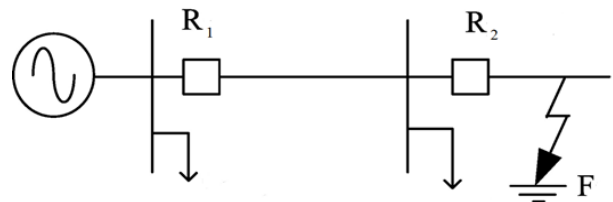

Fig.5 Radial system with protective relays

Many techniques are developed to find the coordination between overcurrent relays. These techniques are categorized into three types: trial-error techniques, topological techniques, and optimization techniques [45].

The trial- error technique is common in the past with a slow convergence because of its large iterations that are needed to find the suitable setting for relays. the mentioned behavior for the trial-and-error method leads to develop a breakpoint technique that breaks all loops to reduce the iterations number.

Topological techniques contain graph and functional methods to find the breakpoints. The solution obtained by this technique is considered the option settings best solution, but in any strict sense, it is not considered optimal. So, the TDS setting of the relay will be high. Also, the coordination problem is complex, So, the trial-error technique and topological technique are taking much time and not optimal solutions [40].

Some researchers classify the previous methods into three sections as follows, curve fitting method, graph theory, and optimization method [45]. The curve fitting is based on obtaining the finest function. The coordination of the overcurrent relay is defined using the polynomial. In graph theory, utilizing the system structure determines the minimum group of breakpoints. The optimization technique reduces the urge to get the group of breakpoints which makes it popular among researchers [44, 46].

In [47], the first researcher who applied optimization technique in directional overcurrent relays (DOCR) coordination problem and solved it as a nonlinear problem. Meta-heuristic methods are widely used to solve this problem include particle swarm optimization (PSO), genetic algorithm (GA), differential evolution (DE), harmony search (HS), artificial bees colony (ABC), honey bee algorithm (HBA), seeker optimization algorithm (SOA), and biogeography-based optimization. In [48], illustrated that the techniques regarding nature behavior are more suitable to solve complex problems. In [49, 50], the PSO technique is applied as a solver using the natural behavior of bird groups and fish schooling. ABC technique in [51] simulated the behavior of honey bee swarms and applied this algorithm to the 9-bus power system and found that the algorithm's exploration done very well but exploitation is not good enough where it suffered to look for the optimal solution. HBA technique in [52] is based on moving bees in the colony looking forward to the food where the proposed method enhances the performance of HBA by using a modified neighborhood search.

PSO algorithm is applied first in [53] to solve a nonlinear optimization problem. PSO is considered a popular solver for many application problems that use optimization to be solved. In [54] illustrated that PSO can be used to solve many power system problems. These problems are classified into linear programming (LP), nonlinear programming (NLP), and integer programming (IP). LP is applied to a problem categorized using linear equality and inequality constraints such as operation and planning, state estimation, economic dispatch, power flow, protection system coordination, and maintenance program schedule. IP is applied for cases where the variables' constraints are taken as integer values. Applications of IP in the power system are for security assessment, generation planning, transmission system design, loads management, and distribution network planning. NLP is generally used where the objective function and the problem constraints are nonlinear such as voltage profile security, power system operation, planning and quality, dynamic security, capacitor position placement, reactive power control, and optimization of controller parameters.

Many authors introduce a combination of PSO and different evolutionary computation (EC) techniques to increase the population diversity by stopping the particles to move in a way too close to each other and be collided and let the self-adapting for optimization parameters such as the acceleration constants and inertia weight. In [55] a hybrid PSO technique with linear programming (LP) where LP is used to

obtain time multiplies setting (TMS), so the search space becomes smaller for PSO technique to find the suitable Ipickup.

In [7], In addition to taking into consideration near-end faults, it also deals with far-end faults and different topologies for the power system which may happen due to change in system configuration. So, the coordination problem becomes more complicated with many constraints. For this reason, the hybrid particle swarm optimization gravitational search algorithm (PSOGSA) is applied to the DOCR coordination problem to define the optimal solution for the relay coordination problem.

#### IV. PROTECTION COORDINATION METHODS FOR MITIGATION DGs PENETRATION

Many approaches are introduced to solve coordination problems raised due to the penetration of DGs. These approaches could be classified into two sections, one section is regarding minimal changes in the conventional protection system that in turn will reduce the costs of mitigation DGs impact. The other approach is regarding some modification in the conventional protection system of the distribution system by applying new components related to the protection system.

##### A. Strategies for Conventional Protection Schemes with Minimal Changes

In this section, mitigation of the negative impact of DG is introduced by applying strategies where the low change in conventional protection schemes is applied. These strategies are governed by minimizing the implementation costs. A comparison between the advantages and disadvantages of these approaches are shown in Table 1.

##### 1) Disconnect DGs at fault condition

In this solution, the interconnected DGs in the distribution system should be disconnected during the fault time immediately to avoid the protected zones being affected when the fault happens and prevent islanding so no change in protection coordination is required after adding DGs in the distribution system. In [15] a proposed study related to fuse coordination problem that disconnects all existing DGs during fault status.

Using this method leads to limit the DG capacity in the system and reduces the capability of DGs to act as a backup in the system, and DG disconnection could disturb the network which may affect the system reliability.

Meanwhile, for a distribution system that is equipped with an islanding capability, the optimal solution is the DG stays in service where the usage of DGs is increased, so some loads that in healthy portion could be supplied. If this is applicable, this improves the reliability of the network. For this strategy, the DG should remain connected to sustain the recovery of voltage by using fault ride through capability (FRT) [16].

## 2) *DG remains connected when Faults happen*

In this scenario, DGs that have FRT capability is used to avoid the DGs being disconnected from the islanded part of the network part because of the faults. Using FRT helps in protecting supplying the customers and to help the network at contingencies period [16]. The idea of FRT is to delay the time of trip the circuit to prevent disconnection of DGs.

## 3) *Limiting DG Output Current*

In [17], a method is proposed to reduce the negative impact of DGs by inverter-based DGs in the distribution system. This could be done by limiting the output current of the DG regarding terminal voltage of the DG. this method effectively utilizes the DG sizes and does not apply any modification in the existing network.

## 4) *Optimal DG size and location*

This technique aims to obtain the optimal size and location for the DGs that penetrate the network where the protection system could be fulfilled and not affected with the penetration of DGs by applying optimal power flow to limit the capacity of DG and enable the decision maker to decide the investment in the future [18]. In [19], a combination between two different optimization methods is introduced to define the optimal size and location of DGs in the distribution system using cuckoo search (CS) technique and grasshopper optimization algorithm (GOA) which is tested in IEEE 33-bus system and IEEE 69-bus system.

## 5) *Resetting of some or all protective relays*

Resetting of protective relays is another strategy stated in [20]. Though it is simple and cheap, it is a time-consuming process for operation staff in large systems [21]. Also, any fault could happen during this process that may be treated in a wrong way by the protective relays that leads to maloperation for the protection system.

## *B. Strategies with Modified Conventional Protection Schemes*

This section is based on strategies to mitigate DG penetration negative impact through modification in the conventional protection schemes for protection devices after penetration DGs in the distribution system using mathematical and computer-based techniques. A comparison between the advantages and disadvantages of these approaches is shown in Table 2.

### 1) *Protection relays strategies*

This solution is describing strategies of using relays as main protection devices to mitigate the negative impact of DGs penetration as follows:

#### 1.1) *Directional overcurrent relay*

Penetration DGs transfer the nature of distribution system current flow to be bidirectional which increase the importance of directional feature to be existing in the overcurrent relays [21].

#### 1.2) *Distance relay*

Distance relay is considered as a main protection relay for transmission network, beside in used also in distribution system. Distance relay has a direction element that make it suitable to used in meshed systems. In [70] introduces using distance relays to mitigate the reverse power flow effect due to integration of DGs.

#### 1.3) *Differential relay*

In [71], bidirectional current flow and increase in fault current level as results of DGs penetration is mitigated using proposed strategy using differential relay.

## 2) *Modifying the network equipment*

This solution is based on reconfiguring the network and resizing the network breakers to be suitable for the new current profile after adding DGs in the distribution system which is a costly and complicated solution [22].

## 3) *Obtaining new relay coordination*

This section is based on modifying the coordination between the protection devices directly if the parameters of the network changed because of adding DGs and this could be achieved through different techniques as follows:

### 3.1) *Adaptive protection scheme*

This scheme is based on automatic change for the protection parameters regarding any change in power system parts to keep the protection system acting properly with the changes.

In [23], the proposed technique provides relays with the ability to interact with any change that could happen through the network where communication between these devices and the measurements of current and voltage that make the setting of the device could be changed dynamically with using a processing computer.

The adaptive protection scheme relies on the used communications that could face cybersecurity attacks and reliability problems. Also, this technique faces high costs and technical complexity.

Adaptive protection usage enables microgrid topologies protection against all fault scenarios by a pre-calculated setting for the relay to cover different topologies and save them in its memory. When the topology changes, the relay updates its setting with a new one from the memory. A new type of relay can save at least 6 settings to cover different scenarios for the fault which in turn improves the relay sensitivity [24].

In [25], the fuse-recloser coordination problem is studied, and disconnecting all DGs in the distribution system during



fault time is proposed as a solution. This solution is not practical as it disconnects all DGs, and it would be not efficient to be applied in networks that have large penetration of DGs. An adaptive protection scheme is suggested to fix the issue related to disconnecting DGs as it divides the network into many zones taking into consideration the DGs location and size as each DG is in one zone. After performing the zoning process and determining each zone boundaries, switches are installed between every two zones that can receive a remote signal, operate quickly, and ability to synchronize during reconnect as shown in Fig.6. to achieve the adaptive scheme, a computer-based relay is suited in the substation that has high processing and storage with large capacity.

A new protection coordination scheme is proposed in [28] to increase the generation units that could be installed in the distribution system and to avoid high fault clearing periods. the time-dependent characteristics of current, and the overcurrent principle are used in this scheme where introduces

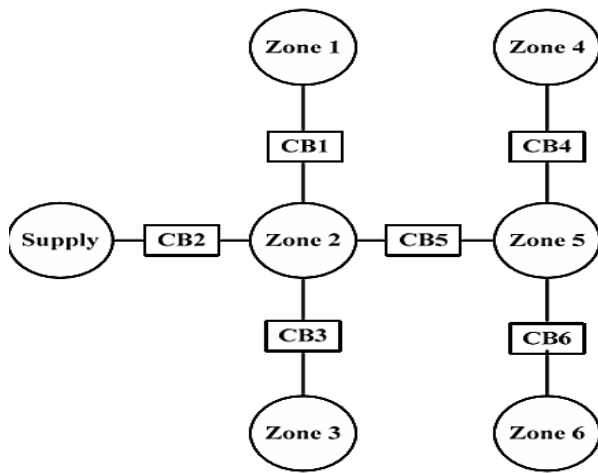

Fig. 6 several zones in distribution system with switches

the ability to run large radial systems or meshed structures, so reduces the outage times and fault clearing times. Also, in [29], it is presented an adaptive protection scheme that modifies the pickup current values regarding the analysis of fault current. However, it only focused on inverter-based DGs. In [30], A fast protection scheme is proposed based on setting groups in each overcurrent relay using Particle Swarm Optimization-Integer Linear Programming (PSO-ILP) algorithm. In this scheme, each relay changes its setting group individually regarding the change in network configuration to keep the coordination between relays fulfilled.

### 3.2) Multi-Agent protection scheme

The concept of a multi-agent protection scheme is a computer-based system that can perform autonomously to achieve its purpose. Autonomy phenomena is that the components of the system could work solely regarding their control. The environment that agents can function is typically

computational. The infrastructure contains communication protocols [31].

In [32] a multi-agent scheme is proposed where the network is divided into many segments. The processes of detecting of the fault current and isolating of the fault are established by the installation of the agents of the relays at the interconnection points between the segments in the network, as shown in Fig.7.

Communications are occurred between each agent and the near agents through networks by using a wavelet transform mechanism to define the fault current direction regarding a node in the distribution system. When a fault happens, the corresponding agents define the faulty zone by collecting feedback signals from every current transformer (CT) that is suited to the interconnected network branches.

The calculation for Wavelet transform coefficients (WTCs) is performed after fault current is measured in the branches. Depending on the sign of (WTC), the fault current can be classified as internal or external. Relay agents can determine the fault current direction and transmit the data to the close relay agents. Then, the relay agents can define the faulty segment to send the correct trip signals to the regarding CBs to clear the faulty segment.

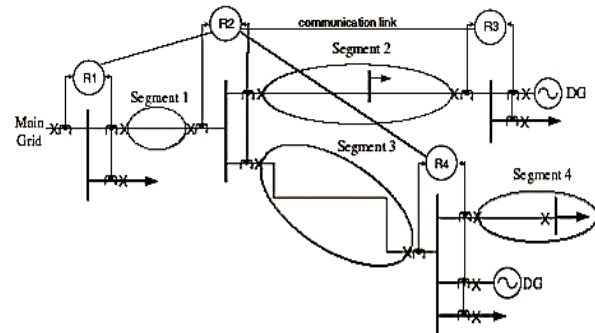

Fig. 7. Multi-agent-based structure network

### 3.3) Expert system for protection coordination

The concept of the expert system is an algorithm that functions in a way like human experts [33]. This strategy is applied to protection coordination in a radial network [34].

This strategy uses a knowledge base technique to improve the protection coordination of the protection devices to mitigate the negative impact of the penetration of DGs. This could happen by receiving input data through using a user interface to develop relays settings based on power flow and short-circuit analyses [34].

### 4) Limiting fault current levels

In this approach, mitigation of DGs impact is obtained through modification of fault current levels through using external devices such as energy storage devices and fault current limiters (FCL) to make the fault current to the value before adding DGs.

#### 4.1) Energy storages scheme

During the operation of islanded mode, the fault current value produced from the inverter-based DG is remarkably less than before islanded mode. Regarding this, the protection relays cannot initiate the overcurrent protection relays that are suited in the system.

Because of this issue, the network needs to install energy storage devices that could increase the fault current level such as batteries, flywheels, and capacitors to allow the protection devices to work properly [16]. These devices are expensive which is considered as the main issue in using them in the distribution system.

#### 4.2) Fault current limiter

FCL is used as a solution to limit the value of fault current, as it can reduce the fault current levels to the levels before adding DGs in the network [35, 20, 36]. In normal operation, its impedance is negligible and does not cause any voltage drop and connected in series and fault condition, its impedance increase to reduce the fault current [37].

In [38], Two scenarios are suggested based on the existing protection system to regain the protection coordination between overcurrent relays in the network that are equipped with DGs and without the need to disconnect the DGs from the system during faults. The first approach applied for an adaptive protection system, this approach decides the optimal number of relays, their settings, and locations. The second approach is applied for a nonadaptive protection system where uses the FCL.

In [39], a proposed scenario is used to define the optimal allocation for FCLs in distribution system considering different configuration which is tested in IEEE 30-bus system.

### V. APPLICATION OF FCL AS SOLUTION FOR DG'S PENETRATION

FCL is equipment that is installed in series in the distribution system to reduce the fault current levels. FCL is designed to have approximately zero impedance value at normal operation without faults and during the fault, a large impedance is introduced in the line to limit the fault current.

Applying FCL in the network as a solution for the negative impact of penetration of DGs has many challenges as it is considered the extra cost and short life in comparison to the traditional circuit breakers, and maintenance cost. To overcome these issues and any negative impact from using FCL in the network in the operation of the protection devices, a proper allocation for the FCL should be executed for efficient and practical usage of FCL [56].

Using FCL in a power network not only for limiting fault current, but also has many benefits as reducing inrush current of transformers, voltage sag, loss of power, damping of low-frequency oscillation, and improving reliability, quality of the network.

The impedance of the FCL that installed is represents the size of the FCL which is a function of cost as the size increase, the cost increase [21]. Regarding the fact that FCL can reduce the fault current levels to levels before adding DGs, So, the need to replace power system equipment or reset the protection system disappears [57]. Also, FCL enhances the reliability of the power system by limiting the failure times of the system components [58].

Although the solid-state type of FCL has many advantages regarding other types, the losses of switching are considered as the major issue for it [59].

To solve these problems and to design an economic FCL, the hybrid fault current limiting device is developed. The advantages of the hybrid FCL are it can direct a half-cycle current and then in the second half cycle, it can limit the fault current which obtains optimal limiting for the fault current.

Fig. 8 shows the hybrid SFCL schematic, the hybrid SFCL contains the following parts: the high temperature superconducting (HTS) element that senses the fault current and is used for commutating the fault current, but not used for reducing the current. So, the length of the superconductor can be reduced and hence reduce the total cost.

The fast-switching element that contains a driving coil, a short contactor, and a vacuum interrupter. The driving coil is suited on a path that is connected parallel with the superconducting element. After the commutation of the fault current, the driving coil produces repulsion force. Because of this force, the contacts of the vacuum interrupter are separated at high speed. The current limiting element could be resistive or inductive [60].

In [61], Selecting the FCL size and type is performed using the optimization technique. But the coordination problem between relays does not apply. Also, in [62] the authors are proposed a scenario to find the optimal location and size of FCLs in a meshed network by applying mixed integer nonlinear programming technique.

In [62], the application of FCLs is proposed to restore the protection coordination after penetration of DGs where the FCLs location and size are defined through using the trial-and-error method. But the FCLs that result from this approach have large sizes which in turn increase the costs.

In [21], the authors applied optimal planning with different types of FCLs to solve the relay coordination problem after adding DGs. Although the obtained small FCLs sizes, the cost of FCLs remains high.

In [20], an approach is introduced which combines the application of FCLs with resetting relays to solve the relay coordination problem. This technique defines FCLs location through try ad error. Then, apply resetting to one relay to reduce the total size of FCLs.

But the resulted FCLs sizes and locations are not an optimal solution.



TABLE 1  
COMPARISON OF STRATEGIES FOR CONVENTIONAL PROTECTION SCHEMES WITH MINIMAL CHANGES

Strategies	Advantages	disadvantages	Protection devices	Costs
<i>1-Protection relay strategies</i>				
<i>a- Overcurrent relay</i>	<ul style="list-style-type: none"> <li>• Sense the current flow from both directions.</li> <li>• High selectivity capability.</li> </ul>	<ul style="list-style-type: none"> <li>• High cost.</li> <li>• Difficulties in coordination for all possible scenarios.</li> </ul>	Overcurrent relay	Expensive
<i>b- Distance relay</i>	<ul style="list-style-type: none"> <li>• Setting of the relays remain constant for wide range of changes.</li> <li>• Faster in comparison of different relays.</li> </ul>	<ul style="list-style-type: none"> <li>• Required voltage transformer that adding costs.</li> <li>• Complicated setting procedures.</li> </ul>	Distance relay	Reasonable
<i>Differential relay</i>	<ul style="list-style-type: none"> <li>• Not affected by the negative effect of bidirectional flow</li> </ul>	<ul style="list-style-type: none"> <li>• Difficult to apply and need communication links.</li> </ul>	Digital relay	Expensive
<i>2- Disconnect DGs at fault condition</i>	<ul style="list-style-type: none"> <li>• Protect healthy zone at faults.</li> <li>• Prevent islanding condition.</li> <li>• Protect DG itself.</li> <li>• No need to change protection devices settings.</li> </ul>	<ul style="list-style-type: none"> <li>• Limiting the network DG capacity.</li> <li>• Reduce the capability of DG as an alternative source.</li> <li>• Reduce system reliability due to disconnection of DGs every time fault occurs.</li> </ul>	Overcurrent Relay	Reasonable
<i>3-DG remain connected</i>	<ul style="list-style-type: none"> <li>• Possibility of increasing FRT capability.</li> <li>• Support voltage recovery.</li> <li>• Increase reliability and security of the network.</li> </ul>	<ul style="list-style-type: none"> <li>•Applying FRT capability enhancement techniques is expensive.</li> <li>• FRT is depending on the robustness of the network.</li> <li>• Difficult to detect and isolate the fault.</li> <li>•Risk of islanding.</li> </ul>	Overcurrent Relay	Expensive
<i>4- Limiting DG Output Current</i>	<ul style="list-style-type: none"> <li>• Implementation easily</li> <li>• No limitation to the size of existing DGs.</li> <li>• No modification in network.</li> </ul>	Applicable only for inverter based DGs	Fuse-recloser combination	Reasonable.
<i>5- Optimal DG size and location</i>	<ul style="list-style-type: none"> <li>• No effect on protection system.</li> <li>• Efficient application of the new DGs added according to optimization methods.</li> <li>• Minimize loss of protection coordination.</li> </ul>	<ul style="list-style-type: none"> <li>•Limiting adding DGs regarding their rated capacity.</li> <li>• Difficulties in determining the DG size and placement because of the geographical constraint, and land area.</li> <li>• Decrease the chance to sell electricity when DG has extra generated power because of the limitation of DG capacity.</li> </ul>	Overcurrent Relay	Reasonable.

TABLE 2  
COMPARISON OF MODIFIED PROTECTION STRATEGIES FOR CONVENTIONAL NETWORK CONNECTED WITH DG

Strategies	Advantages	disadvantages	Communication link	Costs
<i>1- Obtaining new relay coordination</i>	<ul style="list-style-type: none"> <li>•Dynamic change features in relay coordination setting.</li> <li>•Improves the speed of operation through using communications.</li> <li>•Standardized the communication by using of universal protocol language.</li> </ul>	<ul style="list-style-type: none"> <li>•Higher cost of applying analysis data as it takes large Computational storage.</li> <li>•Usage of expensive digital relays and advances network infrastructure for communication.</li> <li>•Miscoordination between protective devices if any failure happens in communication.</li> </ul>	Need for communication infrastructure.	Expensive
<i>2- Limiting fault current levels</i>	<ul style="list-style-type: none"> <li>•Cost of using FCLs is lower than Upgrade sub-station.</li> <li>•Suitable solution for network multiple DGs penetration.</li> <li>•Using FCLs increases the recovery time where reduced disruption.</li> <li>•Reliability improvement through using FCLs.</li> <li>•Quick grid voltage recovery through usage of energy storage.</li> </ul>	<ul style="list-style-type: none"> <li>•Difficulties in determining the FCLs Impedance values for the rotating-based DG.</li> <li>•Use of expensive storage devices to withstand high levels of fault current.</li> <li>•Limited usage of energy storage for DGs inverter Based.</li> </ul>	No need.	Reasonable.

In [63], the authors suggested an approach to obtain FCLs allocation to limit the current surges by using two-stage scenarios. A combination of hierarchical fuzzy logic with a generic algorithm is applied to obtain the optimal locations of FCLs. After that, the PSO technique is introduced to obtain the optimal size of the FCL. The authors in [64] suggested an index for protection coordination. Then, using this index in finding the locations and sizes related to the FCLs. A proposed approach is developed to obtain the optimal FCL size by using biogeography optimization technique as stated in [65].

In [66,67], superconducting fault current limiter is applied to mitigate the effect of DGs penetration through reestablishing the protection coordination between fuses and reclosers by limiting the DGs share percentage in fault current to obtain the levels before adding DGs.

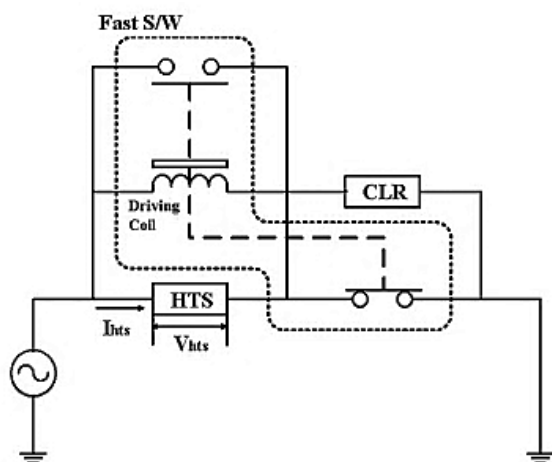

Fig. 8 Simple structure for Hybrid SFCL

In [68], application of FCL that connected in series to the DGs location as a solution to mitigate the DGs penetration negative impact. In [69], the author introduces the usage of directional fault current limiter between the microgrid and rest of the network as a solution to mitigate the negative impact results from integration of DGs in microgrid.

## VI. CONCLUSION

Protection system faces many challenges due to the large penetration of DGs, these challenges are addressed which mainly appear because of DGs fault current sharing that increase the fault current levels and their direction.

Different strategies for solving these challenges are discussed. Some strategies depend on minimum change in the protection system and others depend in noticeable change in the configuration of the protection system. A comparison between these strategies is performed regarding cost and complexity to apply is addressed. The comparison shows the benefits of using FCL as a optimal solution.

## AUTHORS CONTRIBUTION

**Adel Amer did the following:**

1. Drafting the article.
2. Research idea development.
3. Supervision.
4. Project administration.
5. Provide the required resources.
6. Data gathering and perform the comparison.
7. Edit and review the article.

**Eid A. Gouda did the following:**

1. Data gathering and analysis.
2. Drafting the article.
3. Permanent supervision.
4. Critical revision of the article.
5. Project administration.

**Akram Elmitwally did the following:**

1. Research idea development.
2. Permanent supervision.
3. Project administration.
4. Final approval of the version to be published.

## FUNDING STATEMENT:

No financial support was received

## DECLARATION OF CONFLICTING INTERESTS STATEMENT:

The author declared that there are no potential conflicts of interest with respect to the research authorship or publication of this article.

## REFERENCES

- [1] G. Walker, "Renewable energy and the public," *Land Use Policy*, vol. 12, no. 1, pp. 49–59, 1995.
- [2] G. Pepermans, J. Driesen, D. Haeseldonckx, R. Belmans, and W. D'haeseleer, "Distributed generation: Definition, benefits and issues," *Energy Policy*, vol. 33, no. 6, pp. 787–798, 2005.
- [3] S. Conti and S. Nicotra, "Procedures for fault location and isolation to solve protection selectivity problems in mv distribution networks with dispersed generation," *Electric Power Systems Research*, vol. 79, no. 1, pp. 57–64, 2009.
- [4] H. Kuang, S. Li, and Z. Wu, "Discussion on advantages and disadvantages of distributed generation connected to the grid," *2011 International Conference on Electrical and Control Engineering*, 2011.
- [5] H. Zayandehroodi, A. Mohamed, H. Shareef, M. Mohammadjafari, and M. Farhoodnea, "A novel PROTECTION coordination strategy using back tracking algorithm for distribution systems with high penetration of DG," *2012 IEEE International Power Engineering and Optimization Conference*, 2012.
- [6] P. Prakash and D. K. Khatod, "Optimal sizing and siting techniques for distributed generation in distribution systems: A review," *Renewable and Sustainable Energy Reviews*, vol. 57, pp. 111–130, 2016.
- [7] A. Elmitwally, M. S. Kandil, E. Gouda, and A. Amer, "Mitigation of DGs impact on variable-topology meshed network protection system by optimal fault current limiters considering overcurrent relay coordination," *Electric Power Systems Research*, vol. 186, p. 106417, 2020.
- [8] M. Ezzeddine and R. Kaczmarek, "A novel method for optimal coordination of directional overcurrent relays considering their available discrete settings and several operation characteristics," *Electric Power Systems Research*, vol. 81, no. 7, pp. 1475–1481, 2011.

- [9] V. R. Pandi, H. H. Zeineldin, and W. Xiao, "Determining optimal location and size of distributed generation resources considering harmonic and protection coordination limits," *IEEE Transactions on Power Systems*, vol. 28, no. 2, pp. 1245–1254, 2013.
- [10] J. A. Momoh, Y. Xia, and G. D. Boswell, "An approach to Determine distributed Generation (DG) benefits in power networks," *2008 40th North American Power Symposium*, 2008.
- [11] P. P. Barker and R. W. De Mello, "Determining the impact of distributed generation on power SYSTEMS. I. radial distribution systems," *2000 Power Engineering Society Summer Meeting (Cat. No.00CH37134)*.
- [12] H. Wan, K. P. Wong, and C. Y. Chung, "Multi-agent application in protection coordination of power system with distributed generations," *2008 IEEE Power and Energy Society General Meeting - Conversion and Delivery of Electrical Energy in the 21st Century*, 2008.
- [13] H. Cheung, A. Hamlyn, C. Yang, and R. Cheung, "Network-based adaptive protection strategy for feeders with distributed generations," *2007 IEEE Canada Electrical Power Conference*, 2007.
- [14] Y. Baghzouz, "Voltage regulation and overcurrent protection issues in distribution feeders with distributed generation - a case study," *Proceedings of the 38th Annual Hawaii International Conference on System Sciences*.
- [15] S. K. De and P. Raja, "A study on relay coordination in a distribution system with distributed generation and hybrid sfcl," *2013 Africon*, 2013.
- [16] J. Hossain and H. R. Pota, "Control for Fault Ride-Through Capability Augmentation," *Power Systems*, pp. 153–218, 2014.
- [17] H. Yazdanpanahi, Y. W. Li, and W. Xu, "A new control strategy to mitigate the impact Of Inverter-based Dgs on protection system," *IEEE Transactions on Smart Grid*, vol. 3, no. 3, pp. 1427–1436, 2012.
- [18] S. Sharma, N. S. Velgipudi, and K. Pandey, "Performance analysis of IEEE 9 bus system USING TCSC," *2017 Recent Developments in Control, Automation & Power Engineering (RDCAPE)*, 2017.
- [19] M. C. V. Suresh and J. B. Edward, "A hybrid algorithm based optimal placement of DG units for loss reduction in the distribution system," *Applied Soft Computing*, vol. 91, p. 106191, 2020.
- [20] D. K. Ibrahim, E. E. Abo El Zahab, and S. A. Mostafa, "New coordination approach to minimize the number of re-adjusted relays when adding dgs in interconnected power systems with a minimum value of fault current limiter," *International Journal of Electrical Power & Energy Systems*, vol. 85, pp. 32–41, 2017.
- [21] A. Elmitwally, E. Gouda, and S. Eladawy, "Optimal allocation of fault current limiters for sustaining overcurrent relays coordination in a power system with distributed generation," *Alexandria Engineering Journal*, vol. 54, no. 4, pp. 1077–1089, 2015.
- [22] H. Yazdanpanahi, Y. W. Li, and W. Xu, "A new control strategy to mitigate the impact Of Inverter-based Dgs on protection system," *IEEE Transactions on Smart Grid*, vol. 3, no. 3, pp. 1427–1436, 2012.
- [23] H. Javadi, S. M. Ali Mousavi, and M. Khederzadeh, "A novel approach to INCREASE Fcl application in preservation of over-current RELAYS coordination in presence of asynchronous DGs," *International Journal of Electrical Power & Energy Systems*, vol. 44, no. 1, pp. 810–815, 2013.
- [24] M. Norshahrani, H. Mokhlis, A. Abu Bakar, J. Jamian, and S. Sukumar, "Progress on protection strategies to mitigate the impact of renewable distributed generation on distribution systems," *Energies*, vol. 10, no. 11, p. 1864, 2017.
- [25] S. M. Brahma and A. A. Girgis, "Microprocessor-based reclosing to coordinate fuse and recloser in a system with high penetration of distributed generation," *2002 IEEE Power Engineering Society Winter Meeting. Conference Proceedings (Cat. No.02CH37309)*.
- [26] N. Rezaei and M.-R. Haghifam, "Protection scheme for a distribution system with distributed generation using neural networks," *International Journal of Electrical Power & Energy Systems*, vol. 30, no. 4, pp. 235–241, 2008.
- [27] S. A. Javadian, M.-R. Haghifam, and N. Rezaei, "A fault location and protection scheme for distribution systems in presence of dg using MLP neural networks," *2009 IEEE Power & Energy Society General Meeting*, 2009.
- [28] J. Jager, "New protection co-ordination methods in the presence of distributed generation," *Eighth IEE International Conference on Developments in Power System Protection*, 2004.
- [29] M. Baran and I. El-Markabi, "Adaptive over current protection for distribution feeders with distributed generators," *IEEE PES Power Systems Conference and Exposition*, 2004.
- [30] "SC currents minimization in distributed generation embedded distribution networks with optimal application of fcls," *CSEE Journal of Power and Energy Systems*, 2020.
- [31] N. Perera and A. D. Rajapakse, "Agent-based protection scheme for distribution networks with distributed generators," *2006 IEEE Power Engineering Society General Meeting*, 2006.
- [32] H. Wan, K. K. Li, and K. P. Wong, "An adaptive Multiagent approach to Protection relay coordination with distributed generators in industrial power distribution system," *IEEE Transactions on Industry Applications*, vol. 46, no. 5, pp. 2118–2124, 2010.
- [33] J. C. Tan, P. A. Crossley, D. Kirschen, J. Goody, and J. A. Downes, "An expert system for the back-up protection of a transmission network," *IEEE Transactions on Power Delivery*, vol. 15, no. 2, pp. 508–514, 2000.
- [34] K. Tuitemwong and S. Premru deepreechacham, "Expert system for protection coordination of distribution system with distributed generators," *International Journal of Electrical Power & Energy Systems*, vol. 33, no. 3, pp. 466–471, 2011.
- [35] P. Yu, B. Venkatesh, A. Yazdani, and B. N. Singh, "Optimal location and sizing of fault CURRENT limiters in mesh networks using ITERATIVE mixed Integer nonlinear programming," *IEEE Transactions on Power Systems*, vol. 31, no. 6, pp. 4776–4783, 2016.
- [36] M. Ezzeddine and R. Kaczmarek, "A novel method for optimal coordination of directional overcurrent relays considering their available discrete settings and several operation characteristics," *Electric Power Systems Research*, vol. 81, no. 7, pp. 1475–1481, 2011.
- [37] R. M. Chabanloo, H. A. Abyaneh, A. Agheli, and H. Rastegar, "Overcurrent relays coordination Considering TRANSIENT behaviour of fault current limiter and distributed generation in distribution power network," *IET Generation, Transmission & Distribution*, vol. 5, no. 9, p. 903, 2011.
- [38] W. El-khattam and T. S. Sidhu, "Resolving the impact of distributed renewable generation on directional overcurrent relay coordination: A case study," *IET Renewable Power Generation*, vol. 3, no. 4, p. 415, 2009.
- [39] M. Khederzadeh, "Application of TCSC to restore DIRECTIONAL OVERCURRENT relay coordination in systems with distributed generation," *IET Conference Publications*, 2009.
- [40] "Distribution system protection and control," *Electric Power Distribution, Automation, Protection, and Control*, pp. 85–132, 2017.
- [41] N. Bayati, H. R. Baghaee, A. Hajizadeh, and M. Soltani, "A fuse saving scheme for dc microgrids with high penetration of renewable energy resources," *IEEE Access*, vol. 8, pp. 137407–137417, 2020.
- [42] K. Wheeler, M. Elsamahy, and S. Faried, "Use of superconducting fault current limiters for mitigation of distributed generation influences in radial distribution network fuse–recloser protection systems," *IET Generation, Transmission & Distribution*, vol. 11, no. 7, pp. 1605–1612, 2017.
- [43] S. Jamali and H. Borhani-Bahabadi, "Recloser Time–current–voltage characteristic For FUSE saving in distribution networks with DG," *IET Generation, Transmission & Distribution*, vol. 11, no. 1, pp. 272–279, 2017.
- [44] R. Perveen, N. Kishor, and S. R. Mohanty, "Fault detection and optimal coordination of overcurrent relay in offshore wind farm connected to onshore grid with VSC-HVDC," *International Transactions on Electrical Energy Systems*, vol. 26, no. 4, pp. 841–863, 2015.
- [45] A. Shrivastava, J. M. Tripathi, R. Krishan, and S. K. Parida, "Optimal coordination Of Overcurrent Relays using Gravitational search algorithm with Dg penetration," *IEEE Transactions on Industry Applications*, pp. 1–1, 2017.
- [46] A. Shrivastava, J. M. Tripathi, S. R. Mohanty, and B. Panda, "Optimal over-current relay coordination with distributed generation using hybrid particle swarm optimization–gravitational search algorithm," *Electric Power Components and Systems*, vol. 44, no. 5, pp. 506–517, 2016.
- [47] A. J. Urdaneta, R. Nadira, and L. G. Perez Jimenez, "Optimal coordination of directional overcurrent relays in interconnected power systems," *IEEE Transactions on Power Delivery*, vol. 3, no. 3, pp. 903–911, 1988.
- [48] J. Senthilnath, S. N. Omkar, and V. Mani, "Clustering using firefly algorithm: Performance study," *Swarm and Evolutionary Computation*, vol. 1, no. 3, pp. 164–171, 2011.
- [49] R. Benabid, M. Zellagui, M. Boudour, and A. Chaghi, "Considering the series compensation in optimal coordination of directional overcurrent protections Using PSO technique," *2013 IEEE Jordan Conference on*

- Applied Electrical Engineering and Computing Technologies (AEECT)*, 2013.
- [50] M.-T. Yang and A. Liu, "Applying hybrid Pso to Optimize Directional Overcurrent relay coordination in Variable network topologies," *Journal of Applied Mathematics*, vol. 2013, pp. 1–9, 2013.
- [51] D. Uthitsunthorn, P. Pao-La-Or, and T. Kulworawanichpong, "Optimal overcurrent relay coordination using artificial bees colony algorithm," *The 8th Electrical Engineering/ Electronics, Computer, Telecommunications and Information Technology (ECTI) Association of Thailand - Conference 2011*, 2011.
- [52] V. Rashtchi, J. Gholinezhad, and P. Farhang, "Optimal coordination of OVERCURRENT Relays using honey Bee algorithm," *International Congress on Ultra-Modern Telecommunications and Control Systems*, 2010.
- [53] R. Eberhart and J. Kennedy, "A new optimizer using particle swarm theory," MHS'95. Proceedings of the Sixth International Symposium on Micro Machine and Human Science.
- [54] Y. del Valle, G. K. Venayagamoorthy, S. Mohagheghi, J.-C. Hernandez, and R. G. Harley, "Particle swarm Optimization: Basic Concepts, variants and applications in power systems," *IEEE Transactions on Evolutionary Computation*, vol. 12, no. 2, pp. 171–195, 2008.
- [55] J. Sadeh, V. Amintojjar, and M. Bashir, "Coordination of overcurrent and distance relays using hybrid particle swarm optimization," *2011 International Conference on Advanced Power System Automation and Protection*, 2011.
- [56] S. Ouali and A. Cherkaoui, "Integration of fault current limiters in electric Power Systems: A review," *IEEE Systems Journal*, pp. 1–10, 2020.
- [57] S. Hemmati and J. Sadeh, "Applying superconductive fault current limiter to minimize the impacts of distributed generation on the distribution protection systems," *2012 11th International Conference on Environment and Electrical Engineering*, 2012.
- [58] Lin Ye, M. Majoros, T. Coombs, and A. M. Campbell, "System studies of the superconducting fault current limiter in electrical distribution grids," *IEEE Transactions on Applied Superconductivity*, vol. 17, no. 2, pp. 2339–2342, 2007.
- [59] A. Elmitwally, "Proposed hybrid superconducting fault current limiter for distribution systems," *International Journal of Electrical Power & Energy Systems*, vol. 31, no. 10, pp. 619–625, 2009.
- [60] Gyeong-Ho Lee, Kwon-Bae Park, Jungwook Sim, Young-Geun Kim, Il-Sung Oh, Ok-Bae Hyun, and Bang-Wook Lee, "Hybrid superconducting fault current limiter of the first half CYCLE Non-Limiting Type," *IEEE Transactions on Applied Superconductivity*, vol. 19, no. 3, pp. 1888–1891, 2009.
- [61] H. H. Zeineldin and W. Xiao, "Optimal fault current limiter sizing for distribution systems with DG," *2011 IEEE Power and Energy Society General Meeting*, 2011.
- [62] W. El-Khattam and T. S. Sidhu, "Restoration of directional overcurrent relay coordination in distributed generation systems utilizing fault current limiter," *IEEE Transactions on Power Delivery*, vol. 23, no. 2, pp. 576–585, 2008.
- [63] H.-T. Yang, W.-J. Tang, and P. R. Lubicki, "Placement of fault current limiters in a power system through a Two-stage optimization approach," *IEEE Transactions on Power Systems*, vol. 33, no. 1, pp. 131–140, 2018.
- [64] H. Zeineldin, E. El-Saadany, and L. Huchel, "Protection coordination Index ENHANCEMENT considering multiple Dg locations using FCL," *2017 IEEE Power & Energy Society General Meeting*, 2017.
- [65] S. Ghaemi and M. Abapour, "Effect of fault current Limiter (FCL) on reliability and PROTECTION coordination of distribution system," *2016 24th Iranian Conference on Electrical Engineering (ICEE)*, 2016.
- [66] A. Heidary, H. Radmanesh, K. Rouzbehi, A. Mehrizi-Sani, and G. B. Gharehpetian, "Inductive fault current limiters: A review," *Electric Power Systems Research*, vol. 187, p. 106499, 2020.
- [67] A. Y. Hatata, A. S. Ebeid, and M. M. El-Saadawi, "Application of resistive super conductor fault current limiter for protection of grid-connected dgs," *Alexandria Engineering Journal*, vol. 57, no. 4, pp. 4229–4241, 2018.
- [68] R. Mohammadi Chabanloo, M. Ghotbi Maleki, S. M. Mousavi Agah, and E. Mokhtarpour Habashi, "Comprehensive coordination of radial distribution network protection in the presence of synchronous distributed generation using fault current limiter," *International Journal of Electrical Power & Energy Systems*, vol. 99, pp. 214–224, 2018.
- [69] T. Amraee, "Coordination of directional overcurrent relays using seeker algorithm," *IEEE Transactions on Power Delivery*, vol. 27, no. 3, pp. 1415–1422, 2012.
- [70] H. Mortazavi, H. Mehrjerdi, M. Saad, S. Lefebvre, D. Asber, and L. Lenoir, "Application of distance relay for distribution system monitoring," *2015 IEEE Power & Energy Society General Meeting*, 2015.
- [71] T. S. Ustun, C. Ozansoy, and A. Zayegh, "Differential protection of microgrids with Central Protection Unit Support," *IEEE 2013 Tencon - spring*, 2013.

#### Title Arabic:

نظرة عامة على نظام تنسيق الحماية في نظام التوزيع مع وجود التوليد الموزع.

#### Arabic Abstract:

يقدم هذا البحث نظرة عامة على فوائد التوليد الموزع في زيادة درجة الاعتمادية لنظام التوزيع ، والمشاكل الناتجة على منظومة الوقاية بسبب تداخل التوليد الموزع. و ايضا مراجعة السيناريوهات المختلفة للتناسق بين اجهزة الوقاية. علاوة على ذلك ، مراجعة طرق تنسيق الحماية بسبب دخول التوليد الموزع وتقديم مقارنة بين هذه الطرق المختلفة والتي تنقسم لانواع ذات التغيير البسيط على نظام الوقاية والانواع التي تعتمد على بعض التغيرات الكبيرة على نظام الوقاية وذلك للحصول على نظام وقاية امن وموثوق به وذلك كما كان قبل وضع التوليد الموزع في الشبكة وتوضيح عيوب و مميزات الطريقتين. وايضا مراجعة على استخدام جهاز محدد تيار الخطا كحل عملي لتقليل تاثير ظهور التوليد الموزع في الشبكة.