



## Improvement of Pipeline Settlement Using Micro Piles

Received 25 November 2021; Revised 14 January 2022; Accepted 16 January 2022

Nasser A. A. Radwan <sup>1</sup>

### Keywords

Loose Sand, Pipelines,  
Settlement, Improvement,  
Numerical Analysis, Praxis  
3D, Cross Piles, Confined  
Piles.

### Abstract

Loose sand soil is one of the problematic soils and according to that, buried pipelines interact with the loose sandy soil. Also, pipelines are subjected to additional stresses transmitted by the settlement of the loose sand soil which increases stresses and displacements in the pipes and eventually leads to breakage. Therefore, using micro-piles to improve soil below the pipeline is important. Praxis 3D numerical analysis software was used to investigate numerically the improvement of soil behaviour below pipeline Micro-piles installed as a cross piles configuration below pipeline and as a confining setup. Parameters studied are piles spacing, piles diameter, length, and effect of soil wetting. The pipeline was subjected to surface loads from a fully loaded truck. It was found that using micro-piles decreases slightly the settlement of pipelines resting on loose sands

## 1. Introduction

For more than a century, industrial activity in the world has been based on network pipelines. The pipeline network continues to expand in length and complexity, many problems will be encountered because pipelines must pass through areas with very different topographical and hydrogeological [1]. One of the mentioned conditions is the case of our study where, after doing a plate load test in the studied area in Sadat industrial city, a large settlement was noted if the soil flooded with water and these results are shown by field tests too. This means that if there is a structure on this soil, it will cause damage to the structure, so the conclusion from this is that if pipelines are built without soil improvement, the pipelines will be damaged. Therefore, soil improvement using the micro-piles technique is an important method to enhance the behaviour of the loose sandy soil. There are many technics like Vibro-flotation, soil cement, stone columns. Micro-piles were selected to avoid the additional stresses from the settlement of the loose sand soil which increases loads and displacements in the pipes and eventually leads to breakage [2].

Micro-Piles were used in Italy in the early 1950s as an innovative technique for the underpinning of historic buildings and monuments. In the present day, micro-piles are used

<sup>1</sup>Assoc. Professor, Housing and Building National Research Center (HBRC), 87 Tahrir St. EL-Dokki, Giza, Egypt, [nasserkhaled@yahoo.com](mailto:nasserkhaled@yahoo.com).

in several applications. Micro-piles system was selected in current research due to ease of the installation with minimal vibration or a disturbance which prevents damaging the surrounding infrastructure like roads which leads to problems like delaying production and transportation of supplies to nearby factories in the studied area. Micro-piles are constructed by drilling the pile shaft to the required depth then placing the steel reinforcement then initial grouting by tremie, and finally placing additional grout under pressure where applicable.

Some previous research on soil improvement using micro-piles technique includes:

**M. Mollaali et. al. [3]** investigated the effect of soil improvement using micro-piles on soil bearing capacity and subgrade modulus of mat foundation rested on weak soil layer. Two micro-pile grids spacing of  $1.5 \times 1.5 \text{m}^2$  and  $1.75 \times 1.75 \text{m}^2$  were used in the study. Finite element analysis software Praxis 2D was used in their research. It was concluded that the micro-pile technique is capable to enhance the design parameters of the foundation located on very weak soil layers. However, it is not effective in the case of foundations resting on medium or dense soils. **Reza Z. Moayed et. al. [4]** used micro-piles to improve the characteristics of loose sand soil deposits. A field study was conducted to investigate micro-piles effects on the behaviour of loose silty sand subjected to additional surface loading. Standard Penetration Test (SPT) and six plate-loading tests (300 mm diameter, 35 mm thick) were conducted on the loose silty sand stratum before and after micro-piles installation. It was found that micro-piles improve considerably the bearing capacity of soil and decrease the settlement. Also, the subgrade modulus of soil was improved too after micro-piles installation. Finally, it was concluded that micro-piles improve the liquefaction resistance of the sand.

The effect of using micro-piles on the bearing capacity of the foundation was studied by [5]. A numerical investigation using Praxis 2D was performed. The purpose of his research was to find the optimum configuration of micro-piles to obtain the maximum bearing capacity of foundations. It was concluded that the slope of micro-piles had a great effect on bearing capacity values. Other factors studied are diameters of micro-piles, length, and spacing between micro-piles. He found that the optimum spacing between piles is less than 20 cm and for the spacing more than 20 cm the spacing has almost no effect. An investigation using the finite element method of the effect of using micro-piles to improve the bearing capacity of the foundation was carried out by [6]. Praxis 2D computer program was used in the analysis. 4 m long and 100 mm diameters piles were used in the study. The spacing between piles was selected to be 200 mm. The micro-piles were inserted around the footings at an inclination of  $70^\circ$  with the horizontal. The finite element study confirms observed results obtained from the field.

A parametric study of buried pipes using Praxis 2D was performed by [7]. The studied parameters are influences of location and embedment ratio of pipes, properties of soil, and surcharge on the behaviour of buried pipes. Concrete and polyethylene (PE) pipes were studied. It was concluded that the location, embedment ratio of pipes, surcharge loads, and properties of sand are the main parameters that affect the behaviour of the buried pipe. Also, it was noted that pipe rigidity is an important factor. **Alireza M. Goltabar et. Al. [8]** carried out an experimental study to investigate the influence of traffic load on the behaviour of buried pipelines. The effect of the truck load was studied experimentally and using a numerical method by Praxis 3D finite element method software. A comparison between experimental method and numerical methods results was carried out. It was found that the numerical method results confirm the results obtained by the experimental method.

Other methods of soil improvement below pipeline like work done by [9], used Geogrid to reinforce soil below pipelines. A numerical investigation was carried out using Praxis 3D software to predict the behaviour of buried pipelines. The influence of using Geonet as a soil reinforcement under buried pipelines was studied by [10]. Results indicate that the geonet provides a proper reinforcement to the soil system which reduces the stress acting on the pipeline. More than a 25% reduction in strain on pipe was obtained. Also, a good agreement in measured strain values on the pipe was observed between the experimental and numerical studies. The aim of the current research is to predict the influence of a fully loaded truck on the behaviour of a buried pipeline resting on loose sand using a finite element software Praxis 3D and to investigate the effectiveness of using micro-piles on settlement reduction of pipelines. A parametric study was carried out to find the optimum micro-piles configuration, optimum spacing between piles. Also, the effect of ground water presence was studied, and the effect of piles diameters was. Finally, the effect of pile length was studied.

## 2. Numerical Study

A finite element method computer program (PLAXIS 3D Ver. 2020) [11] was used in the numerical study to investigate the effect of micro-piles installation on the settlement of buried pipelines on loose sand soil. Full modelling of soil, micro-piles, and loading are performed using the commercial FEM package PLAXIS 3D Version 2020.

## 3. Numerical Model Setup

Figures.1,2 show the numerical model setup. The overall dimensions of the model boundaries were taken as follows: length equals 6 times the pavement width, width equals 6 times the pavement width, and height equals 6 times the pavement width. These dimensions were considered adequate to eliminate the boundary effects. The outer boundary of the mesh is fixed against displacements. The soil was subjected to the loads from a single typical fully loaded a heavy concrete truck with a dual wheel load. The typical truck used in the analysis is shown in Fig. 3 where a typical fully loaded concrete truck exerts a total of 66,000 pounds (293 kN) on the pavement, 28,000 pounds (124.5 kN) on each of its rear axles. For simplification of the problem truck wheels loads were distributed over a circular area of a radius of 30 cm. The loads are transferred to the pavement surface consisting of asphalt concrete of thickness equal to 5 cm. The soil was modelled using the well-known Mohr-coulomb model which involves five input parameters, i.e., Elastic modulus (E) and Poisson's ratio ( $\nu_s$ ) for soil elasticity, friction angle ( $\phi$ ), cohesion (c) and dilatancy angle ( $\psi$ ). The Mohr-Coulomb model was validated to be used to simulate micro-piles soil interaction problems by [12].

The asphalt concrete pavement was simulated as a soil element using a linear elastic model. Micro-piles were modelled as embedded beam elements. PVC pipeline was modelled using a poly-curve tool and a plate element. The pipeline depth was 1 m below the ground surface. The parameters of materials used in the numerical model are shown in Table 1. As shown in Fig. 1, in the case of confining piles configuration, the spacing between piles varies between 25cm up to 100cm. To study the effect of pile diameter and length, the piles were tested at lengths from 2 up to 4m length. The diameters studied are 10cm, 15 and 20cm. The micro-

piles were constructed as a cross configuration as shown in Fig.2 where, the inclination of piles equals  $71^\circ$  with horizontal, spacing between piles varies from 25cm up to 100cm.

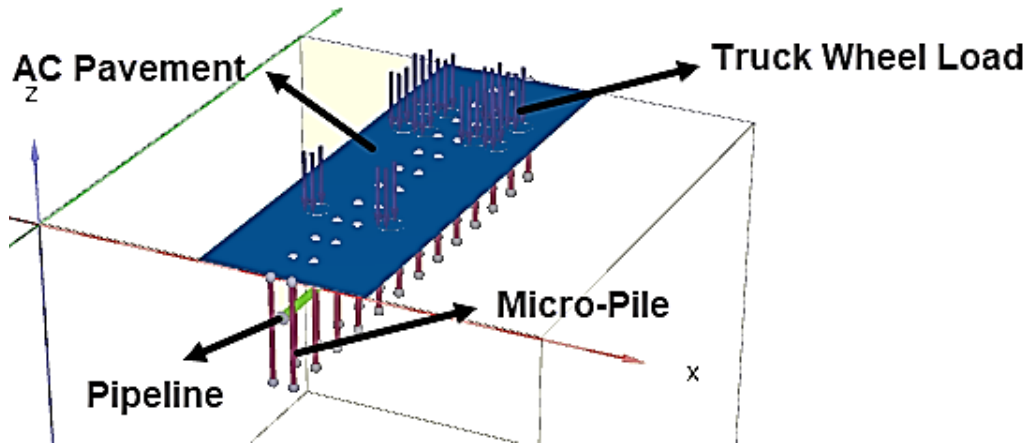

Fig. 1 Numerical Model Setup in case of confining micro-piles configuration

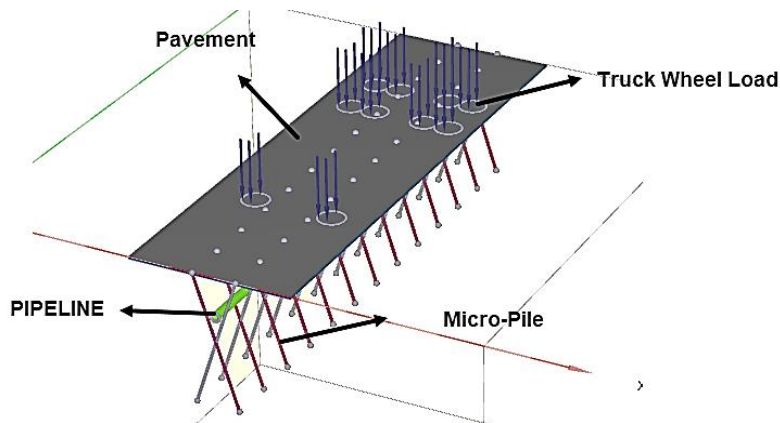

Fig. 2 Numerical Model Setup in case of cross micro-piles configuration

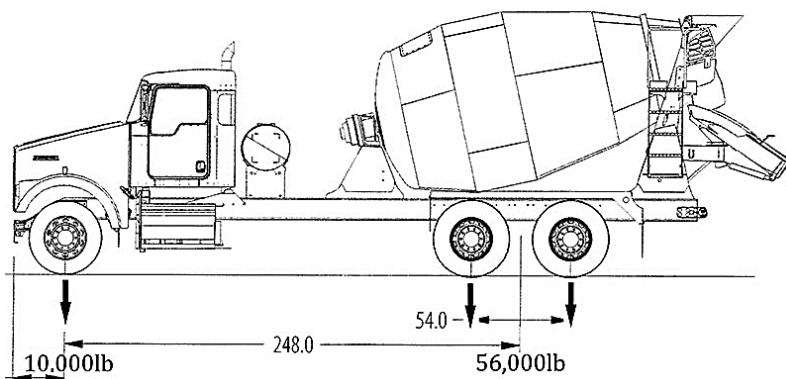
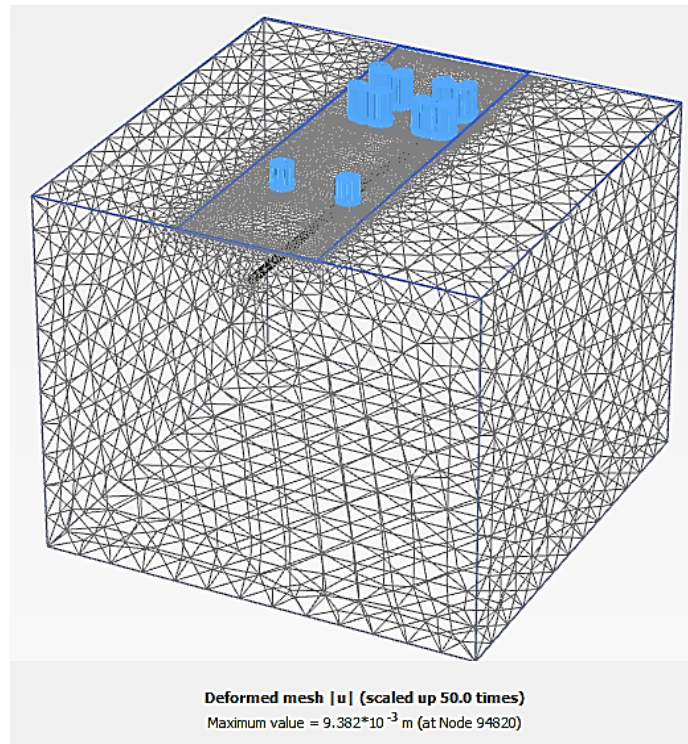
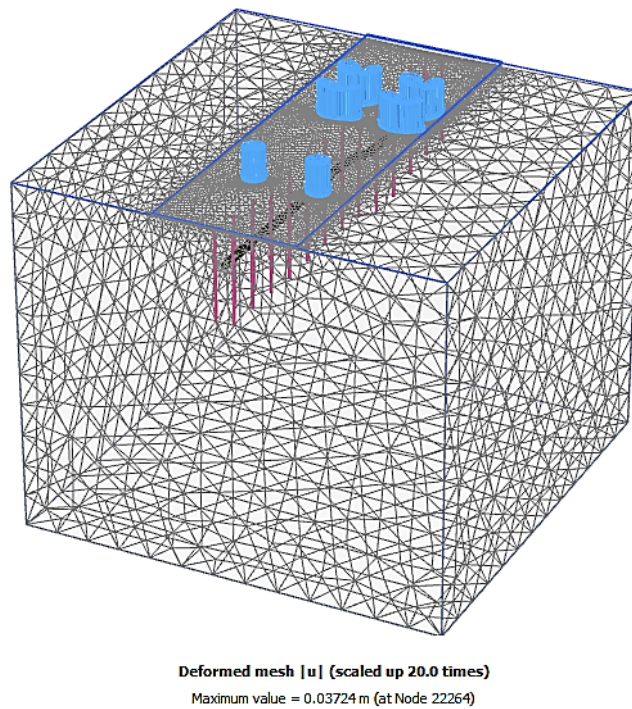

Fig. 3 A typical concrete truck used in the analysis according to [13]

Figures 4,5 and 6 show the deformed mesh in the case of unreinforced soil, reinforced soil with confining and cross micro-piles configurations, respectively. Fig. 7 shows the settlement values of the Pipeline in the case of unreinforced soil.



**Fig. 4** Deformed mesh in case of unreinforced soil



**Fig. 5** Deformed mesh in case of confining micro-piles configuration

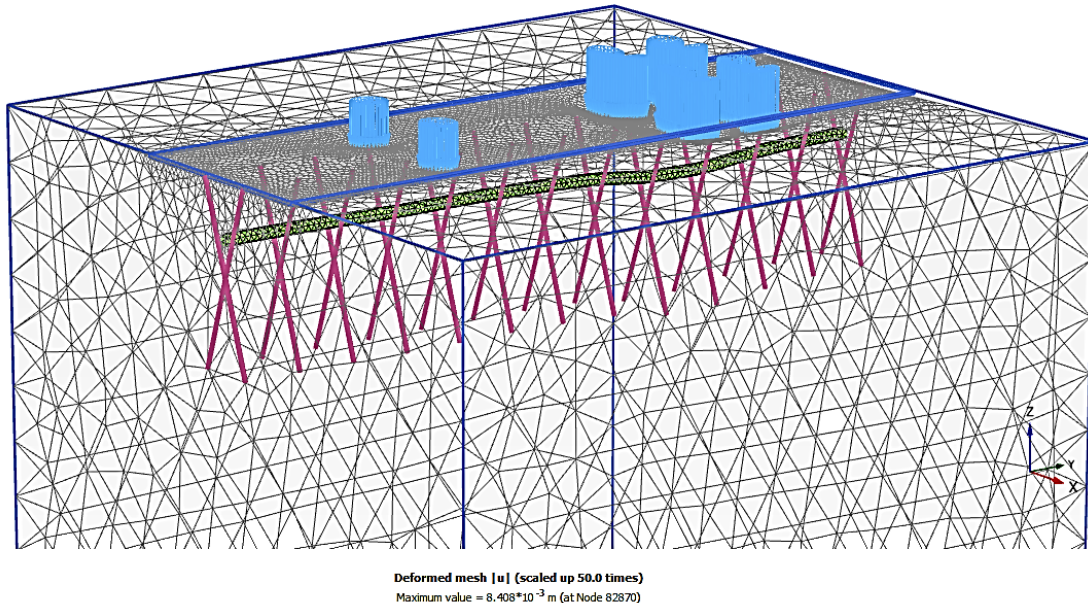

Fig. 6 Deformed mesh in case of cross micro-piles configuration

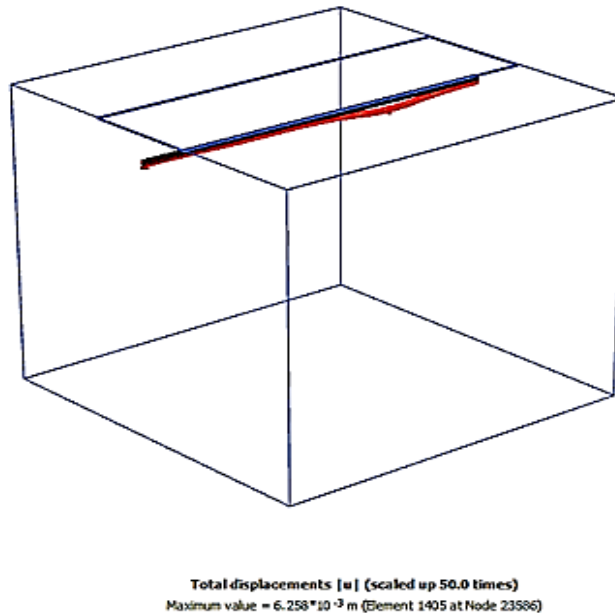

Fig. 7 Settlement of the pipeline in unreinforced soil

Table 1. Parameters of materials used in the numerical model

Parameter	Symbol	Loose Sand Dr =25%	Micro- Pile	PVC Pipeline	Asphalt Concrete Pavement
Unit weight, $\text{kN/m}^3$	$\gamma$	18	25	14.6	25
Young's modulus, $\text{kN/m}^2$	E	10000	$3 \cdot 10^7$	930000	5400000
Angle of internal friction, degree	$\phi$	$30^\circ$	-----	-----	-----
Dilatancy Angle, degree	$\Psi$	$0^\circ$	-----	-----	-----
Cohesion, $\text{kN/m}^2$	C	1	-----	-----	-----
Poisson's ratio	$\nu$	0.3	0.1	0.45	0.35
Diameter, cm	D	-----	10	20	-----
Thickness, mm	t	-----	-----	5	-----

### 4. Results and Discussion

#### 4.1 Case of using confining micro-piles configuration

The case of using confining micro-piles was studied. The results are shown in Fig. 8. It was observed that using the micro-piles installation as a confining configuration improves the behaviour of buried pipelines. This improvement is due to confining effect especially for piles spacing of 25cm. Also, micro-piles carried a part of the load through the skin friction and end bearing of the micro-piles to deeper soil which reduced the stresses on the pipeline which leads to a reduction of pipeline settlement. The vertical displacements profile in the case of unreinforced soil and reinforced soil are shown in figs. 9, 10.

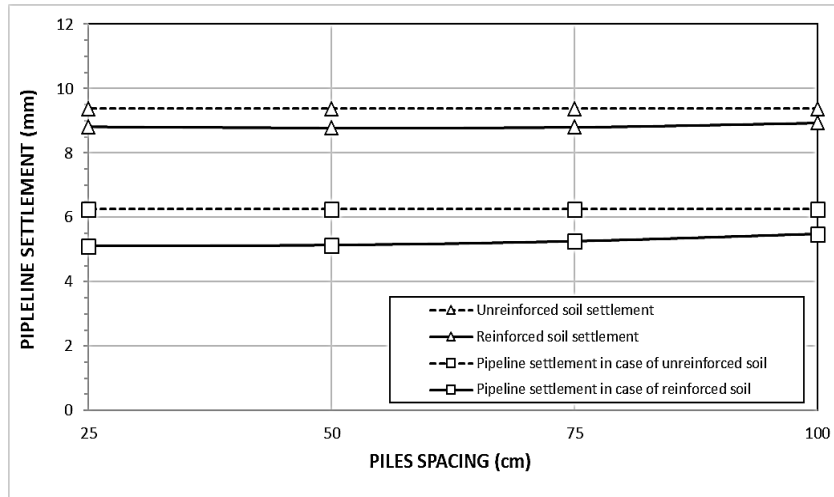

Fig.8 Soil and Pipeline settlement in case of confining micro-piles (Micro-piles diameter = 10 cm and length = 2m)

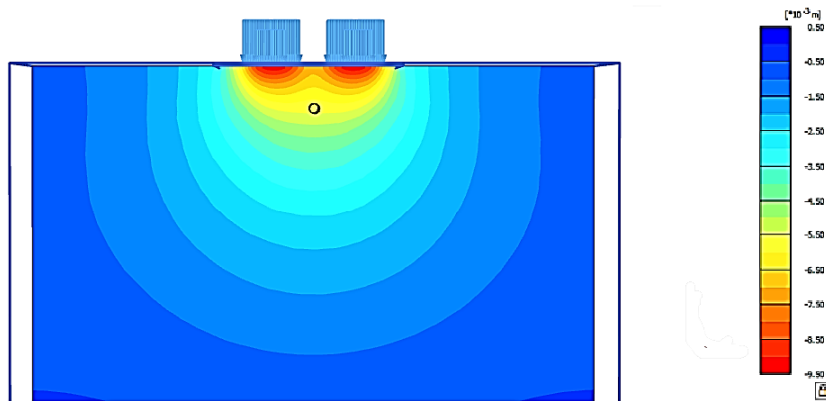

Fig. 9 Vertical displacement in case of unreinforced soil

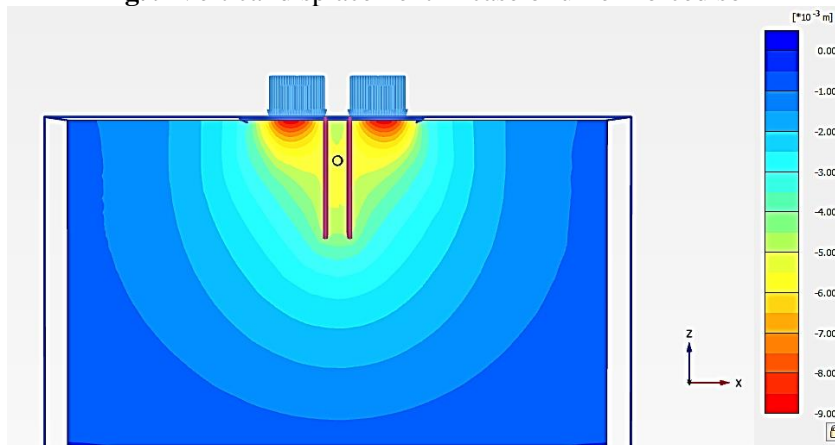

Fig. 10 Vertical displacement in case of reinforced soil with confining micro-piles

### 4.2 Effect of adding water for confining micro-piles configuration

The effect of water leakage on the settlement of soil and the pipeline was studied because in the case of a water leakage the modulus of elasticity of loose sand significantly decreases which leads to the additional settlement of the soil mass and the pipeline. Fig. 11 shows the results in case the soil is inundated by water. It was observed that the pipeline settlement increases considerably.

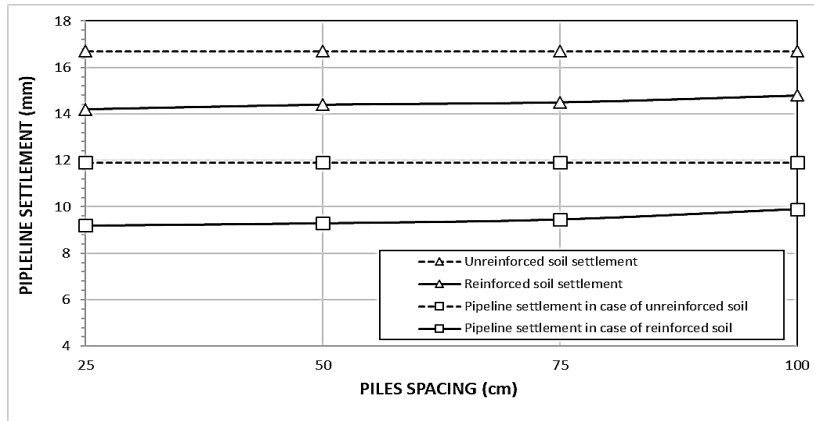

Fig. 11 Soil and Pipeline settlement for different cases (Micro-piles diameter = 10cm)

### 4.3 Effect of micro-piles diameter for confined micro-piles configuration

To obtain the diameter effect on buried pipeline behaviour numerical tests were done for diameters of 10, 15, and 20 cm in the case of piles spacing = 1 m. With the increase in the diameter of micro-piles a slight improvement of buried pipeline behaviour occurs where the amount of the settlement slightly decreases with an increase of piles diameter as shown in Fig. 12.

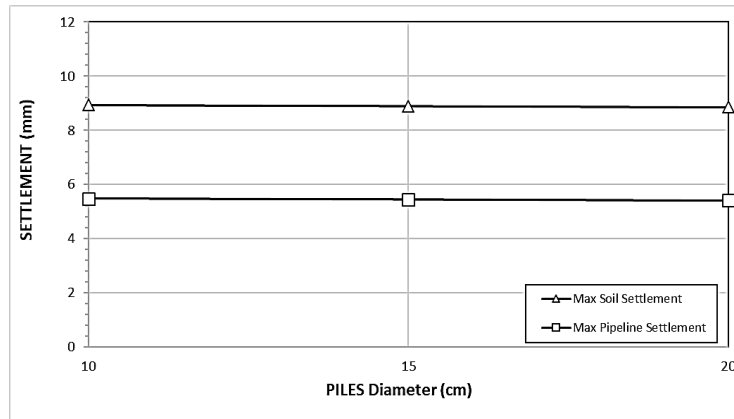

Fig.12 Soil and pipeline settlement for different micro-piles diameter (Micro-piles spacing = 1m)

### 4.4 Effect of micro-piles length for confining micro-piles configuration

To study the effect of piles length on the behaviour of the buried pipeline 2, 3, and 4 m length piles were analysed. From the illustrated results in Fig.13, it was observed that the pile length has a significant effect on decreasing the soil settlement and reducing the strain on the pipeline.



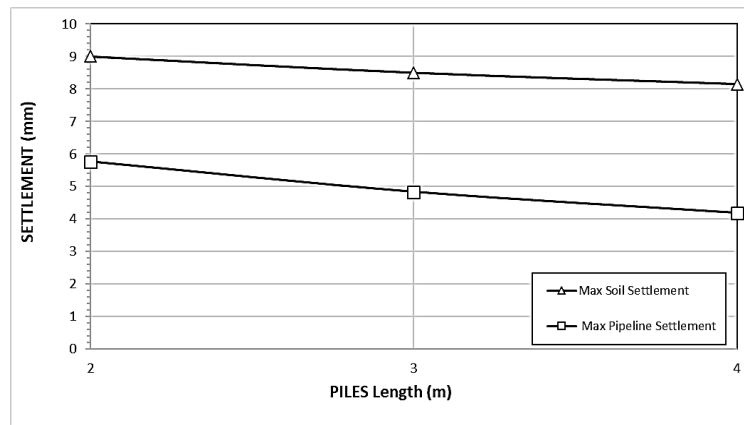

Fig.13 Soil and pipeline settlement for different micro-piles lengths (Micro-piles spacing = 0.25m)

### 4.5 Case of using cross micro-piles configuration

The effect of installing cross micro-piles below the pipeline was studied numerically where, the spacing between micro-piles studied is 1 m, 50 cm, 75, and 25 cm. As shown in Fig.14 which shows the results in the 4 cases it was found that the optimum spacing between micro-piles is 25 cm.

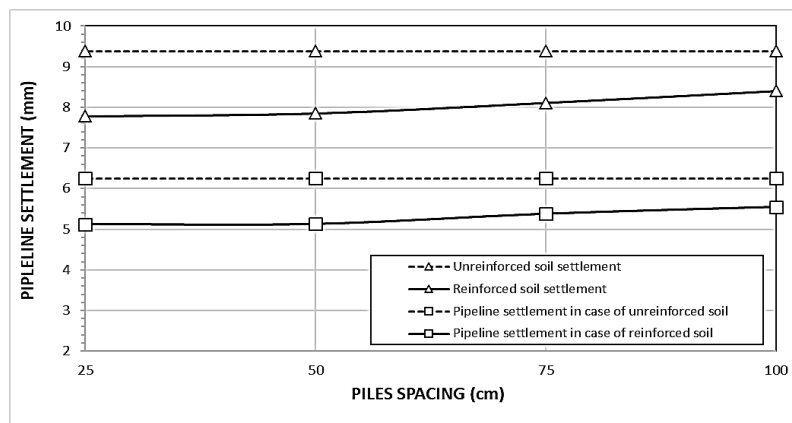

Fig. 14 Soil and Pipeline settlement for different cases (Micro-piles diameter = 10cm)

## 5. Conclusions and Directions for Future Research

Based on the numerical analysis results the following conclusion is obtained:

- Using Micro-piles for reinforcing soil beneath pipelines decreased slightly the settlement of soil and pipelines.
- The optimum spacing between micro-piles was found to be 25 cm for both cross and confined piles configurations for loose sandy soil.
- Inundation of the loose sand with water significantly increases the soil settlement which leads to the additional settlement of the pipelines.
- Micro-piles diameter affects the behavior of buried pipelines where the increase of pile diameter decreases the settlement.
- Micro-piles length affects the behavior of buried pipelines where with an increase of pile diameter it was noted a decrease of the settlement of soil and strains on the pipeline.

## 6. Directions for Future Research

- Other more effective methods of soil improvement under pipelines may be investigated such as using geogrids.
- A comparison of current research results with a real scale field experiments may be investigated.

## 7. References

1. Hernán G. Kunert, José L. Otegui, (2016) “Handbook of Materials Failure Analysis with Case Studies from the Oil and Gas Industry”, 2016.
2. S. A. Naeini, M. Hamidzadeh (2017) “Using Micropiles to Improve the Anzali's Saturated Loose Silty Sand” *Int. Journal of Geotechnical and Geological Engineering*, Vol. 11, No. 7, 2017
3. M. Mollaali, M. Alitalesh and M. Yazdani, (2014) “soil improvement using micropiles”. *Proc. 8 th European Conference on Numerical Methods in Geotechnical Engineering*, Delft, Netherlands 18-20 Jun. 2014.
4. Reza Ziaie Moayed and Seyed Abolhassan Naeini, (2012) “Improvement of Loose Sandy Soil Deposits using Micropiles” *KSCE Journal of Civil Engineering* (2012) 16(3):334-340, DOI 10.1007/s12205-012-1390-2.
5. Pourya Haghighy, (2017), “Improving the Bearing capacity of foundations using micropiles” *International Journal of Advances in Scientific Research and Engineering (IJASRE)*, Vol. 03, Issue 2, March -2017.
6. G.L. Sivakumar Babu, B. R. Srinivasa Murthy, D.S. N. Murthy and M.S. Nataraj. (2012) “Bearing Capacity improvement using micropiles a case study” *Proc. GeoSupport Conference 2004*, Orlando, Florida, United States, [https://doi.org/10.1061/40713\(2004\)14](https://doi.org/10.1061/40713(2004)14), December 29-31, 2004, | Orlando, Florida, United States
7. Bildik, S., Laman M. & Suleiman M.T. (2012) “Parametric studies of buried pipes using finite element analysis” *3rd International Conference on New Developments in Soil Mechanics and Geotechnical Engineering*, 28-30 June 2012, Near East University, Nicosia, North Cyprus.
8. Alireza M. Goltabar and Mohammad Shekarchi (2010), “Investigation of traffic load on the buried pipeline by using real scale experiment and plaxis-3d software” *Research Journal of Applied Sciences, Engineering and Technology* 2(2): 107-113, 2010.
9. Bushra Suhail. Zbar and Hala Hamed. Mohammed Al-Kalali. (2016), “Three-Dimensional Finite Element Simulation of the Buried Pipe Problem in Geogrid Reinforced Soil” *Journal of Engineering*, No.5, Vol. 22 May 2016.
10. Gopika Raveendran and Neena Thomas (2017), “GEONET AS A SOIL REINFORCEMENT SYSTEM FOR THE PROTECTION OF BURIED PIPELINES” *International Research Journal of Engineering and Technology (IRJET)*, Volume: 04 Issue: 04, Apr -2017.
11. Bringreave, Zampich and Ragi Manoj. (2019): “Plaxis 3D Connect edition manual”, Delft University of Technology & PLAXIS bv, The Netherlands.
12. Morteza Esmaeili, Morteza Gharouni and Farid Khayyer (2013) “Experimental and Numerical Study of Micropiles to Reinforce High Railway Embankments” *Int. J. Geomech.* 2013.13:729-744.
13. Rafik R. Gerges and Harsh K. Nisar (2017) “how full can concrete trucks be when driving on slabs-on-grade” *Article structure magazine*, January 2017.
14. *Micropile Design and Construction, Reference Manual*. U.S. Department of Transportation Federal Highway Administration, Publication No. FHWA NHI-05-039, December 2005.
15. Armour, T., Groneck, P., Keeley, J., Sharma, S., FHWA-SA-97-070 - *Micropile Design and Construction Guidelines – Implementation manual: Federal Highway Administration – US Department of Transportation*; 2005.

## تقليل هبوط خطوط المواسير باستخدام الخوازيق ذات الأقطار الصغيرة

### الملخص العربي:

تعتبر التربة الرملية السائبة من أحد أنواع التربة ذات المشاكل لذلك تحدث مشاكل هبوط لخطوط المواسير نتيجة زيادة الاجهادات المؤثرة على خطوط المواسير بسبب الهبوط الإضافي لهذا النوع من التربة عند تعرضها للمياه مما يؤدي الى كسر شبكات المياه او الصرف لذلك يعتبر استخدام الخوازيق الصغيرة لتدعيم التربة مهم لمنع حدوث هذه المشاكل ولسهولة تنفيذ الخوازيق الصغيرة حيث لا تحتاج معدات ثقيلة. تم عمل دراسة باستخدام برنامج العناصر المحددة Plaxis 3D Ver.2020 لسلوك خطوط المواسير في حال تنفيذ خوازيق صغيرة بقطر ١٠ سم لتدعيم التربة لتقليل هبوط خطوط المواسير. تم دراسة سلوك المواسير في حالة التربة غير المحسنة ومقارنتها في حالة استخدام خوازيق متقاطعة تحت خطوط المواسير. أيضا في حالة استخدام خوازيق رأسية بجوار خطوط مواسير المياه. سوف يتم دراسة تأثير كلا من مسافات التباعد بين الخوازيق، قطر الخوازيق، طول الخوازيق على سلوك خط المواسير واستنتاج التباعد الأمثل بين الخوازيق. بالنسبة للأحمال الخارجية تم محاكاة حمل ناتج عن نقل ثقيل (خلاطة خرسانة) وزنها الكلي حوالي ٢٩ طن وحمل المحور الخلف حوالي ١٢ طن. محاكاة حمل العجلات كحمل موزع على دائرة قطرها ٦٠ سم لكل عجلة موزع على طبقة سمكها ٥ سم من الخرسانة الاسفلتية.