

SELF CONTROLLED EXCITATION SYSTEM FOR CONSTANT  
POWER-FACTOR OPERATION OF SYNCHRONOUS MOTOR

H. A. ABOU-TABL      M. M. I. EL-SHAMOTY      S. A. EL-DRIENY

Department of Electrical Engineering,  
EL-Mansoura University, EL-Mansoura, Egypt.

ABSTRACT:

Operation of synchronous motors at constant leading power factor is one of the operation modes, for which synchronous motors may be designed. Under this mode of operation, the generation of reactive power is directly proportional to the active power consumed by the motor. A static excitation arrangement, including an uncontrolled rectifier and a compounding transformer, is one of control systems which are suggested for holding the motor power factor constant.

This paper demonstrates the mechanism of self controllability performed by the compounding transformer which has been modified and constructed in the Electrical Engineering Department, EL-Mansoura University. In addition, the paper gives a suggested equivalent-circuit of the transformer and the corresponding vector diagrams; both at no-load and under load conditions. Thereby the proper compounding effect can be determined.

Results of the laboratory investigations carried out on the test model has been discussed and compared with those obtained under manual control. The self controllability showed by the system in holding the motor power-factor constant, irrespective of the load variation, is a major advantage which may be added to its reliability and simplicity.

INTRODUCTION:

One of the basic advantages offered by synchronous motor drive, is the generation of reactive power. This reactive power is required in large industrial plants to improve the overall power-factor. Synchronous motors are able to supply reactive power, in addition to the developed mechanical power, when they are over-excited. Here, the machine must be designed to work at a leading power-factor and it operates partially as a synchronous capacitor.

In order to minimise the machine currents, both of the armature and the excitation, synchronous motors must be designed to operate at unity power-factor. This way the machine develops mechanical power only and has no responsibility towards reactive power. Such a machine is suggested to work whole the time at rated load.

Away from the unity power-factor operation, the synchronous motor operation can be classified into two types: operation under constant excitation, and operation at constant power-factor. For both types, the machine is suggested to drive a variable load.

In the first type of operation, the motor will operate within a range of leading power-factors. The limits of this range depend on the excitation level, which is assumed to be constant, and the loading range. Under constant excitation, the machine is forced to supply more reactive power when it is lightly loaded. In this case a certain inverse proportionality is existing between the generated reactive power and the developed mechanical power.

In the second type of synchronous motor operation, the reactive power supplied to the network is directly proportional to the active-power demand or the developed mechanical power. It depends mainly on the rated power-factor and the machine current which depends in turn on the required load. In this type of operation, holding the machine power factor constant is established by controlling the field excitation. Here, the field winding must be designed for a range of excitation current. The upper limit of this range depends on both rated power-factor and rated load. Thermal stresses exerted on the field winding at this limit must be taken into consideration.

One of the more economic, simple, and reliable control systems, which are suggested to hold the motor power-factor constant, irrespective of the load variation, is the static excitation system through a compounding transformer [1,2,3]. A modified model of this transformer has been constructed at the electrical machine laboratory of EL-Mansoura University. The model has been employed to build the mentioned control system in conjunction with a 5-KVA, 220-V test synchronous motor.

#### SCHEMATIC DIAGRAM:

Figure (1) shows the basic schematic diagram of a synchronous motor excited from a static exciter which is supplied from infinite busbars through a compounding transformer. The static exciter is mainly an uncontrolled, three-phase, full-wave rectifier bridge. The compounding transformer consists of three different windings: ( i ) current winding, ( ii ) voltage or potential winding, ( iii ) secondary winding. All the three windings are carried on a single core to form one core type transformer. In this transformer, each limb carries a potential-, current-, and secondary-coils which belong to the same phase. Each potential coil, P.C., is connected in series with an external branch formed from a movable core reactor,  $X_R$ , in series with a controlling resistance  $R_C$ .

The potential coils with the external branches form a balanced star connected across the supply terminals. The current coils are connected in series with the lines supplying the machine. Therefore, the current coil, C.C., is equal to the phase current of the machine armature which is star connected ;  $I_C = I_a$ . The secondary windings are connected in star or delta to supply the static exciter which supplies in turn the field current.

A synchronous motor may be commonly started by either of the two following methods :

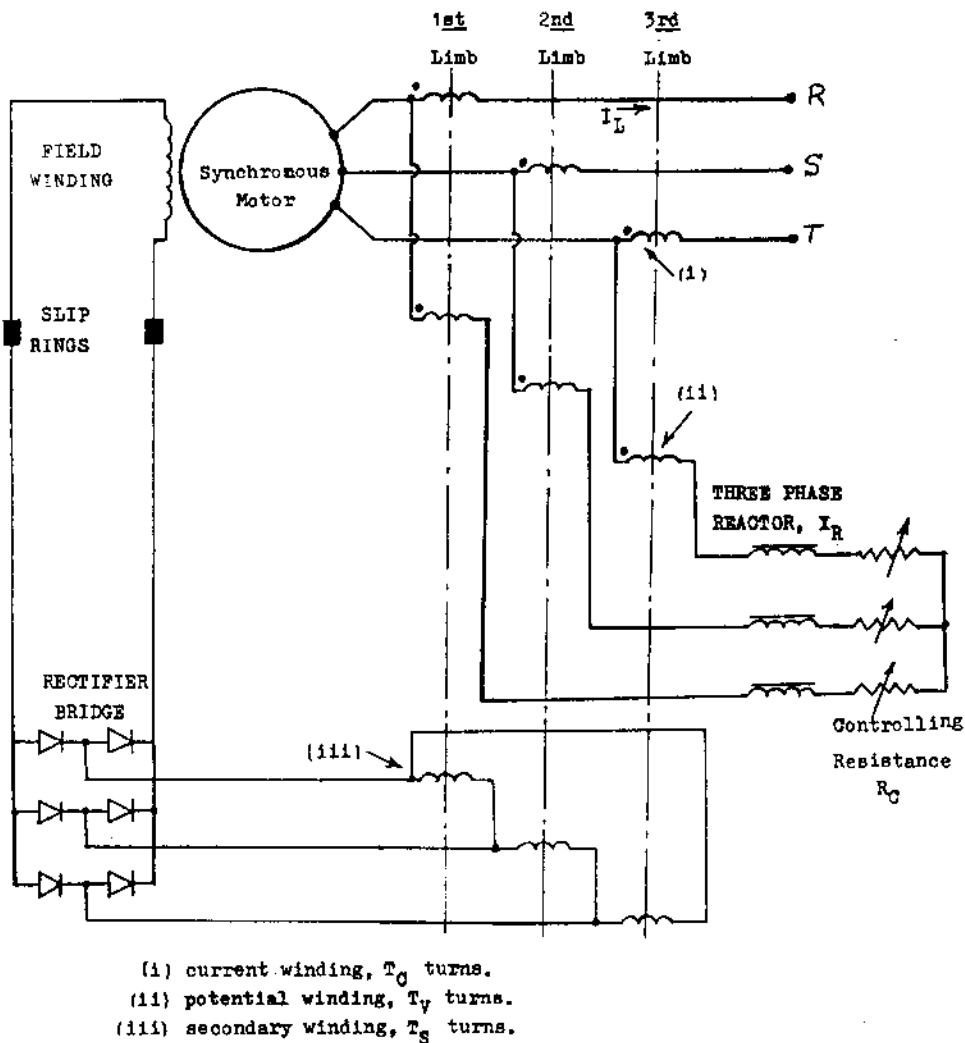

Fig.( 1 ) : Schematic Diagram

1. An auxiliary motor which brings the motor up to the synchronous speed. The synchronous motor is then synchronised to the supply system in the same manner as far the synchronous generators.
2. Direct starting of the machine as in an induction motor by means of a starting winding. This winding can be mainly the damper winding which must here be designed for both machine starting, and damping out speed oscillations due to pulsating load torques. The field winding is short-circuited through a discharge resistor during the starting period and is connected to the static exciter as the motor approaches synchronous speed. If the torque requirements of the load and its inertia do not exceed the pull-in torque of the motor, synchronism will result.

In the first method of starting, the machine will be self-excited through the compounding transformer and the rectifier bridge.

In this case, the potential windings are responsible for establishing the secondary line voltage which must satisfy, through the rectifier bridge, the excitation level required for synchronism. After the machine has been synchronised and the auxiliary motor is being discoupled, the synchronous machine will operate as a motor at no-load and somewhat lagging power factor. In the second method the motor can be of course started under load. The power factor attained just after synchronism, depends on the excitation level offered by the excitation system. In order to domenstrate the controlling mechanism of holding the motor power factor constant; the moment just after synchronisation in the first method of starting will be considered as the start point of analysis.

**CONTROLLING MECHANISM:**

The controlling mechanism performed by the compounding transformer, in order to hold the synchronous motor power-factor constant can be preferably explained by an equivalent-circuit and the corresponding complexor diagram. The suggested equivalent circuit, Fig.( 2), combines mainly between the compounding transformer and the machine. The transformer is assumed to be ideal and therefore, the transformer leakage- and magnetising reactances are not present. The synchronous motor is represented by its synchronous impedance,  $Z_s = r_a + jx_s$ , and the excitation voltage,  $E_f$ .

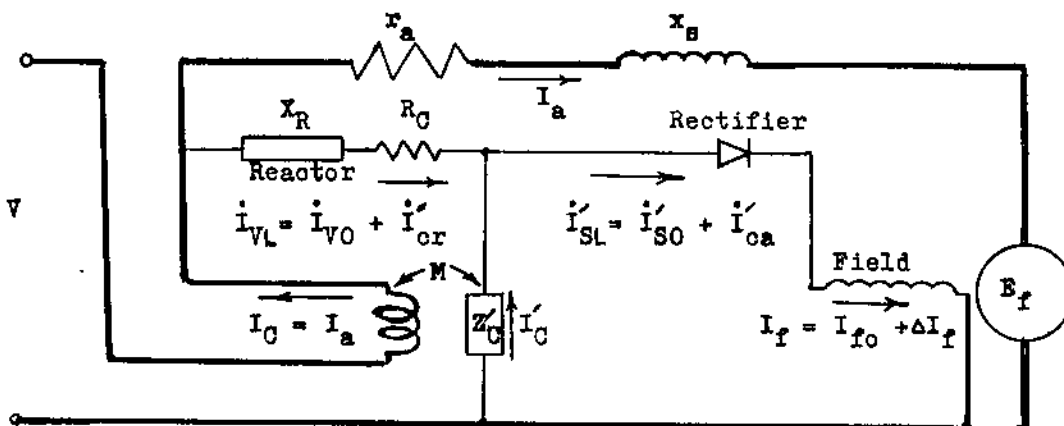

Fig.(2) : Equivalent Circuit.

**No-Load Complexor Diagram:**

After synchronism and the auxiliary motor still coupled, the machine will operate as a floating machine, i.e., it will not consume or supply any current. In this case the induced e.m.f. inside the machine,  $E_{fo}$ , opposes the terminal voltage,  $V$ , and the compounding transformer satisfies the corresponding excitation  $I_{fo}$ .

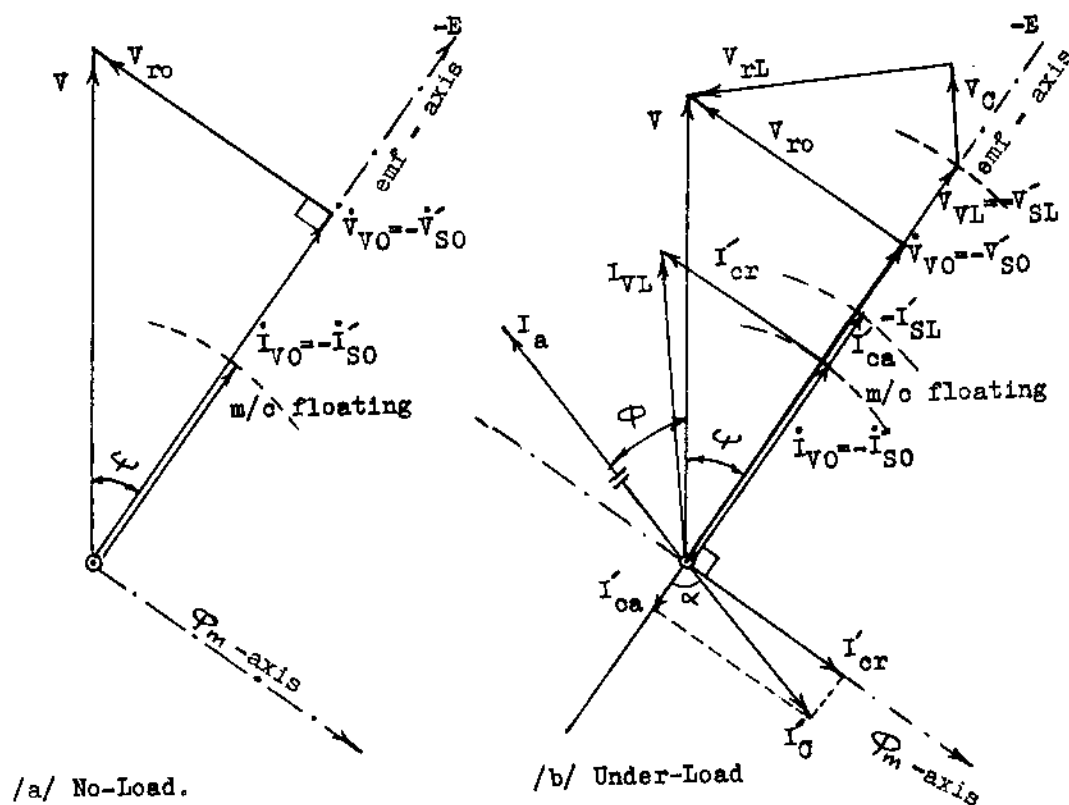

Fig.(3) : Vector Diagram.

In accordance with the transformer operation, this case can be considered as its no-load. As the compounding transformer is assumed to be ideal, Fig. (3-a) gives its no-load complexor diagram referred to the voltage winding. Due to the resistive nature of the field circuit the no-load current of the potential- and secondary- windings,  $I_{vo}$  and  $-I'_{so}$  respectively, are equal and in phase with the no-load voltage of the potential coil,  $V_{vo}$ . These currents are related to  $I_{fo}$  by the transformation ratio,  $a_v = T_v/T_s$ , and the current coefficient of the rectifier bridge,  $K_i$ . The proper number of turns of the potential- and secondary- windings,  $T_v$  and  $T_s$  respectively, can be decided in similar manner as that in reference [ 4 ]. It may be noticed here that small adjustments in the machine terminal voltage before synchronising can be attained by controlling the reactor voltage,  $V_{ro}$ , through the movable core. As it is evident in the complexor diagram, this voltage is in quadrature with  $V_{vo}$ . Under no-load condition, it is also assumed that the current through the current coil,  $I_c$ , is equal to zero. In this case there is no compounding effect and the

voltage winding is responsible alone for providing the required excitation for the machine in floating case.

Complexor Diagram Under Load:

Discoupling the auxiliary motor and the machine is already synchronised, forces it to operate as a motor. In order to explain how the motor will operate at constant power-factor, irrespective of load variation, the complexor diagram under load must be at first declared.

Assuming that the machine is already loaded with a given load at a rated power-factor, the armature current will flow through the current-coil and creates two corresponding currents in both the potential- and secondary-coils. Referring to the suggested equivalent circuit and the corresponding complexor diagram under load, Fig.(3-b), these two currents can be considered as the two components of a balancing current  $I'_C$ . This current will be established mainly in the mutual branch and has its active- and reactive components,  $I'_{ca}$  and  $I'_{cr}$ , along the e.m.f.-axis and the  $\Phi_m$ -axis, respectively.

- Determination of the current-coil number of turns,  $T_C$  :

Having a look at the complexor diagram, Fig.(3-b), it will be seen that the active component  $I'_{ca}$  will be established in the same direction of  $I'_{SO}$ . Also, it will find its path through the secondary-side which may be considered as a resistive circuit due to its nature. Accordingly, the secondary current under load  $I'_{SL}$ , can be obtained as :

$$I'_{SL} = I'_{SO} + I'_{ca} \quad (1)$$

Its value  $I'_{SL}$  is the mathematical sum of  $I'_{SO}$  and  $I'_{ca}$ , and it must satisfy the required excitation level,  $(I_f)_L$ , under the given load and rated power-factor.

This current  $(I_f)_L$  must be a known value from the regulating characteristics of the machine.

Beginning with  $(I_f)_L$  and going back to the potential coil, through  $a_v$  and  $k_i$ , the corresponding value of the secondary current  $I'_{SL}$  will be known. As the value  $I'_{SO}$  is already known, in a similar manner, under the floating condition ; the value  $I'_{ca}$  can be determined as :

$$I'_{ca} = I'_{SL} - I'_{SO} \quad (2)$$

but, from the complexor diagram Fig.(3-b):

$$I'_{ca} = I'_C \cos \alpha$$

or

$$I'_{ca} = I'_c \cos(\psi + \phi)$$

from which the current of the current-coil referred to the potential coil,  $I'_c$ , can be determined as :

$$I'_c = I'_{ca} / \cos(\psi + \phi) \quad (3)$$

In this relation both angles must be known: the first angle  $\psi$  is the phase-shift between  $\hat{V}_{v0}$  and  $\hat{V}$ , and the second angle  $\phi$  corresponds to the rated power-factor. Having the value  $I'_c$ , the proper value of the current coil number of turns,  $T_c$ , can be determined by

$$T_c = I'_c / I_c \cdot T_v \quad (4)$$

where  $I_c = I_a$ .

- Compounding effect :

It is obvious from relation(3) that :

$$I'_{ca} / I'_c = \cos(\psi + \phi) = \text{constant}$$

Therefore the variation in the active component  $I'_{ca}$ , and in turn the exciting current-variation  $\Delta I_f$ , will be proportional to the armature current. Consequently, a corresponding commulative compounding effect is obtained. This effect will be there so long  $(\psi + \phi) < \pi/2$ . If the angle  $(\psi + \phi)$  is equal to or greater than  $\pi/2$ , the compounding effect will finish or will be reversed to be differentially, respectively. Accordingly, the angle  $\psi$  plays a great role in determining the operating power-factor range of the motor in the leading region.

In accordance with the reactive component  $I'_{cr}$ , it will find its path mainly in the circuit consisting of the potential coil, the external branch and the supply. Therefore, the current of the potential coil under load,  $\hat{i}_{vL}$ , can be suggested to be :

$$\hat{i}_{vL} = \hat{i}_{v0} + \hat{i}'_{cr} \quad (5)$$

It is evident from the complexor diagram, Fig.(3-b), that  $\hat{i}'_{cr}$  improves the overall power-factor of the compounding transformer itself. It can be happen that  $\hat{i}_{vL}$  becomes leading.

- Determination of the controlling resistance,  $R_c$  :

Due to the voltage drop caused by the active-component  $I'_{ca}$ , the voltage across the mutual-branch raises from  $\hat{V}_{v0} = -\hat{V}'_{S0}$  to  $\hat{V}_{vL} = -\hat{V}'_{SL}$  along the same axis to reach a point such as m.

The attained voltage corresponds naturally to the required excitation level under load and rated power-factor.

It is, also, naturally known that the voltage across the reactor under load,  $\hat{V}_{RL}$ , must be perpendicular to the current through it,  $\hat{I}_{VL}$ . This voltage  $\hat{V}_{RL}$  must begin under the mentioned condition at the end of  $\hat{V}_{VL}$ , the point m, but it will not meet the end of the terminal voltage  $\hat{V}$ ; if it is required to maintain the rated power-factor constant.

The matching between  $\hat{V}_{VL}$  and  $\hat{V}$  through  $\hat{V}_{RL}$  only will cause the current  $\hat{I}_C$  to rotate towards the voltage  $\hat{V}$ . In turn the motor power-factor will not be maintained constant. To prevent the variation in motor power-factor due to load, proper matching can be achieved by having an additional controlling resistance  $R_C$  in the external branch. It will be connected in series with the reactor. The voltage-drop across this resistance,  $\hat{V}_C$ , in addition to  $\hat{V}_{RL}$  offers the proper matching. This way, the motor power-factor can be maintained constant at rated value; irrespective of load variation.

Having the complexor diagram under rated-load, drawn to scale, and holding the condition that  $\hat{V}_{RL}$  is vertical with  $\hat{I}_{VL}$ , the voltage across  $R_C$  can be determined. Therefore, the controlling resistance can be determined by

$$R_C = V_C / I_{VL} \quad (6)$$

Practically, this resistance can be determined for a range of rated power-factor. Just it has been adjusted under rated load to get a given rated power factor; the machine will operate from no-load to full-load with the same rated power-factor.

#### LABORATORY INVESTIGATIONS :

According to the above suggestions, a laboratory test model of the compounding transformer, as well as the relevant reactors and controlling resistors, have been designed and constructed at the Electrical Machine Laboratory of EL-Mansoura University. The transformer and the mentioned auxiliaries have been used with an uncontrolled three-phase rectifier to build a self controlled excitation system for a 5-KVA, 220-V synchronous motor. As a test model, the system was equipped with the suitable arrangements to drive the motor at a wide-range of rated leading power-factors. The synchronous motor is coupled mechanically with a DC machine, which has been employed to start the first machine as a generator. The excitation required for synchronisation was successfully supplied, through the compounding transformer, from the machine terminals itself in form of a self excited alternator. The small regulations in the machine terminal voltage was performed by adjusting the movable cores of the reactors. The variation in  $\hat{V}_{RO}$  forces  $\hat{V}_{VO}$ , and in turn  $\hat{V}_{SO}$ , to vary in a reverse manner. The excitation level will vary correspondingly to get the required voltage regulation.



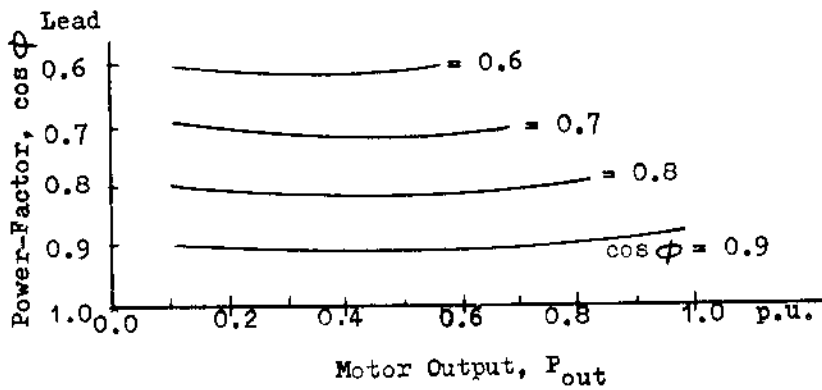
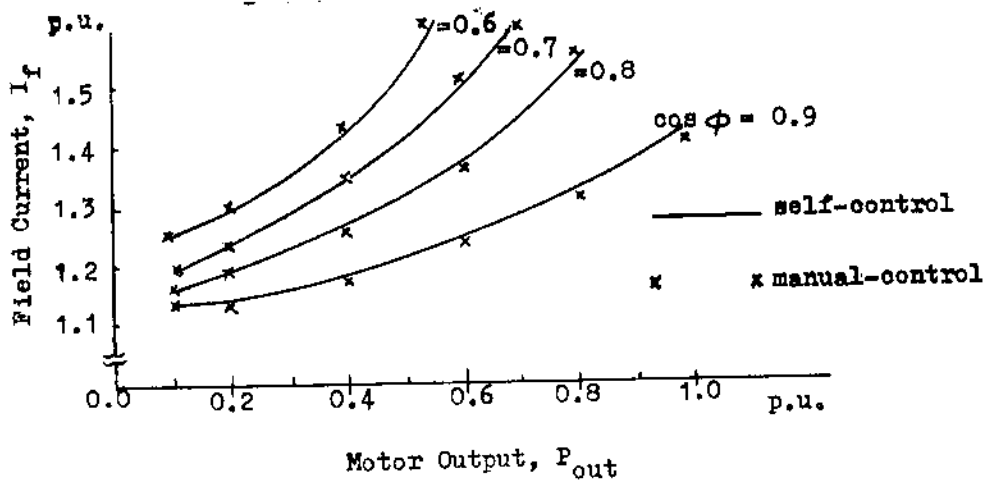

Fig.(4) : Power-factor Constancy.



Fig(5) : Self-controllability of the system.

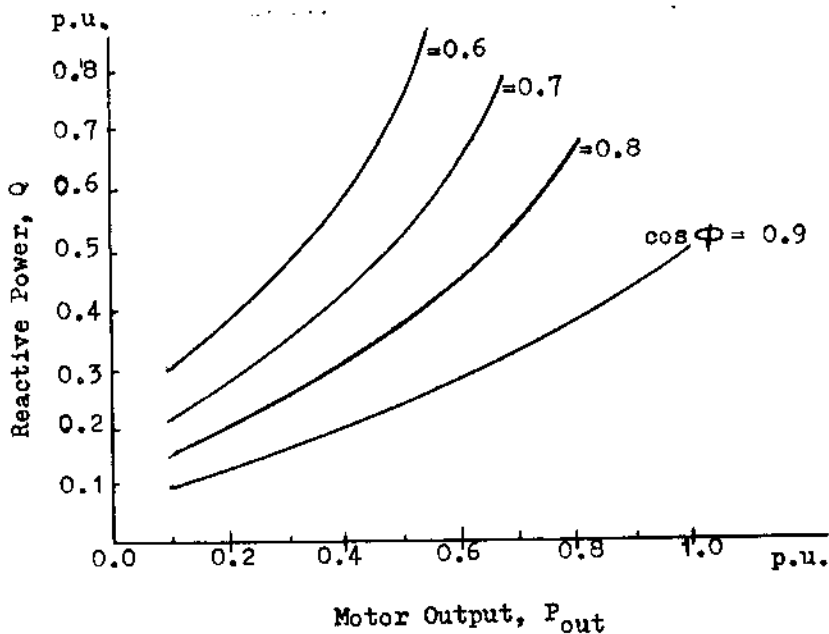

Fig.(6) : Reactive-Power Variation with Load.

After synchronising the main machine, the DC machine was forced, through its excitation, to work as a generator to feed its power back to the DC supply. This way, the synchronous motor can be loaded for a wide range within the rated armature current. If the motor is required to operate at a given power-factor, two different adjustments must be carried out at no-load and rated load. The first adjustment is to be done by varying the reactor voltage, and in turn the angle  $\psi$ , to get the proper no-load matching between  $V_{VO} = -V_{SO}$  and  $V$ . Thereby, the resulting excitation level forces the motor to operate at the given power-factor. Under load and rated armature current, the controlling resistors are to be controlled simultaneously in order to adjust the motor power-factor again to its rated value. Having both adjustments carried out just one time, the given power-factor will be maintained automatically constant; irrespective of load variations. Even the motor is switched off and restarted again, further adjustments are not needed if it is required that the machine operates at previous power factor.

Results of the laboratory measurements taken on the system are given in the Figures (4) to (6). Figure (4) show the power-factor constancy, irrespective of the variation in load, for a group of leading power-factors lies between 0.6 and 0.9. It may be noticed here that each time; the proper number of turns of the current coil must be considered. Therefore, the current winding is provided with suitable tappings.

Figure (5) compares between the manually-controlled and self controlled regulation characteristics of the motor. In the first case, the motor is separately excited from a conventional DC source. The power-factor is held constant, each time, by manual adjusting of the excitation. In the second case, the curves show the steady-state performance of the self-controlled excitation system. They coincide, nearly, the curves obtained by manual control.

As mentioned before, synchronous motor operation under constant power-factor aims mainly to have increasing reactive-power output with increasing mechanical load. Figure (6) presents this relation which seems of course to be of a sinusoidal nature.

Laboratory investigations have also been carried out to replace the three individual resistors by an electronically adjusted single resistor across a three-phase rectifier bridge. Such an arrangement is simple and permits for feed back compensation due to thermal effects in the system.

### CONCLUSION:

Compounding transformer is one of the basic elements of a self-controlled excitation system, which may be used in maintaining the synchronous motor power-factor constant; irrespective of the variation in load. In this paper, the controlling mechanism of such a system has been suggested and discussed to show the necessity of an additional controlling resistor in the external branch. This resistor is required to achieve the proper matching, whole the time, between the transformer input voltage and the

motor terminal voltage. Thereby, the motor power-factor can be maintained constant for a wide range of armature current.

The experimental investigations on the test model show a good constancy of the motor power-factor for a group of values lies between 0.6 and 0.9 lead. The self controllability of the system is approved by comparing its steady-state regulating characteristics with those obtained by manual control. The proposed system offers for the industry a robust, cheaper and more reliable self-controlled excitation system of synchronous motors operation under constant power-factor.

#### REFERENCES:

1. SMITH, I.R. , RAVEN, J.M. and TSO, S.K., "Brushless and Self-Excited Single Phase Alternator", PROC. IEE, 1967, Vol. 114 No. 8 , pp 1089 - 1095
2. SMITH, I.R. and GARRIDO, M.S., "Current Compounded Self-Excitation of Synchronous Motors", PROC. IEE, 1967, Vol. 114, No. 2, pp. 269 - 275.
3. SMITH, I.R. and GARRIDO, M.S., "Current Compounded Self-Excitation Circuits", PROC. IEE, 1966, Vol. 113, No. 11, pp. 1847 - 1848.
4. ABOU-TABL, H.A., EL-SHAMOTY, M.M.I. and EL-DRIENY, S.A., "Approved Design of Self Controlled Static Exciter for an Isolated Alternator", U P E C 85, The 20th Universities Power Engineering Conference, from 2 to 4 April 1985, pp. 263 - 266.