



The effect of nanoparticle and fiber reinforcement on composites used in some applications of internal combustion engine parts

Taghreed B. Alwan¹, Mustafa A. Rajab², Shaimaa A. Hassan³

¹ College of Education, Ibn Al-Haytham, Department of Chemistry, University of Baghdad.

² Technical Institute of Baqubah, Middle Technical University, Iraq

³ College of Remote Sensing & Geophysics, Al Karkh University of Science, Baghdad, Iraq



CrossMark

Abstract

Adding small amounts of nanoparticle reinforcement can lead to the drastic, qualitative improvement of the strength and stiffness of polymers and composite materials. In this study the reinforcement with fibers and nanoparticles was done. We aimed to study the effect of silica nanoparticles, Kevlar and fiberglass on the properties of the composite material contained in the epoxy resin and phenol-formaldehyde (95% / 5%), respectively. The tensile properties are improved after adding phenol formaldehyde to the epoxy material at the ratio (5%). Also, addition of glass fibers improves tensile property with high percentage then carbon fibers, and finally Kevlar fibers have the lowest value. Additionally, nanoparticles such as Alpha aluminum oxide Al_2O_3 that support composite material improve tensile properties. So, it is preferable to use composite materials consisting of epoxy resin and phenol formaldehyde (95/5%) and supported by alpha alumina nanoparticles and glass fibers in the manufacture of the oil sump in the vehicle's combustion engine.

Keywords: Hybrid composite material, properties, Kevlar fibers, glass fibers, silica nanoparticles

Introduction:

It is known that adding small amounts of nanoparticle reinforcement can lead to the drastic, qualitative improvement of the strength and stiffness of polymers. While nanoparticle reinforced materials were expensive up until a few years ago, prices have now started to fall, and their widespread use can be expected in the near future. [1, 2] A composite material is a lightweight compound obtained by mixing more than one material and strengthening it with fibers in one or more directions, in addition to supporting it with nanoparticles. These fibers provide higher stiffness and resistance, Compounds fall into three main classes: particle-reinforced compounds, fiber-reinforced compounds, and structural compounds [3, 4].

The biggest advantage of modern composite materials is that they are light and strong. By choosing an appropriate combination of matrix and reinforcement material, one can make a new material that exactly meets the requirements of a particular application. Composites also provide design flexibility because one can mold many of them into complex shapes. The downside is often the cost. Although the resulting

product is more efficient, the raw materials are often expensive.

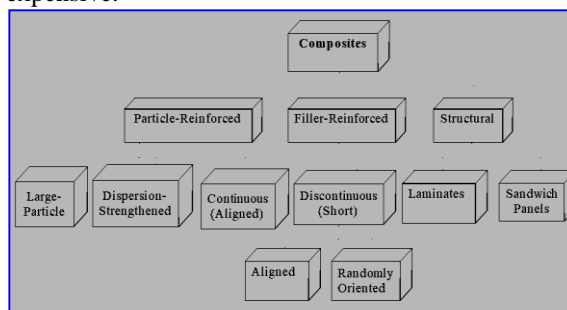

Figure 1: types of composite scheme

The most important main functions when strengthening fibers reinforce composite materials are: They carry most of the forces applied to the composite material and give the property of resistance, So, fibrous materials that have high tensile strength and high modulus of elasticity are often used such as glass, carbon, Kevlar ... etc. [5, 6]. Most polymers that used in engineering applications, are heavily loaded with filler particles (nanomaterials). [7] These particles control both mechanical and physical properties including modulus of elasticity, thermal conductivity,

*Corresponding author e-mail: taghreed.b.a@ihcoedu.uobaghdad.edu.iq (Taghreed B. Alwan).

Receive Date: 21 March 2022, Revise Date: 09 April 2022, Accept Date: 11 April 2022

DOI: 10.21608/EJCHEM.2022.128781.5700

©2022 National Information and Documentation Center (NIDOC)

thermal expansion and density.[8] these particles are such as graphite, silica, and aluminaetc.[9-11] The properties of compounds can be evaluated by applying a simple rule to mixing theories. This formula can be used to evaluate the mechanical and physical properties of composite materials, which may depend on the size and quantity of the particles [12, 13] This can be calculated from the following relationship:

$$p_c = \sum V_i p_i = V_1.p_1 + V_2.p_2 + \dots \text{art } N \quad (1)$$

Where p_c : composite vehicle. p_1, p_2, p_n : density of components. V_1, V_2, V_n : the molecular size of the components.

To calculate the fractional volume of reinforcing materials by volume:[14]

$$V_p = \frac{v_p}{v_c} * 100. \% \quad (2)$$

$$V_m = \frac{v_m}{v_c} * 100. \% \quad (3)$$

Where: V_m, V_p : the volumetric part and the reinforcement respectively.

v_p, v_m, c : the volume of reinforcement of the composite material.[15]

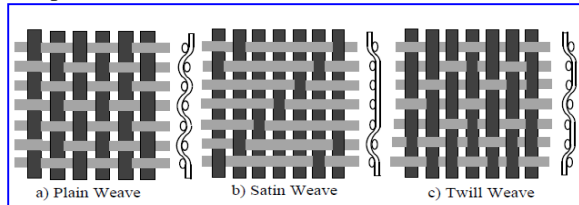

Figure (2): Forms of Woven Fabrics

The fibers consist of fibers directed along two perpendicular directions, one called the torsion and the other called the packing direction. The fibers are woven together, which means that the filler yarn passes over and under the warp threads, following a consistent pattern. Figure (2-a) shows a normal weave as each weave passes over warp yarns and then under warp yarns and so on. In Figure (2-b), each filling thread passes four warp threads before going down the fifth warp thread. That is why it is called "5-belt satin". Figure (2-c) shows a twill weave.[16, 17]

A single anisotropic layer is used, along the x and y direction (see Fig. 2) [18]. The hardness value obtained with the fibers is lower than what was observed if we superimposed two unidirectional cross layers. This is due to the curvature of the fibers during the weaving process, as shown in Figure (3), and this bending makes the fibers more susceptible to deformation than the two crossed layers when exposed to the same load. (There are fibers with a "high modulus of elasticity" where the unidirectional layers are not bound together)[19-21].

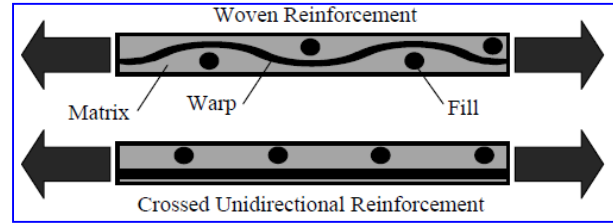

Figure (3): Cross Section of a Layer with Fibers Crossed at 90°C

The samples were weighed before immersion with a sensitive electronic balance, and then the samples were dipped in oil. (7) days later samples were taken. Samples were weighed after drying. This process was repeated every week for one month, then the percentage change in mass was calculated for the samples placed in the oil as follows:

$$Wt \text{ gain } \% = \frac{M_2 - M_1}{M_1} * 100\% \quad (4)$$

Where: M_1 and M_2 : model mass before and after immersion in gram

Alopecia curves were plotted by the absorption ratio with time for all prepared samples.

Absorption percentage curves were plotted with the square root of time for all prepared samples. Zirconium dioxide (ZrO_2), which is also referred to as zirconium oxide or zirconia. There are many different methods of producing ZrO_2 Nano Powders, such as heat treatment, sol-gel treatment, and ion exchange synthesis methods [22]. Pure ZrO_2 appears as three crystalline forms: pure monoclinic zirconia (M) at room temperature, and at this stage it is stable up to (1170 °C), and then transforms into a quadrangular (T) phase under higher temperatures and then to (C) cubic phase at (2370 °C) as shown in Fig. (4) illustrates ZrO_2 nanoparticles in three major crystal structure phases: (a) cubic, (b) quadrangular and (c) monoclinic[23]. Zirconia is used in various fields of chemistry, especially ceramic materials, and zirconia nanoparticles are of great importance due to their resistance, high connections, and durability properties, low reactivity, in addition to a high melting point (2715 °C), which leads to mechanical and physical properties represented by thermal and electrical performance. And optical performance[24].

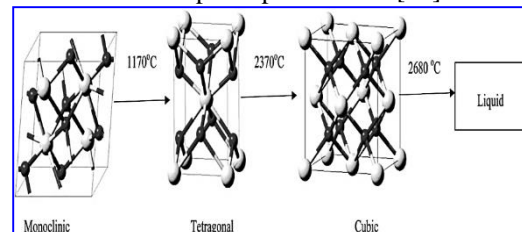

Figure (4): Illustration of three polymorphs of ZrO_2 : (a) cubic, (b) tetragonal and (c) monoclinic

Magnesium oxide (MgO) is a suitable material for thermal insulation applications due to its high melting point (2850 °C). Therefore, MgO is used as an insulating layer. MgO is obtained by thermal decomposition of different magnesium salts. Figure (5) shows the crystal structure of cubic magnesium oxide, and due to its properties of dielectric constant compared to the insulating layer one of the most common applications of magnesium oxide particles is in the fields of electronics and coatings [25, 26].

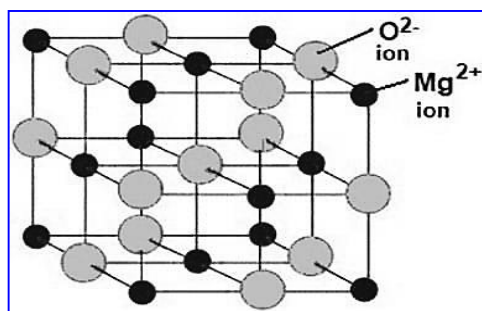

Figure (5): Molecular structure of a magnesium oxide (MgO) nanoparticle

According to above survey, the aim of our work is using epoxy resin with formaldehyde in different mixing ratio to study the mechanical properties of the hybrid composite material reinforced with fibers (glass, carbon, Kevlar) and nanoparticles (alpha alumina Nano), and the possibility of replacing them with materials from some mechanical parts of the

combustion engine and comparing it with previous results. One of the parts of the combustion engine, which is the engine oil sump, was selected as part of the study as shown in Figure (6). A simulation program was used, where the composite materials used in the research were tested and compared with an alloy from which the part was originally manufactured.

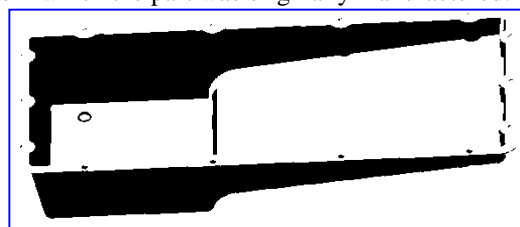

Figure (6): Oil basin in internal combustion engine

Experimental Method

- As shown in Figure 7, both epoxy resin 95% and phenol formaldehyde resin 5% were mixed in molar ratio. Epoxy resin (EP) is solvent-free, liquid component and low viscosity, at 30 °C, for glass fibers (bi-glass fibers). Axis 0/90), in addition to carbon fibers, Kevlar-9) fibers were also used. Also, Table 1 shows the properties of fibers and particles such as alpha aluminum oxide particles that used for strengthening the composite material.

Material	Composition
Epoxy resin	95 wt. % 94.7wt.5 94.5wt. %
Alumina nanoparticles	0 wt. % 0.3wt. % 0.5wt. %
Resole	5 wt. % 5wt. % 5wt. %

Figure (7): used materials

Table (1): Shows the properties of the fibers used in the current study.

Property	Tensile strength	Compressive strength	Elastic modulus	Density (g/cm ³)
E-glass	3444(MPa)	1080(MPa)	72(GPa)	2.6
Carbon fiber	(3–6.5 GPa)	(1–2.7 GPa)	(200–900 GPa)	1.8–2.0
Kevlar fiber	2761.0(MPa)	516.9(MPa)	151.9(GPa)	1468(kg/m ³)

- Epoxy and phenol formaldehyde sheets reinforced with fibers and nanoparticles were prepared. The casting mold is made of glass panels with dimensions (200 x 200 x 4 mm). Nylon sheets are placed below the casting mold to prevent the composite material from sticking. The epoxy resin and hardener are mixed manually to obtain a suitable mixing ratio, by mechanical stirrers for 20 minutes to obtain a good homogeneity between epoxy resin and phenol formaldehyde resin. The epoxy resin and phenol-formaldehyde resin were weighed to obtain a suitable mixing ratio, after which the filler was added in an appropriate mixing ratio to obtain a homogeneous hybrid resin (Table 2).

Table (2): Hybrid Blind mixing ratio of Epoxy risen and resole resin

No.	mixing ratio of Epoxy risen	mixing ratio of Resole resin
1	100%	0%
2	95%	5%
3	90%	10%
4	85%	15%
5	80%	20%
6	70%	30%
7	60%	40%
8	50%	50%

- The mixture of 90% epoxy resin with 10% phenol formaldehyde was mixed well to obtain homogeneity between hybrid resin and steel and also to remove air bubbles trapped in the sample. The weighted portion of the materials used was obtained by weighting Kevlar fibers, carbon fibers or glass fibers in the hybrid resin mixture and then spreading the hybrid compound into the mold. The first layer of hybrid resin was laid down and then sawn, then fiber spread. Then the process is repeated for the second layer, where a toothed steel roller is used to flatten the mixture well. After completing the preparation of the reinforced composite material, the engine oil container was selected as part of the study and the material that was manufactured in the current study was replaced with this specific part, and a simulation program was used, where the

composite material was used in the research was tested and compared with the alloy (Fig. 8), for purpose of weight loss and improvement of properties by strengthening with fibers and nanoparticles.

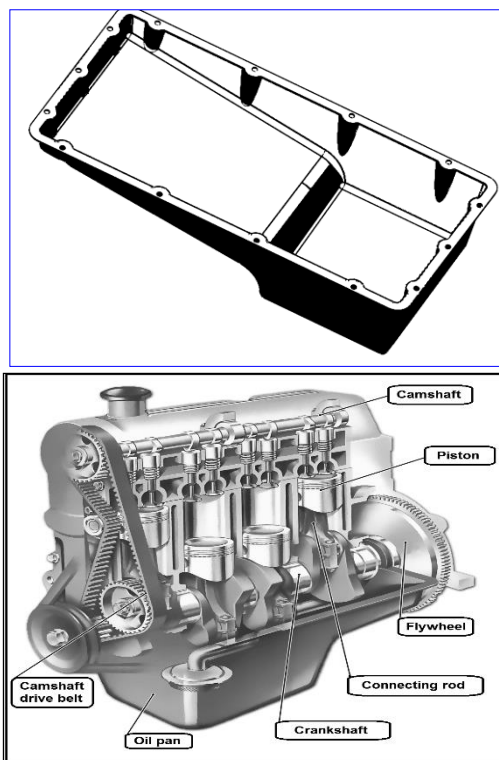

Figure (8): Oil Pan in the Vehicle's internal Combustion Engine.

Results and Discussion

Mechanical properties are the most comprehensive of any material known for its ability to with stand external conditions, represented by tensile strength, which is the maximum energy it can withstand before it breaks under shock stress. As for the tensile strength in the current study, the resin is a brittle material, where its tensile strength is low, but when the reinforcing material is added in different proportions, the tensile strength improves significantly, and the composite material becomes able to withstand external forces, and the tensile strength inside the resin increases, allowing Better distribution of the load, as shown in Figure (9).

The results obtained from the finite element analysis of the composite mixture used in the manufacture of the oil sump for the internal combustion engine of the vehicle, gave the value of the design stress ... a visualization that the composite material supported by nanoparticles used in the current study falls in the safety zone, and we also found a slight change in the

dimensions of The oil basin in the mixtures, which indicates the possibility of obtaining fixed dimensions.

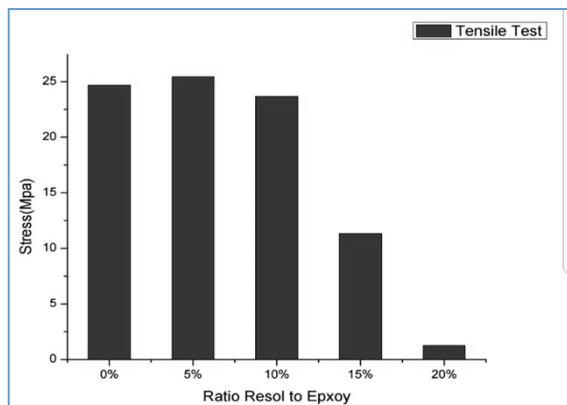

Figure (9): Stress of composite material with deferent Resole to Epoxy.

Figures (10-a, b) illustrate the distribution network of the elements using the finite element technology of the oil basin used as a model for the current study, in which it shows the distribution of stresses on the section of the part after replacing the composite material supported by nanomaterials Instead of the original article.

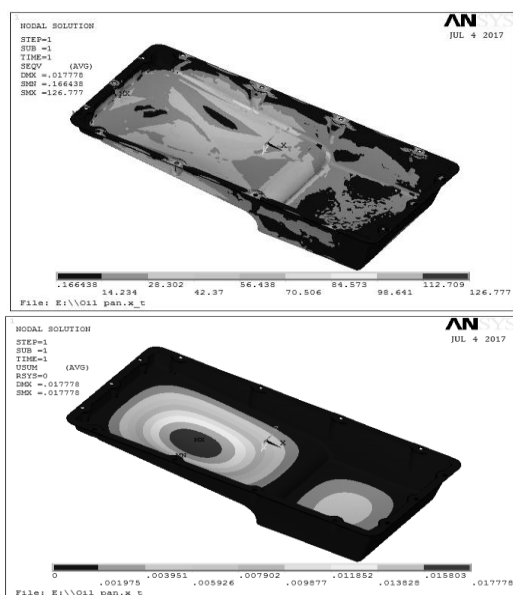

Figure 10: (a) Deformation of oil pan material, (b) Stress of oil pan material.

The tensile test was studied for different resole ratios. It is clear that the maximum tensile strength was obtained with a maximum value of Resole. This can be attributed to the solid cross bonding of the Resole-Epoxy chain. Epoxy and Resole are generally known to be hard and brittle materials, cracking brittle, but epoxy is harder than Resole, so the mixture (90%

Epoxy + 10% Resole) has a maximum value (47.3 MPa) for ultimate tensile strength compared to a mixture (60 % Epoxy + 40% Resole) has a minimum value of maximum tensile strength, which means that a certain percentage of phenol formaldehyde is added to the epoxy in order for the process to improve in the properties

Conclusions:

According to above results we can concluded that adding small amounts of nanoparticle reinforcement can lead to the drastic, qualitative improvement of the strength and stiffness of polymers and composite materials. In this study the reinforcement with fibers and nanoparticles was done. With results that obtained to afford that the effect of silica nanoparticles, Kevlar and fiberglass on the properties of the composite material contained in the epoxy resin and phenol-formaldehyde is with ratio 95% / 5%, respectively. The tensile properties are improved after adding phenol formaldehyde to the epoxy material at the ratio (5%). Also, addition of glass fibers improves tensile property with high percentage then carbon fibers, and finally Kevlar fibers have the lowest value. Additionally, nanoparticles such as Alpha aluminum oxide Al_2O_3 that support composite material improve tensile properties. So, it is preferable to use composite materials consisting of epoxy resin and phenol formaldehyde (95/5%) and supported by alpha alumina nanoparticles and glass fibers in the manufacture of the oil sump in the vehicle's combustion engine.

References

- [1] F. Qiu, T.-s. Liu, X. Zhang, F. Chang, S.-l. Shu, H.-y. Yang, Q.-l. Zhao, Q.-c. Jiang, Application of nanoparticles in cast steel: An overview, *China Foundry* 17(2) (2020) 111-126.
- [2] J. Tu, N. Wang, Y. Yang, W. Qi, F. Liu, X. Zhang, H. Lu, M. Liu, Preparation and properties of TiB₂ nanoparticle reinforced copper matrix composites by in situ processing, *Materials Letters* 52(6) (2002) 448-452.
- [3] E.J. Barbero, Introduction to composite materials design, CRC press 2010.
- [4] X. Li, C. Mittelstedt, A. Binder, A review of critical issues in the design of lightweight flywheel rotors with composite materials, *e & i Elektrotechnik und Informationstechnik* (2022) 1-18.
- [5] J. Sun, L. Qian, J. Li, Toughening and strengthening epoxy resin with flame retardant molecular structure based on tyrosine, *Polymer* 230 (2021) 124045.
- [6] S.A. Hassan, S.M. Lateef, I.Y. Majeed, Structural, Spectral and Thermal studies of new bidentate

- Schiff base ligand type (NO) derived from Mebendazol and 4-Aminoantipyrine and its metal complexes and evaluation of their biological activity, *Research Journal of Pharmacy and Technology* 13(6) (2020) 3001-3006.
- [7] M. Nikzad, S.H. Masood, I. Sbarski, Thermo-mechanical properties of a highly filled polymeric composites for fused deposition modeling, *Materials & Design* 32(6) (2011) 3448-3456.
- [8] H. Dilbas, M. Şimşek, Ö. Çakır, An investigation on mechanical and physical properties of recycled aggregate concrete (RAC) with and without silica fume, *Construction and Building materials* 61 (2014) 50-59.
- [9] M. Rajab, A.-H. Hameed, Hardness and Wear Resistance of Composite Materials Reinforced by Silica, Graphite and Carbon Fiber, of the International Congress of the Water Management, Energy, Food and Agricultural Techniques Istanbul Turkey, 2017, pp. 7-10.
- [10] Y. Kim, M. Kim, H.-G. Seong, J.Y. Jung, S.-H. Baek, S.E. Shim, Roles of silica-coated layer on graphite for thermal conductivity, heat dissipation, thermal stability, and electrical resistivity of polymer composites, *Polymer* 148 (2018) 295-302.
- [11] M.L. Rinawa, R. Sharma, P.R. Baviskar, R. Sampathkumar, R.G. Deshmukh, M.V. Rao, R. Subbiah, Study on wear properties of Aluminium alloy for different mass of SiC particles, *Materials Today: Proceedings* (2022).
- [12] D. Hale, The physical properties of composite materials, *Journal of materials science* 11(11) (1976) 2105-2141.
- [13] M. Magri, L. Adam, J. Segurado, Particle size effects in ductile composites: An FFT homogenization study, *Journal of the Mechanics and Physics of Solids* (2022) 104759.
- [14] M. Hao, W. Zheng, W. Chang, Compression behavior of reinforced concrete columns jacketed with multi-spiral transverse reinforcement, *Structural Concrete* (2022).
- [15] M.M. Stănescu, A. Bolcu, A Study of the Mechanical Properties in Composite Materials with a Dammar Based Hybrid Matrix and Reinforcement from Crushed Shells of Sunflower Seeds, *Polymers* 14(3) (2022) 392.
- [16] C. Tong, Process and Material Characterization in Printed Flexible Electronics, *Advanced Materials for Printed Flexible Electronics*, Springer 2022, pp. 53-117.
- [17] K. Bilisik, Multiaxis three dimensional (3D) woven fabric, *Advances in modern woven fabrics technology* (2011) 79-106.
- [18] F. Xia, H. Wang, Y. Jia, Rediscovering black phosphorus as an anisotropic layered material for optoelectronics and electronics, *Nature communications* 5(1) (2014) 1-6.
- [19] A.J. Obaid, L. Ahmed, One-Step Hydrothermal Synthesis of α -MoO₃ Nano-belts with Ultrasonic Assist for incorporating TiO₂ as a NanoComposite, *Egyptian Journal of Chemistry* 64(10) (2021) 3-4.
- [20] M.E.S. Hassan, J. Bai, D.-Q. Dou, Biopolymers; definition, classification and applications, *Egyptian Journal of Chemistry* 62(9) (2019) 1725-1737.
- [21] M. Albozahid, S. Mateab, Study the effect of adding mwcnts on the hardness, impact strength, and structural properties of composite materials based on epoxy polymer, *Egyptian Journal of Chemistry* 65(3) (2022) 1-2.
- [22] G. Imanova, T. Agayev, S. Jabarov, Investigation of structural and optical properties of zirconia dioxide nanoparticles by radiation and thermal methods, *Modern Physics Letters B* 35(02) (2021) 2150050.
- [23] S. Liu, H. Wang, Y. Wei, R. Zhang, S. Royer, Morphology-oriented ZrO₂-supported vanadium oxide for the NH₃-SCR process: importance of structural and textural properties, *ACS applied materials & interfaces* 11(25) (2019) 22240-22254.
- [24] C. Hu, J. Sun, C. Long, L. Wu, C. Zhou, X. Zhang, Synthesis of nano zirconium oxide and its application in dentistry, *Nanotechnology Reviews* 8 (2019) 396-404.
- [25] C. Shao, H. Guan, Y. Liu, R. Mu, MgO Nanofibres via an Electrospinning Technique, *Journal of Materials Science - J MATER SCI* 41 (2006) 3821-3824.
- [26] 8. Properties of Materials Used in Vacuum Technology**Part 8 is by Shapira and D. Lichtman, in: G.L. Weessler, R.W. Carlson (Eds.), *Methods in Experimental Physics*, Academic Press 1980, pp. 345-423.