

The influence of Hassan Fathy architecture on modern housing trends within the city pattern

Original
Article

Abdel-Wahab Adel El- Kadi

The Architectural Department, Collage of Engineering and Technology, Arab Academy for Science, Technology and Maritime Transport, Latakia, Syria

Keywords:

Applications and design features, city patterns, Hassan Fathy's architecture, inner green spaces, vernacular architecture.

Corresponding Author:

Abdel-Wahab Adel El-Kadi, The Architectural Department, Collage of Engineering and Technology, Arab Academy for Science, Technology and Maritime Transport, Latakia, Syria, **Tel:** 00201001100056, **Email:** abdelwahabelkadi62@gmail.com

Abstract

Hassan Fathy - one of the Egyptian pioneer architects for his interest in the architecture of the poor that gave him international reputation – his works are highly adapted with the foundations of sustainable and green architecture. Hassan Fathy designs are to consider the use of: an inner courtyard for natural ventilation and lighting, thick walls as bearing walls to transfer the loads of the ceilings, which are from vaults and domes. The air catcher is also used to cool the air inside the spaces that could assist in energy conservation, in addition to the use of the Mashrabiya, the well-known Islamic ornamented element. Privacy (separation between visitors and residence circulation) seems to be one of his design obligations. Hassan Fathy system of construction has been criticized for: the building height is limited to 2 to 3 floors, due to the use of load-bearing walls and also to suit the natives building methods. This limited its application only to open areas, villages or at desert. This article proposes an application for using Hassan Fathy system of construction inside the city.

I. INTRODUCTION

Hassan Fathy a famous world wide Egyptian architect, when reading his book “Architecture for the Poor”; we could investigate three points: 1st point is that societies that lose their heritage can easily lose their identity. 2nd point is that forms of construction imported from abroad do not

suit our Arab city’s needs. However, the 3rd one balanced between his intension for both the heritage and the modern styles in his structures.

“We Shape our Building... Where thereafter they Shape us,” Sir Winston Churchill, former UK prime minister said after World War 2, Hassan Fathy believes on these words as he discussed in his aforementioned book.^[10]



Fig. 1: Towers in Cairo with a western character in shape and design

I.1. Research problem (Hypothesis):^[9]

The article examines the criticism commented to Hassan Fathy's architecture: "although it is environmental, sustainable and energy saving, but it is difficult to be implement in the city". Hassan Fathy buildings types of were used to be built from 1 to 3 floors high, building walls are thick, mostly adaptable to be established in open desert areas. The article studies and suggests the possibility of applying Hassan Fathy's architecture in a repetitive multi-story form structure.

I.2. Research objective:

Based on Hassan Fathy principles, design bases and construction criteria that been applied in his buildings, the author studies the possibility of using Hassan Fathy's goals in dwelling units, which to be placed above each other taking vertical concept, in a multi-story aspect form. In addition, the paper investigates the following major points:

- The paper provides functional spaces required for three different dwellings models.
- The author discuss wall materials and construction technology, in order to consider economic aspects of construction.
- Adaptation of green architecture design basis adaptation "environmental construction" are considered
- The paper proposes 3 residential housing models differ in both total area together with its design requirements.
- The research consider structures shape, and design concept variation.

II. Theory

II.1. Hassan Fathy architectural design concept criteria: ^[1]

Hassan Fathy design aspects typology adaptation, are due to be consider:

1. Great Human Value architecture: the building environment is a matter (the use of inner courtyard + air catcher)
2. Privacy rules, (family spaces i.e., bedrooms and family living room, are to be separated from visitor's spaces).
3. Technology ought to be compatible with the environment: technology must be applied in a way that corresponds to both users and environment, and must be controlled by what Hassan Fathy called (innate knowledge), where all architects are to make scientific methods respond to human needs.

II.2. Climatic characteristics of Hassan Fathy buildings:

Hassan Fathy Building characteristics due to prevent heat

transfer by using the following:

1. Thick walls 40-60cm.
 2. Indoor courtyards.
 3. Vaults and domes
 4. Clay bricks (for its high-insulated properties).
 5. Air catchers
- ### 2.3. Hassan Fathy Structure Design Components:
- #### 2.3.1. Inner courtyard:^[2]

- An open roof indoor space
- Inner courtyard regular planes are regular in shape (rectangular or square)
- The courtyard area proportion are range from 30% to 50% from dwelling planes total area.
- Such courtyards are due to have green and water spaces.

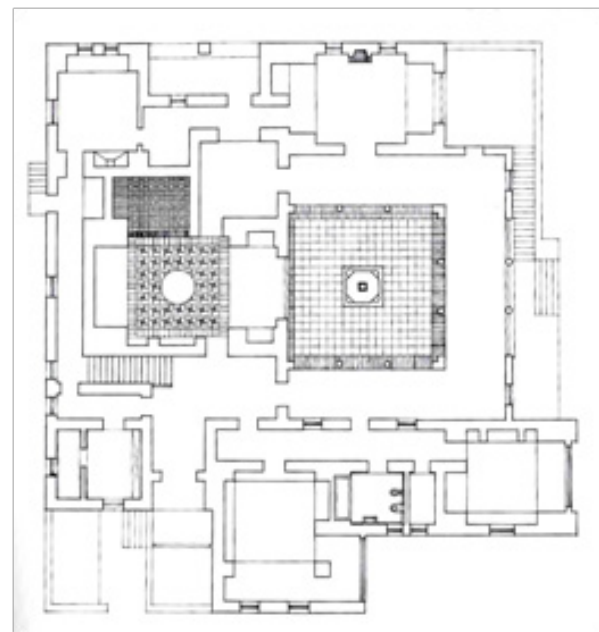

Fig. 2: A house with an inner courtyard

II.3.2. Mashrabiya:

- The Mashrabiya is An Oriental window used to be built in ancient years.
- A wooden structure, shown by figure 4, that protrudes horizontally from the wall toward the street direction
- It is constructed to let house females sit unwatched.
- The Mashrabiya is mostly a nonglazed structure.
- It provides the inner space with the enough shade needed.



Fig. 3: Mashrabiya

II.3.3. Vaults and domes:

Hassan Fathy employed Mud bricks as construction material, for his vaults and dome's structure.

II.3.4. Air Catchers

Hassan Fathy, intended to use Air catchers, treatments are used at ancient Islamic ears (Mamluks and Osmanian), intended to cool down hot air. However such treatment intended to over come the hot climate conditions.

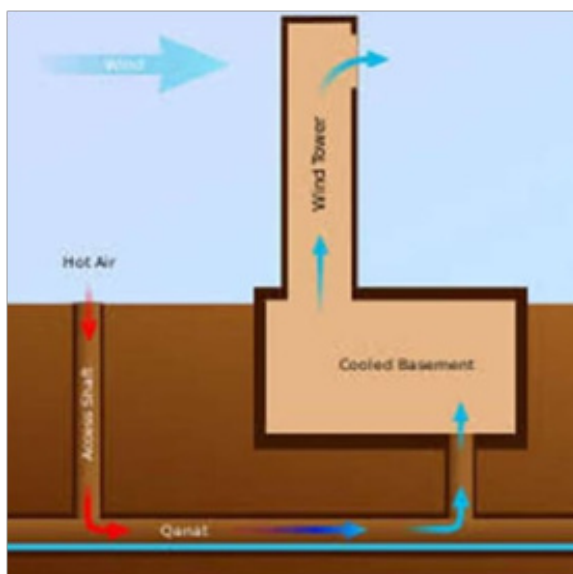

Fig. 5: Air catchers details.

II.4. Examples of Hassan Fathy Building:

II.4.1. Nazli Caseroni Palace:^[3]

Table (1) shows Nazli Caseroni's Palace information about location, area, and floors elements.

Location	Shabramant - Giza - Egypt
Construction Material	Limestone
Total Area	540 m ²
Wall Thickness	35-70 cm
Ground Floor Elements	1-Entrance 2- kitchen 3- Living Room 4- Bathroom 5- 2 Bedrooms 6 - Iwans 7- Balconies 8- Side Courtyard
First Floor Elements	1- Living Room 2- Bathroom 3- 3 Bedrooms

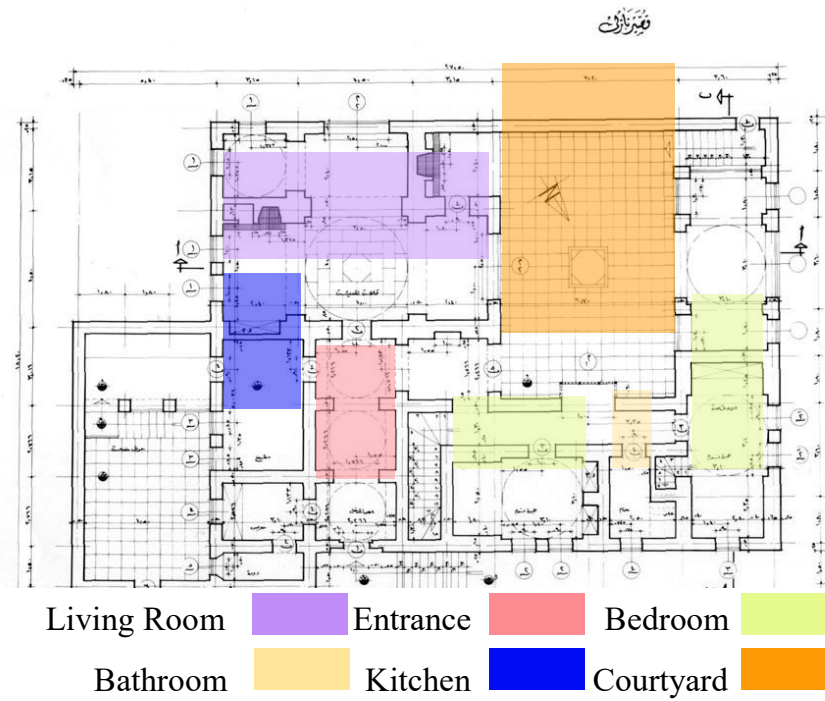

Fig. 6: The ground floor of Nazli Caseroni's palace.

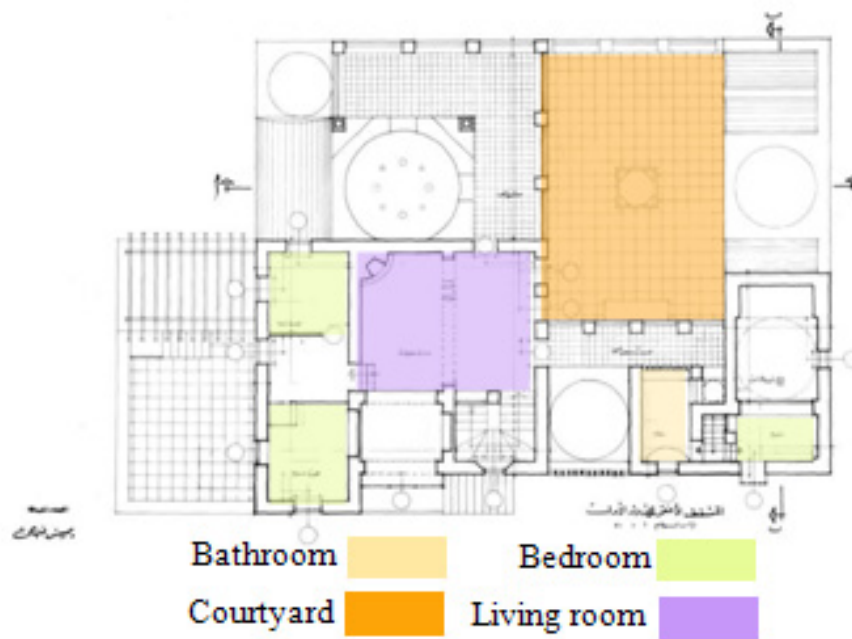

Fig. 7: The first floor of Nazli Caseroni's palace

Table 2: Ground floor's area and height details.

Nazli Caseroni's Palace	Total area (171) m ²	The Area of Spaces (m ²)	Wall thickness (cm)	The height of the dome (cm)
Entrance		13	35-50	100
Kitchen		10	40	-
Living Room		40	45-70	300
Bedroom1		18	45-65	120
Bedroom2		14	45-65	120
Bathroom		6	50-60	-
Side Courtyard		70	40-50	-

Table 3: First floor's area and height details.

Nazli Caseroni's Palace	Total area (61.5) m	The Area of Spaces (m ²)	Wall thickness (cm)	The height of the dome (cm)
Living Room		30	45-50	-
Bedroom1		9	45	120
Bedroom2		11	45	-
Bedroom3		6	45	-
Bathroom		5.5	45	-
Bathroom		6	50-60	-

Table (2-3) show each floor's area and height details.



Fig. 8: a- The wall thickness.

b- The side courtyard.

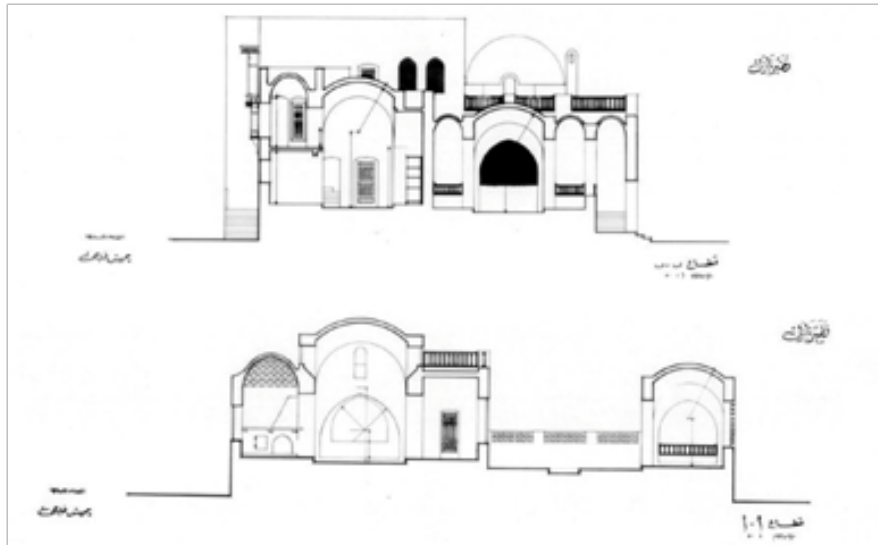

Fig. 9: Sections of the building.

III. Contemporary Residential Architecture:

Architects devote in order to create a new architectural trend, in which they provide their structures with volumetric green spaces; however, they intended to make visually illustrated green spaces. The author considers as if they borrow a piece of land from the ground floor and replaced it at the upper open space. They subtract an area of mass space, from their masses, to place new green spaces. The following example is selected to illustrate such new idea; such residential example is provided with green volumetric spaces. Architects of new trends as if want to provide the residents with an area of space form the green natural outdoor landscape to be close to them. However,

we only used to found green space at the ground floor level.

III.1. Residential tower, designed by (Meir Lobaton and Kristjan Donaldson):^[4]

Located in Mexico City, Mexico, the residential tower offers the family a luxury apartment house new living space, in which backyard comfort space at other places are missing.

The gardens spaces the architect placed at each level make an integration between the apartment house structure and the nature surrounding it. An attractive functional space for family members recreation been provided as shown by Figure 10.



Fig. 10: The tower and an illustration of the idea.

Figure 11 illustrates how each floor contains as a single apartment of 400 m² built up area with a garden extension of about 160 m². At the building typical floor level, a 90° rotation is made between floors; this is intended to create the apartment's green space. Gardens are placed above the bedroom spaces of the apartment below.

Levels horizontal shift intended to provide

enough space for full tree growth. The space created by this shift due to balance in between, the structure new green space and the nature surrounding it. The apartment interior living spaces placement took full advantage of the garden. However, such addition gives residences a sense of openness as presented by Figure 12.



Fig. 12: The view of the living rooms to achieve comfort.

IV. Analytical study – Author’s proposed Solutions:

The paper suggest the use of specially designed form of reinforced concrete slab on which the multi-story dwelling (1-3) floors could be easily placed. This proposal suggests Hassan Fathy units multiple repetitions vertically.

IV.1. The Paper 1st proposal:

IV.1.1. The first case: A 3 floors villa

Tables 4 + 5 + 6 represent each floor list of spaces, Figures 13 – 15 are the floor plans, Figure 16 is a cross section through the apartment house a ground floor, the first floor and the basement, illustrated by figures from 13 to 16. Figure 17 intended to illustrate how the apartment house is going to look like.

Table 4:1st proposal entrance floor space content

3 Floors 655 m ² Residential villa Design - Ground floor (Entrance floor) spaces list of content		
Space Utility	Area m ²	Space Height (m)
Entrance	10	3
Kitchen	22	3
Living room	58	3 – 3.7
An inner courtyard	89	11.25
Bedroom	23	3
Guest room	33	3 – 3.8
Office	21	3 – 3.8
Sitting room	23	3 – 3.8
Dining room	21	3 – 3.7
Morocco style -room	30	3 – 3.7

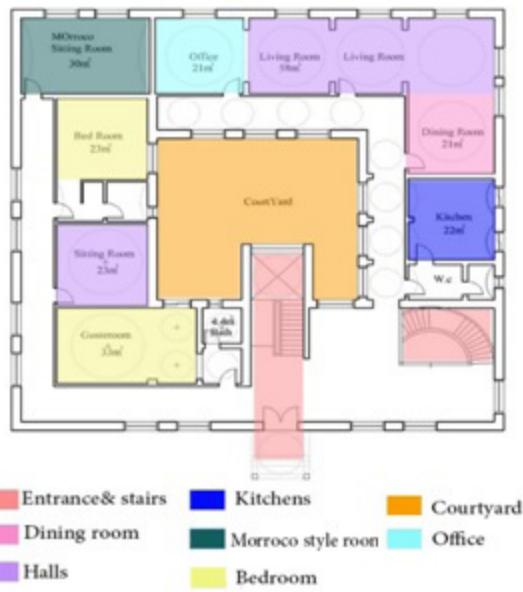

Fig. 13: 1st proposal ground floor plan of the (Entrance floor)



Fig. 14: The 1st floor plan.

Table 5: 1st proposal 1st floor space content

Space Utility	Area m ²	Space Height (m)
Entrance and Stair	80	3
Bedroom 1	34	3 – 3.8
Bedroom 2	33	3 – 3.8
Bedroom 3	40	3 – 3.8
An inner courtyard	89	11.25
Bedroom 4	36	3
Master Bedroom	49	3 – 3.8

Table 6: 1st proposal Entrance floor (-1) space content

Three-storey apartment proposal	Area details m ²	Height of the studied section (cm)
Entrance and Stair	130	300
Bedroom 1	35	300-377
Bedroom 2	33	300-377
An inner courtyard	89	1125
Billiard room	43	300
Gymnasium room	55	300
Living room	77	300-390



Fig. 15: Entrance floor (-1) plan.



Fig. 16: Section BB.

IV.1.2. 2nd case: A 3 floor villa

Figure 17 shows an alternation for villas placement according to each other. This alternation provides green open space accessible from the entrance floor.



Fig. 17: 3D shot illustrate Villas vertical distribution

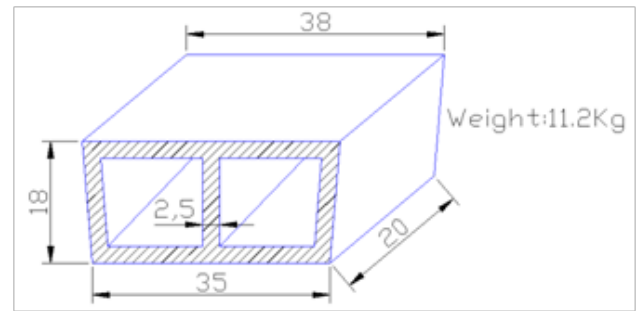

Fig. 19: The shape and dimensions of the Hurdy block.

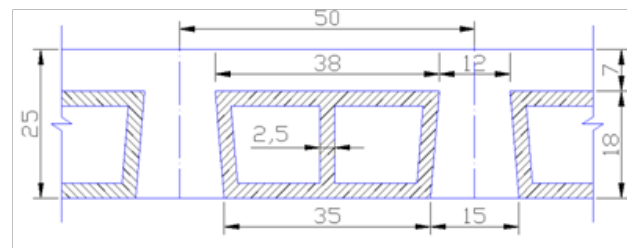

Fig. 20: Cross section of the Hurdy slab.

V. 1st proposal structural analysis:

Material resistance proposed: $f_c=25\text{N/mm}^2$ - $F_y=400\text{N/mm}^2$

1st proposal (Appendix B):

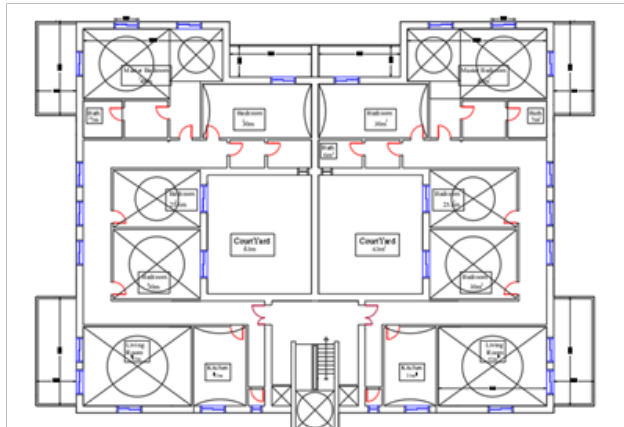

Fig. 18: Entrance floor Structure details.

The C columns dimension is: (0.9 * 0.5) m

The paper propose the use of Hollow Block (Hurdy) reinforced concrete slab form, one direction, as the main floor slab, 25 cm thick, can be adopted, which was obtained from the arrow condition according to the studied nerve models.

Internal main beams are designed as hidden beams dimensions B (60*25)

B-Dimensional Perimeter Main beam (60*25)

Broad Waffles b (40 * 25).

The following figure shows the shape and dimensions of the hollow block used, and an illustrative cross-section of the hurdy and nerve block.

The Waffle slab were distributed as follows:

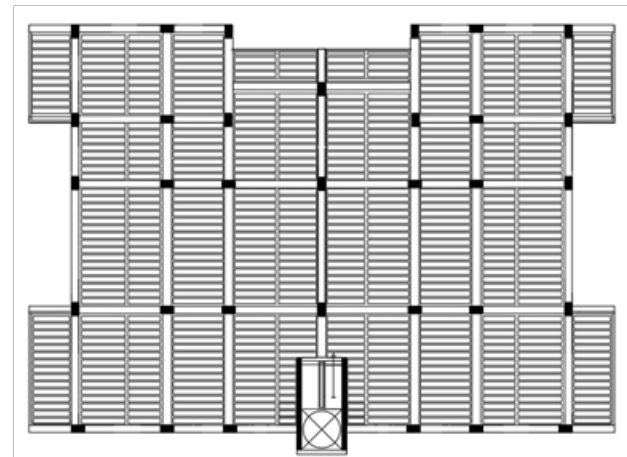

Fig. 21: The Waffle slab design.

The waffle slab in the green area adjacent to the opening of the building:

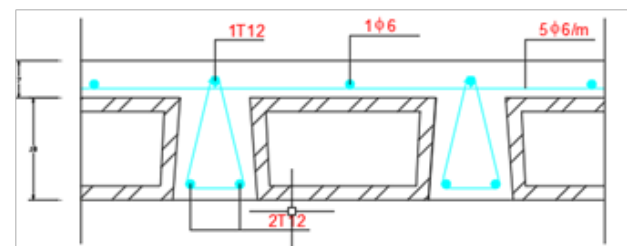

Fig. 22: The waffle slab section.

The waffle slab that holds the building is as follows:

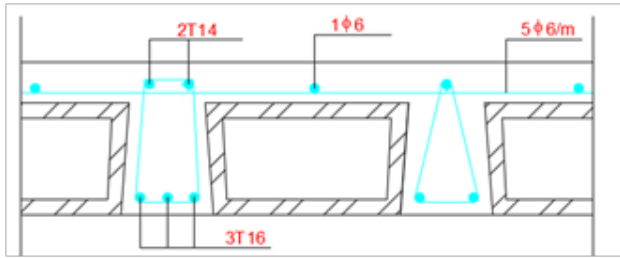

Fig. 23: The waffle slab that holds the building section.

For the First and Third case:

Considering the need for a relatively large floor height, the design will be made using a flat slab based at its edges on beams of 70 cm depth and columns with ring beam and column head, according to the construction need.

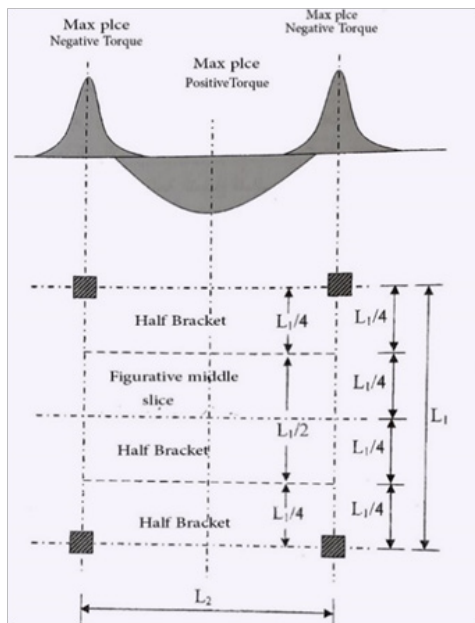

Fig. 24: Loads study details.

Depending on the requirements for a flat slab, the dimensions of the columns C (70 * 70) cm in the second case and C (90 * 90) cm in the third case can adopt.

The thickness of the slab is equal to 25 cm the fungal tiles are supposed to be divided into intermediate (figurative) and abutment segments.

The slab torques calculated according to the first approximate method:

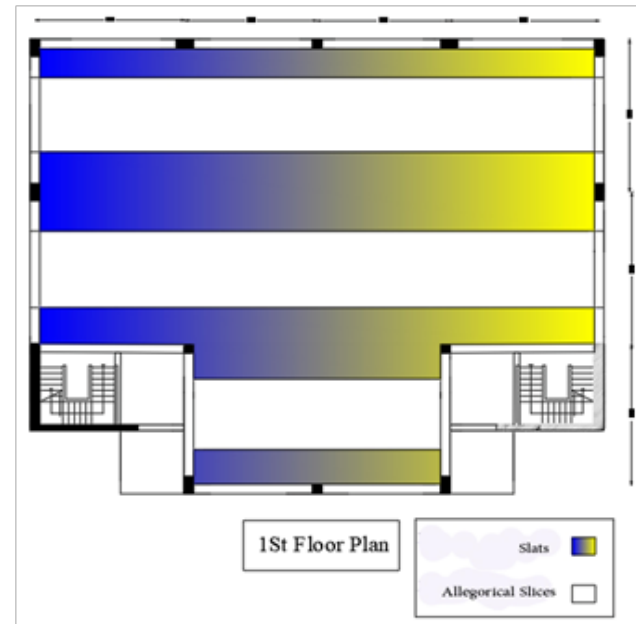

Fig. 25: First floor slab details.

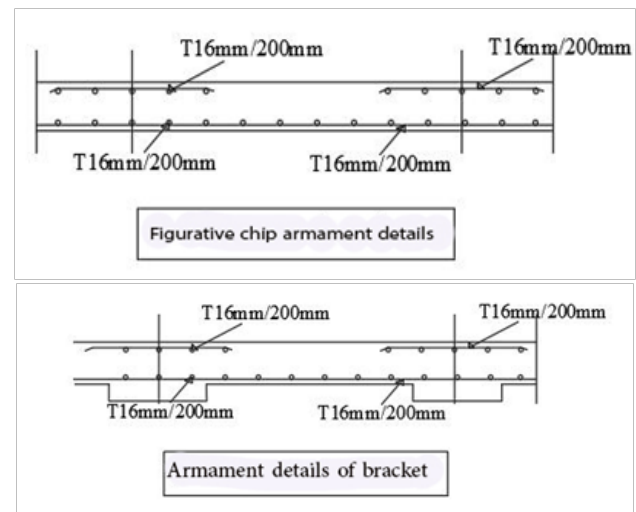
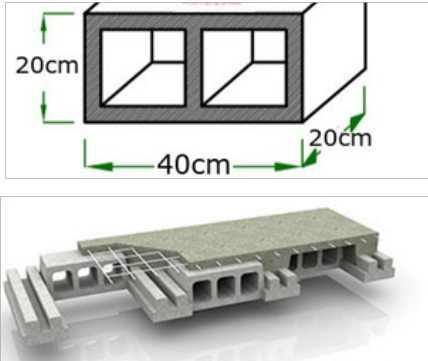

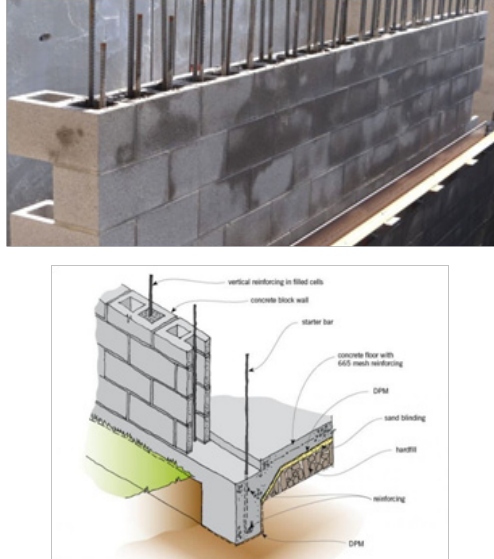

Fig. 26: a- slab section (figurative chip armament details).

b- Slab section (bracket armament details).
VI. Proposed architectural treatments for walls, flat - ceilings, vaults and domes:

The following table discuss materials and systems of proposals that can be applied in of multi-story buildings construction.

Table 7: Material Proposal in order to have both good environment and economic impacts

Element	Material	Definition and Description	Pictures
Ceilings	Hollow block slabs	<p>Hollow blocks slab system provides a void area larger than 25%, it is an example, masonry units made with sand and lightweight ash aggregates when used in the construction would add more Benefits: [5]</p> <ul style="list-style-type: none"> - Environmentally friendly, Lightweight and easy in construction. - Reduce Cost, Great insulation properties. - Highly durable, Bonding of mortar and plaster. 	
Vaults	GRC Article	<p>GRC - Glass reinforced cement, as a light weight composite material could be used in vaults and domes^[8]</p>	
Vaults	Paper Panels	<p>Economically, paper tubes made of partially recycled paper could be used as roof cover for low-cost housing systems purposes.^[6]</p>	
Walls	Hollow Concrete Block	<ul style="list-style-type: none"> - Hollow core concrete blocks, could be used as load bearing walls, if one placed vertical reinforcement bars (bar length should be equivalent with wall total height). - The Hollow core block provides good thermal insulation. - It has economic benefits - The external walls need applied veneers as finishing material.^[7] 	

6.1. Vaults and domes hidden within 2 slabs depth:

In the analytical study, three basic proposals will be studied to benefit from the aforementioned theoretical study, and each proposal differs from the other in its area and housing requirements, but they all placing the inner courtyard and to ensure privacy

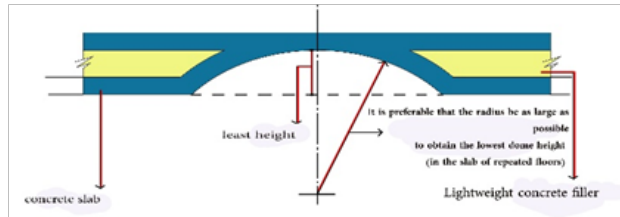

Fig. 27: Section, shows how vaults and domes could be hidden within the depth of 2 slabs.

VII. Conclusions:

- Indoor courtyard is an important design element of for its thermal effects at the house; it is adaptable with green architecture requirements what provides residents with a comfortable environment.

- Hassan Fathy's architecture could be applied in modern ' buildings, for its interactions with green architecture,

- Hassan Fathy's architecture is not limited to be applied at deserts or open countryside places

VIII. References:

- [1] Steele, James, "Architecture for people, The whole works of Hassan Fathy", A chapter references in edited book ,p107, 2008.
- [2] Fathi, Hassan, "Architecture for poor people", translated by Dr.Mostafa Ibrahim Fahmi, 1969.
- Websites:
- [3] Nazli Caseroni's Palace, website, <https://www.facebook.com/groups/ARCH.EGY/permalink/1542105479464144/>(acceded 2 September 2021).
- [4] Residential Tower - Meir Lobaton + Krišljan Donaldson, website, <https://www.archdaily.com/24924/residential-tower-meir-lobaton-krišljan-donaldson> (acceded 20 September 2020).
- [5] What are the benefits of hollow blocks in a slab? Website, <https://www.royalconcreteslabs.co.za/2020/12/02/what-are-the-benefits-of-hollow-blocks-in-a-slab/> (acceded 13 November 2021).
- [6] Paper Tower by Shigeru Ban. Website, <https://www.dezeen.com/2009/09/20/paper-tower-by-shigeru-ban/> (acceded 13 November 2021).
- [7] Minimization of heat ingress using insulated Hollow Concrete Block wall in buildings. Website, <https://www.nbmcw.com/product-technology/precast/minimization-of-heat-ingress-using-insulated-hollow-concrete-block-wall-in-buildings.html> (acceded 13 November 2021).
- [8] GRC, website, http://engislamelagouz.blogspot.com/2016/10/blog-post_2.html (acceded 5 March 2020).
- [9] Mohamed H. Ahmed, The identity crisis of contemporary architecture in the Egyptian city - With a focus on the identity of contemporary architecture in Assiut City as an example, website, https://www.kau.edu.sa/Files/0053569/Researches/24737_ازمة%20هوية%20عمارة%20المصرية. DOC (acceded 10 November 2020).
- [10] Fathy, Hassan, 1976, "TV interview on Autograph with Tariq Habib", Egypt TV.

Appendix A: Nazli Caseroni Palace details



Palace Façade



Side Courtyard and Iwans.



Palace Prospective.



The Side Courtyard.

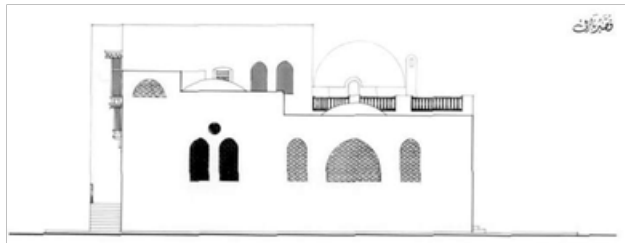

Palace Façade.



Roof and Balconies View.

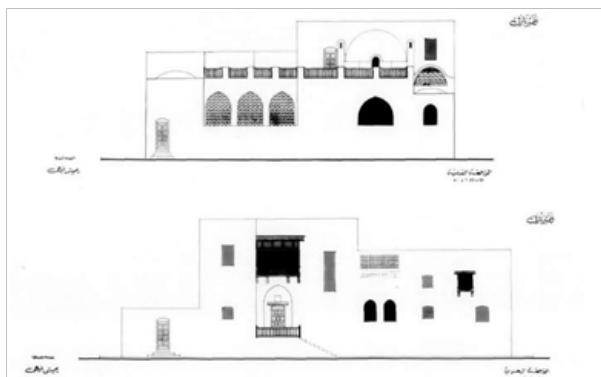

Palace Façades.



Living Room's Dome Design.



Entrance Design - Mashrabiah Design.



Interior Design Details.



Living Room Design.

Appendix B: Second suggestion

First case: We have a typical floor plan consisting of two symmetrical apartments.

Table a: First suggestion's elements, Area details

A residential building consisting of two symmetrical apartments on each floor, with an area of 1026 m², and the area of each apartment is 513 m².

One -storey apartment proposal	Area details m ²	Height of the studied section (cm)
Entrance	10	325-400
Kitchen	21	325-400
Living room	43	325-400
An inner courtyard	63	325
Bedroom1	30	325-400
Bedroom2	25	325-400
Main Bedroom	48	325-400
Bathroom	7	325-380
Dining room	30	325-400



Typical floor Plan

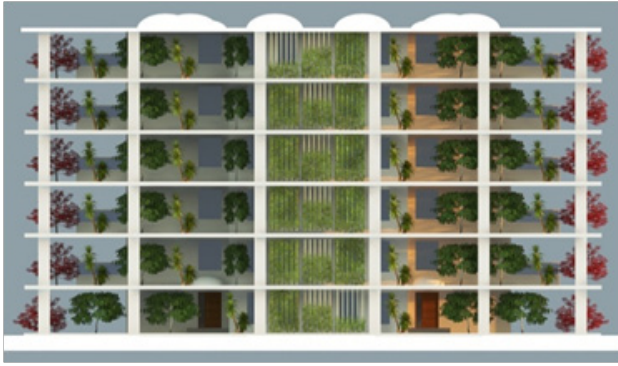

Shows the Facade of the building



The second case, one flat each level.

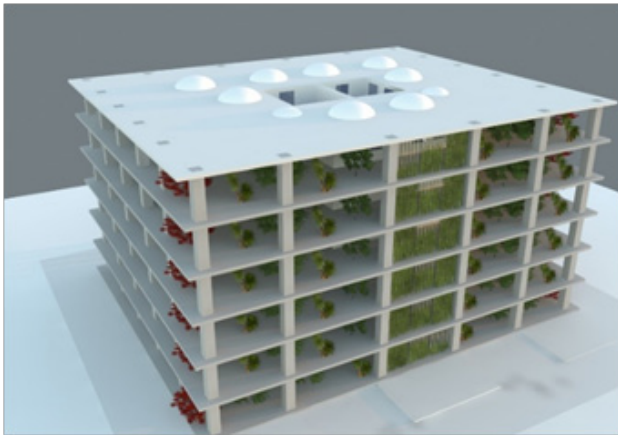

The placement of the building.

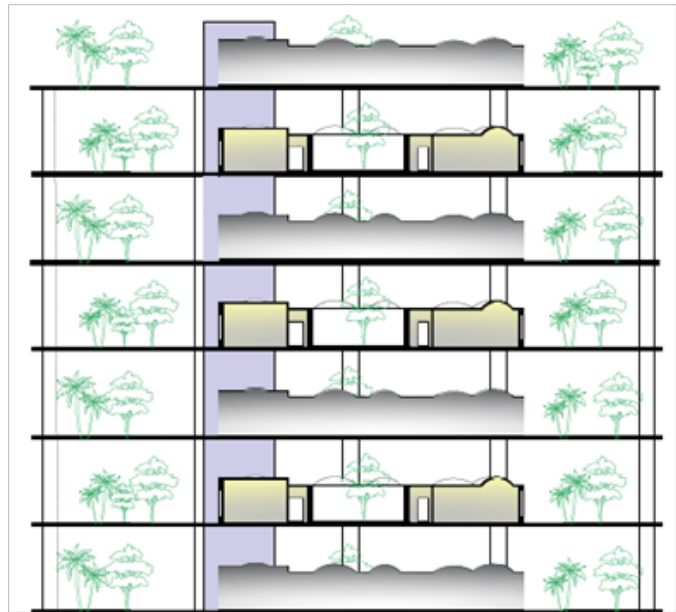

Section BB.



First case prospective.

The symmetrical section of the slab exploited in the form of an external roof garden in line with the modern formations of greenarchitecture.

The second case: the floor consists of one apartment with an external roof garden, and the apartment is repeated on the next floor in the opposite direction alternately.

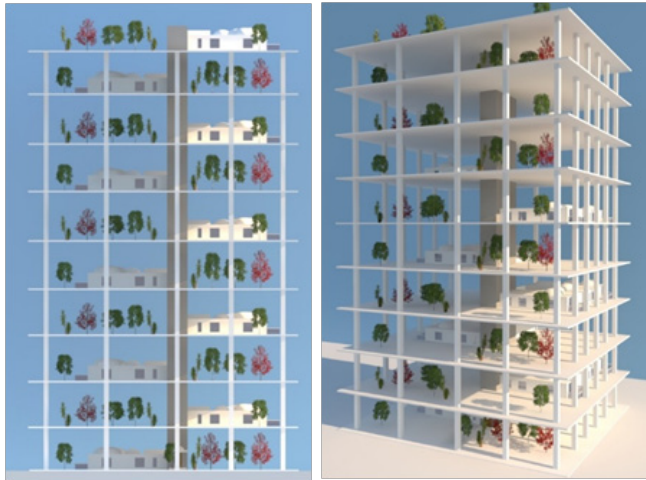

Second case façade - Second case perspective.



Second case perspective.

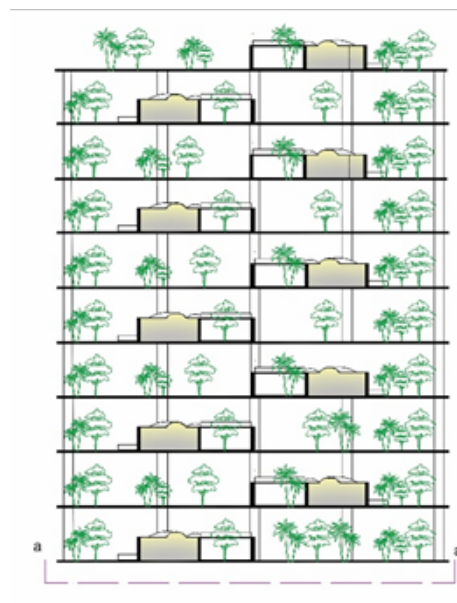

Second case section A.

Appendix C: Third suggestion

First case: The apartments are symmetrical, and one apartment is a duplex consisting of two floors, one floor with an area of 328 square meters. Ten floors, the floor area is 656 m², and it consists of two apartments.

Table b: Third suggestion's Ground floor details.

Two-storey proposal	apartment	Area details m ²	Height of the studied section (cm)
Entrance and Stair		30	300-390
Kitchen		32	300-380
Living room		78	300-380
An inner courtyard		47	705
Guest room		28	300-375
Dining room		27	300-380



Ground floor plan.

Table c: Third suggestion's first floor details.

Two-storey proposal	apartment	Area details m ²	Height of the studied section (cm)
Bedroom 1		47	300-390
Bedroom 2		27	300-380
Bedroom 3		32	300-380
Bedroom 4		28	300-390
An inner courtyard		47	705
Dining room		27	300-380



First floor plan.

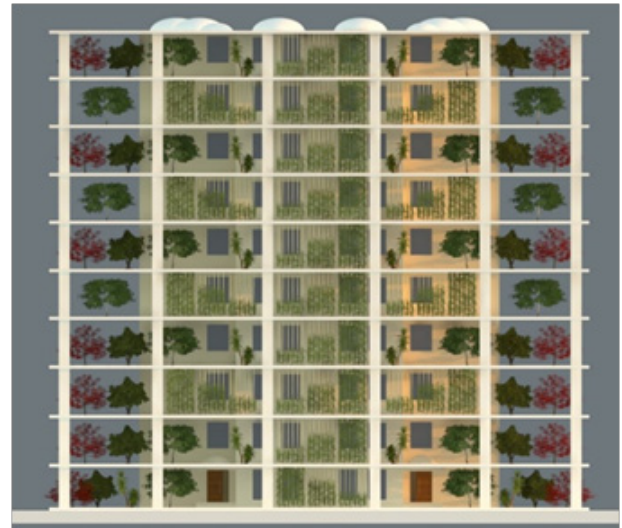

First case Facade.

The second case: The floor consists of one duplex apartment with an external roof garden, and the apartment is repeated on the next floor alternately in the opposite direction.



Section BB.



Ground floor Plan

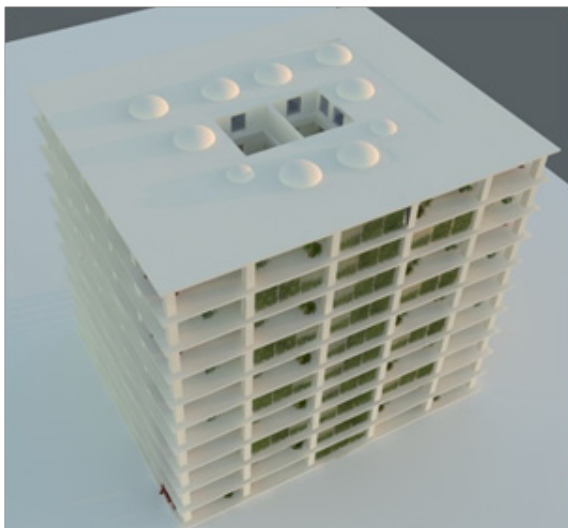

First case prospective.



First floor plan.



Section AA - Section BB.



Second case perspective.



Roof garden screenshot.

Appendix D: First suggestion details

– First case details:



Mass Perspective - Facade design.



Ground floor plan.



First floor plan.



Basement plan.

– Second case details:



Mass perspective.



Façade Design.

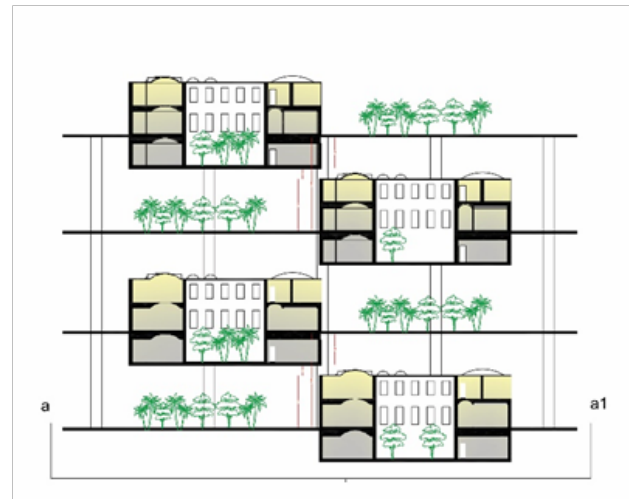

Section A.

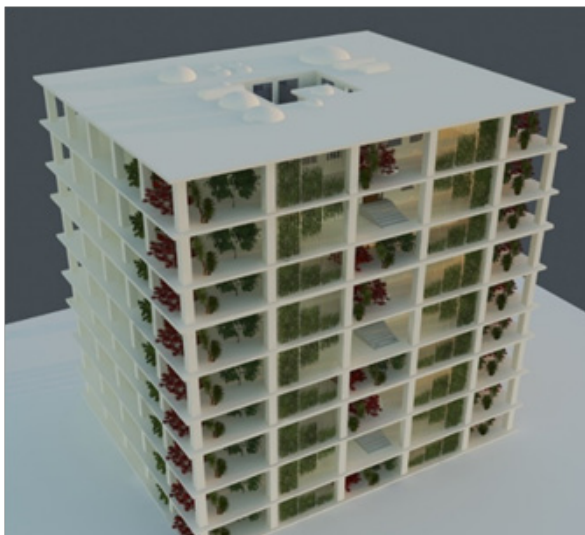

First case perspective.

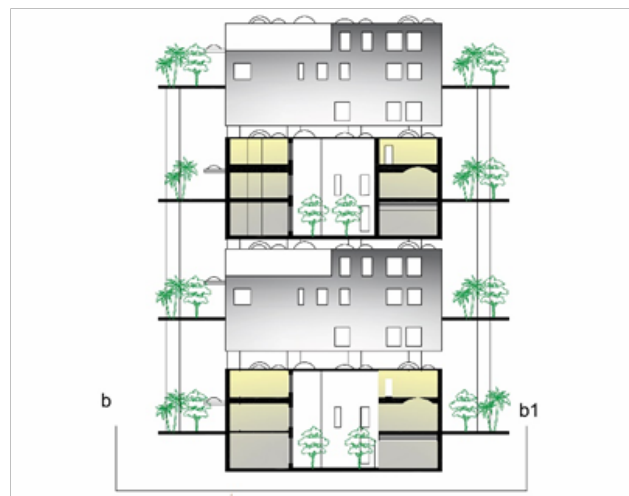

Section B.