

# Combination of SVC with PV-Inverter for Voltage Regulation in Distribution Networks

**Mahmoud M. Hussein**

Electrical Engineering Department  
Faculty of Energy Engineering, Aswan University  
Aswan, Egypt  
mahmoud\_hussein@aswu.edu.eg

**Ahmed M. Ewais**

Electrical Engineering Department  
Faculty of Energy Engineering, Aswan University  
Aswan, Egypt  
ewaisa@aswu.edu.eg

**Abstract**— in this paper, the static var compensator (SVC) combined with photovoltaic (PV) inverter system is suggested for completely solve the voltages deviations in distribution networks as a simplest method. The PV-inverter is playing a significant part in this voltage regulation control method. The SVC is integrated with the PV-inverter for permitting extra reactive power source. Therefore, they can successfully avoid voltage drop/rise produced by the loading and the intermittent PV generation system. A cooperative control technique can manage the reactive power capabilities of the PV-inverter and SVC. The 12.66 kV IEEE 33-bus distribution network is exploited to confirm the efficiency of the suggested integrated system. A certain complete day (24-hours) simulation is accomplished considering a variation of PV generation and presence different types of loads (domestic, industrial, commercial, and light). The results of simulation validate that the integrated control system succeeds in entirely eliminating the voltage deviations troubles with great PV penetration.

**Keywords**— *Distribution networks; photovoltaic (PV); static VAR compensator (SVC); voltage deviations.*

## I. INTRODUCTION

Reliance on the traditional energy resources, like oil, gas and steam for electrical generation, has negative environmental and economic impacts. Regard to the environmental viewpoint; the traditional energy sources are not friendly to the environment, and aid to discharge greenhouse gas emissions to the air. Also, regard to the economic viewpoint; the construction and the operating expenses of these traditional energy resources are comparatively great. Consequently, almost all countries exploit renewable energy resources, like photovoltaic (PV), wind, and hydraulic, and etc. for electrical generation. PV energy resource type is deemed one of the dissolute rising renewable energy resources all over the worldwide. Numerous countries have been advised to development the electrical generation by PV energy resource and also to connect this type of energy into the utility network in the following coming years [1]–[3].

PV energy is a vastly discontinuous energy resource. Therefore, this unusual attitude of power generation leads to numerous challenges for the process and control the overall energy system. Where, the delivered real power from PV system into the grid leads to increase a local voltage as a result of increasing of PV bus voltage. For numerous cases, the bus

voltage is greater than the higher boundary of acceptable voltage, thus it leads to the utility voltage regulating component to operate (for example, line regulators and capacitors) with fluctuated PV system power generation [4], [5].

With great penetration of PV generation system in distribution system, power generation of PV system is predictable not only to danger voltage deviations by substation transformers tap changers but additionally supply opposite power flow problems in the system. With great installation of PV energy systems through many customers, a problem of over voltage is appeared in the distribution networks [6]–[8]. Abundant exertions have been prepared for eliminating the over voltage deviation that caused by the addition of fluctuated PV power generations. D-STATCOM with PV-inverter have been utilized as a compensation of reactive power at the joining bus to solve voltage deviations problems [9]. Management supplying of reactive power for the distribution network can be accomplished utilizing on load tap changing transformers (OLTCs) [10], [11]. Furthermore, There are a lot of methods in the distribution systems for absorption reactive power [12], [13].

Adaptable the distribution system voltages inside the definite acceptable boundaries are a crucial accountability for utility companies to reserve the power readability of the system. Techniques of switched devices like on load tap changers (OLTCs), shunt capacitor banks (SCBs), and voltage regulators could be exploited to control the conventionally profile of system voltage and flow of reactive power in distribution system. Unfortunately, these types of devices are switched rare times during a day to conform reasonably sluggish variants in the system load. Thus, these types of techniques are not appropriate for eliminating the more rapid variations problem associated with PV power generation system. Therefore, inverters could be exploited to suck or deliver reactive power in addition to deliver active power into the distribution network. Nevertheless, agreeing with IEEE 1547, the current standard for incorporation of distributed energy resources, inverters can't intensely contribute to control the voltage/var. This restriction must be completed with small penetration of PV generation, nonetheless with greater PV penetration, inverters is essential to contribute for voltage/var regulation [4].

In this manuscript, a combination of SVC with PV-inverter is suggested to regulate the voltage for the IEEE 33-bus distribution networks, where the PV-inverter is playing a significant part in this voltage regulation control method. At night, the voltage becomes lesser than the definite voltage boundary agreeing with no PV power generation, in this case, the inverter can support enough quantity of reactive power agreeing with rated apparent power of the inverter to increase the level of output voltage and insure it becomes inside the definite voltage boundaries. Nevertheless, at the day time, the PV system deliveries power into the distribution network, and also at the identical period, the voltage is greater than the higher boundary of voltage. In this case, the inverter could suck reactive power according to its rated power that cannot permit it to suck satisfactory amount of reactive power to decrease the voltage and insure it becomes inside the definite voltage boundaries. The part of SVC is seemed in this case to suck the reactive power utilizing switched inductors for decreasing the output voltage and insure it becomes inside the definite voltage boundaries.

## II. PV-INVERTER FOR VOLTAGE CONTROL

The presence of PV energy system with great penetration in the distribution network has undesirable influences on the voltage profiles. Therefore, regulating the voltage in low/medium distribution networks is a significant matter as it is the accountability of distribution networks workers to preserve the voltage inside the permissible voltage boundaries. PV system involves of PV arrays and an inverter that connects the PV array to the distribution network.

The maximum generated active and reactive powers of PV system at any instant can be stated as the following:

$$P_{PV,i}(t) = P_{MPP,i}(t) \quad (1)$$

$$Q_{PV,i}^{max}(t) = \sqrt{S_r^2(t) - P_{MPP,i}^2(t)} \quad (2)$$

where  $P_{MPP,i}$  is the greatest allowable power can be extracted from the PV energy system with ambient radiation and temperature conditions [14]. It is significant to reminder that with great PV power penetration in the distribution network, the delivered active power into the distribution system leads to presence a rise in local voltage. Occasionally this increase in local voltage is great that may cause opposing voltage oscillations for other load buses. The PV power generation and its inverter spare capacity can be presented in Fig. 1. The PV-inverter spare capacity can be stated as the following equation.

$$S_{sp,i}(t) = S_{r,i}(t) - S_i(t) \quad (3)$$

Fig. 2 indicates the PV inverter capability. Whereas after Sun set, the PV system can't supply power into the distribution, therefore the PV-inverter can be a source of maximum amount

of reactive power according to (3). The PV inverter could deliver sufficient reactive power into the system for increasing the bus voltages and make it greater than the lower boundary of the permissible voltage. During a day time, the PV arrays already delivers active power to the distribution network and also the voltage is greater than the higher boundary of the permissible voltage, in this case the inverter must suck reactive power from the distribution system to decrease the voltage under the higher boundary of the permissible voltage, whilst the rating of PV-inverter limits the sucked amount of reactive power in accordance with (2). It is significant to reminder that the PV-inverter spare capacity is almost zero with maximum generation of PV energy system when the PV-inverter rating equals the maximum generation of PV energy system. Consequently, the PV-inverter cannot support for solving the problem of voltage rise in this case, particularly with great PV penetration.

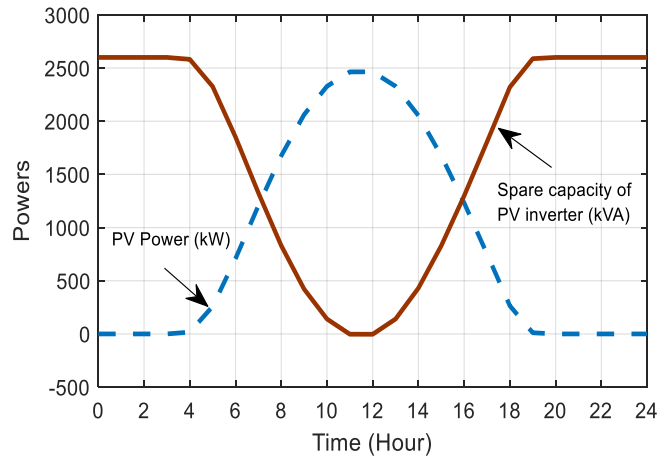

Fig. 1. PV power generation and its inverter spare capacity

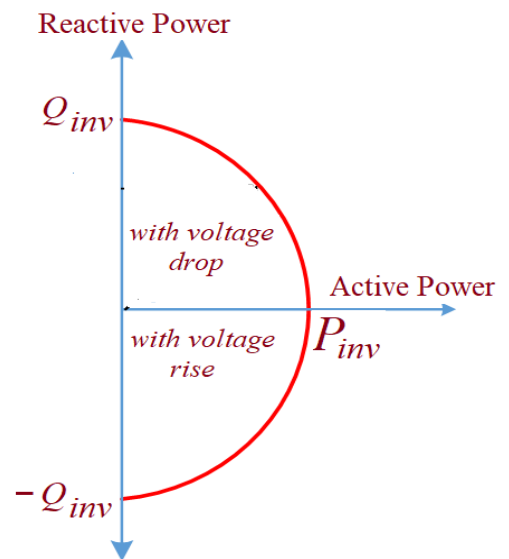

Fig. 2. PV-inverter Capability curve.

### III. PV-INVERTER WITH SVC FOR VOLTAGE CONTROL

A combination of PV-inverter with SVC is proposed in this section for regulating the voltage of the distribution networks with great penetration of PV generation. The connection of PV-inverter with SVC in a distribution network at bus ( $k$ ) is shown in Fig. 3. A bank of SVC is linked in parallel with the PV-inverter for regulating the voltage of the distribution network.

$$P_k = P_{PV,k} - P_{D,k} \quad (4)$$

$$Q_k = Q_{PV,k} + Q_{SVC,k} - Q_{D,k} \quad (5)$$

in which

$$Q_{PV,k}(t) = \begin{cases} + & V_k < V_k^{\min} \\ - & V_k > V_k^{\max} \\ 0 & V_k^{\min} \leq V_k \leq V_k^{\max} \end{cases} \quad (6)$$

$$Q_{SVC,k}(t) = Q_{SVC,k}(t-1) + QM_t \quad (7)$$

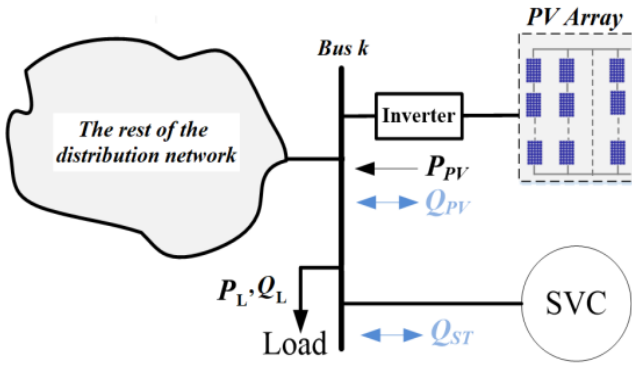

Fig. 3. Combined of PV-inverter with SVC in a Distribution network.

$$QM_t = \begin{cases} +Q_{step} & V_k < V_k^{\min} \\ -Q_{step} & V_k > V_k^{\max} \\ 0 & V_k^{\min} \leq V_k \leq V_k^{\max} \end{cases} \quad (8)$$

Equations (6) and (7) are utilized for controlling the delivered reactive power by the PV-inverter and SCV to adjust the

distribution network voltage. In case of voltage deviations occasions, the PV-inverter will suck/deliver reactive power with bearing in mind its rating, as demonstrated in (2). After using the available reactive power of PV-inverter, if the voltage is still deviated, the permissible voltage boundary, SVC will be functioned to governor the voltage. The SVC is capable of minimizing the voltage deviation and adjusts the reactive power in the distribution network. It could deliver the reactive or capacitive current into the distribution network at the connected bus. It is capable of delivering reactive power very quickly to adjust the voltage in distribution networks. Also, SVC has capability to interchange its capacitive or inductive output current for solving the problem of voltage deviations. SVC controls the voltage by adjusting the value of reactive power delivered/sucked to/from the distribution network in accordance with (8). It supplies reactive power using capacitor banks once the bus voltage is smaller than the down boundary of the permissible voltage. Similarly, SVC sucks reactive power using inductor banks when the system voltage is greater than the higher boundary of the permissible voltage. In this manuscript, the backward/forward sweep power flow method is utilized to compute the steady-state voltages with the variation of loads and PV generation [15].

### IV. RESULTS AND DISCUSSIONS

#### A. Tested system

To prove the success of the suggested control system, the 12.66 kV IEEE 33-bus distribution network (Fig. 4) is tested throughout a certain day (24 hours). The overall reactive and active powers of the loads are 2.290 Mvar and 3.715 MW, respectively. The comprehensive information is specified in [16]. It is assumed that the buses of the distribution network have different types of loads (domestic, industrial, commercial, and light) as illustrated in Table I. The load profile for each type of load can be shown in Fig. 5. The PV array and the SVC bank are presumed to have linked at bus 18. The rated capacity of the utilized PV module is 450 Watt. Its chief characteristics are indicated in Table II. The PV modules are collected as 90 branches in parallel and each branch has 60 PV modules in series. Consequently, the overall maximum power allowable is about 2.430 MW (great penetration). As it is known, the extracted PV array power increases with increasing the radiation and decreasing the surrounding temperature. The rating of the inverter that connects the PV arrays with the distribution network should be more than the maximum extracted power from the PV arrays for supplying reactive power in case of extracting maximum active power. Therefore the rating of the PV-inverter must be at least 2.6 MVA.

TABLE I. DISTRIBUTION OF TYPES OF LOADS ON THE DISTRIBUTION NETWORK

Types of loads	Connected bus
Domestic	2-6, 26-29
Industrial	7-13, 30-33
Commercial	18-22
Light	14-17, 23-25

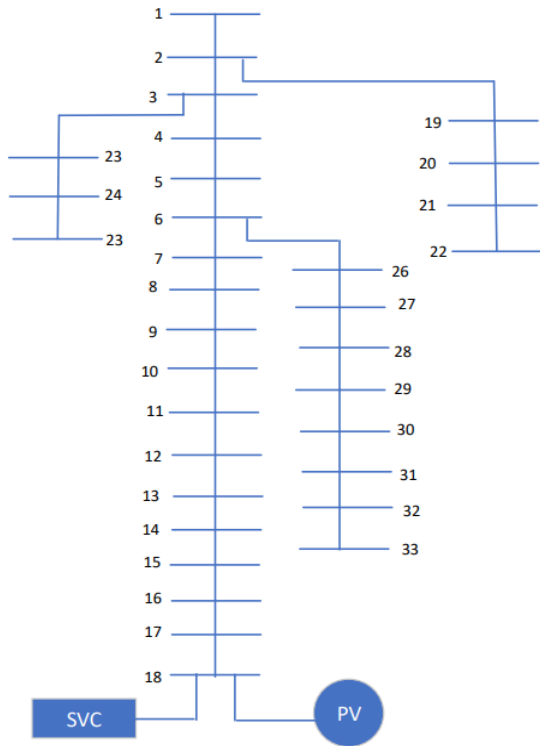

Fig. 4. IEEE 33-bus modified distribution network.

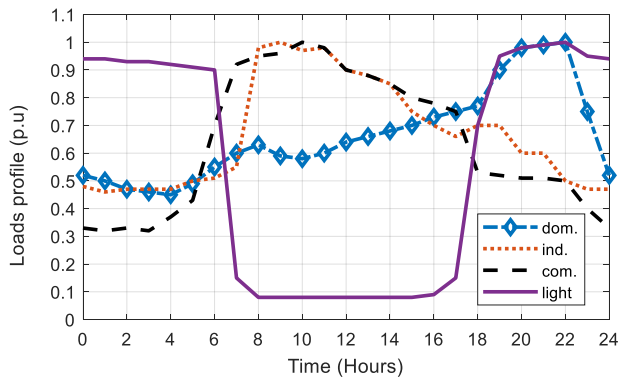

Fig. 5. Loads profile (p.u) throughout a day.

TABLE II. PV MODULE ELECTRICAL CHARACTERISTICS AT 25°C TEMPERATURE AND 1000 W/M<sup>2</sup> IRRADIANCE LEVEL

Symbol	Quantity	Value
$P_{MP}$	Maximum Power	450 W
$V_{MP}$	Voltage at $P_{MP}$	41,5 V
$I_{MP}$	Current at $P_{MP}$	10.85 A
$I_{SC}$	Current of short circuit	11.6 A
$V_{OC}$	Voltage of open circuit	49.3 V
$T_{SC}$	Temperature coefficient of $I_{SC}$	0.0005 (A/K)
$T_{OC}$	Temperature coefficient of $V_{OC}$	-0.133(V/K)

### B. Studied scenarios

A day simulation is implemented for the IEEE 33-bus examined network. Fig. 6 displays the radiation and temperature through a certain day that relating to PV power profile displayed in Fig. 1. Different three scenarios are investigated in this manuscript, as the following:

- **Scenario 1:** The modified distribution network without any control.
- **Scenario 2:** The modified distribution network with PV-inverter control.
- **Scenario 3:** The modified distribution network with SVC bank and the PV-inverter control.

### C. Analysis

For the previous studied three scenarios throughout a day, Figs. 7 displays the voltage of the buses for the IEEE 33-bus distribution network related to scenario 1 which are greatly influenced by the PV power generation. It can be noticed that, the voltage deviates the upper boundary throughout most of the day time as a result of the great generation of the PV. Furthermore, the voltage of several buses deviates, the down boundary throughout the night period.

Fig. 8 illustrates the voltage profile related to scenario 2 throughout the day. Scenario 2 can be deemed an alternate method for eliminating the voltage deviation trouble in scenario 1. The PV-inverter in scenario 2 could support for solving the discontinuous PV active power generation via delivering reactive power in case of voltage drop and sucking reactive powers in case of voltage rise.

It is significant to observe the delivered reactive power via the inverter could eliminate the voltage decrease trouble throughout the night; nonetheless it can't totally eliminate the voltage increase trouble throughout the day period. This result of the spare capacity of the inverter is not enough, and consequently the permissible reactive power delivered is deficient to control the voltage, as observed in Fig. 9.

The profile of the system voltage for scenario 3 is presented in Fig.10. As shown, the voltage deviations problem throughout the day and night periods are totally eliminated. The delivered reactive power of SVC bank and the PV-inverter with SVC bank are displayed in Fig.11 and Fig.12, respectively. The SVC bank is significantly cooperative to eliminate the voltage rise trouble throughout a day period in case of completely loaded of the PV-inverter. It is conspicuous that the integrated of the SVC with the PV-inverter can significantly control the voltage in the distribution network.

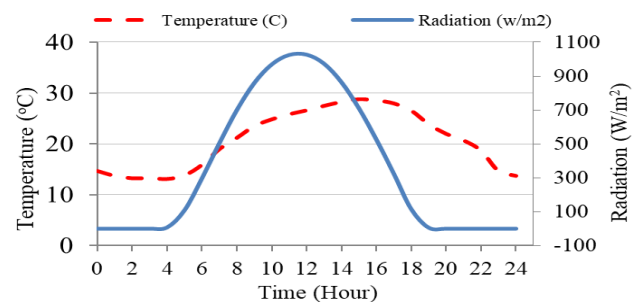

Fig. 6. Temperature and radiation throughout a certain day.

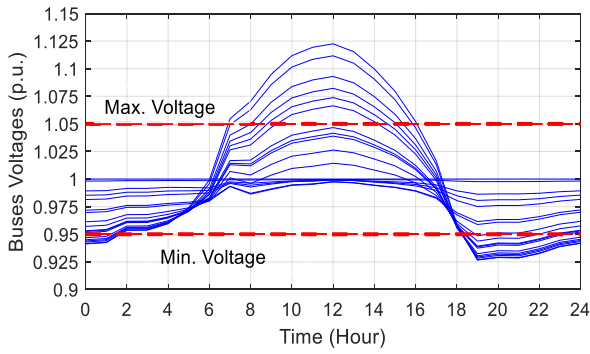

Fig. 7. Voltage profile of the system for scenario 1.

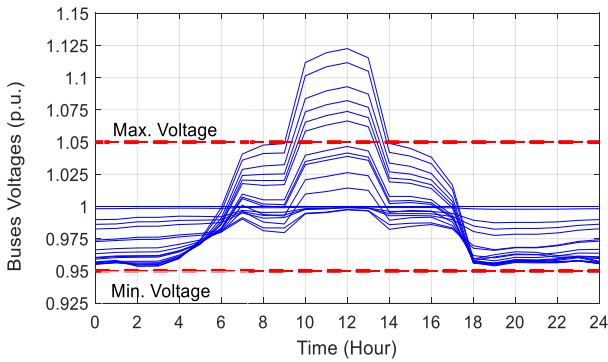

Fig. 8. Voltage profile of the system for scenario 2.

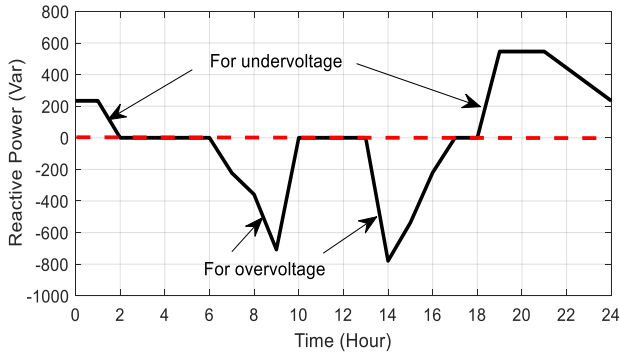

Fig. 9. Reactive power of PV-inverter throughout the day for scenario 2.

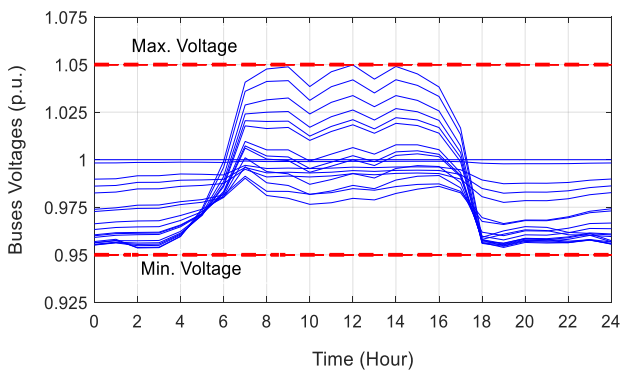

Fig. 10. Voltage profile of the system for scenario 3.

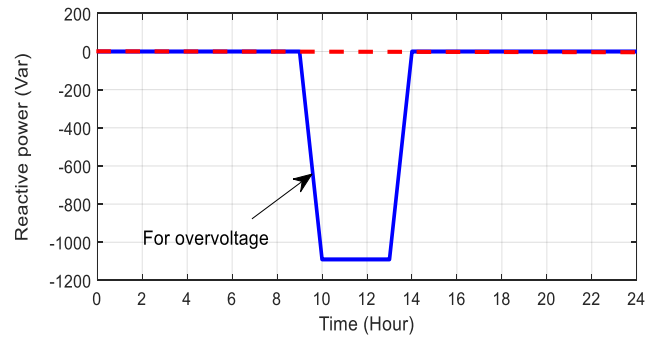

Fig. 11. Reactive power the bank of SVC throughout the day for scenario 3.

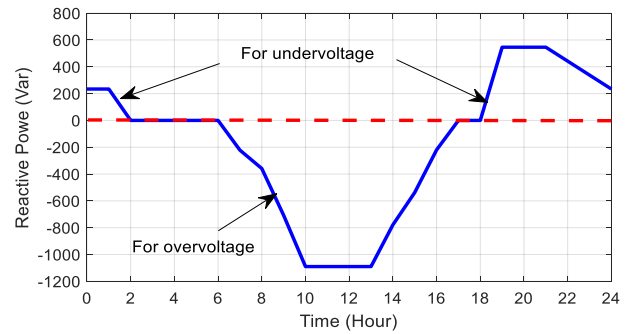

Fig. 12. Reactive power of the inverter with the SVC throughout the day for scenario 3.

## V. CONCLUSIONS

The worst effect of great PV penetration is the voltage deviations. In this manuscript, we have suggested an integrated of SVC with PV-inverter for entirely eliminating the voltage deviation trouble with great PV penetration in the network. The SVC bank is exploited to adjust the voltage when the PV-inverter is completely loaded. The integrated system (SVC bank and PV-inverter) alleviates the voltage increase/decrease by managing the reactive power of the system. The IEEE 33-bus distribution network is utilized to prove the efficiency of the suggested integrated system. The results exhibit that the integrated system can totally eliminate the voltage deviation troubles throughout the whole day with great PV penetration. The suggested control system of integrated SVC with PV-inverter is verified for eliminating the voltage deviation troubles.

## REFERENCES

- [1] Y. Chai, L. Guo, C. Wang, Z. Zhao, X. Du, and J. Pan, "Network Partition and Voltage Coordination Control for Distribution Networks With High Penetration of Distributed PV Units," *IEEE Trans. on Power Systems*, vol. 33, no. 3, pp. 3396 – 3407, May 2018.
- [2] D. Chaturangi, U. Jayatunga, M. Rathnayake, A. Wickramasinghe, A. Agalgaonkar, and S. Perera "Potential power quality impacts on LV distribution networks with high penetration levels of solar PV," *18th International Conference on Harmonics and Quality of Power (ICHQP)*, Ljubljana, Slovenia, 13-16 May 2018.
- [3] S. Mahdavi, H. Panamtaash, A. Dimitrovski, and Q. Zhou, "Predictive Coordinated and Cooperative Voltage Control for Systems With High Penetration of PV," *IEEE Trans. on Industry Applications*, vol. 57, no. 3, pp. 2212 – 2222, May-June 2021.

- [4] J. Liu, Y. Li, C. Rehtanz, Y. Cao, X. Qiao, G. Lin, Y. Song, and C. Sun, "An OLTC-inverter coordinated voltage regulation method for distribution network with high penetration of PV generations," *International Journal of Electrical Power & Energy Systems*, vol. 113, pp. 991-1001, Dec. 2019.
- [5] J. Payne, F. Gu, G. Razeghi, J. Brouwer, and S. Samuelsen, "Dynamics of high penetration photovoltaic systems in distribution circuits with legacy voltage regulation devices," *International Journal of Electrical Power & Energy Systems*, vol. 124, 106388, Jan. 2021.
- [6] T. Tewari, A. Mohapatra, and S. Anand, "Coordinated Control of OLTC and Energy Storage for Voltage Regulation in Distribution Network With High PV Penetration," *IEEE Trans. on Sustainable Energy*, vol. 12, no. 1, pp. 262 – 272, Jan. 2021.
- [7] M. Chamana, and B. H. Chowdhury, "Optimal Voltage Regulation of Distribution Networks With Cascaded Voltage Regulators in the Presence of High PV Penetration," *IEEE Transactions on Sustainable Energy*, vol. 9, no. 3, pp. 1427 – 1436, July 2018.
- [8] D. Almeida, J. Pasupuleti, J. Ekanayake, and E. Karunarathne, "Mitigation of overvoltage due to high penetration of solar photovoltaics using smart inverters volt/var control," *Indonesian Journal of Electrical Engineering and Computer Science*, vol. 19, no. 3, pp. 1259-1266, Sep. 2020.
- [9] K. Mahmoud, M. Abdel-Nasser, M. Lehtonen, and M. M. Hussein, "Optimal Voltage Regulation Scheme for PV-Rich Distribution Systems Interconnected with D-STATCOM," *Electric Power Components and Systems*, vol. 48, pp. 2130–2143, March 2021.
- [10] C. Li, V. R. Disfani, Z. K. Pecenak, S. Mohajeryami, and J. Kleissl, "Optimal OLTC voltage control scheme to enable high solar penetrations," *Electric Power Systems Research*, vol. 160, pp. 318-326, July 2018.
- [11] A. D. Pizzo, L. D. Noia, D. Lauria, M. Crispino, A. Cantiello, and F. Mottola, "Control of OLTC distribution transformer addressing voltage regulation and lifetime preservation," *International Symposium on Power Electronics, Electrical Drives, Automation and Motion (SPEEDAM)*, Amalfi, Italy, 20-22 June 2018.
- [12] A. Arshad and M. Lehtonen, "A Stochastic Assessment of PV Hosting Capacity Enhancement in Distribution Network Utilizing Voltage Support Techniques," *IEEE Access*, vol. 7, pp. 46461 – 46471, April 2019.
- [13] P. Chaudhary and M. Rizwan, "Voltage regulation mitigation techniques in distribution system with high PV penetration: A review," *Renewable and Sustainable Energy Reviews*, vol. 82, Part 3, pp. 3279-3287, Feb. 2018.
- [14] A. R. Jordehi, "Maximum power point tracking in photovoltaic (PV) systems: A review of different approaches," *Renew. Sustain. Energy Rev.*, vol. 65, pp.1127–1138, Nov. 2016.
- [15] N. Yorino and K. Mahmoud, "Robust quadratic-based BFS power flow method for multi-phase distribution systems," *IET Gener. Transm. Distrib.*, vol. 10, no. 9, pp. 2240–2250, Jun. 2016.
- [16] V. Vita, "Development of a Decision-Making Algorithm for the Optimum Size and Placement of Distributed Generation Units in Distribution Networks," *Energies*, vol. 10, no. 9, 1433, Sept. 2017.