



PV Parameters Monitoring using Portable and Wireless Data Acquisition System.

M. Kamal^{1,*}, M.A. Mohamad¹

¹Solar Energy Dept., Engineering and Renewable Energy Research Institute, National Research Centre, Cairo, Egypt

ARTICLE INFO

Article history:

Received:07-02-2022

Accepted:26-07-2022

Online: 26-07-2022

Keywords:

PV systems,

Data acquisition,

Microcontroller,

Wireless transceiver,

Weather parameters,

PLX-DAQ.

ABSTRACT

In this paper, we proposed the design and development of Portable Wireless Data Acquisition System (PWDAS) prototype for PV solar system with Real Time Clock (RTC). The wireless technology is very much easier to implement rather than wired system. Parameters like PV panel voltage, current and its surface temperature and the affected weather parameters using available and low cost sensors are considered. The designed PWDAS prototype is based on Arduino microcontroller boards, and NRF24L01 wireless transceiver modules. The aggregated data are presented in Excel using the PLX-DAQ data acquisition Excel Macro. The PLX-DAQ connects the Arduino control board and the computer by UART bus. From the result obtained throughout the test and experiments carried out, data sent from the weather station were successfully received at the test station PC and reported to the PLX-DAQ Excel Macro using serial monitor of Arduino IDE.

1. Introduction

Egypt has the potential to reach 44 GW of installed photovoltaic (PV) power by 2030, according to International Renewable Energy Agency IRENA, which has outlined how the Northern African country could develop its renewable energy strategy [1].

Using of this energy not only determines the way to use of these resources but also provide accurate evaluation to adjust resources in better way to overcome energy resource crisis. Data gathering helps us to follow situation of solar systems under the effects of different factors [2].

The characteristics of PV modules are very important to determine how efficient the solar module is, and therefore we could determine the efficiency of an array. The goal of this work is to build a portable PV analyzer controlled by a microcontroller for testing PV systems. MOSFET transistor will be utilized as a fast varying electronic load to draw I, P versus V curves. The portable analyzer will be used within either the department testing area or wherever any PV system should be tested and evaluated. The PV analyzer system consists of three

basic subsystems that are electronic load, Data Acquisition (DAS) and Wireless Weather Station subsystems (WWS).

Wireless technologies are predictable to support great benefits in terms of flexibility. They avoid long wires that are hard to place or may become an obstruction [3]. These benefits are noticeable when mobile subsystems are included in the control loop (e.g. actuators or sensors), but in general avoiding wires facilitates the construction and servicing of any system, and minimizes the expense [4]. In addition, some systems with harsh environment need to collect the multi-channel data volume of them in real time, but these places are often high-temperature environments, direct sunlight for long periods, or with conditions that are harsh. If the staff stays at the system location, they will be very large damage. Therefore, the staff should be kept a safe distance from the tough locations.

N. Mahzan et al [5] submitted a design of data acquisition system for monitoring the parameters of a 240-W PV system which utilizes Arduino Mega 2560 board. The system will convert the acquired data to digital input and will store the data onto micro SD card. Results are recorded and compared with the data that was taken by one commercial data acquisition system during the testing period. This is to test the data reliability as

* M. Kamal, Solar Energy Dept., National Research Centre, Cairo, Egypt, +201111055673, mohamad_kamal2010@hotmail.com

well as to examine the performance of the suggested data acquisition during the testing process.

B. Jiang et al [6] suggested the operation monitoring of a PV system which requires data loggers and web transfer together to gather the sensor data. The data includes the measurement of both the voltage and current of the PV system and the weather of that location. The weather station of the PV system in Memorial University of Newfoundland (MUN) is 5 m far from the window. The PV systems are approximately 25–50 m far from the weather station. Then it is more considerable to use wireless technique for connecting the sensors rather than long cables.

T. Singh et al [7] presented the design and development of two channel data logger which provide the cheap and feasible solution for monitoring and recording the voltage, current, power and energy of two PV solar panels. The designed prototype data logger is based on Arduino microcontroller board and recorded the data logging on SD card or on the memory of mobile phone using Bluetooth signal. Then they found that the final Remote monitoring and recording of data is possible with this data logger.

I. Calvo et al [8] evaluated the use of wireless technologies to be used in control applications when compared with wired technologies. They focus on an approach based on XBee and LabVIEW technologies. On one side, XBee is used for providing wireless communications among sensors, controller and actuators. XBee devices are characterized by its low power consumption.

H. Saha et al [9], compared and contrasted the efficiency and performance of NRF24L01+ against XBee modules. They analyzed Received Signal Strength Indicator (RSSI), network throughput, packet delay, mesh routing, recovery time and energy consumption parameters. They found in the study that, NRF24L01+ could provide a better throughput compared to XBee in almost all scenarios especially in point-to-point communication. For multihop networks as well, the rate of transmission remains considerably higher.

In this paper we proposed the design and development of PWDAS prototype that will offer a seamless and cost-effective solution to the problem of gathering remote sensory data instead of wired connection and their known troubles. In the next paper a complete PV analyzer, included PWDAS as a subsystem will be implemented and discussed. The prototype system is applied at Solar Energy Department (SED), National Research Centre (NRC) in Giza, Egypt.

I. Calvo et al [8] compared the Wireless communications technology using XBee module to a wired connection made using a NI myDAQ USB-6008 board. Many tests were carried out in order to realize the benefits and problems of these technologies.

They deduced that, in the case of no interferences, the dropout rate was not so critical, for the measured distances, up to 55 meters, and sampling periods, up to 30ms. Furthermore, the flexibility of using XBee antennae is very high, for the reason that wireless technologies allow shifting the devices easily at other locations but a higher delay was created.

The authors believe that a higher speed could increase the dropout. Moreover, it was detected that Wi-Fi caused significant problems of interference with XBee, since both were using the 2.4GHz band. H. Saha et al [9] advises that to utilize the uppermost 25 channels for using the NRF24L01 module because the Wi-Fi devices work on most of the lower channels.

2. PWDAS System Design

2.1. Wireless System

The system was implemented with a tree network topology consisting of two end points, and one Base/coordinator node, see Fig.1. End point 1 is outdoor point and it contains NRF24L01 transceiver, Arduino Uno, MOSFET transistor as a variable electronic load for studying the PV performance. Furthermore, it contains RTC module, D.C. o/p voltages and currents sensors

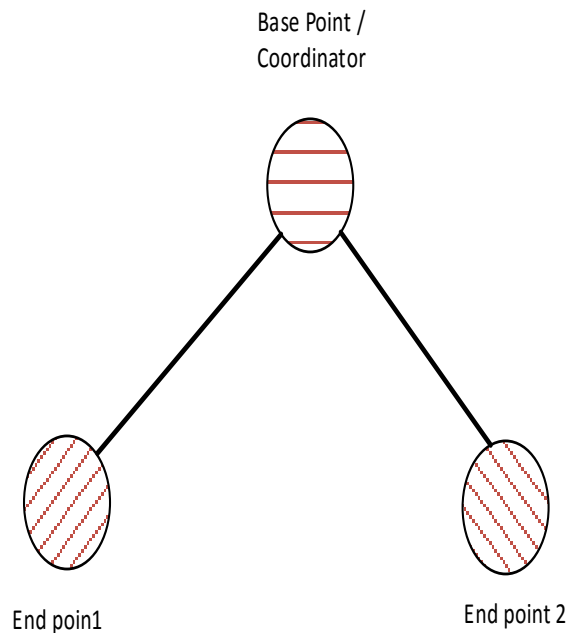

and others. End point 1, is used for gathering the current, voltage of tested PV array. PV analyzer will be discussed in the next work.

End point 2 contains an Arduino Uno as the processor for the connected weather station. The weather station consists of a solar irradiance (S.I.), ambient temperature, Relative Humidity (R.H.) sensors.

The data gathered by the weather station helps to analyze and predict the performance of solar systems in general. At the



Figure 2: NRF24L01 transceiver module

The weather station contains a Light Dependent Resistor (LDR) of high quality for sensing S. I., AM2320 sensor for humidity and temperature sensing placed next to the PV module. The temperature & humidity sensor module, AM2320, has a measuring temperature range of -40 Co to +80 Co with a temperature accuracy of ± 0.5 Co and humidity measurement ranges of 0% to 99.9%, resolution of 0.1%. The base point is indoor at the PV test station and is used to coordinate between the nodes of the network. The node contains an Arduino Uno and connected to the PC via USB.

The acquisition of measurement data from system sensors, which connected to the weather station, are transferred into Excel, at the PC, using the PLX-DAQ Excel Macro using UART bus [10]. Figure 3 shows block diagram of the proposed PWDAS system. The main feature of the proposed technique is its low requirement for hardware elements. Furthermore, this technique makes the visualization of the of PV system

base point, he Arduino was interfaced to the NRF24L01

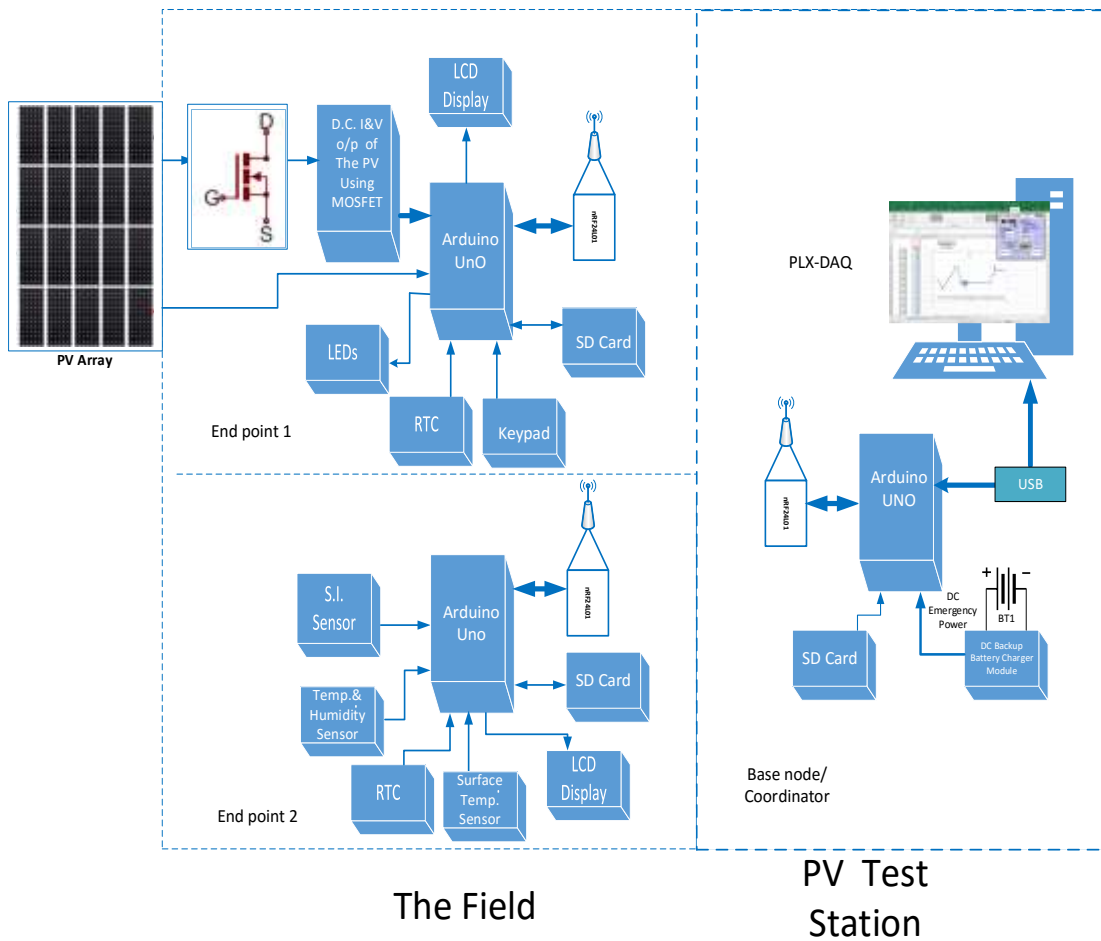

Figure 3: Block diagram of the proposed PWDAS system.

transceiver and configured as an end point 2. Figure 2 shows the NRF24L01 transceiver module.

characteristics for the interested researchers is simpler and faster to use in their work. This technique is more effective compared to the implementation of a virtual instrument system with LabVIEW or MATLAB tools, which require several technical skills and a preliminary training on these tools [11]. In

the current experiment, K type thermocouple plus MAX6675 module is used to sense the PV module surface temperature. The K type sensor has an accuracy of measurement of $\pm 1.5\text{ }^\circ\text{C}$ and resolution of $0.25\text{ }^\circ\text{C}$ and SPI digital signal O/P mode [12].

3. PWDAS Radio Communication

The NRF24L01 2.4GHz wireless data transmission modules are used for conducting the experiments. The modules are produced by NORDIC, working on 2.4GHz~2.5GHz “Industrial Scientific and Medical” (ISM) band. The NRF24L01 wireless transceiver chip built-in frequency generator, enhanced mode controller, oscillators, power amplifiers, modulators and demodulators, that can be directly connected to the microcontroller I/O ports.

Additionally, the NRF24L01 transceiver built-in four work modes that can be configured through the configuration registers. It can work with baud rates from 250 kbps up to 2 Mbps. The range of communications in open area and with lower baud rate can reach up to 100 meters [13].

The wireless communicates with other modules on Channels. Each channel has a predefined frequency. Two or more transceiver modules are communicates with each other on the same channel. The channel frequency should be in the 2.4 GHz ISM band and between 2.400 to 2.525 GHz. Each channel occupies a bandwidth of less than 1MHz. Then, the module can utilize 125 distinct channels and have the possibility to communicate over 125 independently working network in one place, see Fig.4 [13, 14].

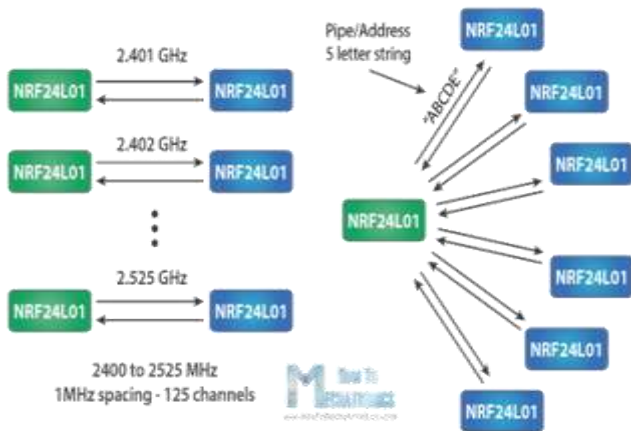

Figure 4: NRF24L01 in a network configuration [13]

Channel frequency number (Ch_{no}) of a selected channel ($Ch_{selected}$) is set using the following equation:

$$ch_{no} = 2400 + ch_{selected} \quad (1)$$

3.1. Weather Station Design (End point 2)

The weather station node consist of Arduino Uno, sensors, LCD display, micro SD module and NRF24L01 radio transceiver module , as in Fig.3. The Uno board is based on the Atmega328 microcontroller. It has a 16MHz clock speed. The board has 14

digital I/O pins, six capable of PWM output, 6 analog I/O pins. The board is programmable with the Arduino Integrated Development Environment (IDE), via a type B USB cable. The analog pins may be used as digital pins. The board can be powered by the USB cable or by 9-volt battery. It accepts voltages range between 7 and 20 volts [14]. The system data is handled with two options; it is either stored in a SD memory card and / or sent wirelessly to the test station. The measured data is recorded with respect to real time using RTC module. The system is able to measure humidity temperature, solar radiation, and wind speed data simultaneously, but wind speed not considered in this work. Arduino Uno supports the Universal Asynchronous Receiver/Transmitter (UART), Inter-Integrated Circuit (I2C), and Serial Peripheral Interface (SPI) communication protocols. These three protocols differ in their implementation, but ultimately serve the same purpose: transferring data at high I2C, and SPI pins on an Arduino UNO. Figure 5 shows the three serial communication protocols which supported by Arduino Uno.

The modes of NRF24L01 module operations are Power Down Mode, Standby Mode, RX mode, and TX mode. Power-Down mode stops all the generated clocks and allows only the operation of asynchronous modules. The transceiver is disabled with current consumption of 0,9 micro Amp.

In power down mode all the register values available from the SPI are maintained and the SPI can be activated.

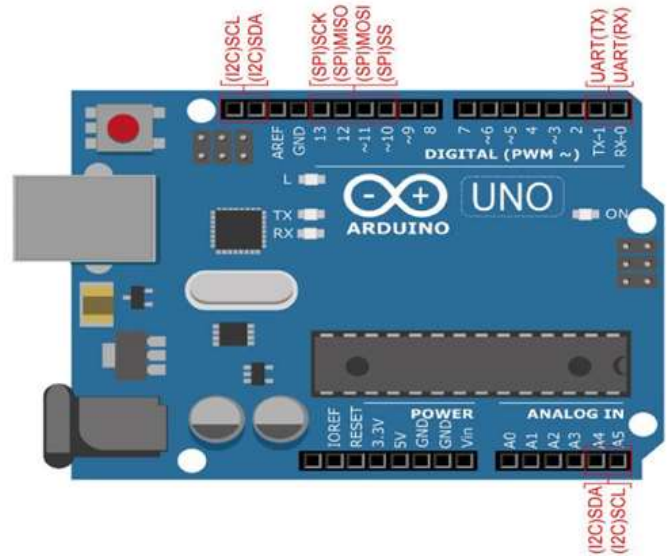

Figure 5: The UART, I2C, and SPI pins on an Arduino UNO.

Standby is used to minimize the average consumption of the current however shorting the startup times. In this mode part of the crystal oscillator is active. The RX mode is applied when the NRF24L01 radio is working as a receiver. The TX mode is applied when the NRF24L01 transmits a packet. NRF24L01 must settle for 1.5ms when it is in power down mode before it can go into the TX or RX modes. In case of using an external clock this delay is minimized to $150\mu\text{s}$ [14, 15].

The NRF24L01, micro SD module and k Type thermocouple module Max6675 are configured and operated through SPI interface. The SPI interface for data and control connections requires the following six signals, except for max6675 module:

- Interrupt Request (IRQ) is not connected,
- Chip Enable (CE) this signal is active,
- Chip select (CSN) active low signal,
- Serial Clock (SCK) signal,
- Master Output Master Input (MOSI) signal,
- Master Input Master Output (MISO) signal.

3.1.1. SPI Slaves Configuration

As discussed above, The NRF24L01 transceiver, micro SD module, and K type thermocouple plus MAX6675 module are configured and operated through SPI serial interface, see Fig.6. The MAX6675 output is 3 signals with simple SPI communication protocol, read only format, to report the measured temperature. In SPI configuration, each slave will be has an individual chip select line. The other pins of the slaves, the SCK, MOSI, MISO, are connected in parallel with the corresponding SPI slave pins. They will be used in a mutually exclusive way under software control, with the Arduino as a master.

To start the transfer of data, the bus master configures the clock using supported frequency by the slave which typically up to a few MHz. The master must select only one slave at a time with a logic level 0 on the select line.

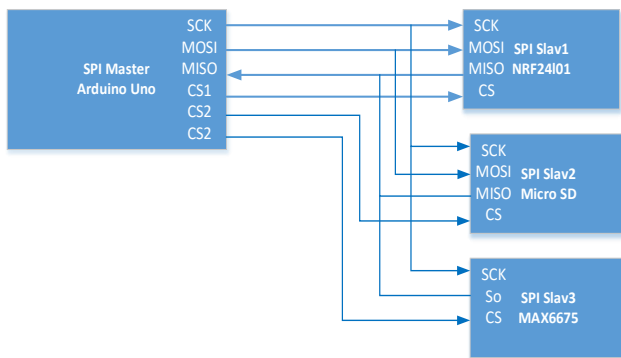

Figure 6: SPI slaves configuration.

If the readings from the sensors required a waiting period, as for analog-to-digital (A/D) conversion, the master must wait for at least that period before generating clock cycles.

3.1.2. I2C Slaves configuration

The I2C protocol grants for the designer to interconnect up to 128 different devices using only two bus lines, one for serial clock (SCL) and the other for bidirectional serial data (SDA). A single pull-up resistor only is required to implement the bus for each of the I2C bus lines. Each sensor connected to the bus must has an individual address [14].

The I2C 1602 serial 16X2 LCD Display, DS3231 module, AM2320 temperature and humidity sensor are configured and operated through I2C serial interface, see Fig.7.

The four wire I2C 1602 serial 16X2 LCD Display is used on the board of node 2 to display the received data from the sensors. The I2C 1602 serial 16X2 LCD Display saves the Arduino pins that occurs from using many wires LCD display.

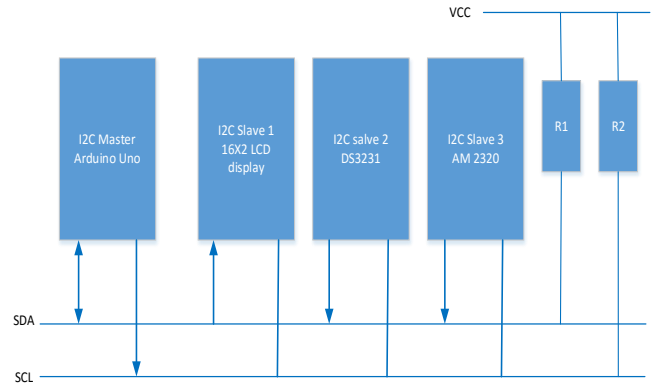

Figure 7: I2C slaves configuration.

This reduced the constrain of utilizing many digital pin and utilize only the power pins (GND pin and 5 V pin), and I2C pins (SDA) and (SCL) for data and clock, respectively. It has a default address of 0x27 [16]. AM2320 temperature and humidity sensor communicates using a single bus, I2C serial interface. It has a default I2C address of 0x5C, which cannot be changed [17]. The I2C address of DS3231, real-time clock (RTC) was determined using the I2C scanner Arduino code, which is 0x57. I2C scanner is simple sketch scans the I2C-bus for devices. It sends to the Arduino serial monitor the 7-bit addresses of the found I2C devices as hexadecimal values [18]. Finally, the LDR sensor is connected to A₀ analog pin of the Arduino as shown in Fig.8. This LDR element is made of a cadmium sulphide or cadmium selenium cell. The resistance of the LDR is inversely proportional to the incident light on its surface. Figure 9 shows the spectrum response of different devices used for irradiance. A sensor with perfect characteristics requires a response of 400 nm to 1200 nm, since 95 % of the solar energy is converted into that wavelength range [19]. The comparison of the graphs of Fig.9 shows that the response of the thermocouple pyranometer is the most proper one. However, the photodiode pyranometer responds with the spectrum from 400 nm to 1200 nm, presenting itself as a good choice of lower cost compared to the thermocouple pyranometer.

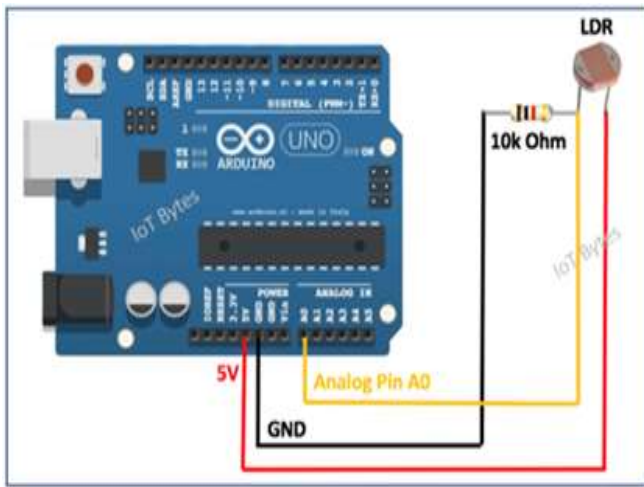

Figure 8: LDR sensor connection to A0.

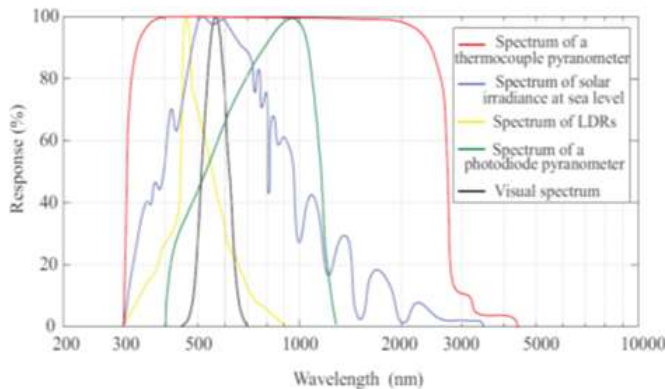

Figure 9: Irradiance spectrum response of the sensors [19].

Finally, the response spectrum of the LDR is within a reduced range of 300 nm to 900 nm. In spite of that, it may be a preferable sensor for its cheap price compared to other sensors.

3.1.3. End Point 2 Power Management

The input voltage to Arduino is limited to 6V : 20V but the recommended value is 7V : 12V. Variable Output DC-DC Step Down Converter module is used to power the weather station, see Fig.10. The module parameters are, 4.5-60V input voltage, 3-35V output voltage, rated current 2A, and Max 15 watt output power. The module gets its input voltage from a PV module and reduces the voltage to the recommended input voltage of the microcontroller board.

3.2. Design of Base/Coordinator Node.

The coordinator node uses an Arduino Uno and NRF24L01 wireless module, which is connected to SPI pins of Arduino. The acquisition of measurements from system sensors, at the weather station, are transferred into Excel, at the PC, as discussed before in section 3.1.



Figure 10: Variable output Dc-Dc step down converter.

During the acquisition process, the data obtained are stored in the Excel spreadsheet in real time.

3.3. PWDAS Software Design

The Arduino UNO was programmed using the open source integrated development environment software (IDE). The ATmega328P microcontroller board of the base unit was interfaced to the PC at the test station using Universal Serial Bus (USB) cable. Then, an integrated circuit ATmega8U2 on the board of the test station connects this serial communication from the Arduino UNO's serial port to the computer's USB port, see Fig.11. The code embedded in the Arduino UNO boards allows to acquire the measured data aggregated by the Arduino Mega of the node 2 and send it to a PLX-DAQ Spreadsheet. The Arduino IDE software is used to write or modify the program code and convert it into instructions which can be uploaded to the system microcontroller board.

The software mainly comprising two modules, one is the measurement module, which gathers analog or digital signals from system sensors to be ready for transmission. The other module is the control module, which receives, displays on LCD at node 2, and then pass them to base node board to store and display on PLX-DAQ spreadsheet and process them.

The flow chart of two modules is shown in Fig.12. It shows two blocks that indicate the process flow in each side. When the programs are activated, the wireless data acquisition system will self-initialize. Then the user can decide whether to acquire data or not.

If acquisition data will be done, program will send a query command to the acquisition module at node 2. The Microcontroller in acquisition system aggregates the intended signals from the sensors. Then the signal is sent wirelessly as acquisition data to user PC. Then by using PLX_DAQ Excel Macro the collected data can be displayed, processed and saved.



Figure 11: PLX-DAQ Excel Macro control window.

4. Results and Discussions

The experiment is carried out by powering weather station unit, End point 2, using a portable power source and DC-DC Step Down Converter module to power it using the PV. While the base unit is connected to the test station PC.

The embedded code into Arduino boards allows to gather the sensors data collected by End point 2 and send it to a PLX-DAQ Spreadsheet at the test station. Figure 13 shows the experimental setup of the PLX-DAQ based PWDAS.

4.1. NRF24L01 Transceiver Range Test

NRF24L01 transceiver module can operate with baud rates from 250 kbps up to 2 Mbps. If it is used in open area and lower baud rate, theoretically, its range of communication can reach up to 100 meters. The actual range test shows, in indoor, the wireless communication range can be reached to 10 meters. While the maximum distance of communication in open area, line of sight communication, can be reached to 37 meters.

The range with the NRF24L01 communication range was improved when a lower bitrate was chosen (250 kbps). And it is advised that to use NRF24L01+ with antenna which has an additional PA (Power amplifier), LNA (Low noise amplifier) to extend range and output power. Temperature and S. I. sensors testing were carried out by comparing the sensors reading value with an accurate mercury thermometer, and photodiode solar meter as a reference.

4.2. Sensors Calibration and Test.

The Wind speed and humidity sensors were not calibrated in this work and they will be calibrated later integrated with the whole PV analyzer system as discussed in point 3.1. Figure 14 shows the calibration and testing of LDR sensor using a solar meter. The solar meter that used to compare with the LDR response has a sensor with a sensitivity degradation of less than

2 % per year and has spectral response from 400 to 1100 nm. The solar irradiance is in units of watts per square meter (W/m²).

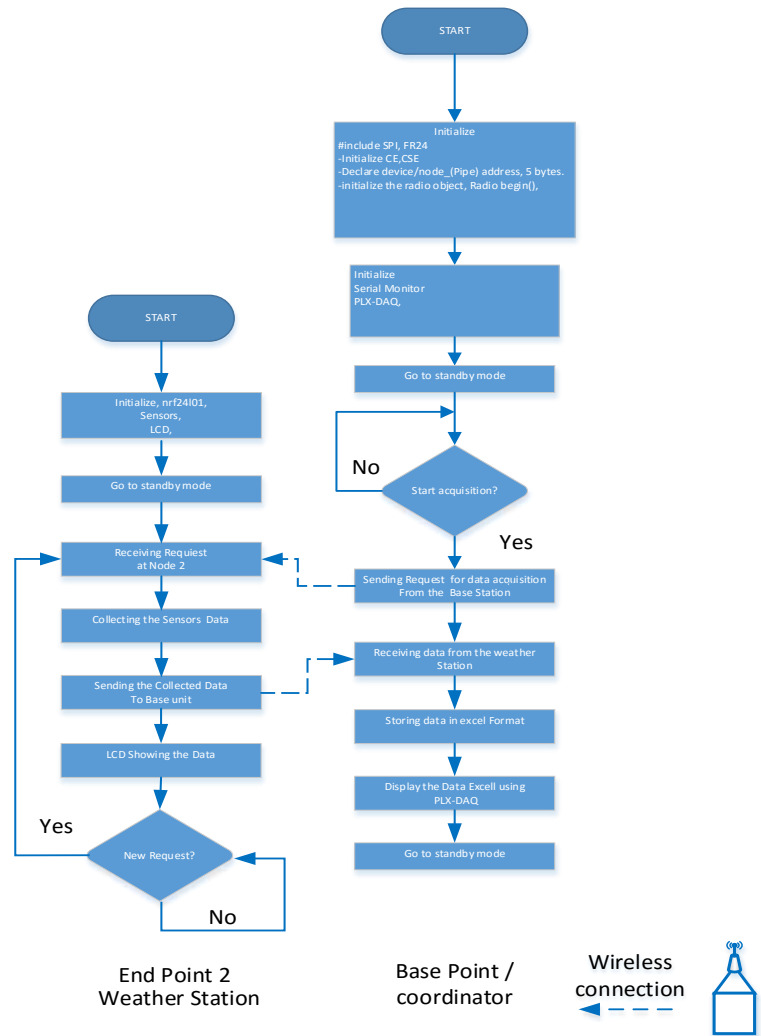

Figure 12: PWDAS flowchart.

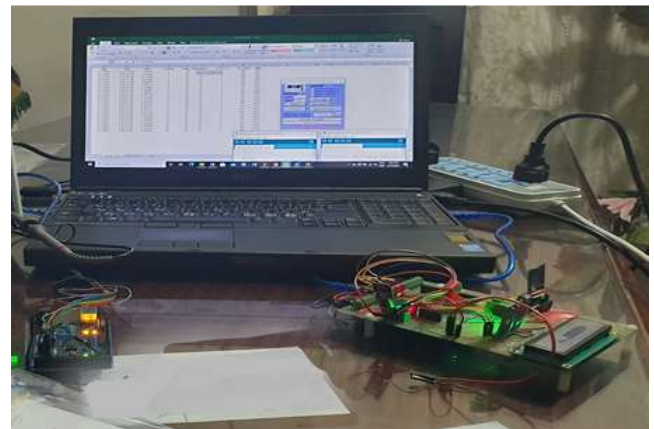

Figure 13: The experimental setup of the PLX-DAQ based PWDAS.

From table 1, the maximum relative error of 6.9 % between the reference solar meter and the LDR readings was evaluated. This relative error is not accepted in the PV system analyzers. To improve the LDR response noise reduction methods should be applied to minimize the conversion noise. Moreover, during the calibration process, the uncertainty of the LDR measurements should be estimated by applying an appropriate correction method to reduce the uncertainties of the measurements and getting the closest value to actual one.



Figure 14: The calibration and testing of LDR SENSOR using a solar meter.

Table 1: LDR sensor test data.

	LDR Sensor W/m ²	Solar meter W/m ²	Relative Error %
1-	801.5	832.1	3.6%
2-	756.2	812.3	6.9%
3-	797.2	794.0	0.4%
4-	651.4	657.0	0.8%
5-	569.0	574.0	0.9%
6-	426.6	419.4	1.7%

Table 2: AM2320 Temperature sensor test and data.

	AM2320 Temperature sensor C°	Thermometer C°	% Error
1-	36.4	36.2	0.54%
2-	34.5	34.4	0.28%
3-	32.5	32.5	0.0%
4-	30.1	30.2	0.3%
5-	29.3	29.6	1.0%
6-	28.6	28.5	0.35%

Table 3: MAX6675 Temperature sensor test data.

	K type thermocouple MAX6675 C°	Thermometer C°	% Error
1-	36.0	36.2	0.55%
2-	34.3	34.4	0.29%
3-	32.4	32.5	0.3%
4-	30.3	30.2	0.3%
5-	29.4	29.6	0.67%
6-	28.6	28.5	0.3%

From Table 2 and Table 3 it can be concluded that the tested temperature sensors were able to sense temperature in degree centigrade with an accepted error. Figure 15 shows the Ambient and PV surface temperatures that received and recorded by PLX-DAT Macro spreadsheet in Thursday, 22 April.

5. Conclusion

The main goal of this research is to develop and implement a PLX-DAQ based wireless weather monitoring system using NRF24L01 transceiver module. From the result obtained throughout the test and experiments carried out

From the result obtained throughout the test and experiments carried out, data sent from the weather station were successfully received at the test station PC and reported to the PLX-DAQ Excel Macro using serial monitor of Arduino IDE.

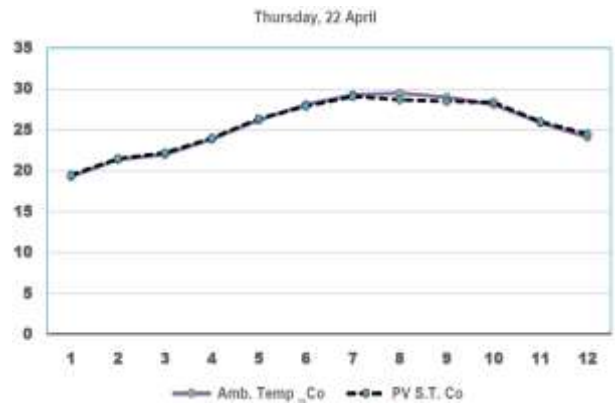

Figure 15: Ambient and PV surface temperatures in Thursday, 22 April.

It is advised to use NRF24L01+ with antenna which has an additional PA and LNA to extend range and output power especially at the areas that have obstacles. In addition, the system has an easy to construct due to the availability of the required hardware and the PLX-DAQ Microsoft Excel macro.

Finally, to get reliable LDR solar meter, the uncertainty of the LDR measurements should be estimated to drive a value from the measurements which is closest to the actual one.

The noise conversion of the LDR sensor data should be minimized and the uncertainties of solar irradiance data should be estimated to enhance the performance of the LDR solar meter.

Conflict of Interest

International Conference, DOI: 10.1109/INDUSCON.2018.8627176, pp. 1-8, 2018.

The authors declare no conflict of interest.

References

- [1] E. Bellinie, Egypt could reach 44 GW of solar by 2030 – IRENA , PV Magazine OCTOBER 9, 2018, <https://www.pv-magazine.com/2018/10/09/egypt-could-reach-44-gw-of-solar-by-2030-irena/>. (Article)
- [2] S. Parashar, S. Dhankha, "Data Acquisition and Analysis of Solar Photovoltaic System", International Journal of Information & Computation Technology, vol. 4, No. 14, pp. 1453-1458, 2014.
- [3] P. Park, S. C. Ergen, C. Fischione, C. Lu, and K. H. Johansson, "Wireless Network Design for Control Systems: A Survey," IEEE Commun. Surv. , DOI: 10.1109/COMST.2017.2780114 , vol. 20, NO. 2, pp. 1–36, 2017.
- [4] Isidro Calvo1, Steven Abrahams, Oscar Barambones, Ander Chouza1, Javi Velasco, Idure Sáez de Ocáriz3, Jerónimo Quesada, "A COMPARISON OF WIRED AND WIRELESS TECHNOLOGIES FOR CONTROL APPLICATIONS", DOI:10.17979/spudc.9788497497565.0538, Actas de las XXXIX Jornadas de Automática, Badajoz, 5-7 de Septiembre de 2018".
- [5] N. Mahzan, A. Omar, L. Rimon, S. Noor, M. Rosselan," Design and Development of an Arduino Based Data Logger for Photovoltaic Monitoring System", International Journal of Simulation: Systems, DOI: 10.5013/IJSSST.a.17.41.15, 2017.
- [6] B. Jiang and M. Iqbal, "Open Source Data Logging and Data Visualization for an Isolated PV System", Electronics ; doi:10.3390/electronics80404244, vol. 8, No. 4, pp 424, 2019.
- [7] T. Singh, R. Thakur, " Design and Development of PV Solar Panel Data Logger", vol. 7, No.4, 2019.
- [8] I. Calvo, S. Abrahams, O. Barambones, A. Chouza1, J. Velasco, " A COMPARISON OF WIRED AND WIRELESS TECHNOLOGIES FOR CONTROL APPLICATIONS", doi.org/ 10.17979/spudc.9788497497565.0538, Actas de las XXXIX Jornadas de Automática, pp. 535-545, 2020.
- [9] H. Saha, S. Mandal, S. Mitra, S. Banerjee, U. Saha," Comparative Performance Analysis between nRF24L01+ and XBEE ZB Module Based Wireless Ad-hoc Networks", I. J. Computer Network and Information Security, DOI:10.5815/IJCNIS.2017.07.05, vol. 7, No. 5, pp36-44, 2017.
- [10] Parallax Inc., Parallax Data Acquisition tool (PLX-DAQ) software, PLX-DAQ version 2, <https://www.parallax.com/package/plx-daq/>.
- [11] El Hammoui*, S. Motahhir, A. Chalh, A. El Ghzizal and A. Derouich, " Low-cost virtual instrumentation of PV panel characteristics using Excel and Arduino in comparison with traditional instrumentation", El Hammoui et al. Renewables vol. 5 No.3, 2018.
- [12] Cold-Junction Compensated Thermocouple-to-Digital Converter, Datasheet <https://datasheets.maximintegrated.com/en/ds/MAX6675.pdf>. (Datasheet)
- [13] Dejan, nRF24L01 How It Works, Arduino Interface <https://howtomechatronics.com/tutorials/arduino/arduino-wireless-communication-nrf24l01-tutorial/>.
- [14] J. Hughes , "Arduino A Technical Reference: A Handbook for Technicians, Engineers, and Makers", 1st Edition, USA, 2016.
- [15] R. Luiz Ximenes , G. Meceneiro , B. Conrado , L. Roger , T Santos "Development and assembly of Radio Frequency Module using components with SMD technology for educational purposes", Vol. 11, No. 1, pp. 1304-1310, 2017.
- [16] I2C 1602 Serial LCD Module, <https://opencircuit.shop/resources/file/da88acc1702a90667728fcf4ac9c75c455475706466/I2C-LCD-interface.pdf>.
- [17] Digital Temperature and Humidity Sensor AM2320 Product Manual, <https://cdn-shop.adafruit.com/product-files/3721/AM2320.pdf>.
- [18] Extremely Accurate I2C-Integrated RTC, <https://www.es.co.th/Schemetic/PDF/DS3231.PDF>.
- [19] R. Barros, J. Callegari, D. Mendonc, W. Amorim, M. Silva, H. Pereira, "a Low-Cost Solar Irradiance Meter using LDR Sensors",13th IEEE/IAS