

MILITARY TECHNICAL COLLEGE
CAIRO - EGYPT7th INTERNATIONAL CONF. ON
AEROSPACE SCIENCES &
AVIATION TECHNOLOGY**EXPERIMENTAL INVESTIGATION OF RADIAL TURBINE CHARACTERISTICS****A. M. Namet-Allah*, A. M. El-Zahaby **, S. S. Kossa *******ABSTRACT**

In order to evaluate the performance of a radial turbine, its characteristics should be determined carefully. In turbines the flow is compressible, three-dimensional, viscous, and turbulent. The gas passages are closely spaced with blades having high aerodynamical and structural loading. The turbine characteristics need a practical determination under controlled environment so a test rig is built enclosing two basic parts, the first is for conditioning the flow passage through the turbine model, the second is for measuring the flow parameters needed to evaluate the turbine characteristics. The measured data includes the static and total pressures, the inlet and outlet temperatures, the turbine model revolutions, and the mass flow rates of air. These data are recorded and processed using a personal computer. A theoretical study was performed in previous work in order to predict the turbine characteristics. The measured characteristics have been used to evaluate and confirm the theoretical prediction of the same turbine.

KEY WORDS

Radial turbine characteristics

1- INTRODUCTION

The radial turbine is suitable for many applications in aircrafts, space power systems, and other systems where compact power sources are required. Turbines of this type have numbers of desirable features such as high efficiency, easy manufacture, strong construction, and high

* Teaching Assistance in Aeronautical Department M.T. C. Cairo Egypt,

&* Professors, Aeronautical Department M.T. C. Cairo Egypt.

reliability. In radial turbines the flow enters the stator radially and leaves the rotor axially. This change of flow direction takes place in the rotor, which is relatively long and narrow. The flow through the stator and rotor is unsteady, viscous, compressible, and three-dimensional through geometrically complex passage. So the turbine characteristics are determined experimentally. In previous works the characteristics of radial turbines were obtained by studying the effect of the specific speed on the turbine efficiency (η_{Tc}) [1]. Also the effect of blade-to-shroud clearance at the rotor inlet and exit sections on the efficiency of radial turbine was determined experimentally [2]. In the present work the turbine characteristics are measured in the form of the change of expansion ratio (π_{Tc}) and the variation of the total temperature drop ratio as function of the reduced mass flow rate (m_r). The measurements are carried out at different speed parameters.

2. EXPERIMENTAL TEST RIG

The experimental test rig is built in the aeronautical laboratory of M.T.C in order to perform the experimental investigation of radial turbines. Fig.1, illustrates the layout of the experimental setup and Fig.2, shows photos of the experimental test rig. The turbine model(14) is placed inside the test section as shown in Fig.1. This turbine model is driven by air coming from root compressor(1) which is driven by 3-phase variable speed "Schraga" motor(4) through a lubricated sprocket chain system. The air passes from the root compressor(1) to the air box(24) where four coil heaters are fixed inside it in order to keep the homogeneity of the air temperature, as shown in Fig.3. The turbine model is loaded by a radial compressor(12) which is controlled by a manual gate valve(17) which is assembled in the compressor outlet pipe. The lubricating system consists of a gear pump(19) which is driven by 3-phase electric motor(21). The lubricating oil passes to the TURBOCHARGER and the Sprocket-chain system(2) through the pressure line and return to the main oil tank(8) throughout the return line(6). A schematic drawing of the rotor and casing of the turbine are shown in Fig.4.

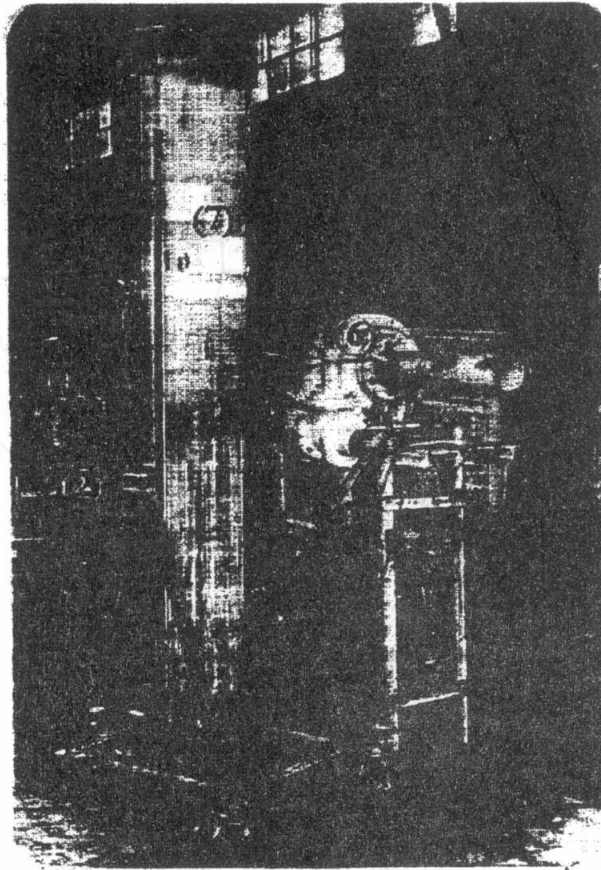
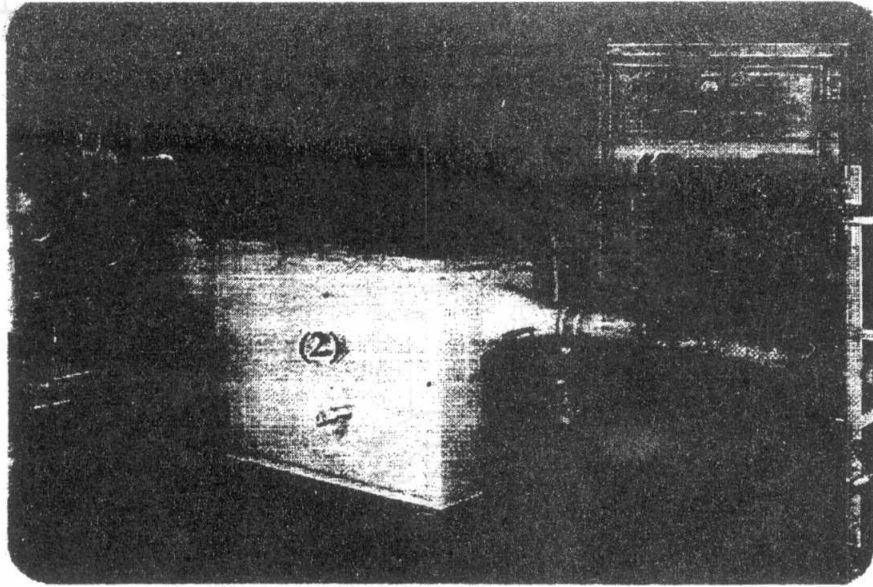

- | | | | |
|---|-----------------|---|----------------------|
| 1 | Root Compressor | 5 | Transformer |
| 2 | Air Box | 6 | Tested Turbine Model |
| 3 | Shraka Motor | 7 | Water Manometer |
| 4 | Control Panel | | |

Fig. 2 Experimental Setup View Pictures

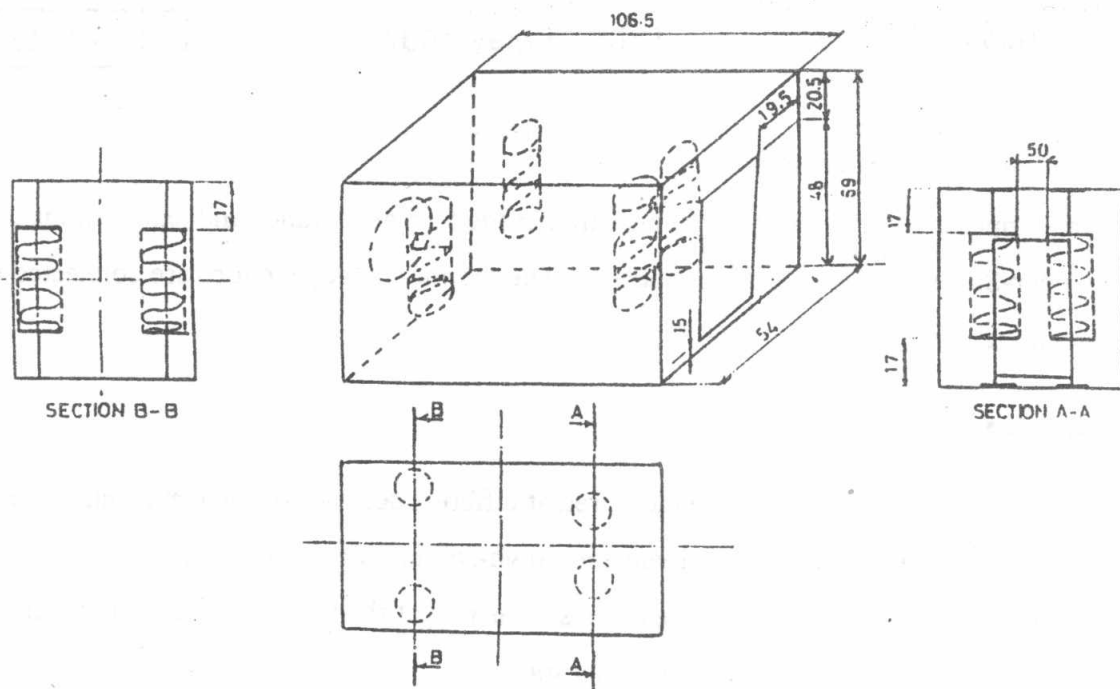

Fig.3. Heat Distribution

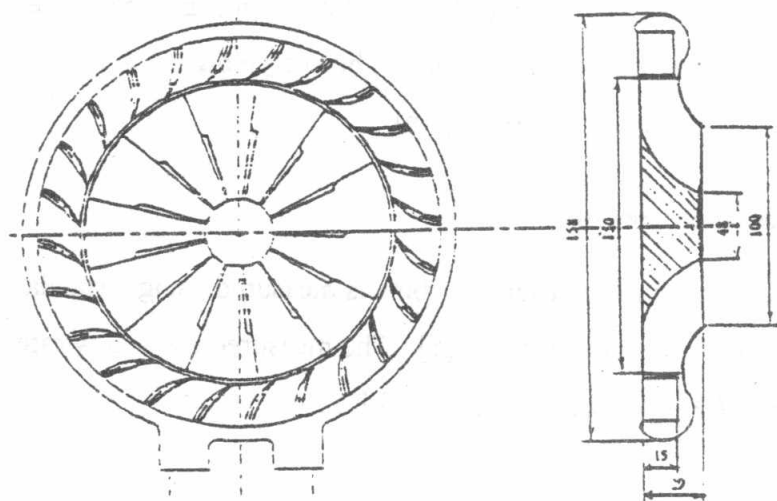

Fig.4. Impeller and Casing Drawing

3. MEASURING INSTRUMENTS AND CONTROL

The measuring parameters include temperature, pressure, speed of revolutions, and the mass flow rates. During the performance measurements, the speed of the main motor, the speed of the measured turbine, and the temperature of the turbine inlet flow should be controlled.

3.1 Temperature Measurements

The total temperature of the air flow is measured at the turbine entrance and exit sections using two Copper-Silver thermocouple junctions[4]. The thermocouple junctions are connected to a digital readout of range -50 to +1200 C°.

3.2 Pressure Measurements

Both the static and total pressures are measured at different sections of the test stand. The static pressure is measured at the upstream and down-stream of an orifice meter by using the vertical water manometer. The total pressure is measured at the turbine entrance and exit sections by using the vertical water manometer too .

3.3 Speed Measurement

The speed of the root compressor is measured by a touch type digital tachometer of accuracy ± 0.1 r.p.m. (0.5 to 500 r.p.m), ± 1 r.p.m. (1000 to 5000 r.p.m), $\pm 0.05\%$ (over 5000) , and the speed of the radial turbine model is measured by a photo type digital tachometer of accuracy ± 1 r.p.m(5 to 5000r.p.m), $\pm 0.05\%$ (over 5000r.p.m).

3.4 Mass Flow Rates Measurement

The mass flow rates through the measured turbine is measured using a standard and calibrated orifice meter placed at the turbine entrance,[5]. The measured mass flow rates are reduced to the standard conditions ($P_s = 101320 \text{ N/m}^2$, $T = 288 \text{ K}$).

3.5 Controlling Devices

The main motor speed control for the root compressor is used to obtain different expansion ratios for the turbine. The change of motor speed based on changing the relative angular locations of the motor brushes[6]. The turbine speed control is reached by selecting the regime of the load compressor through a flow control valve(17), as shown in Fig.1. The turbine total flow temperature at inlet section is selected by operating some or all coil heaters inside the air box[3].

4. EXPERIMENTAL PROCEDURES

The turbine characteristics represent the variation of expansion ratio and the total temperature drop ratio as function of reduced mass flow rate m_r , and speed parameter.

where:

$$m_r = m \sqrt{\frac{T_{oc}}{288}} \cdot \frac{101320}{P_{oc}}$$

The characteristics of the radial turbine are measured in three cases; first, without heating (atmospheric conditions); second by using two coil heaters, and third by using four coil heaters.

For each case the following procedures are done:

- a- Selection of the root compressor speed and measurement of the flow parameters at the radial turbine entrance and exit sections. The measured flow parameters are the static and total pressures, the static and total temperatures, the mass flow rate, and the speed of revolutions of the turbine.
- b- Calculations of the turbine speed parameter.
- c- Changing of the mass flow rate through the turbine by the manual gate valve. According to this change in mass flow rate, the values of the measured parameters change, so the value of the turbine speed parameter changes too.
- d- Changing of the regime of the root compressor in order to reach the calculated value of turbine speed parameter by varying the air mass flow rate using the flow control valve.
- e- Measurement of all the flow parameters to get another point on the turbine characteristic's map.

5- RESULTS.

The measured turbine characteristics are depicted in Fig.5, and Fig.6 for different values of speed parameter ranging from 412 to 425. These results are compared with the obtained theoretical calculations[3] of the same turbine operating at the same speed parameters. This comparison are depicted in Fig.7, and Fig.8.

This turbine characteristics are measured at small range of mass flow rate limited by the operating range of the root compressor. The errors encountered with the measured parameters, in the experimental work are evaluated. They found for the expansion ratio equal to 0.0077%, the mass flow rate equal to 0.565%, and for the total temperature drop ratio equal

to 0.0077%. Such errors are evaluated by the help of their dependents on the accuracy of the used instruments.

CONCLUSIONS

An experimental study of a radial turbine characteristics was performed. A test stand was erected and provided with precise instruments necessary to measure the static and total pressure, static and total temperatures, mass flow rates, and the speeds of revolution. The turbine characteristics are measured at different atmospheric conditions, speed parameters, and mass flow rates, they are reduced to the corresponding values of the standard atmosphere. The range of the measured characteristics is limited by the possible operating range of the root compressor.

REFERENCES

- [1] Benson, R. S., "An Analysis of Losses in Radial Gas Turbine," Proc. Inst. Mech. Eng., VI. 180(pt.3j), p. 53, (1966).
- [2] Rodgers, C., "Efficiency and Performance Characteristics of Radial Turbines," Paper. 660754, SAE, (1966).
- [3] Namet-Allah A. M., "Theoretical and Experimental Investigation of a Radial Turbine Characteristics" MSc Thesis, M.T.C, (1996).
- [4] Ghenaiet A., "Study of Radial Flow Compressor Unstable Characteristics," MSc Thesis, M.T.C, (1991).
- [5] Khaled S, "Theoretical and Experimental Investigation of Radial Turbomachines," Ph.D. Thesis, M.T.C (1991).
- [6] Elzahaby A., " Experimental Study of a radial Flow Compressor Unstable Characteristics," ASME Periodicals, Modeling, Measurement and Control, C, Vol. 41 PP. 1-15, Lune, France, (1994).

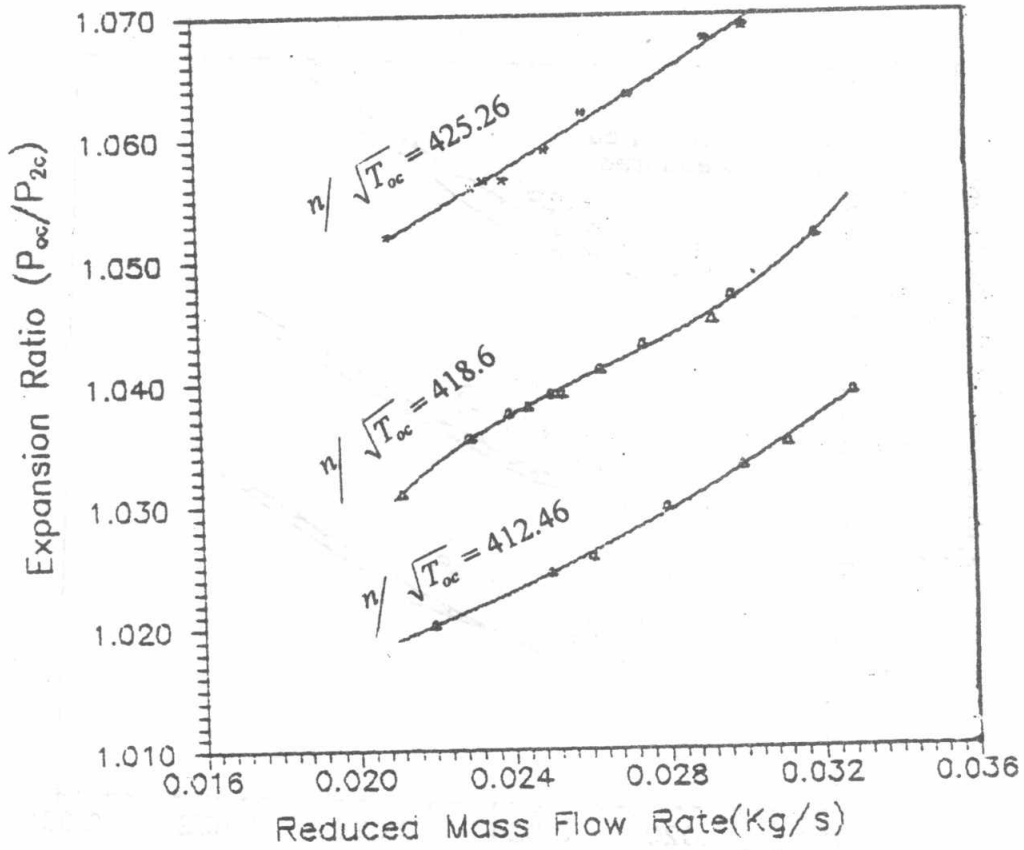

Fig.5. Measured Turbine Characteristic

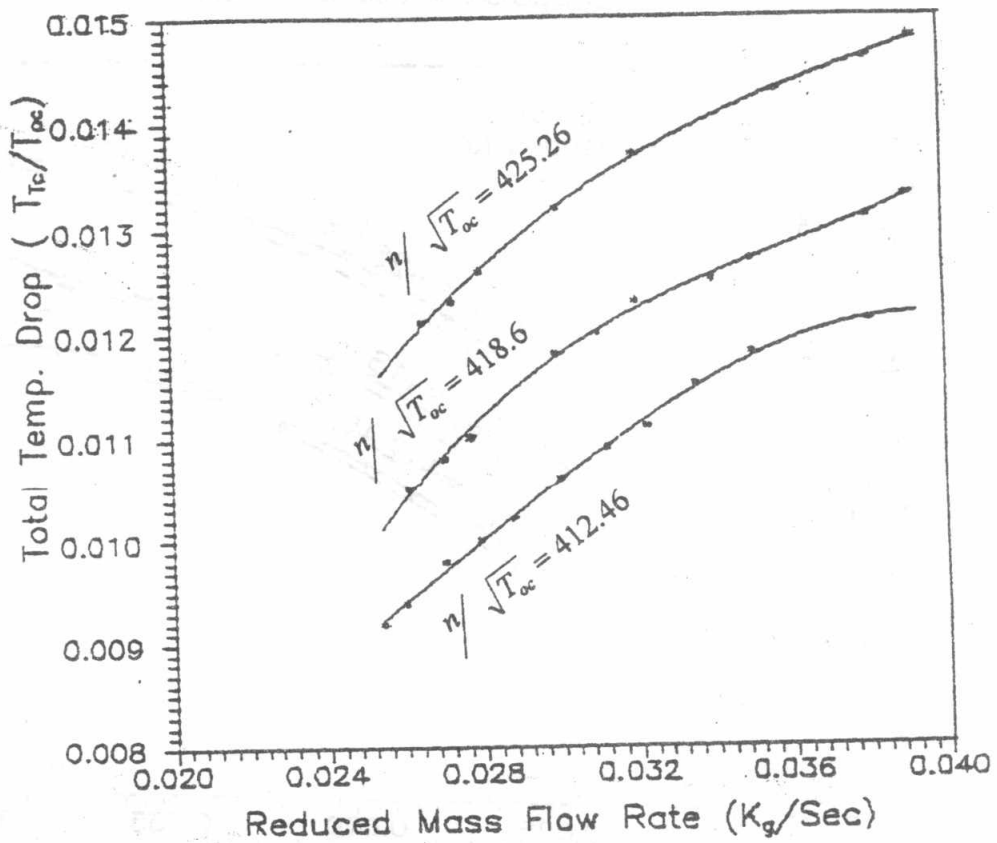

Fig.6. Measured Total Temperature Drop

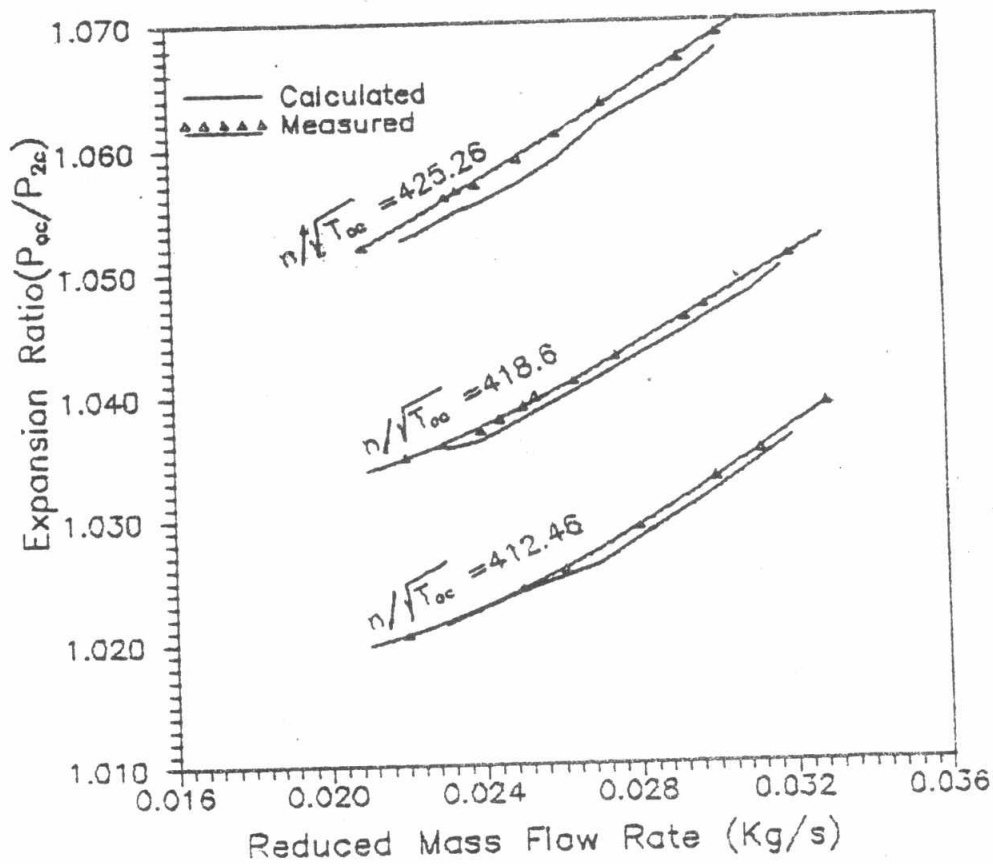

Fig 7. Comparison Turbine Characteristics

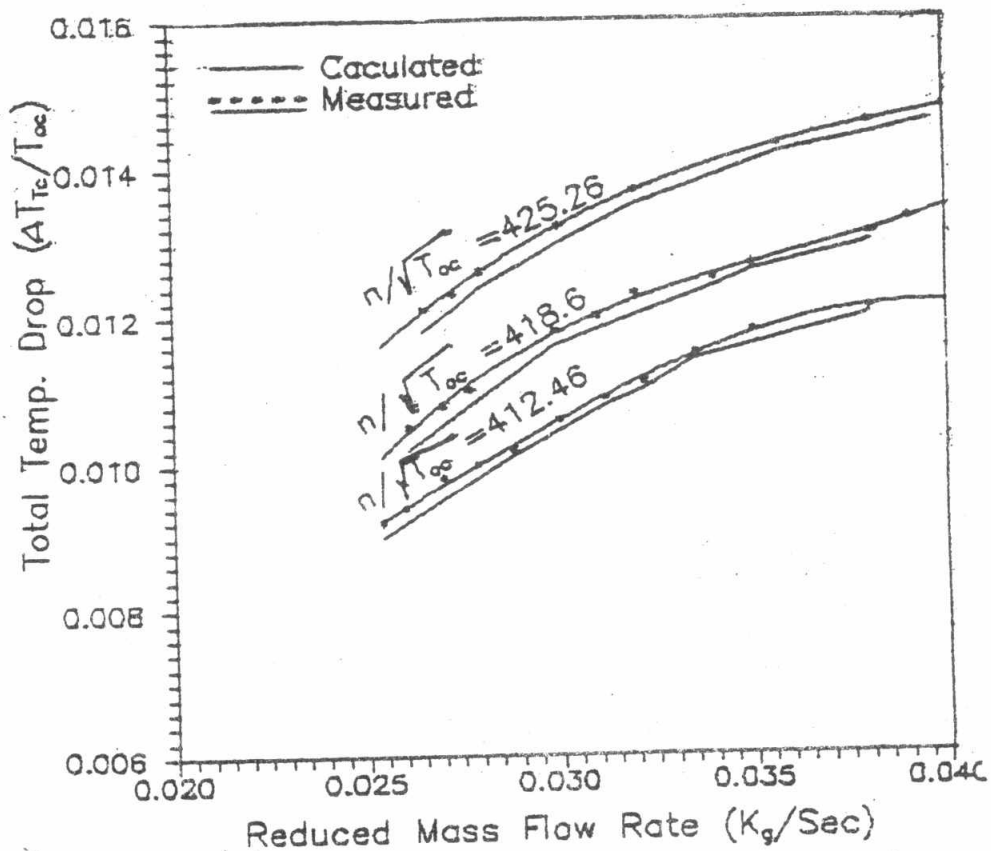

Fig. 8 Comparison of The Turbine Total Temp. Drop Ratio