

LDV IN HIGH ASPECT RATIO CURVED DUCTS
WITH RECTANGULAR CROSS SECTION

O. E. ABDELHAMID*

ABSTRACT

Results of LDV measurements in the incompressible flow field inside two different curved ducts of C and S shapes are provided. Ducts are of high aspect ratio rectangular cross section intended for isolation of secondary flow effects. Measurements are performed using single component He-Ne forward scatter LDV system. The system operates in dual beam fringe mode with signal processing by counting. Mean streamwise velocity profiles and turbulence intensities are obtained at different streamwise locations together with several lateral traverses. Measurements are performed in conditions of moderately turbulent boundary layers on duct walls and manifested the curvature effects on internal flow and boundary layer behaviour. Lateral traverses indicated the presence of Görtler vortex system expected on concave walls at such moderately turbulent Reynolds' number. Obtained results clarify the flow nature in curved ducts and help in setting and checking the relevant computational codes.

INTRODUCTION

Curved ducts for flow passages are currently appearing in several industrial applications. In aeronautical industry they form an important topic of engine airframe integration. Engine performance and efficiency are strongly affected by flow conditions in the intake system, fan bypass ducts and the exhaust systems of its fixed or vectored thrust nozzles. Theoretical and experimental investigations of flow in such ducts are necessary for the improvements of their design, minimization of occurring pressure losses, reduction of distortion and increasing the flow rate. Theoretical solutions of flow in such ducts are amenable through complicated analytical procedures and computational techniques. Experimental investigations play an important role in helping the theoretical flow dealers by giving the necessary data for setting and checking their solutions, computational codes and turbulence models.

* Professor and Chairman, Department of Aeronautical Engineering, MTC, Cairo, EGYPT.

Laser Doppler Velocimetry (LDV) has an increasing potential in internal flow measurements, especially where it is not easy to access with measuring probes to measuring locations and when unaffected flow conditions due to probe presence are to be maintained. The aim of this work is to obtain results of sufficient details and accuracy necessary for understanding flow nature in selected two different curved ducts and comparing the effects of duct curvature on potential core and wall boundary layers.

It is already known that stability of boundary layers on curved walls is affected by the developing radial pressure gradient where marked differences occur in turbulent velocity profiles with respect to straight walls. In addition to curvature effects, flow fields in curved ducts with circular or square cross sections are affected by secondary flows arising in such low aspect ratio section shapes. For isolation of secondary flow effects and investigating curvature effects only, measurements in curved ducts with high aspect ratio rectangular cross section is proposed.

EXPERIMENTATION AND MEASURING SETUP

During the experiment, streamwise mean velocity profiles, turbulence intensities and lateral traverses of flow field were investigated using LDV in a C-shaped and S-shaped curved ducts with high aspect ratio rectangular cross section. Geometry and orientation of both ducts during test are shown in Fig.1.

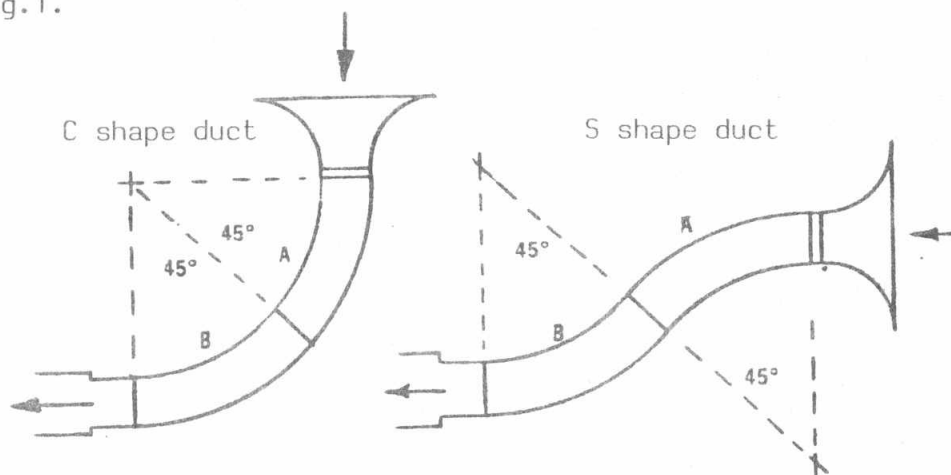

Fig.1. Geometry and orientation of tested ducts.

Ducts are constructed from two identical 45 degree bends A & B of same rectangular cross section 10 cm x 55 cm inner dimensions. Mean radius of bends is 50 cm giving a ratio of 5 to duct height. The two bends are clamped tightly together alternatively to form the two different passage shapes with no gaps or discontinuity in duct walls. The S shape duct inflection plane is thus at the junction of the two bends. Duct walls are made of plexiglass for optical access. A bell mouth with all side walls of constant radius 50 cm followed by 2.5 cm straight section was used to direct the flow of air in the duct system. Turbulence strip made of 0.5 mm shimstock protruding into the passage was fitted between the bell mouth and duct entrance for insuring turbulent boundary layer from beginning of duct walls.

Air is inducted through the test ducts by the subsonic wind tunnel at Aerospace Sciences Laboratory of Purdue University, U.S.A. where the

measurements were performed. Ducts are connected to tunnel wall through a wooden exit extension and adaptor ducts which are vibration isolated (Fig.2.). Screens after the duct system in the exit extension assure uniform exit conditions for the duct flow. Pitot static tube sensing the dynamic pressure at duct exit serves as feedback link to tunnel controller system which serves to maintain constant dynamic pressure during test. Tunnel was running at about 900 r.p.m. of its fan resulting in mean velocities at duct centerline 33 m/sec. With reference length taken as half duct height (5 cm), the test Reynolds' number is equal to $Re = 85000$. The Dean number based on this value and the given ducts' geometry is

$$De = \sqrt{\frac{0.5 H}{R_c}} Re \approx 27000$$

where H is the duct height (10 cm)
 R_c is the mean radius of duct curvature (50 cm)

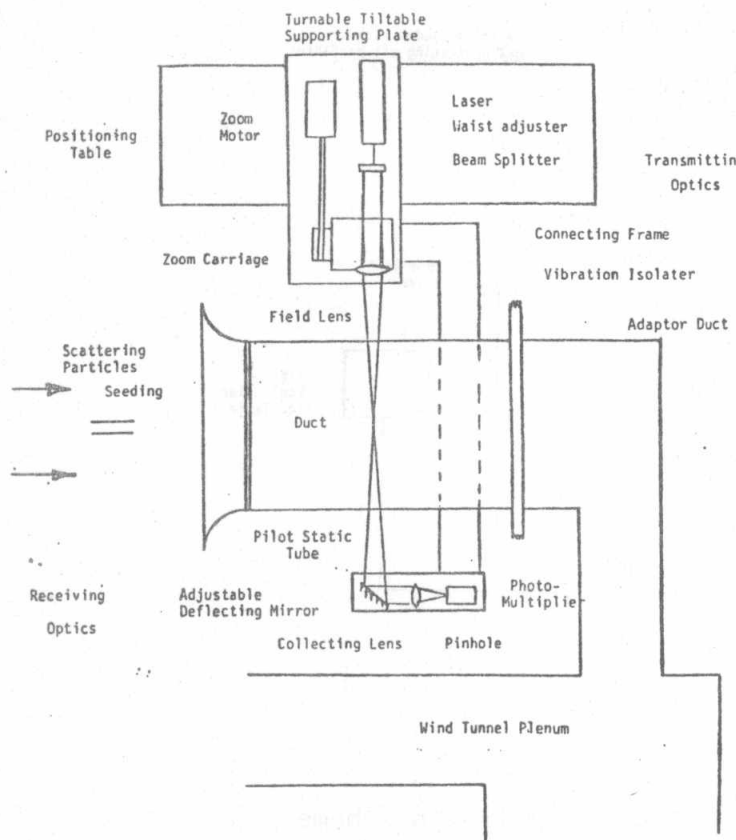

Fig.2. Schematic drawing of test arrangement.

Flow mean streamwise velocities and turbulence intensities were obtained using a single color LDV system. The system is operating in the forward scatter dual beam fringe mode with counting signal processing. It is constructed in the laboratory and is shown schematically in Fig.3. The system comprises a laser light source, transmitting and receiving optics, and counter signal processor. The light source is the Spectra -Physics Model 124A Helium Neon laser of stabilized power 15 mw. Beam of red light with wave length 6328 A is produced. Transmitting optics consists of beam waist adjuster directly mounted on the laser outlet, two prism beam splitter allowing rotation around optical axis and a zooming field lens fixed to a computer controlled axially shiftable mount. Optical axis is adjusted normal to flat side walls of duct. The two split beams are focused intersecting into an ellipsoidal probe volume with a single set of fringes. Receiving optics at the other flat side wall are composed of high quality deflecting mirror of adjustable tilt, a collecting convex lens and a photomultiplier ISI model 962 with pinhole.

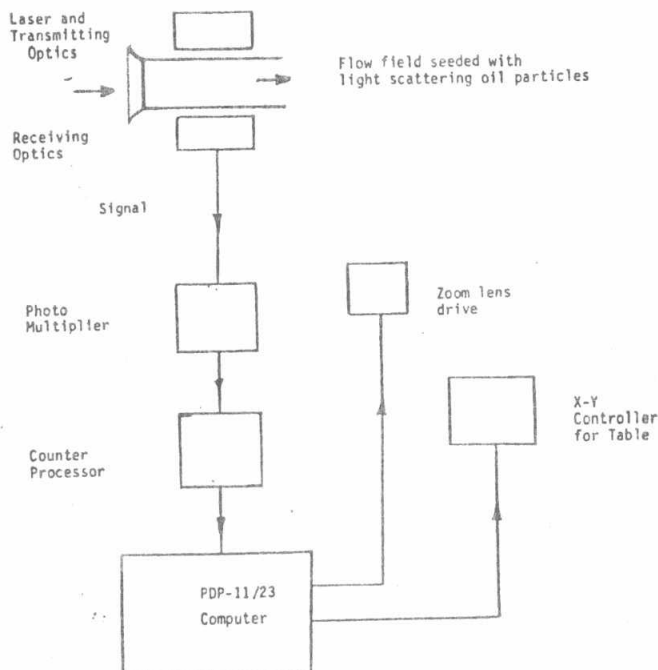

Fig.3. LDV system instrumentation scheme

Package of receiving optics is rigidly connected to the computer controlled zooming carriage of transmitting optics field lens by a U-shape frame of light cylindrical sections. Through such connection, same and simultaneous shifting of probe volume and receiving optics is performed by a single drive at side of transmitting optics, making any readjustments during test unnecessary. Laser, transmitting and receiving optics and the zooming electrical drive are fixed to a supporting flat plate mounted on a two axis computer controlled electrically motorized positioning table. Plate mounting allows slight tilting

and rotation. Table horizontal and vertical translations together with zooming of transmitting optics field lens , rotation of beam splitter , tilting and turning of supporting plate , complete the six degrees of freedom of probe volume.

Principal characteristics of optical system are given by:

| | | |
|---------------------------------------|--------|----------------|
| Focal length of field lens | 600 | mm |
| Beams intersection angle | 5.8765 | degrees |
| Number of fringes in measuring volume | 20 | fringes |
| Fringe spacing | 6.173 | microns |
| Probe volume diameter | 0.121 | mm |
| Photomultiplier pinhole diameter | 0.025 | mm |
| Doppler conversion constant | 0.154 | MHz per m/ sec |

A smoke generator ,with its hose exhausting upstream of the duct bellmouth intake,seeds the inducted air flow with light scattering oil particles. Used oil is a petroleum distillate type 1964 Fog Juice. Particle diameter is less than 2 microns,they reach the control volume at concentration 10000 particles per mm³.

Image of scattering is picked up through the photomultiplier pinhole and processed by a counter type signal processor TSI model 1980 with input conditioner model 1984 and timer model 1985. Input conditioner makes an envelope to the time to be measured and the timer measures this envelope utilizing a high speed clock (250 MHz). The input conditioner also filters the input burst signal from D.C. pedestal (high pass filter) and from high frequency noise (low pass filter). The timer includes minimum cycles per burst selection,comparison circuitry,data ready output and analog output of time and frequency. During test,signal processor was working with following conditions

| | |
|-------------------------|----------|
| Comparator setting | 1% |
| High pass filter at | 1 MHz |
| Low pass filter at | 10 MHz |
| Minimum cycle per burst | 8 cycles |

The whole series of measurments was performed in the frequency range from 2.5 MHz to 4.5 MHz. Gain of signal conditioner is set to its most possible low values for decreasing its output noise which decreased data rate (less than 100 /sec) and increased sampling time (60 sec / measuring point).

Long time sampling resulted in less discrepancy and more suitability to the stationary character of measured turbulence. Amplifier gain has to be slightly increased when measuring near duct walls in order to maintain acceptable data rate and reasonable time of tunnel run.

Digital output of signal processor is fed to the laboratory computer PDP 11/23. The computer manipulates the test procedure, controls the motorized table and zoom lens motion,performs data aquisition and stores the results on disc files. At each measuring point, samples of 1000 data were collected from which mean velocity and the RMS were calculated. Turbulence intensities are evaluated as ratio of RMS to local corresponding mean velocity. Special template is produced for adjusting beam setting at individual measuring sections. The template enables setting the beams such that fringe system is normal to streamwise velocity direction with accuracy up to half degree. Photographs showing the test arrangement are given in Fig.4. Left hand side picture shows the S shape duct connected through the wooden extension to wind tunnel plenum. Picture also shows the positiong table ,laser and optics. Right hand side picture shows the electronics set up ,signal processors and computer control of positiong table. In this picture is also seen the arrangement for seeding the duct flow with light scattering oil particles.

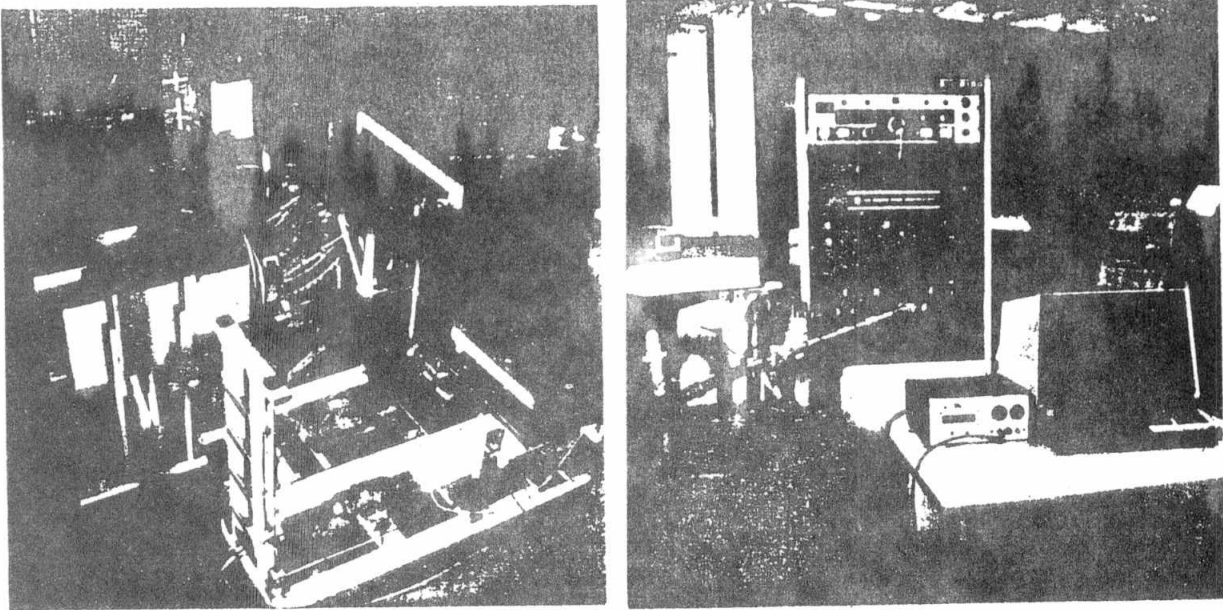

Fig. 4. Layout of test arrangement and electronics setup.

RESULTS

The adopted system of coordinates is shown in Fig.5. Streamwise section locations are determined as the angular displacement of the radius vector with origin at center of duct curvature θ ($\theta = 0.0$ degree at duct inlet and $\theta = 90.0$ degree at duct exit section respectively). Junction and inflection sections being at $\theta = 45$ degree. Radial coordinate y is measured normal to duct curved walls, being $y = 0.0$ mm at the lower wall and $y = 100$ mm at the upper wall. Spanwise coordinate z is measured normal to the flat side walls with $z = 0.0$ mm at the duct plane of symmetry.

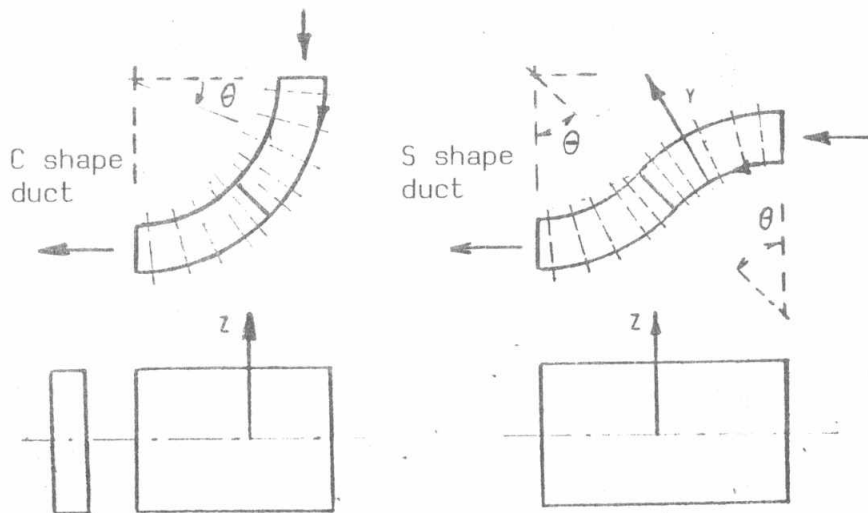

Fig. 5. The adopted system of coordinates.

C Shape Duct Measurements : For investigating the streamwise flow character in duct's plane of symmetry ($z = 0.0$ mm), velocity profiles and turbulence intensities are obtained at $\theta = 5.0, 15.0, 25.0, 35.0, 40.0, 50.0, 55.0, 55.0, 65.0, 75.0,$ and 85.0 degrees. Data are taken at radial steps $y = 1.2$ mm decreased to $y = 0.5$ mm in regions of steep velocity gradient near the walls. Within each cross section ,probe volume was brought as near as 2mm to the concave wall and 1 mm to the convex wall. Results are given in Fig.6. For investigating the spanwise flow character mean velocity and turbulence intensity profiles are measured at both sides of plane of symmetry ($z = \pm 25$ mm) at two streamwise locations near duct inlet ($\theta = 5.0$ and 15.0 degrees) and at duct exit ($\theta = 75.0$ and 85.0 degrees), see Fig.7 . Lateral traverses of streamwise velocity are performed inside boundary layer on concave wall in regions far from side flat walls. These traverses are done at three streamwise sections at different heights from the lower C shape duct wall. Results are given in Fig.8.

S Shape Duct Measurement: Streamwise flow character is investigated through similar measurements taken at streamwise locations $\theta = 25.0, 35.0, 40.0, 50.0, 55.0, 65.0, 75.0,$ and 85.0 degrees. Results are given in Fig.9.

Error Estimations:

Unertainty in the LDV data is referred to

- a- signal processor resolution.
- b- RMS of repeatabily.
- c- Beam angle and alignment and statistical average of finite number of samples.

Due to the high frequency of the timer clock (250 MHz) ,uncertainty of measured signal of frequency 5 MHz is negligibly small. RMS of repeatabily for the long time applied measuring technique showed to be less than 0.5% increasing up to 2% in regions near walls. With accuracy up to 0.5 degrees in beam setting and error up to 3rd digit in measuring beam angle and for statistical average of samples of 1000 data ,the uncertainty is less than 0.5%. The total uncertainty is thus less than 1% and reaches 2.5% in regions near walls. The most significant systematic error is due to increased laboratory air temperature during such long time measurements. Shifting of probe volume from one measuring position to next one and sampling of 1000 data values at such low data rate take an average time of approximately 100 seconds. Thus measurements of one complete profile of 80 points lasts 2 hours in average. Estimates based on actual temperature increases show that maximum errors in percentage of measured velocity in case of C Shape duct is 2.75% and in the case of S shape duct is 3.9%. This error affects mainly the slope of velocity profile in the potential core ,whereas its effect on the boundary layer results is negligible due to the much shorter time taken in their measurements. Positiong accuracy of probe volume is ± 0.5 mm , mainly contributed to by the system (LDV and duct) vibrations.

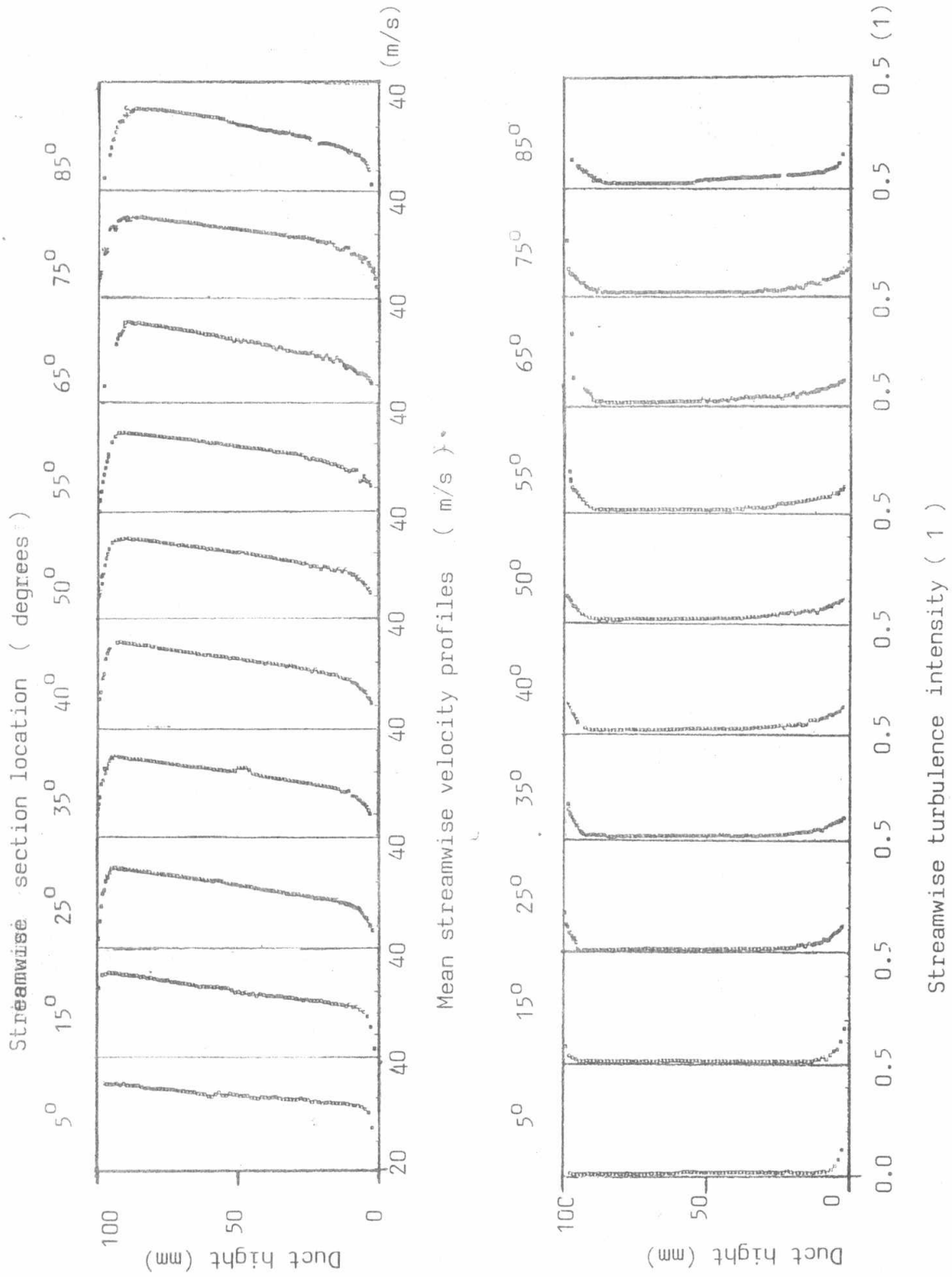

Fig.6. Profiles of mean streamwise velocity and turbulence intensity (C shape duct).

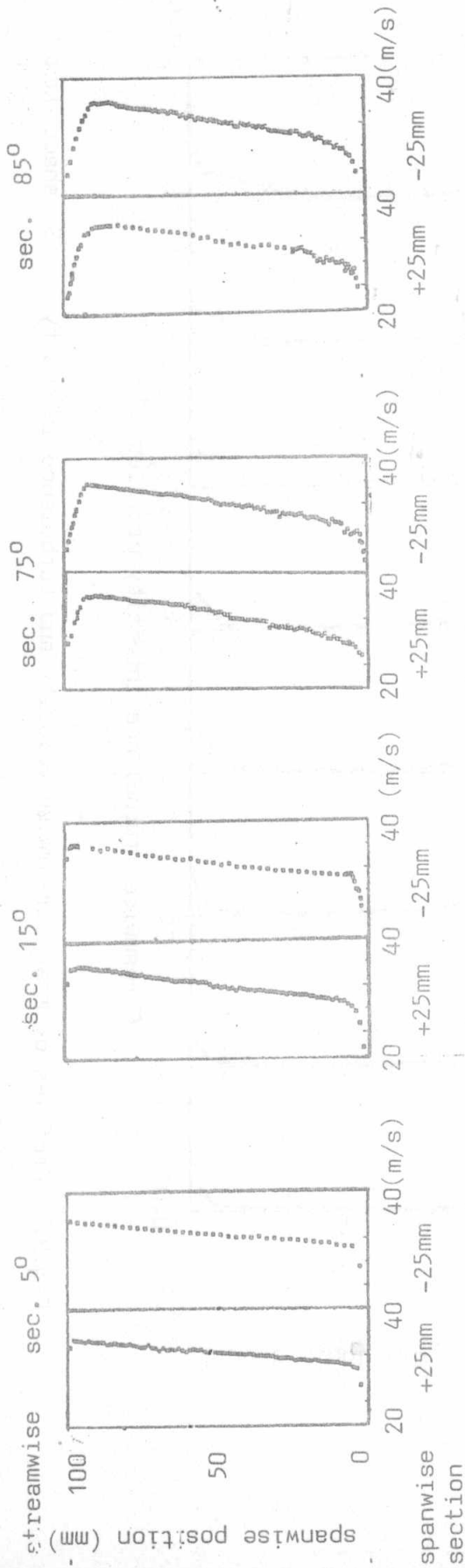

Fig.7. Mean streamwise velocity profiles at different spanwise sections. (C duct) .

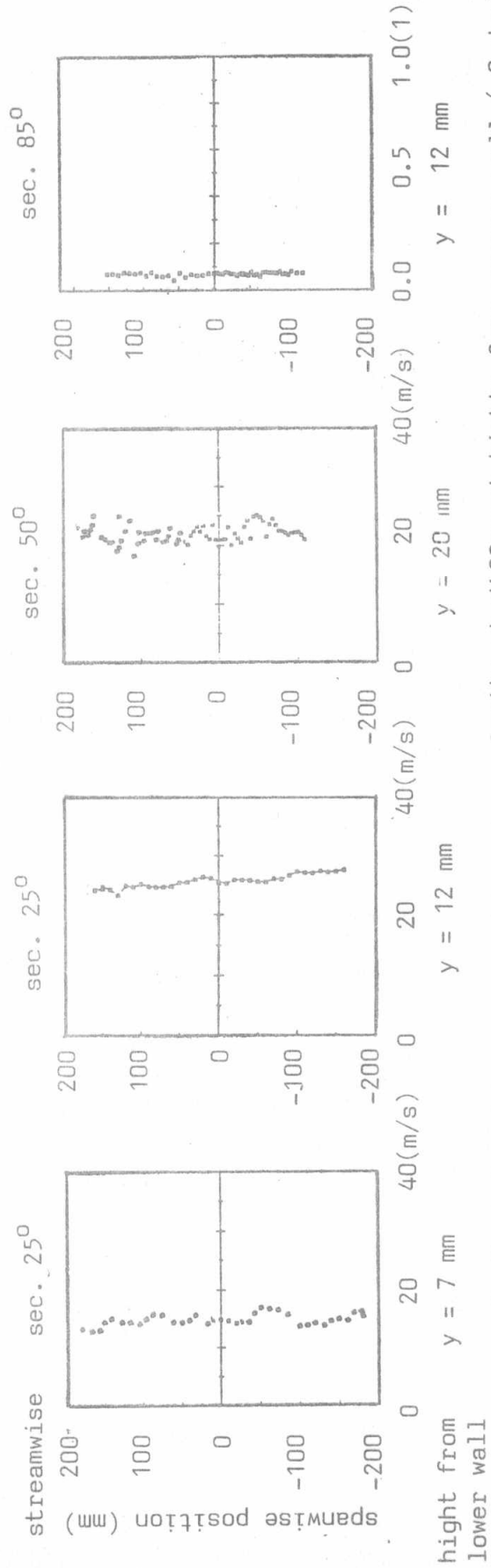

Fig.8. Lateral traverses of spanwise velocity at different heights from concave wall (C duct)

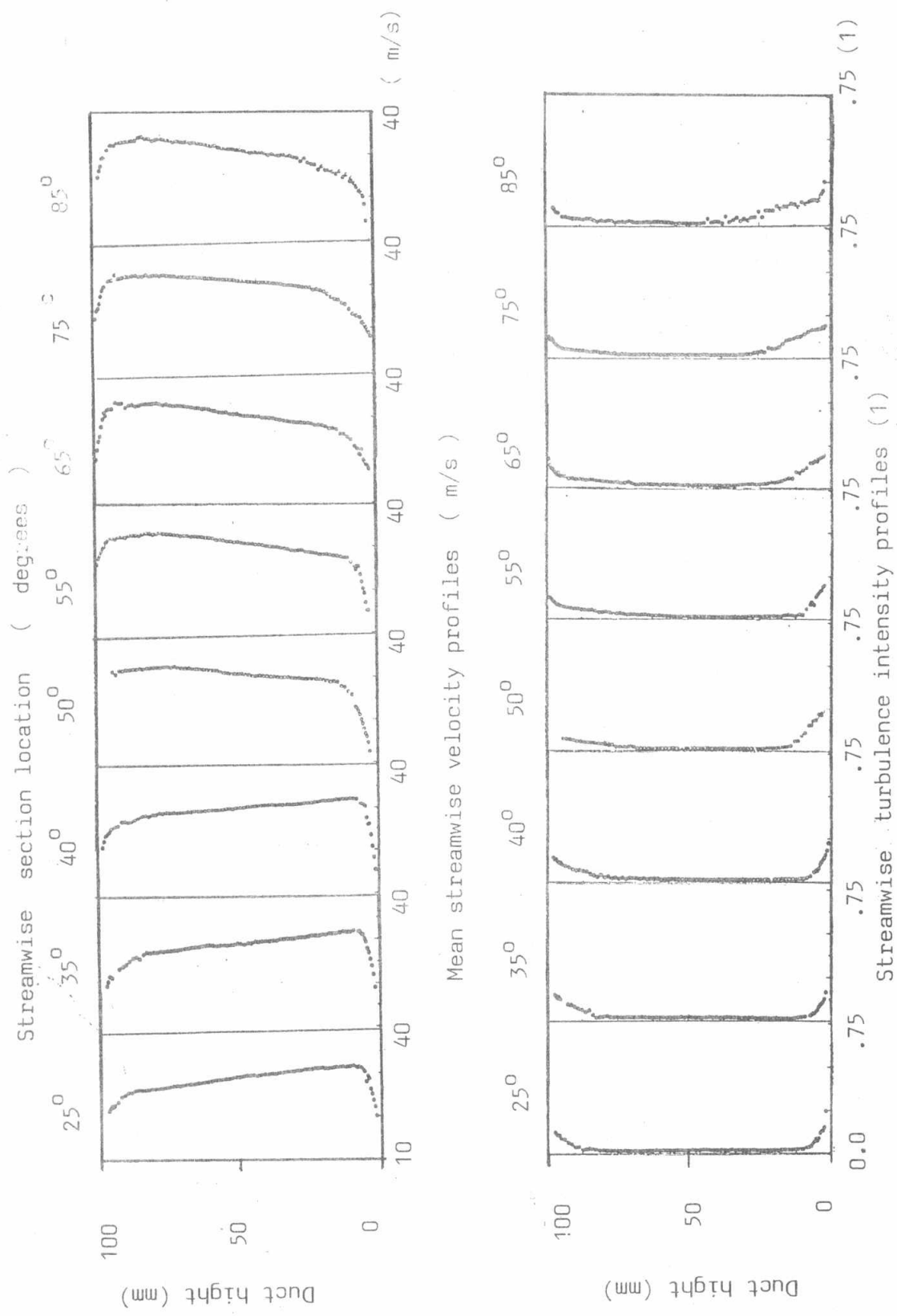

Fig.9. Profiles of mean streamwise velocity and turbulence intensity (S shape duct)

CONCLUSIONS

Streamwise measurements in the C shape duct show the effect of curvature on boundary layers of both convex and concave walls. Convex wall curvature resulted in a stabilizing effect on boundary layer along its surface with inhibition of its growth. Contrary, the concave wall showed destabilizing effect, accelerating boundary layer growth and increasing the spread of turbulence effects away from wall. Boundary layer thickness on concave wall is found to be three times higher than its value on convex wall for same flow conditions. Due to curvature effect, there is a velocity gradient in potential core across duct. With boundary layer growth, average velocity in potential core increases, which is in agreement with considerations of mass conservation. Velocity profiles measured on both sides of duct's plane of symmetry did not manifest significant differences. This is in agreement with assumptions of flow two dimensionality in such rectangular high aspect ratio ducts at moderate Reynolds numbers. Nevertheless, slight spanwise velocity variations are observed in boundary layer regions and its velocity traverses which may be attributed to not well defined unsteady Goertler vortex system.

REFERENCES

1. Sullivan, J.: Laser Doppler Velocimetry training course. Presented at NASA Lewis research center, Cleveland, Ohio USA, 1980.
2. Holt, M., Flores, J. and Turi, P.: Measurement of airflow in a curved pipe using LDV. International symposium on application application of Laser Doppler Anemometry to fluid mechanics. Lisbon, Spain 1982.
3. Crane, R. and Sabzvari, J.: Laser Doppler Measurements of Gortler vortices in laminar and low Reynolds number boundary layers. International symposium on application of Laser Doppler Anemometry to fluid mechanics. Lisbon, Spain 1982.
4. So, R. and Mellor, G.: Experiments on turbulent boundary layers on a concave wall. Aeronautical Quarterly 26, Feb 1975.
5. Anderson, B., Taylor, A., Whelan, J. and Yianneskis, M.: Developing flow in S shape ducts. International symposium on application of Laser Doppler Anemometry to fluid mechanics. Lisbon, Spain 1982.
6. Butz, L.: Turbulent flow in S-shaped duct. MSc thesis, Purdue university, Indiana, USA, 1979.
7. Flack, R. and Thompson, D.: The LDV's potential in understanding turbulent structures. School of Mechanical Engineering, Purdue university, Indiana USA.
8. Herbert, T.H.: On the stability of boundary layer along a curved wall. Archives of Mechanics 28, Warsaw, Poland 1976.
9. Sullivan, J., Murthy, S., Lan, T., Davis, R. and Hong, S.: S-shaped duct flows. Technical status report S-ONR-TSR-80-2. School of Aeronautics and Astronautics, Purdue university, Indiana, USA. October 1980.
11. Durst, F., Melling, A., Whitelaw J.: Principles and practice of Laser Doppler Anemometry. Academic press, 1981.
12. Thompson, H., Stevenson, W.: Laser velocimetry and particle sizing. Hemisphere publishing corporation, 1979.
13. Lorcher, G. and Grotzbach, G.: LDA measurements in turbulent incompressible flows used for verification of theoretical turbulence models. Proceedings of the LDA-symposium. Copenhagen, 1975.