



Torsion Behavior of Recycled Aggregates Concrete Beams With Openings

Yahia Mohy El-Deen Osman¹ Ashraf Adel Shawky², Hany Ahmed Abdalla^{3,*}

¹ M.Sc. Student -Structural Engineering Department, Faculty of Engineering, Cairo University,

² Associate Professor of Concrete Structures -Structural Engineering Department, Faculty of Engineering, Cairo University, Egypt

³ Professor of Concrete Structures -Structural Engineering Department, Faculty of Engineering, Cairo University, Egypt

ARTICLE INFO

Article history:

Received: 22-05-2022

Accepted: 12-09-2022

Online:12-09-2022

Keywords:

Recycled aggregate

RC Beams

Opening

Rotation angle

Torque

ABSTRACT

Due to the fast rise in material and transportation costs, the recycling of construction waste has become a critical operation in the construction industry. Therefore, the use of construction waste as coarse aggregate should be researched to ensure that the structural behavior of these structures does not differ from that of non-recycled (natural) coarse aggregate buildings (NCA). An experimental investigation was conducted in this study to explore the influence of recycled coarse aggregate (RCA) on reinforced concrete beams with opening and subjected to pure torsion. Six beams with identical cross-sectional dimensions of 150 x 350 mm and a total span of 1400 mm attached monolithically at the two ends by two cantilevers having 200 mm wide and 350 mm long are included in the investigation. The tested beams included two solid beams and four beams with 300 x 150 mm opening. The existence of opening and the ratio of RCA replacement were considered as the parameters in this investigation. From the results of this study, the crack patterns of RCA and NCA specimens were similar, and the increase of RCA replacement ratio led to a decrease in the cracking and ultimate capacities. The existence of an opening changed the failure mode from sudden torsional shear failure as in the reference specimen without opening to crushing of concrete and concrete cover separation. A comparison between the experimental outcomes, the ACI code, and the ECP-203 code was conducted, and showed a good agreement with the experimental results.

1. Introduction

Demolition of old and damaged buildings and traffic infrastructure, and replacement with new ones, is a common occurrence in many parts of the globe nowadays. Changes in purpose, structural degradation, city reorganization, expansion of traffic directions and increasing urban load, natural catastrophes (earthquake, fire, and flood), and other factors are all contributing to this condition. In the EU, for example, over 850 million tons of building and demolition trash are created each year, accounting for 31% of total waste output [1]. The most prevalent technique of dealing with this waste has been to dump it in landfills. Huge piles of building debris are created as a result, posing a unique challenge of human environmental contamination. As a result, recycling has become an essential process in the construction sector as a part of environmental concerns.

The torsional loading on a reinforced concrete (RC) beam can

be either equilibrium torsion, which occurs when considering the torsional moment as an important straining action to preserve the structural components from failure, or as a compatibility torsion, in which the torsional moment is reduced due to the redistribution of the internal forces while maintaining the compatibility of deformation. For example; an edge beam carrying a cantilever slab, and an edge beam carrying two beams which producing a torsional moment for equilibrium, and compatibility torsions, respectively. The torsional moment was applied on the investigated specimens through the previous researches by using the two most common test setups. The first way to apply the torsional moment is by installing a steel frame at the two ends, which performs as two transverse cantilever beams [2-5]. The second way is to cast the beam with two additional opposite RC cantilevers [6-9].

The cracking capacity is primarily depends on the ratio between the transverse and longitudinal reinforcement, in addition to the total quantity of torsional reinforcement [10].

* Hany Ahmed Abdalla, Structural Engineering Depart., Faculty of Engineering, Cairo University, Cairo, Egypt , +2 01005556065, drengany@gmail.com

When using high strength concrete (HSC) with transverse to longitudinal reinforcement ratio up to 27 %, a brittle failure is observed [10]. On the other hand, a ductile failure is observed when the ratio is increased up to 98 % when using normal strength concrete (NSC) and HSC [10]. For hollow beam sections, the cracking strength was smaller than those of the beams with solid sections in case of using low amount of torsional reinforcement [10]. By increasing the dimensions of the void in the hollow beams, the cracking and ultimate strengths are decreased [10]. The torsional stiffness and strength are increased with the increase of the transverse torsional reinforcement. Xin et al. [11] studied a composite section consisting of two steel channels positioned at the upper and lower layers of the beam and their web was parallel to the horizontal axis. After cracking, a sharp decrease in the torsional stiffness was observed [11]. The torsional behavior is influenced by the concrete strength, shape of stirrups, and the angle of steel lacing which connects the two channels [11].

When replacing the NCA with RCA, the load carrying capacity and the stiffness are decreased, while the deflection is increased in case of combined bending and torsional loading. The differences in values for the first crack and ultimate torque between RCA and NCA beams were less than 12.5 %, and 7.7 %, respectively [12]. RCA has more water absorption than NCA up to 1246% [13]. In the case of 100 % replacement with RCA, the modulus of elasticity achieved the lowest value of 18 % decrease compared with the NCA beam [12]. By increasing RCA, the torsional strength decreases, and the angle of twist increases. The torque-twist behavior and failure mode of RCA beams were similar to that of NCA beams [12- 14]. Due to the difference between the densities of RCA and NCA, the mix design require more amount of RCA [14].

For the flexural behavior of RCA beams, the crack pattern was similar to NCA beams, while the deflection is increased with the increase of the RCA replacement ratio [14]. For the compressive behavior of RCA columns, the crack pattern was similar to the column specimen with NCA [13]. The columns' ultimate capacity, stiffness, and maximum displacement were higher for RCA columns with 30 % and 50 % RCA replacement ratios compared with NCA columns, while the 100 % RCA replacement ratio recorded the lowest values [13]. For the shear behavior of beams with RCA without stirrups reinforcement, the crack pattern and failure mode had no major differences between RCA and NCA beams [15]. Generally, RCA beams had more ductile failure after diagonal cracking formation than NCA beams [15]. When decreasing the ratio between the beam shear span and the depth of the beam, the shear strength of RCA beams increases.

The bond behavior between RCA specimen and steel reinforcement has been investigated by Zhang [20b]. It was observed that the ratio of RCA replacement has a minor effect on the bond-slip curve and the failure mode, and by increasing RCA ratio, the bond strength decreases [16]. The bond strength can be improved by increasing the stirrups ratio and the thickness of concrete cover [16].

The existence of opening in the beams led to a decrease in the cracking and ultimate torque capacity by 45 % and 38 %, respectively with maintaining the same reinforcement [17 - 18]. The cracking and ultimate torsional capacities can be improved by placing horizontal reinforcement and stirrups above and below the opening [19]. Installing horizontal and vertical reinforcement bars around the opening had a better torsional performance than placing closed stirrups [19]. The existence of reinforcement around the opening led to preventing the cracks from spreading at the opening corners, and decreased crack propagation [19].

The main objective of this research is to experimentally investigate the torsional behavior of RC beams with NCA and RCA with and without opening. Three RCA replacement ratios were utilized in the beams of 30 %, 50 %, and 100 %. During the experimental work, the crack pattern, failure mechanism, failure load, torque-rotational angle relation, load-strain relation for longitudinal reinforcement, and toughness were recorded. Also, a comparative study between the experimental results, the ACI [20], and the ECP 203-18 [21] codes was conducted to help the structural engineer when choosing to use the RCA in RC beams with opening and subjected to torsional moment.

2. Experimental work

2.1. Test beams

The ratio of RCA and the existence of opening were the main studying parameters in this research. Six RC beams with the same cross section dimensions of (150 × 350) mm, test span of 1000 mm, and overall span of 1400 mm were tested. The specimens are Z-shaped with two opposite cantilevers with cross section of (200 × 350) mm, and span of 500 mm as shown in Figure 1. For all tested beams, the longitudinal reinforcement consisted of eight high tensile steel bars of 10 mm diameter, and the transversal reinforcement consisted of closed stirrups of 6 mm diameter with spacing of 150 mm as shown in Figure 2. According to the codes provisions [22], the depth of opening must not exceed the half of overall beam depth, and the length of opening is depending on the stability of compression chord, and the requirements of serviceability for the deflection. Table 1 shows the characteristics of all tested beams.

Table 1. Details of all tested beams

Group	Beam No.	Terminology	Opening configuration	Description
I	B1	CB-NO	No opening	Control beam without opening
	B2	CB-O	150x300 mm	Control beam with opening
II	B3	BO-30	150x300 mm	RC beam with 30% RCA
III	B4	BNO-50	No opening	RC beam with 50% RCA without opening
	B5	BO-50	150x300 mm	RC beam with 50% RCA with opening
IV	B6	BO-100	150x300 mm	RC beam with 100% RCA with opening

CB: control beam specimen; NO: without opening; O: with opening; (30, 50, and 100): Recycled Concrete Ratio; BNO: test beam without opening; BO: test beam with opening.

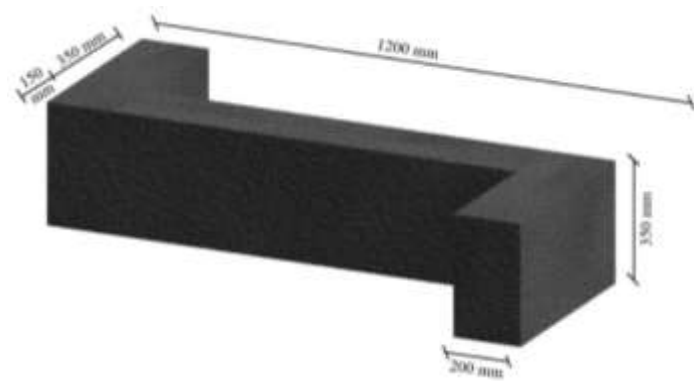

(a) Beam without opening

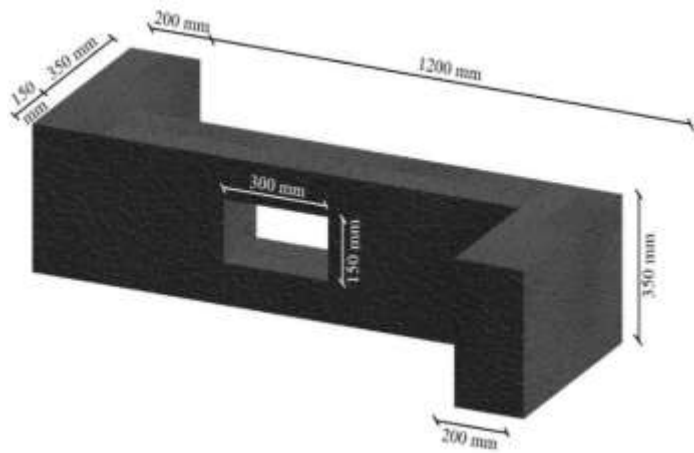

(b) Beam with opening

Figure 1. Concrete Dimensions of the tested RC beams.

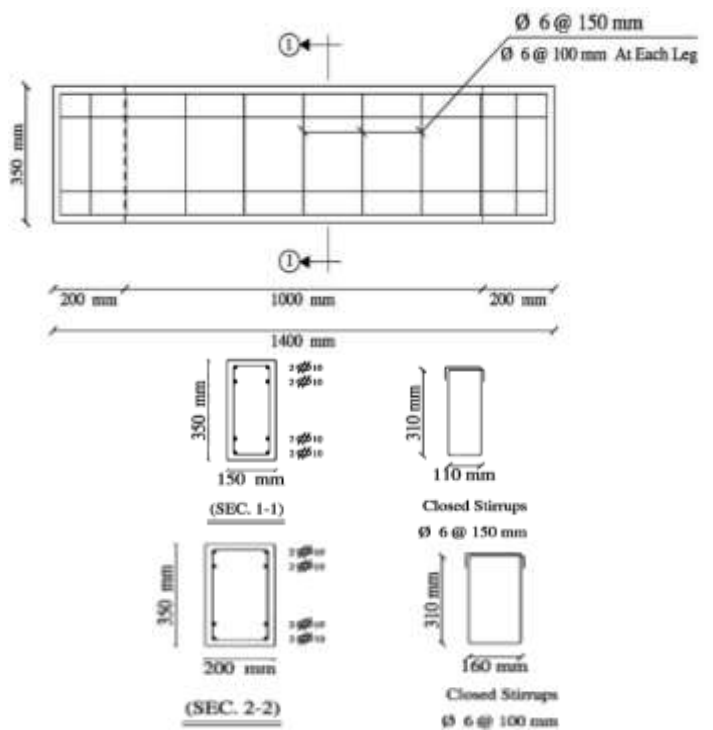

(a): Reinforcement Details of the Specimens without opening

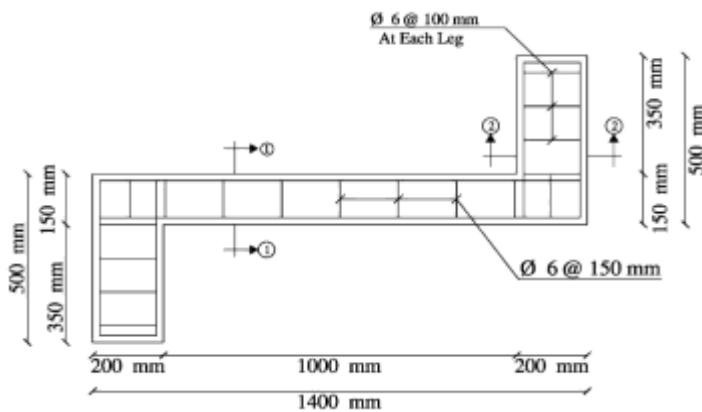
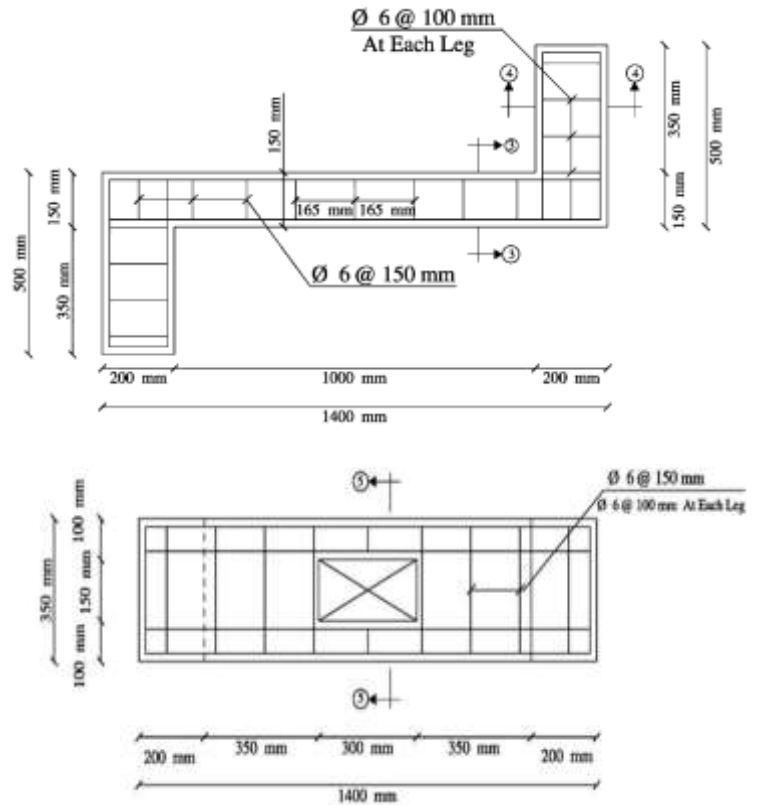

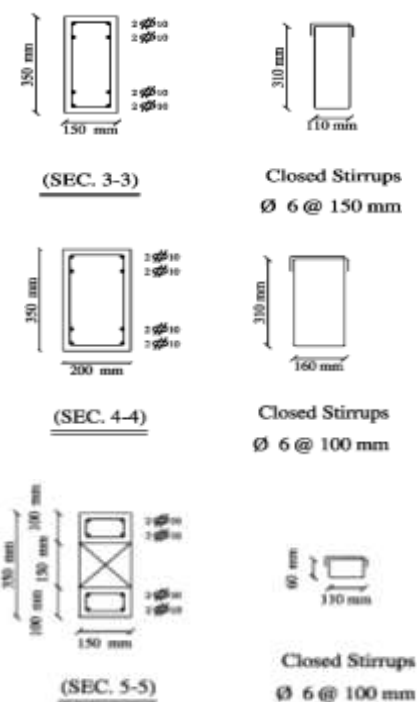

(b): Reinforcement Details of the Specimens with opening

Figure 2. Reinforcement Details of the Specimens.

2.1. Materials

Standard compression test cubes with dimensions of (150 × 150 × 150) mm and compressive strengths ranging between 25 and 30 MPa are the source of RCA in the current study. To create RCA, the concrete cubes have been manually crushed with a hammer weighted 0.5 kg. The crushing operation is repeated until the crushed particles' maximum size is less than 40 mm. Three sieves with sizes of 19 mm, 9.5 mm, and 4.75 mm are used to classify the crushed material. In all concrete mixtures, normal Portland cement with a grade of (N42.5) is used. A flexure test on a cement mortar specimen with dimensions of (40 × 40 × 160) mm is used to verify the compressive strength. A flexural force is applied to the test specimen until it breaks into two pieces. Then, until failure, each item is exposed to a compressive load. The RC beams are made out of two different steel bars diameters. A standard tensile test of steel bars has been conducted on the two utilized longitudinal and transverse steel bars types. The longitudinal steel bars were 10 mm in diameter and have an ultimate tensile strength of 520 MPa. Stirrup bars were 6 mm in diameter and have an ultimate tensile strength of 360 MPa. According to ECP 203-18 code [21], four distinct concrete mixes with various RCA ratios and compressive strengths of 25 MPa and 30 MPa are developed using the absolute volume technique, which requires the specific gravity for each constituent. Table 2 shows the proportions of each mix. For each mix, four cubes were poured and two of them are cured for seven days and the other two are cured for 28 days. All cubes were tested under the compression machine after curing to determine the failure load under compressive normal force. Table 3 shows the cubes compressive strengths results after 7 and 28 days

Table 2. The proportions of the utilized concrete mixes per 1 m3

Mix	Cement (kg)	Water (Liter)	Fine aggregate (kg)	RCA (kg)	NCA (kg)	RCA Ratio
Mix 1	400	240	562	0	1012	0%
Mix 2	400	240	553	332	664	30%
Mix 3	400	240	555	500	500	50%
Mix 4	400	240	548	987	0	100%

Table 3. The cubes compressive strengths results after 7 and 28 days

Groups	ID	Weight (kg)	fcu after 7 days (MPa)	Average fcu after 7 days (MPa)	Weight (kg)	fcu after 28 days (MPa)	Average fcu after 28 days (MPa)
Group A	Cu-REF	9.35	20.13	21.57	9.43	23.86	29.74
	Cu-REF	9.39	23.01		9.40	28.67	
Group B	Cu-30-I	9.46	22.49	20.32	9.48	33.18	28.41
	Cu-30-II	9.43	20.44		9.45	27.64	
Group C	Cu-50-I	9.10	19.02	19.98	9.13	24.33	28.33
	Cu-50-II	9.05	20.95		9.10	34.74	
Group D	Cu-100-I	9.37	19.37	19.20	9.40	22.86	24.97
	Cu-100-II	9.31	19.03		9.35	24.96	

2.2. Test Setup

The RC beams specimens were tested at the concrete research laboratory of Cairo University. As shown in Figure 3, movable supports were utilized to allow torsional loading on the specimens then the beams were lifted using the laboratory crane to be located under a hydraulic jack with capacity of 100 ton and rested on the movable supports, while maintaining an attached steel chains at the two ends of the beams with the crane for the stability till installing the other testing instruments and start the loading process. Before casting the beams, a strain gauges with dimensions of (6 × 2.2) mm and an electric resistance of 120 Ohm were installed on the steel reinforcement by smoothing the chosen area on the steel bars using grinder machine, then an adhesive material is applied to attach the strain gauges on the

steel bar. Three strain gauges were installed at the middle stirrup in case of solid beam and on the adjacent stirrup

next on the opening, the last stirrup in the beam, and on the bottom longitudinal bar at the mid span. Two LVDTs with 100 mm stroke were installed at the mid span of the cantilevers. The torque was calculated by multiplying the force by the horizontal arm between the loading point and the beam axis. To obtain the rotational angle, the average reading between the two LVDTs was calculated and divided by the distance from the LVDT to the beam axis.

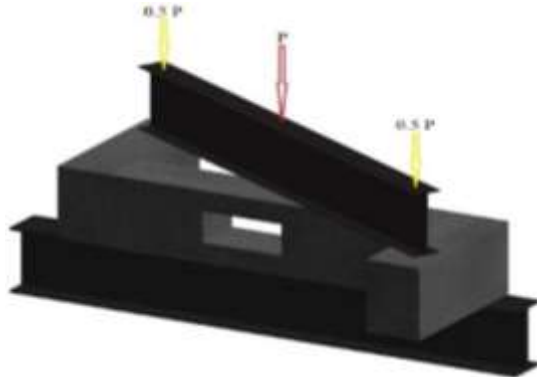

(a) Location of loads

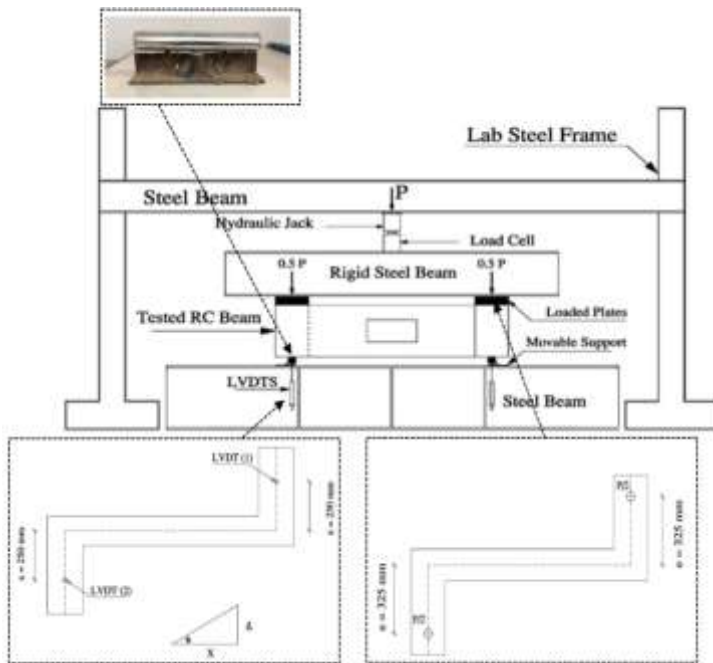

(b) Schematic test setup

Figure 3. Test setup for beam specimens

3. Results and Discussion

The experimental results are separated into two groups for examination and comparison. The first group investigates the effect of the RCA replacement ratio on the RC beam torsional

performance. The effect of the opening is studied in the second group. The control specimen (C-NO) failed due to a sudden torsional shear diagonal crack that developed at the ultimate torque, while the other beams (CB-O, BO-30, BNO-50, BO-50, and BO-100) had a separation of the concrete cover and crushing of concrete at the top and bottom chords of the opening. Figure 4 shows the crack propagation and mode of failure of the tested beams.



(a) CB-NO



(b) CB-O



(c) BO-30

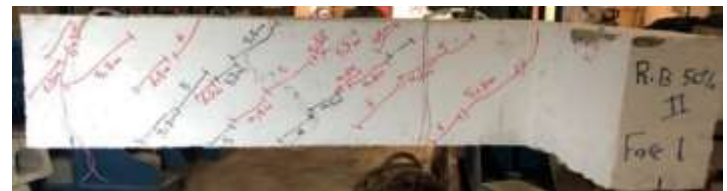

(d) BNO-50



(e) BO-50



(f) BO-100

Figure 4. Crack propagation and mode of failure of the beams.

3.1. Effect of changing RCA replacement ratio

The RCA ratio of 30% and 50% had a decrease in the cracking torque by 7.3%, and 18%, respectively. The largest decrease in the cracking torque was observed when using 100% RCA replacement ratio, recording a decrease up to 35.8% as shown in Figure 5-a. The specimen with RCA ratio of 30% had a minor decrease in the ultimate torque by 0.8%, while RCA ratios of 50% and 100% had a decrease by 7.4%, and 29.1%, respectively as shown in Figure 5-b. The RCA ratio of 100% had the lowest maximum rotational angle with a decrease of 41.7%, while the RCA ratios of 30% and 50% had a slight decrease by 2.2%, and 11.1%, respectively as shown in Figure 5-c and Figure 5-e. Except for the beam containing 100% RCA, the longitudinal steel bars of the specimens have extended and reached the yielding strain, but the transversal steel bars (stirrups) that were positioned next to the opening, had a plastic strain and the specimen collapsed before the transversal steel bars approached the yielding strain. As a consequence, two conclusions may be taken: first, longitudinal steel bars play an important role in torsional moment resistance, and second, the 100% recycled specimen collapsed due to concrete failure before the longitudinal and transversal steel bars reached yielding strain. To calculate the absorbed energy by the beam (toughness), the area under torque rotational angle was integrated. The toughness of the specimens with 30% and 50% RCA ratio had a similar toughness as in the control specimen with a slight decrease by 3%, and 15%, respectively, while the beam with RCA ratio of 100% had the highest decrease in toughness by 58.8% as shown in Figure 5-d.

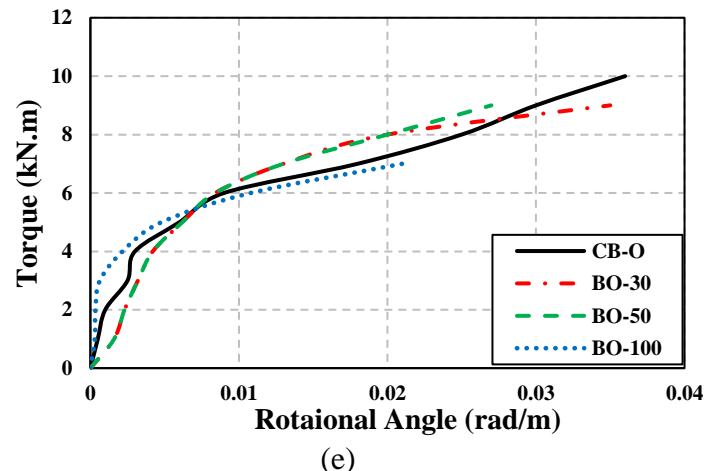
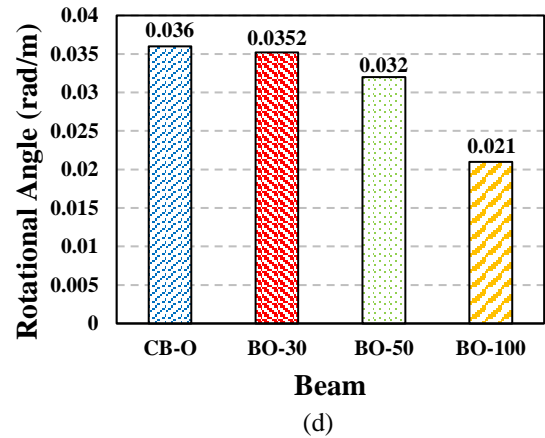
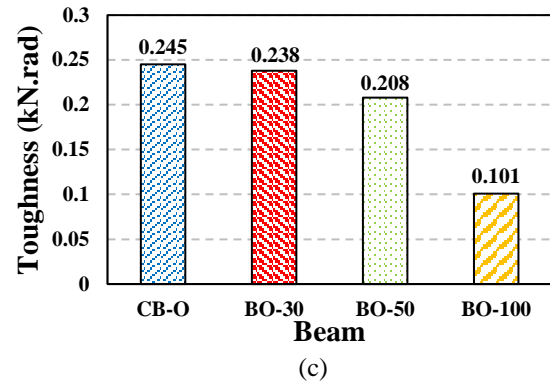
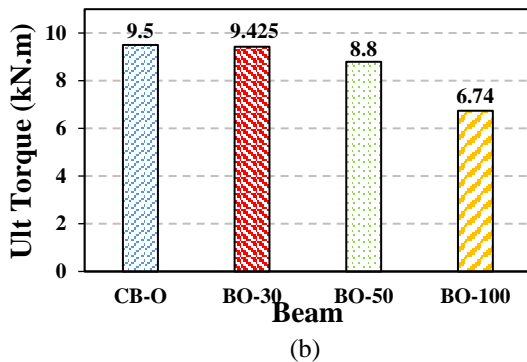
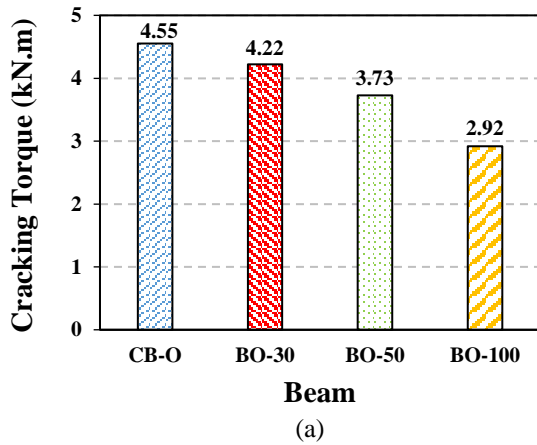

Figure 5 The effect of changing RCA ratio on beam specimens with opening.

The influence of the presence of RCA is shown in Table 4. It was observed that by increasing RCA replacement ratio, the torsional performance is decreased till reaching the maximum deduction when using 100% RCA replacement ratio. The best performance of RCA specimens was achieved when using 30% RCA ratio with a minor decrease in the overall performance.

Table 4. Summary of the test results

Beam	P_{max} (kN)	T_{cr} (kN.m)	T_{ult} (kN.m)	θ_{ult} (rad)	Toughness
CB-O	58.7	4.55	9.5	0.036	0.245
BO-30	58	4.22	9.42	0.0352	0.238
BO-50	54.5	3.73	8.8	0.032	0.208
BO-100	41.5	2.92	6.74	0.021	0.101

P_{max} : Maximum applied load; T_{cr} : Cracking torque; T_{ult} : Ultimate applied torque.

3.2. Effect of Opening existence

The results of the control specimens with and without opening (CB-NO, and CB-O) were compared with the beams that contain RCA ratio of 50% with and without opening (BNO-50, and BO-50) as observed in Figure 6. To study the effect of opening existence only, two sets of comparisons were made. The first set is to compare the results of beams CB-NO and CB-O together, and the second set is to compare the results of beams BO-50 and BNO-50 together. The control beam with opening (CB-O) had a decrease in the cracking torque, ultimate torque, maximum rotational angle, and toughness by 38%, 27.5%, 35.7%, and 58.5%, respectively, compared with the control beam without opening (CB-NO). For the second set, the 50% RCA beam with opening (BO-50) had a decrease also in the cracking torque, ultimate torque, maximum rotational angle, and toughness by 47.2%, 16.7%, 20%, and 37%, respectively, compared with the 50% RCA beam without opening (BNO-50). To investigate the effect of RCA only with the existence of opening, the results of beams CB-O and BO-50 were compared. The beam BO-50 had a decrease in the cracking torque, ultimate torque, maximum rotational angle, and toughness by 18%, 7.4%, 11.1%, and 15%, respectively.

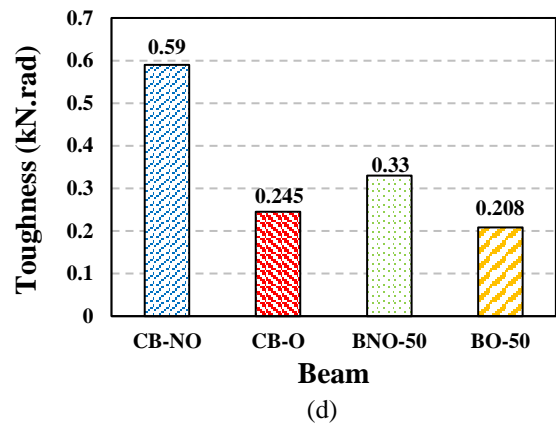
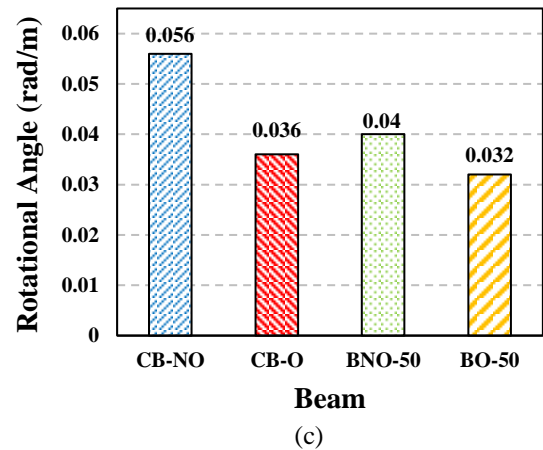
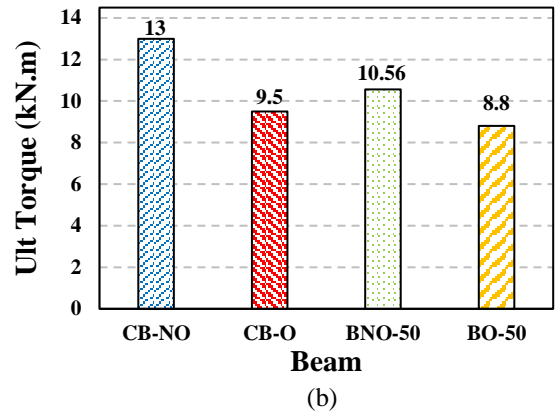
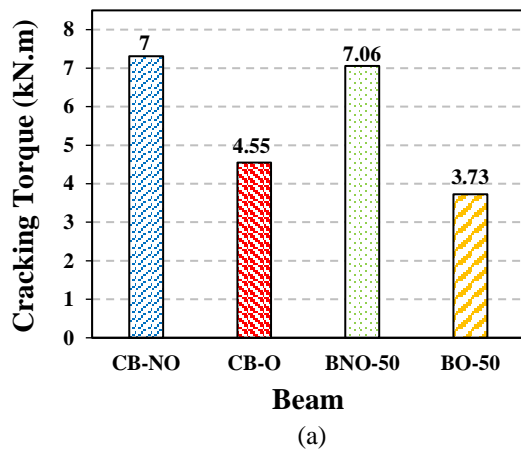

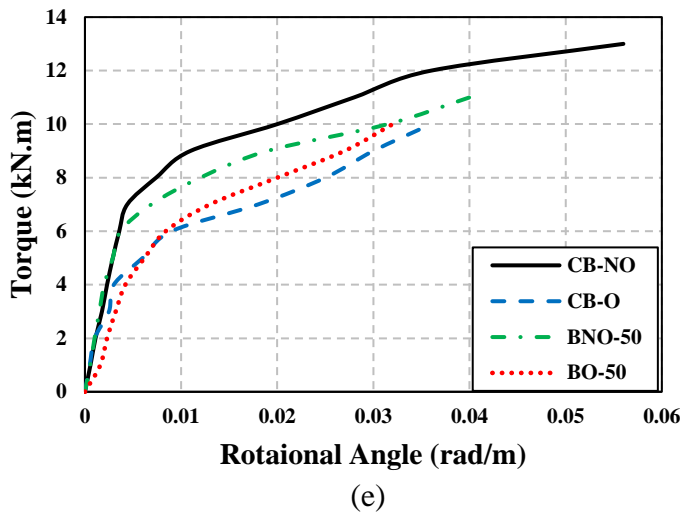

Figure 6. The effect of opening existence.

3.3. Comparison between experimental results, ACI code, Egyptian code

The design formulas in the ACI [20] and ECP 203-18 [21] codes are similar, and the max design torsional moment for beams subjected to torsional moment can be calculated as following:

$$M_{tu} = \frac{A_{str} \times 2A_o \times f_{yst} / \gamma_s}{s} \quad (1) [20, 21]$$

Where, M_{tu} is the maximum design torsional moment, A_{str} is the area of the closed stirrups for one branch, A_o is the area enclosed by the path of shear flow ($A_o = 0.85 \times A_{oh}$), A_{oh} is the gross area enclosed by the outer most closed stirrups centerline, f_{yst} is the yield stress of the stirrups, γ_s is the reduction factor of steel (let $\gamma_s = 1$), and s is the spacing between stirrups. Table 5 shows the calculated values of the formula parameters. From Table 6, it was observed that the calculated design ultimate torsional moments from the codes formula were more conservative than the achieved experimental results. Also, the calculated torsional moments were less than all observed cracking torque by 64%, 67%, 64%, 63%, 59%, and 48% for beams CB-NO, CB-O, BO-30, BNO-50, BO-50, and BO-100, respectively, which indicates that the design codes values aim to prevent the premature cracking due to torsion by applying a reduction on the actual strength of approximately 64%.

Table 5. The calculated parameters and torsional moment from the design torsion eq.

Existence of opening	A_{str} (mm ²)	A_{oh} (mm ²)	A_o (mm ²)	f_{yst} (N/mm ²)	s (mm)	M_{tu} (kN.m)
Without opening	28.26	34,100	28,385	240	150	2.62
With opening	28.26	13,200	11,220	240	100	1.52

Table 6. Comparison between the experimental, and calculated torque from the ACI and the Egyptian Codes.

Beam	CB-NO	CB-O	BO-30	BNO-50	BO-50	BO-100
M_{tu} (Formula) (kN.m)	2.62	1.52	1.52	2.62	1.52	1.52
T_{cr} (Experimental) (kN.m)	7.31	4.55	4.22	7.06	3.73	2.92
T_{ult} (Experimental) (kN.m)	13.00	9.50	9.42	10.50	8.80	6.74

4. Conclusions

In this paper, six RC beams were tested till failure to investigate the effect of RCA when changing the replacement ratio with and without the existence of web opening. Based on the experimental results, the following conclusions can be made:

1. The overall performance of beams with RCA in failure load, cracking and ultimate torques, maximum strain, and maximum rotational angle were better than those in RCA beams. The RCA replacements ratios of 30%, and 50% gave similar results to the beams with NCA with a slight decrease which encourages engineers in deciding when to use RCA in beams subjected to torsional moment from the economical and environmental aspects.
2. The failure mode and crack pattern for all specimens of NCA and RCA with opening were similar with no major differences. The failure mode was a separation of the concrete cover and crushing of concrete at the top and bottom chords of the opening.
3. The RCA replacement ratio of 100% achieved the lowest values in the cracking torque, ultimate torque, maximum rotational angle, and toughness by 35.8%, 29.1%, 41.7%, and 58.8%, respectively. The specimen with 100% RCA had more decrease than the beam with 50% RCA ratios by 2 times in the cracking torque, 3.9 times in the ultimate torque, 3.8 times in the maximum rotational angle, and 3.9 times in the toughness. On the other hand, the replacement ratio of 30% gave an acceptable differences compared with NCA beam by 7.3%, 7.4%, 2.2%, and 3% in the cracking torque, ultimate torque, maximum rotational angle, and toughness, respectively.
4. The existence of opening decreased the cracking torque, ultimate torque, maximum rotational angle, and toughness by 38%, 27.5%, 35.7%, and 58%, respectively for beams with NCA only, and decreased the behaviors of beams with 50% RCA replacement ratio by 47.2%, 16.7%, 20%, and 37%, respectively. From existence was observed in the case of NCA and RCA beams. The decrease in the cracking torque was 1.24 times the decrease in control specimens due to the existence of opening. The decreases in the case of 50%

RCA ratio were less than the decrease in the case of NCA beams due to the relatively low ultimate torque, maximum rotational angle, and toughness for beams with 50% RCA compared with the control specimen.

5. The design equations for estimating torsional moment are conservative when compared to the experimental results, which makes the structures safe and capable of resisting torsional moment. The calculated torsional moments from the ACI and the Egyptian codes were less than all observed cracking torque by 64%, 67%, 64%, 63%, 59%, and 48% for beams CB-NO, CB-O, BO-30, BNO-50, BO-50, and BO-100, respectively, which indicates that the design codes values aim to prevent the premature cracking due to torsion by applying a reduction on the actual strength of approximately 64%.

It's suggested for further studies to justify different loading conditions for combined shear, torsion and moments. Also it's recommended to investigate the effect of adding fibers to the RCA concrete, and to justify the most proper location of openings in the beams subjected to torsion.

Conflict of Interest

The authors declare no conflict of interest.

References

- [1] Fisher, C.; Werge, M. EU as a Recycling Society; ETC/SCP Working Paper 2/2009, (2009). Available at: <http://webdog.brbs.nl/files/EU-as-recycling-society-CDW.pdf> (accessed 2 April 2022)
- [2] Kandekar, S.B., Talikoti, R.S. Study of torsional behavior of reinforced concrete beams strengthened with aramid fiber strips. *Int. J Adv. Struct. Eng.* 10 (2018) 465–474. <https://doi.org/10.1007/s40091-018-0208-y>
- [3] Askandar N, and Mahmood A. Comparative Investigation on Torsional Behaviour of RC Beam Strengthened with CFRP Fabric Wrapping and Near-Surface Mounted (NSM) Steel Bar. *Adv Civ Eng.* 1-15, 2019. <https://doi.org/10.1155/2019/9061703>.
- [4] Kim M-J, Kim H-G, Lee Y-J, Kim D-H, Lee J-Y, and Kim K-H. Pure torsional behavior of RC beams in relation to the amount of torsional reinforcement and cross-sectional properties. *Constr Build Mater* 20, 2020. <https://doi.org/10.1016/j.conbuildmat.2020.119801>
- [5] Askandar NH, Mahmood AD, and Kurda R. Behaviour of RC beams strengthened with FRP strips under combined action of torsion and bending, *European Eur J Environ Civ Eng* 1-17, 2020. DOI:10.1080/19648189.2020.1847690
- [6] Salama AE, Kassem ME, and Mahmoud AA. Torsional behavior of T-shaped reinforced concrete beams with large web openings. *J Build Eng* 18, 84-94, 2018. <https://doi.org/10.1016/j.job.2018.02.004>
- [7] Abdo T, Mabrouk R. Effect of web openings on the structural behavior of RC beams subjected to pure torsion. *MATEC Web Conf* 120, 2017, 01007. <https://doi.org/10.1051/mateconf/201712001007>
- [8] Kumar GS. Experimental study on RC beams with recycled concrete as aggregate under combined bending and torsion. *Int J Appl Eng Res* 10 (13), 2015, 33262-33268.
- [9] Shalaby AR, Diaa G, Abdalla H. Repair of RC beams with openings subjected to torsion using steel plates. *IJCIET* 11 (10), 58-73, 2020. <https://doi.org/10.34218/IJCIET.11.10.2020.007>
- [10] Chiu H J, Fang IK, Young WT, and Shiau JK. Behavior of reinforced concrete beams with minimum torsional reinforcement. *Eng Struct* 29 (9), 2193-2205, 2007. DOI:10.1016/j.engstruct.2006.11.004
- [11] Xin Z, Jianyang X, Rui R, and Linlin M. Test on pure torsion behavior of channel steel reinforced concrete beams. *J Build Eng* 44, 2021, 102967. <https://doi.org/10.1016/j.job.2021.102967>
- [12] Sarsam KF, Salih N, and Hussein M. Assessment of reinforced recycling aggregate concrete beams under torsional moment. *Int J Eng Technol* 7 (4) 623-628, 2018. DOI:10.14419/ijet.v7i4.20.27403
- [13] Elansary AA, Ashmawy MM, and Abdalla HA. Effect of recycled coarse aggregate on physical and mechanical properties of concrete. *Adv Struct Eng* 24 (3) 583-595, 2021. DOI: 10.1177/1369433220963792
- [14] Deresa ST, Xu J, Demartino C, Heo Y, Li Z, and Xiao Y. A review of experimental results on structural performance of reinforced recycled aggregate concrete beams and columns. *Adv Struct Eng* 23 (15), 3351-3369, 2020. DOI: 10.1177/1369433220934564
- [15] Fathifazl G, Razaqpur AG, Isgor OB, Abbas A, Fournier B, and Foo S. Shear strength of reinforced recycled concrete beams without stirrups. *Mag Concr Res* 61 (7) 477-490, 2009. DOI: 10.1680/mac.2008.61.7.477
- [16] Zhang J, Tao X, Li X, Zhang Y, and Liu Y. Analytical and experimental investigation of the bond behavior of confined high-strength recycled aggregate concrete. *Constr Build Mater* 315, 2022, 125636. <https://doi.org/10.1016/j.conbuildmat.2021.125636>
- [17] Fawzy K, Hashem MM, and Elnady AM. Performance of RC beams with web opening subjected to pure torsion strengthened with CFRP. *IJEIT* 4(1) 197-204, 2014.
- [18] Makhlof MH. Torsional Behavior of RC Beams with Opening Using (CFRP-GFRP-Steel) Stirrups. *Adv in Res* 8 (3), 1-10, 2016. DOI: 10.9734/AIR/2016/30247
- [19] Abdel-kareem AH, and Abd El Salam, AM Experimental and Analytical Investigation of Reinforced Concrete Beams with Large Web Opening under Pure Torsion. *IJAEMS* 6 (1), 18-33, 2020. <https://dx.doi.org/10.22161/ijaems.61.4>
- [20] ACI Committee 318 Building code requirements for structural concrete and commentary, (ACI 318-14/ACI 318R-14). American Concrete Institute, Farmington Hills, MI, 2014.
- [21] Housing and Building Research Center Egyptian Code for Design and Construction of Reinforced Concrete Structures. (ECP203-2018). Ministry of Development. New Communities, 2018.
- [22] Pertiwi D, Komara I, and Fristian R. Design concept of reinforced concrete beams with large web openings. *InIOP Conference Series: Materials Science and Engineering*, IOP Publishing, (Vol. 1010, No. 1, p. 012039), 2021.