

THE EFFECT OF UNCONVENTIONAL SILLS TO DISSIPATE ENERGY DOWNSTREAM HYDRAULIC STRUCTURES

Rani F. Mohamed.¹ and Samah H. Abd El Ghany²

¹ Irrigation and Hydraulics Faculty of Engineering, Al-Azhar University, Egypt.

² 10th of Ramadan Higher Technological institute, Irrigation and Hydraulics. Civil Engineering Department, 10th of Ramadan city, Egypt.

* Corresponding: samasarah@yahoo.co.uk.

Received: 2 November 2021 Accepted: 29 July 2022

ABSTRACT

Water Kinetic energy downstream the hydraulic structures must be dissipated so as to stop severe scouring downstream apron and the failure of hydraulic structures. The shut block and sills with different forms are employed to disturb water and dissipate great amount of water energy through formation of a hydraulic jump in the stilling basin.

Engineers have designed and used many alternative kinds of energy dissipators in order to shield hydraulic structures against scouring. The most task of the hydraulic designers is a way to dissipate a major part of water energy behind the vertical/radial gates by using more practical tools.

The aim of this study is to get a better place to put the non-traditional sills to dissipate the resulting energy behind the vertical control gates. The hydraulic installations resulting from high speeds and different flows, which result in the occurrence of scour and erosion of the waterway behind these structures. The authors install a sill in several unconventional forms and study the efficient in dissipating kinetic energy. downstream hydraulic structures by installing it on relative dimensions of the gate L_b / L_f . Where L_f is that the length of the floor, L_b , distance from the gate, this was achieved to see the simplest position of the sill, aiming to reach the most energy dissipation and also the minimum length for the hydraulic jump.

Experimental study has been conducted in glassed wall flume with square cross section of (30 cm x 30 cm) and length of 4.00 m with transparent vertical sides, located in hydraulic lab - Faculty of Engineering - Al-Azhar University in Cairo, levels and water depths are measured. As well as the levels and depths of scour within the channel sector. The effect of the sill on different positions was investigated and also the results were discussed.

It was found that the best place to install the sill to dissipate the energy within the middle length of the floor and also the most effective ratio is (L_b / L_f) = 0. 50.

KEYWORDS: Energy Dissipations, Non-traditional sills, Scour, Hydraulic Structures, Hydraulic jump

تأثير العتبات غير التقليدية على تبديد الطاقة خلف المنشآت الهيدروليكية

راني فؤاد محمد^١ ، سماح حسن محمود^٢ *

^١ قسم هندسة الري والهيدروليكا، كلية الهندسة، جامعة الأزهر، القاهرة، مصر

^٢ قسم هندسة الري والهيدروليكا - قسم الهندسة المدنية - المعهد التكنولوجي العالي - العاشر من رمضان - مصر

* البريد الإلكتروني للباحث الرئيسي: samasarah@yahoo.co.uk

المخلص

تبديد طاقة الحركة للمياه خلف المنشآت الهيدروليكية من أجل منع النحر الشديد للتربة الرخوة المكونة لقاع قنوات الري من الأمور التي يجب الإهتمام بها لذا يتم استخدام البلوكات والأعتاب ذات الأشكال المختلفة لتكوين أحواض التهدئة لتبديد طاقة المياه المتبقية بعد القفزة الهيدروليكية وذلك من أجل حماية القنوات الهيدروليكية من النحر. ولقد صمم المهندسون العديد من الأنواع المختلفة من مبددات الطاقة. و تتمثل المهمة الرئيسية في كيفية تبديد جزء كبير من الطاقة المائية خلف البوابات الرأسية باستخدام مبددات أكثر فاعلية. و الهدف من هذه البحث هو دراسة نوع من الأعتاب الغير تقليدية وذلك كمبدد للطاقة المتبقية من القفزة الهيدروليكية خلف بوابات التحكم الرأسية وكذلك تغيير خصائص القفزة بالمنشآت الهيدروليكية للحصول علي طول فرشته مناسب وإقتصادي. و علي ذلك فقد تم عمل عتب غير تقليدية علي شكل ربع دائرة في المسقط الرأسي ونصف دائرة في المسقط الأفقي (شكل Q) ودراسة الكفاءة في تبديد الطاقة خلف المنشآت من خلال وضعها علي بعد نسبي من البوابة L_b/L_f . حيث L_f هو طول الفرشه، L_b المسافة من البوابة، تم تحقيق ذلك لرؤية أفضل موضع للعتبة و للوصول إلى أقصى قدر من تبديد الطاقة وأيضاً الحد الأدنى لطول القفزة الهيدروليكية. وقد أجريت التجارب علي قناة مربعة بمقطع (30×30 سم) بطول 4 أمتار ذات جوانب رأسية شفافة بمعمل الري والهيدروليكا كلية الهندسة جامعة الأزهر بالقاهرة، وقد تم قياس مناسب المياه وأعماقها وكذلك مستويات وأعماق النحر في قطاع القناة و تم إختبار المسافة النسبية ($0.25, 0.75, 1.00, 0.50$). وجد أن أفضل مكان لوضع العتب لتبديد الطاقة يكون في منتصف طول الفرشه. وأيضاً النسبة الأكثر فاعلية هي $(L_b / L_f) = 0.50$.

الكلمات المفتاحية: تشتيت الطاقة، الاعتاب غير التقليديه، النحر، المنشآت الهيدروليكية، القفزة الهيدروليكية

1. INTRODUCTION

Hydraulic jump is taken into account as an efficient tool for energy dissipation. Sills and baffles are used to stilling basin to extend the energy dissipation efficiency, in order to stabilize the hydraulic jump.

Many studies were conducted to think about the factors that affect these structures, the large energy that are generated downstream these structures, where a part of this energy rushes towards the run capable of destroying this property. This necessitates the construction of long apron to dissipate this energy.

McCorquodale and Khalifa [1] explore the characteristics of submerged hydraulic jump in a very radial basin experimentally and theoretically.

Experimental investigation to check the effect of location and length of roughened beds on flow characteristics meted out by Abouel Atta, Nahla [2].

Hassn et al. [1986] investigated the local scour downstream of the hydraulic structures. A sill is used at the end of the apron to manage and increases the jump stability and consequently reduce the construction cost [3]. Numerous varieties of stilling basins are currently used and available in literature Hager, W.H. [4].

Aziz F. E. et.al. [5] perform experimental work to check the effect of curved sill blocks having different sizes curvatures and arrangements in energy dissipation. They concluded that curved blocks when comparing with regular straight blocks have indicated that and for all flow conditions, the curved blocks are more practical in dissipating the excessive Kinetic Energy of the flow. Additionally, better stability to the hydraulic jump provided by the curved blocks.

El- Masry [6] studied the use of baffle blocks to dissipate the energy under a sluice gate. Two arrangements were considered. Baffles height, flow discharge, and downstream water depth were the considered variables. The results were compared with other investigators' results for one and double line of angle baffles.

The main task of the hydraulic designers is a way to dissipate a main part of water energy behind the vertical gate by using more practical tools. In 2003, Shri Ram Chaurasia stated that a lot of problems within the design of stilling basins require knowledge of assorted elements of a hydraulic jump with known values like discharge intensity and therefore the energy loss. Double line of angle baffles and fully angle baffled floor with angle blocks were detected [7].

Saleh et al [8] studied the scour characteristics of end sill downstream expanding stilling basins. The main characteristic of a hydraulic jump is the sudden transition of rapid shallow flow to slow moving flow with rise of the fluid surface also known as a transition from supercritical to subcritical flow [9]. The big length of hydraulic jump resulting from the rapid velocity causes bed scour in behind of these structures. This scour is one of the major challenges that threat the stability of the hydraulic control-structures. So the apron must be long enough to dissipate this energy, as well as acts of erosion behind this structure. Scientific and engineering investigation in hydraulic jumps has been conducted by laboratory, theoretically and numerically Methods over the past several decade due to its great energy and harm impact on the erodible channel.

A series of measurements to determine the length of the hydraulic jump was made by the U.S. Bureau of reclamation. In these experiments, Froude number varies from two to twenty. An analysis of the experimental data indicated that a good relationship between the length and the height of the hydraulic jump existed showing that the length of the jump is 6.9 times the jump height. Experimental study of the air-water shear flow in a hydraulic jump had been carried out by Chanson and Brattberg [10].

Mostafa Ali [11] studied the effect of aprons of formed surfaces as energy dissipators downstream hydraulic structures. Ashour [12] suggested using curved sill to control and dissipate the energy of water behind the vertical gates. Ali et al. [13] investigated flow characteristics downstream the radial gate of the New Naga Hammadi Barrages.

Abdelazim et al. [14] studied experimentally the effect of different shapes of stilling basin on the length of the submerged hydraulic jump, velocity profile, and local scour Downstream the hydraulic structure.

Hana Abdelhaleem [15] studied optimum design of staggered concrete blocks downstream of regulators. She searched about a suitable basin downstream multi vent regulators to dissipate energies through formed hydraulic jump. She studied flow characteristics under the effect of end sill with different heights, and baffles blocks with different heights and positions. It was found that the optimum location of the baffles is 30% and 50% of the basin length . Lagrangian mesh-free method Smoothed Particle Hydrodynamics (SPH) has been applied by Federico et al. [16] to simulate two-dimensional free-surface channel flows.

Jonsson et al. [17] investigated two-dimensional hydraulic jumps in horizontal open channel numerically by using Smoothed Particle Hydrodynamics (SPH) modeling.

Edward [18] presents a statistical submerged solution of the hydraulic jump with sluice gate effects. Habibzadeh et al. [19] studied the effect of baffle walls and blocks on submerged jump characteristics.

Sill and baffle blocks over stilling basin were investigated. Experimental demonstration of a new extension plate scour countermeasure downstream of stilling basins by Barlock R, et al. [20]

This research was initiated with the objective of dissipating a major part of water energy behind the vertical gate by using non-traditional sills and more effective tools.

In this study, the best position, to put the non-traditional sill behind the structures were a proposed model is a sill in the form of a quarter of a circle in elevation and half circle in plan (Q shape) were examined as a non-traditional sill. The experimental study was conducted in a glass flume of length of 4 m. Relative length of apron ($L_b / L_f = 1.00, 0.75, 0.50, 0.25$) were examined. It was found that the best position to put the sill for the power dissipation is in the middle length of the apron and the best ratio is $(L_b / L_f) = 0.5$. Many records of water levels and depths as well as scour length and depth are analyzed and discussed.

This paper presents the stages of work that have been implemented to achieve the goal. These stages are as follows:

- Reviewing the literature
- A theoretical approach
- An experimental study
- Analyzing and discussing the results
- Conclusions and recommendations.

2. THEORETICAL APPROACH

A theoretical study was conducted using dimension analysis technique to get the relation between the various parameters, and variables for interaction between Q-shape sill and hydraulic jump behind the vertical gate. All parameter and geometry are defined in **figure(1-a &1-b)**.

The relationships are obtained between Froude number (Fr) and relative lengths of the hydraulic jump (L_j / L_{jw}), Froude number (Fr) and the relative scour depth (D_s / D_{sw}) as well as the relative scour length and the relative scour depth (L_s / L_{sw}) to Froude number (Fr) with the relative height sill (y_n / r).

Where:

- L_j Length of hydraulic jump with Q-shape sill as energy dissipater.
- L_{jw} Length of hydraulic jump without energy dissipater.
- D_s Maximum scour depth with Y-shape sill as energy dissipater.
- D_{sw} Maximum scour depth without energy dissipater.
- L_s Maximum scour length with Y-shape sill as energy dissipater.
- L_{sw} Maximum scour length without energy dissipater.

THE EFFECT OF UNCONVENTIONAL SILLS TO DISSIPATE ENERGY DOWNSTREAM HYDRAULIC STRUCTURES

y_n Tail water depth.
 r Height of sill.

Depths upstream and downstream the jump are denoted by y_1 and y_2 respectively.
 ΔY is the hydraulic jump height.

$$\Delta y = (y_2 - y_1) \dots \dots \dots (1)$$

Length of jump denoted by L_j (Bureau of Reclamation).

$$L_j = 6.9 \Delta y \dots \dots \dots (2)$$

It can be readily shown that (y_2) is given in terms of (y_1) for a rectangular channel (For free hydraulic jump) as follows:

$$y_2 = -\frac{y_1}{2} + \sqrt{\frac{2v_1^2 y_1}{g} + \frac{y_1^2}{4}} \quad \text{(Bureau of Reclamation)} \dots \dots \dots (3)$$

But the Froude number (F_r) as follow:

$$F_r = \frac{v}{\sqrt{gy}} \dots \dots \dots (4)$$

If the Froude's number (Fr) is introduced to equation (3), the Bureau of Reclamation becomes

$$y_2 = \frac{y_1}{2} (\sqrt{1 + 8F_r^2} - 1) \dots \dots \dots (5)$$

(For forced hydraulic jump) Momentum equation is applied in the following form:

$$P_1 + M_1 = P_2 + M_2 + W + F_f + F_p \dots \dots \dots (6)$$

Where:

- P_1 Pressure force at upstream.
- M_1 Momentum force at upstream.
- P_2 Pressure force at downstream.
- M_2 Momentum force at downstream.
- W_w Weight of water. (Neglect as the channel slope is very small)
- F_f Force due to friction. . (Neglect as the channel bed is smooth)
- F_p Force due to blocks

Figure 1 shows the elevation and the plan of the used flume

THE EFFECT OF UNCONVENTIONAL SILLS TO DISSIPATE ENERGY DOWNSTREAM HYDRAULIC STRUCTURES

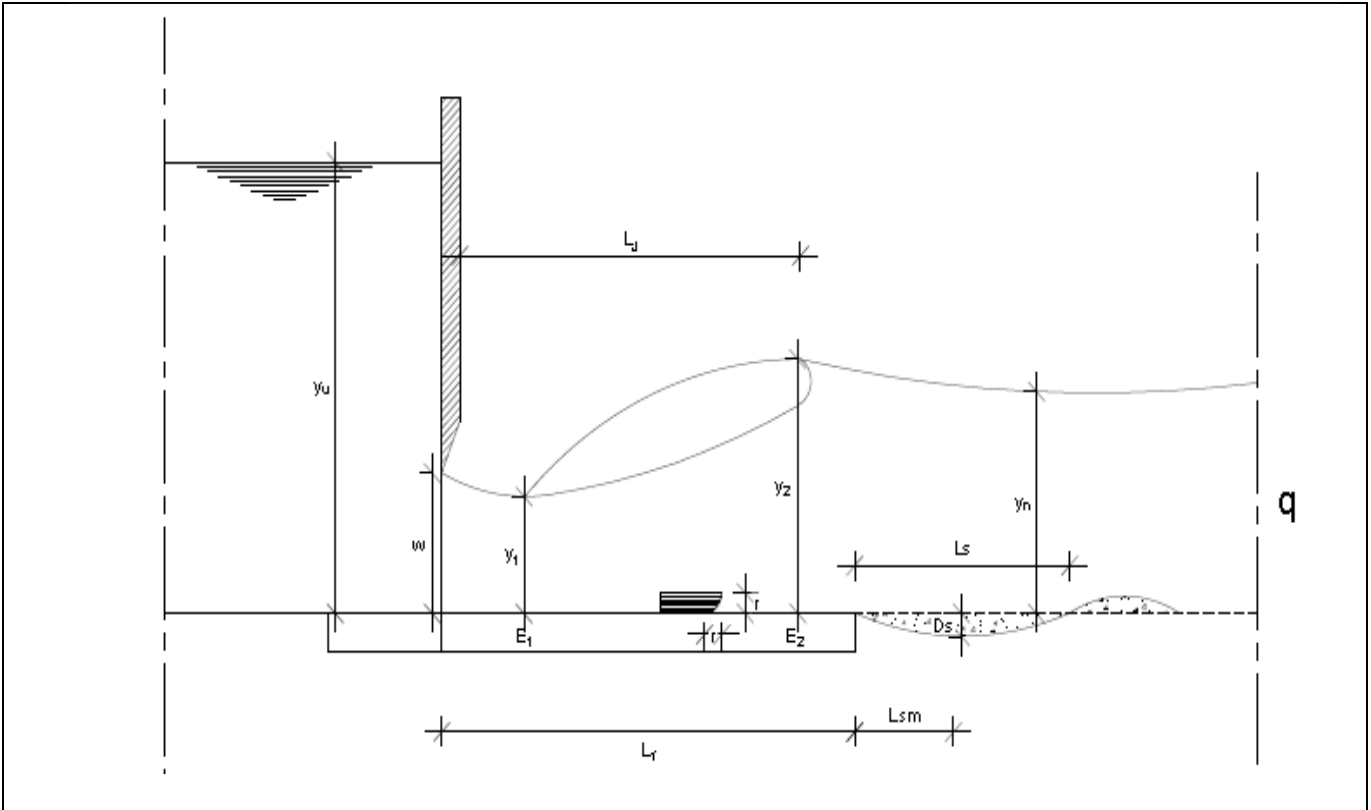

Figure (1-a) Section Elevation

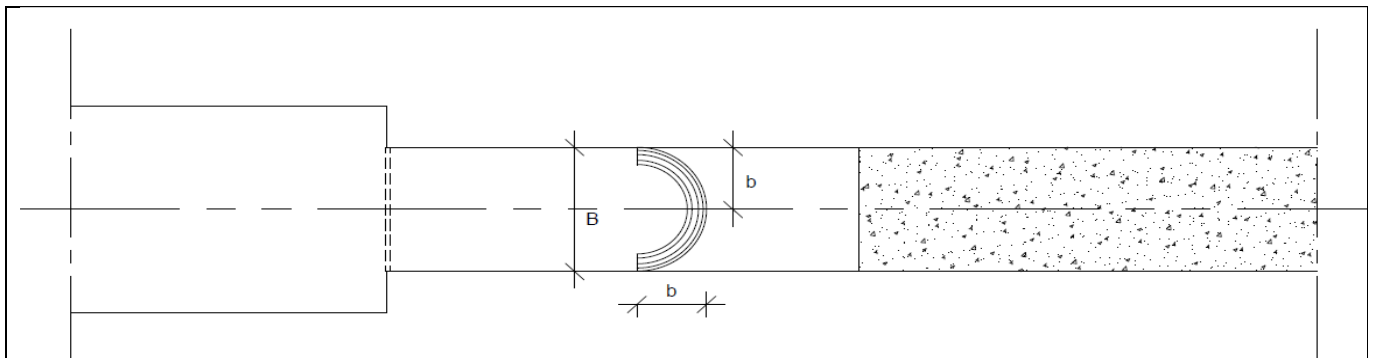

Figure (1-b) Section Plan

The study variables are expressed as follows:

$$\Phi = f(L_f, L_b, L_j, r, b, B, y_1, y_2, y_n, Q, \rho, g, \mu, S.G, D_s, D50, L_s, L_m, \Delta E) \dots \dots \dots (7).$$

Where:

- L_j Length of hydraulic jump.
- D_s Maximum scour depth.
- L_s Maximum scour length.
- L_f Length of floor.

- L_b Distance between vertical gate to the sill.
- y_n Tail water depth.
- r Height of sill.
- b Sill radius in plan.
- B Channel width.
- Q Discharge.
- ρ Density of fluid.
- g Gravity acceleration.
- μ Dynamic viscosity.
- $S.G$ Specific density.
- y_1 Upstream conjunct depth of hydraulic jump.
- y_2 Downstream conjunct depth of hydraulic jump.
- D_{50} Average soil diameter.

According to Buckingham Pi-theorem, the general form of relationship between these variables is also written as follows:

$$\phi = \left(\frac{L_f}{B}, \frac{L_b}{B}, \frac{L_j}{B}, \frac{r}{B}, \frac{y_1}{B}, \frac{y_2}{B}, \frac{b}{B}, \frac{y_n}{B}, \frac{\Delta E}{B}, \frac{Q^2}{B^5 g}, \frac{\rho Q}{B \mu}, \frac{D_s}{B}, \frac{L_s}{B}, \frac{L_m}{B}, \frac{D_{50}}{B}, SG \right) \quad (8)$$

Taking the properties of Pi-terms under consideration, the following relationship may be obtained:

$$\phi_1 = \left(\frac{L_b}{L_f}, \frac{L_j}{L_m}, \frac{L_m}{L_s}, \frac{y_1}{y_2}, \frac{\Delta E}{y_n}, \frac{r}{b}, \frac{D_s}{B}, Fr, SG, R_n, \frac{D_{50}}{B} \right) \dots\dots\dots (9)$$

Where:

- L_b / L_f is the relative length of floor
- L_j / y_1 is the performance of hydraulic jump
- L_m / L_s is the relative scour length
- r / b is the sill ratio
- $\Delta E / B$ is the energy dissipation ratio
- L_s / B is the relative scour length
- L_m / B is the ratio between position of maximum scour length and width of channel
- D_s / y_n is the relative scour depth
- Fr is Froude number
- y_n is tail water depth

Finally, it is summarized as the follows:

$$F_r = \phi \left(\frac{L_b}{L_f}, \frac{L_j}{y_1}, \frac{D_s}{y_n}, \frac{r}{B}, \frac{L_m}{L_s} \right) \dots\dots\dots (10)$$

3. AN EXPERIMENTAL STUDY

The laboratory experiment was conducted in an iron channel with a sector of 30 cm wide, 30 cm high and 400 cm long. In hydraulic laboratory of the faculty of engineering, Al- Azhar - University, Cairo, Egypt, the experimental work was carried out.

THE EFFECT OF UNCONVENTIONAL SILLS TO DISSIPATE ENERGY DOWNSTREAM HYDRAULIC STRUCTURES

The flume consists of square steel frame with transparent sides made of polycarbonate material. The polycarbonate sides of the channel allow visual observation of the water surface, as well as the soil bed. The layout of the flume is shown in details as in **figure (2)** and **photo (1)**.

The model (Q-shaped) was made from quarter of steel pipe. Q-shaped is suggested as non-traditional sill for this study. The model has a height equal to its radius of 2.5 cm and has a Radius of 15 cm in plane.

Four positions are installed and model is placed at the positions relative to the inlet gate with different relative floor length (L_b / L_f) equal to 1.00, 0.75, 0.50, 0.25) respectively to Determine the efficiency of Q-shaped sill to dissipate the energy downstream sluice gate. The flume is consisting of bed floor made from sandy soil with average soil diameter (D50) (0.55 mm) the soil with grain size distribution presented in **figure (3)**.



Photo (1) Experimental Channel

THE EFFECT OF UNCONVENTIONAL SILLS TO DISSIPATE ENERGY DOWNSTREAM HYDRAULIC STRUCTURES

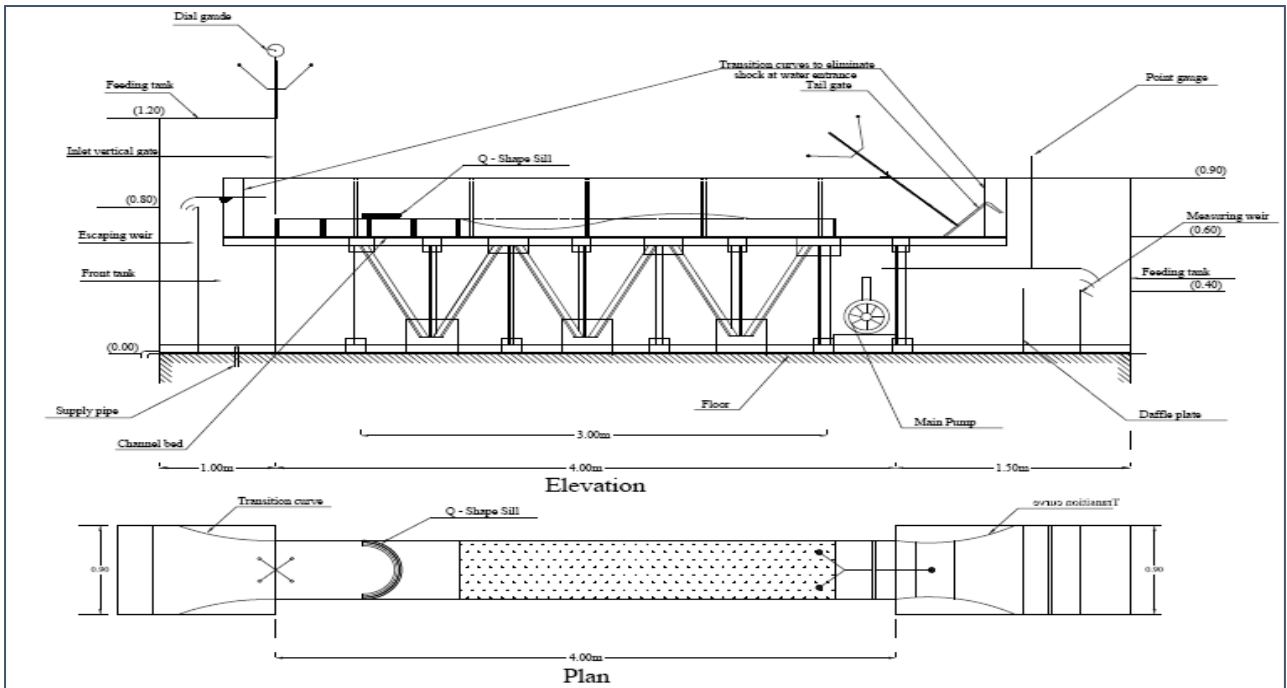

Figure (2) the experimental Channel layout.

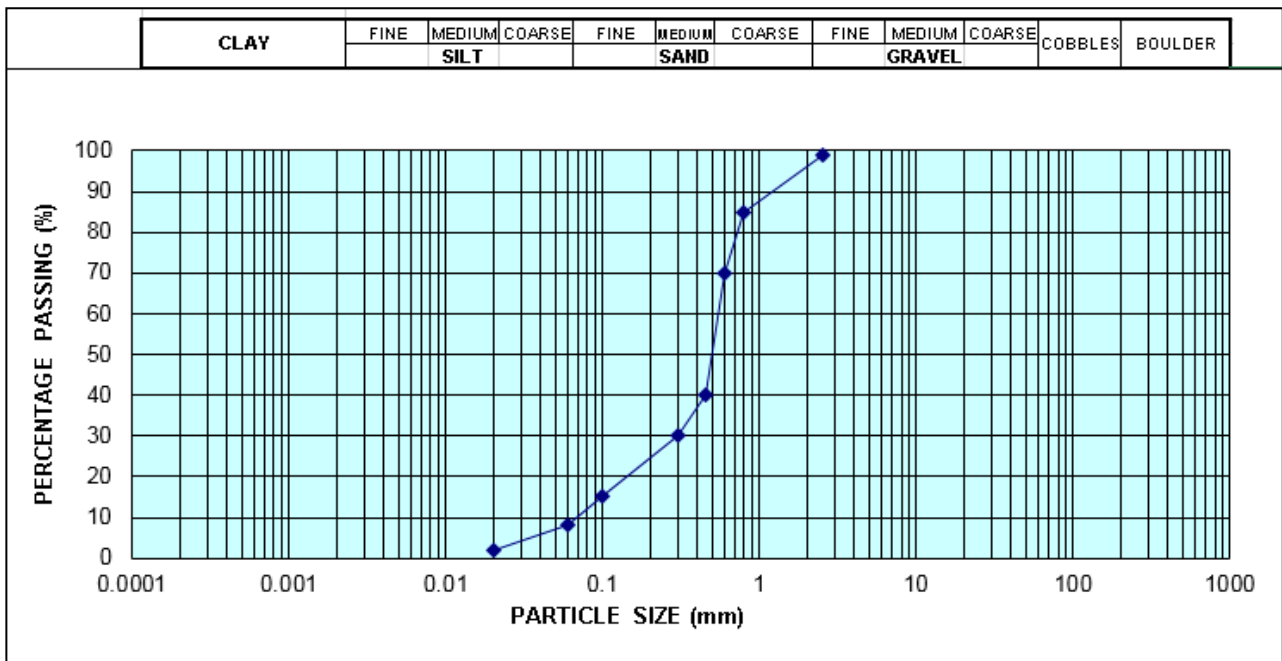

Figure (3) Grain Size Distribution

The channel is fed with water through vertical gate with different opening, get its water from feeding tank and moves towards the downstream from tail gate to the collecting tank. The collecting tank contains sharp edged rectangular weir which measuring the flow rate passing in the channel as shown in **photo (2)**.

THE EFFECT OF UNCONVENTIONAL SILLS TO DISSIPATE ENERGY DOWNSTREAM HYDRAULIC STRUCTURES

The measuring weir was calibrated in the hydraulic laboratory of the Faculty of Engineering, the calibration curve has equation $Q = 0.35 H^{1.5}$. The flow rate (Q) against the head value (H), resulting from the calibration process is also shown in **figure (4)**. Finally, the water moved from the collecting tank to the feeding tank by centrifugal pump.



Photo (2) Measuring Weir

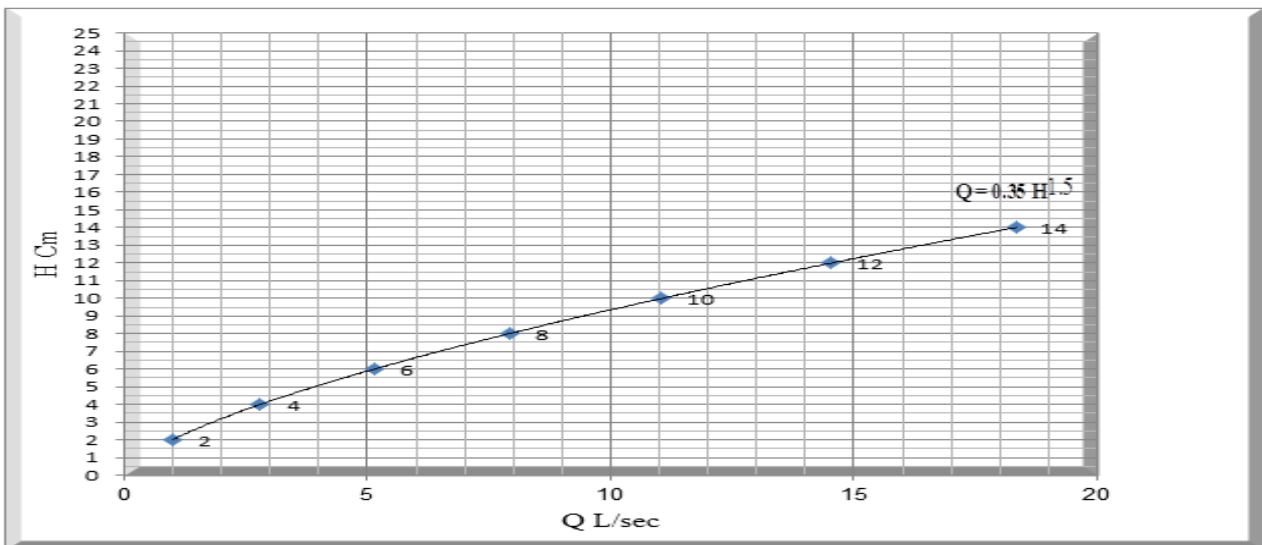

Figure (4) Relation between Q and H

During the run, the model was placed at a certain position, the required discharge was passed, the normal water depth was measured, the hydraulic jump was formed under condition of free flow behind the gate and the formation of a stabilized jump. Depths and lengths were measured as, The sequent depth Y_2 and Jump length L_j is measured from

The leading edge of the jump to a point just downstream from the top roller of the jump. The longitudinal scour whole profile was measured at interval distance of 5cm to find scour whole

length (L_s), maximum scour hole length (L_m) and maximum scour hole depth as shown in **Photo (3)**. The measurements and recordings have been reported and discussed.



Photo (3) Scour Downstream apron

4. ANALYSIS AND DISCUSSION

All measurements, observations and photos were recorded and archived. They were analyzed and plotted on graphs. They are discussed from the point of view of the jump length, energy dissipation ability and scour length with Froude's number, as follows:

4.1. ANALYZING AND DISCUSSING EXPERIMENTAL RESULTS (Fr & L_j/L_{jw})

Figure (5) shows the relationship between L_j/L_{jw} and Fr for different sill position. For all values of L_j/L_{jw} are less than one. This mean that all sill position reduces the apron length of apron under all considered flow conditions.

For all sill position with the different Fr the length of apron reduce as follows:

- ❖ $(L_b/L_f) = 1.00$, it provided a reduction in the length of the jump that ranged from 34% to 47%.
- ❖ $(L_b/L_f) = 0.75$, it provided a reduction in the length of the jump that ranged from 45% to 50%.
- ❖ $(L_b/L_f) = 0.50$, it provided a reduction in the length of the jump that ranged from 52% to 60%.
- ❖ $(L_b/L_f) = 0.25$, it provided a reduction in the length of the jump that ranged from 45% to 52%.

For the case of (Q – shape sill) and all considered flow conditions, it is found that the case of $(L_b/L_f) = 0.50$ gives more reduction percent of apron length.

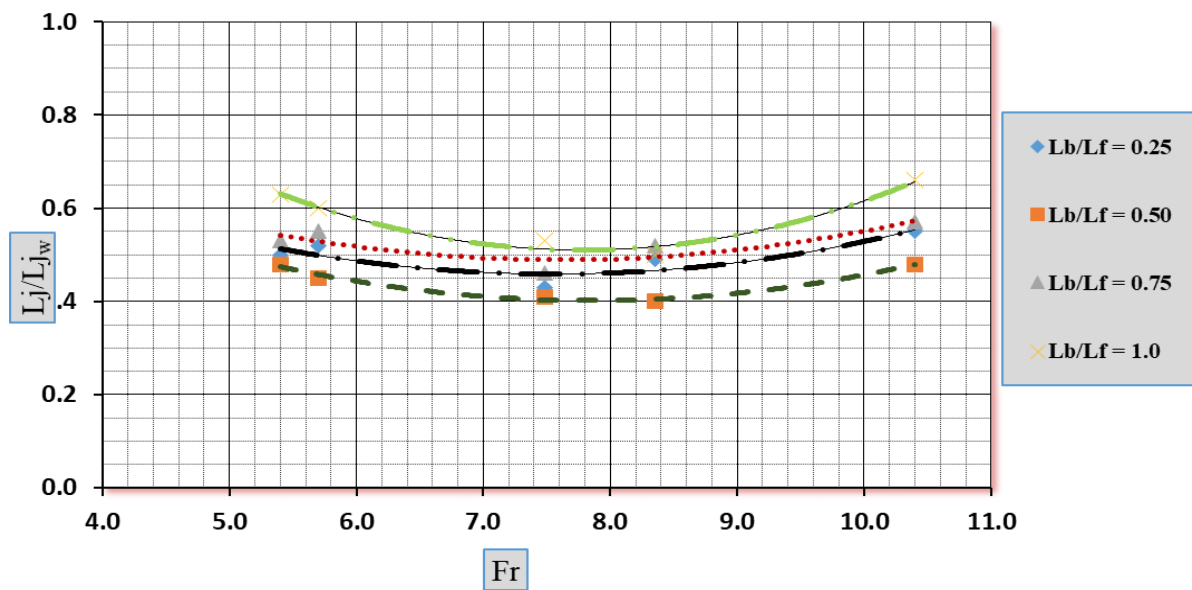

Figure 5 Relation between (Fr) and (L_j/L_{jw})

4.2. ANALYZING AND DISCUSSING EXPERIMENTAL RESULTS (Fr & L_s/L_{sw})

Figure (6), was plotted to present the relation between Fr and L_s/L_{sw} . From the figure, the following were observed:

- ❖ As for (L_b/L_f) = 1.00, it provided a reduction in the scour length that ranged from 8% to 25%.
- ❖ As for (L_b/L_f) = 0.75, it provided a reduction in the scour length that ranged from 20% to 30%.
- ❖ As for (L_b/L_f) = 0.50, it provided a reduction in the scour length that ranged from 30% to 42%.
- ❖ As for (L_b/L_f) = 0.25, it provided a reduction in the scour length that ranged from 25% to 35%.

From the above, obvious was that the appropriate position to the sill, among all the tested cases, is at $L_b/L_f = 0.50$. Provided the maximum reduction in the scour length and relative $L_b/L_f = 1.00$ provided the minimum reduction in the scour length.

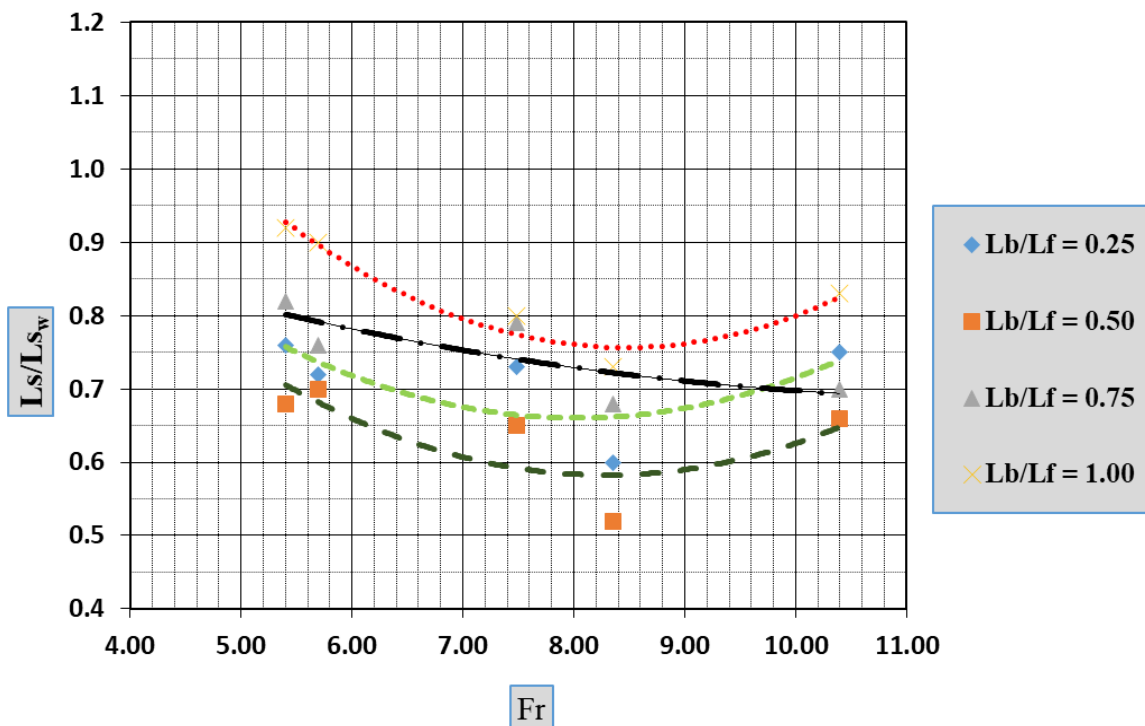

Figure 6 Relation between (L_s/L_{sw}) and (Fr)

4.3. ANALYZING AND DISCUSSING EXPERIMENTAL RESULTS (Fr & E_2/E_{2w})

Figure (7), was plotted to present the relation between Fr and E_2/E_{2w} . From the figure, the following were observed:

- ❖ As for $(L_b/L_f) = 1.00$, it provided a reduction in the specific energy downstream hydraulic jump that ranged from 4% to 12%.
- ❖ As for $(L_b/L_f) = 0.75$, it provided a reduction in the specific energy downstream hydraulic jump that ranged from 6% to 16%.
- ❖ As for $(L_b/L_f) = 0.50$, it provided a reduction in the specific energy downstream hydraulic jump that ranged from 16% to 24%.
- ❖ As for $(L_b/L_f) = 0.25$, it provided a reduction in the specific energy downstream hydraulic jump that ranged from 10% to 20%.

From the above, obvious was that the appropriate position to the sill, among all the tested cases, is at $L_b/L_f = 0.50$. Provided the average maximum reduction in specific energy.

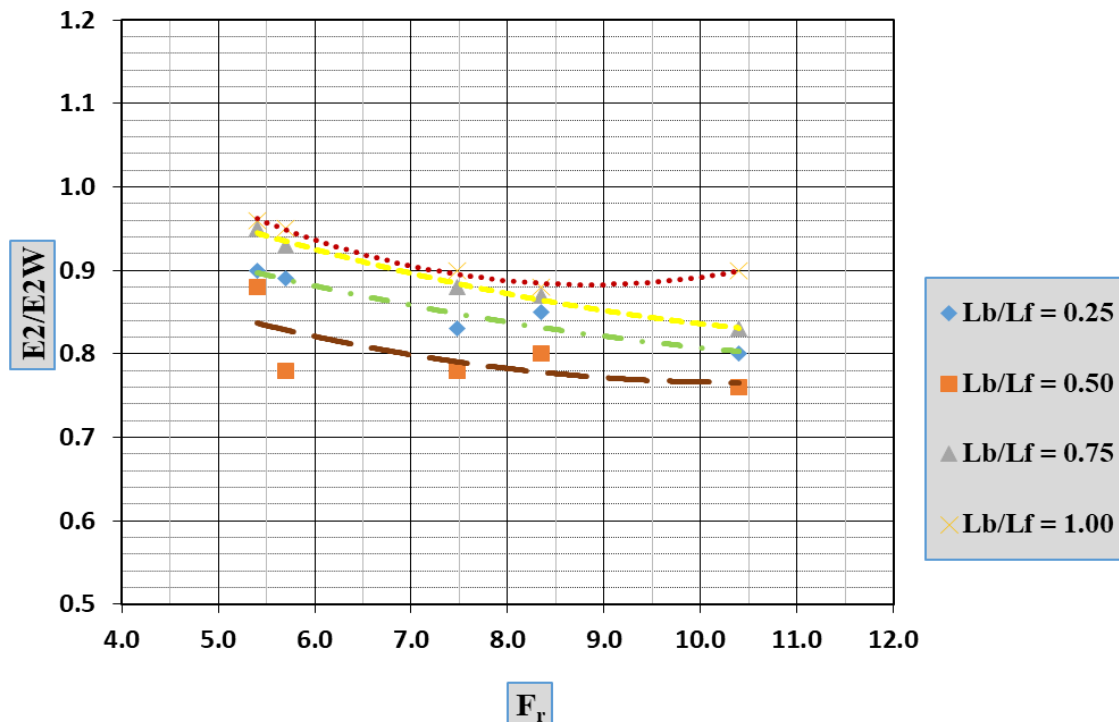

Figure 7 Relation between ($E2/E2W$) and (Fr)

5. CONCLUSIONS AND RECOMMENDATIONS

Based on the above investigation cases, the conclusions are represented as follows:

- The best relative location for the sill is at 0.50.
- The innovative sill form possess a reasonable ability in the energy dissipation
- The innovative sill is reasonable to reduce length of jump, the scour length and relative specific energy for all sill position and for all flow condition.

Based on the above, the following recommendations were foreseen and are given, as follows:

- A wider range of Froude number and discharge are to be tested.
- It is recommended to use sill with different height and relative floor length (L_b/L_f) ranges from 0.25 to 0.50.
- Other innovative sill forms are to be investigated and tested.
- Study the existence of more than sill and group of sills over the floor.
- Study the existing sill on nonrectangular channel.

REFERENCES

- [1] McCorquodale JA, Khalifa AM. (1980) Submerged radial hydraulic jump. J Hydraul Div;106 (3):355-67.

- [2] Abouel Atta, N. (1986). "Study of the Effect of Location and Length of Roughened Beds on Flow Characteristics in Stilling Basins", Unpublished M.Sc. Thesis, Ain Shams University, Cairo, Egypt.
- [3] Hassn, N.M.K., and Narayanan, R. (1986), "Local scour downstream of an apron", *Journal of Hydraulic Engineering*, ASCE Vol. 111, No. 11, P. 1371-1385.
- [4] Hager, W.H. (1992), "Energy dissipators and hydraulic jumps", Kluwer Academic publication, Dordrecht, The Netherlands.
- [5] Aziz F. E., Al-Baidban F. J.H. and Abdul Halim GhazaJil (1999) Dissipation of Hydraulic Energy by Curved Baffle Blocks *Pertanika J. Sci. & Technol.* 7(1): 69-77.
- [6] El-Masry, A.A (2001): "Influence of A Fully Angle Baffled Floor On Scour Behind A Hydraulic Structure" *Mansoura Engineering Journal* Vol. 26, No. 4 Mansoura, Egypt, 2001.
- [7] Shri Ram Chaurasia, (2003): "Direct Equations for Hydraulic Jump Elements in Rectangular Horizontal Channel". *Journal of Irrigation and Drainage Engineering*, Vol. 129, No. 4, July/August, pp. 291-94.
- [8] Saleh, O.K., Negm, A.M., Wahedeldin, O.S. and Ahmad, N.G. (2003), "Effect of end sill on scour characteristics downstream of sudden expanding stilling basins", *Proc. Of 6th Int. Conf. On River Eng. Ahvaz., Iran.*
- [9] Chanson, H., and Brattberg, T., (2004). "Experimental study of the air-water shear flow in a hydraulic jump. " *Int. J. Multiphase Flow*, 26, pp. 583–607.
- [10] Chanson, H. (2004). *The Hydraulics of Open Channel Flow: An Introduction*. Oxford Elsevier Ltd.
- [11] Mostafa Ali (2008): "Using Aprons Of Formed Surfaces As Energy Dissipaters Down Stream Hydraulic Structures". Ph.D. Thesis. Al-Azhar University, Faculty Of Engineering, Cairo, Egypt.
- [12] Ashour, Osama, (2008). control og hydraulic jump by curved sill"" M.Sc. Thesis. Al-Azhar University, Faculty Of Engineering, Cairo, Egypt.
- [13] Ali, A. M., El Gamal, (2008). M. H., Negm, A. M., Helwa, M. F. and Saad, M. B. 'Investigation of flow characteristics downstream radial gates of hammad barrages physical model Twelfth International Water Technology Conference, IWTC12 2008, Alexandria, Egypt.
- [14] Abdelazim M. Ali , Yasser A. Mohamed (2010). "Effect of stilling basin shape on the hydraulic characteristics of the flow downstream radial gates" *Alexandria Engineering Journal*, Vol. 49,P. 393-400.
- [15] Hanaa Mohamed (2010): "Optimum Design of Staggered Concrete Blocks Downstream of Regulators". M.Sc.Thesis. Al-Azhar University Faculty of Engineering, Cairo, Egypt.
- [16] Federico, I., Marrone, S., Colagrossi, A., Aristodemo, F., & Veltri, P. (2010). Simulation of hydraulic jump through sph model'. *IDRA XXXII Italian Conference of Hydraulics and Hydraulic Construction*.Palermo, Italy.
- [17] Jonsson, Patrick , Jonsén, Pär , Andreasson, Patrik, Iundström, T. Staffan and Hellström J. Gunnar I. (2011). Smoothed particle hydrodynamics modeling hydraulic'. *II International Conf. on Particle-based Methods Fundamentals and Applications*
- [18] *Particles*. 2011, Parcelona, Spain.

THE EFFECT OF UNCONVENTIONAL SILLS TO DISSIPATE ENERGY DOWNSTREAM HYDRAULIC STRUCTURES

- [19] Edward, Ching-Ruey LUO,(2013). Analysis and Application of Hydraulic Jump' International Journal of Engineering and Innovative Technology (IJEIT), Volume 3, Issue 2.
- [20] Habibzadeh Alireza, Loewen Mark R, Nallamuthu R. (2014). Mean flow in a submerged hydraulic jump with baffle blocks. J Eng Mech;140(5):40014020 .
- [21] Barlock R, Barkdoll B, Gonza´ (2016). lez-Castro J. Experimental demon- stration of a new extension plate scour countermeasure down- stream of stilling basins. J Hydraul Eng. [http://dx.doi.org/ 10.1061/\(ASCE\)HY.1943-7900.0001183](http://dx.doi.org/10.1061/(ASCE)HY.1943-7900.0001183), 06016013.