

HIGHLY EFFICIENTLY INACTIVATION OF MICROBIAL PATHOGENS USING ADVANCED OZONE GENERATOR UNIT AS AN ECO- FRIENDLY PROMISING STRATEGY

¹Khalifa Ali *, ¹Mohammed G. Barghoth, ¹Said E. Desouky, ²Hanaa H. Elsayed, ¹Mohamed Roushdy

¹Department of Botany and Microbiology, Faculty of Science (Boys), Al-Azhar University, 11884 Nasr, Cairo, Egypt.

²Department of Food Chemistry and Metabolism, National Nutrition Institute, 16 Elkaser Alainy St. Cairo, Egypt.

*Corresponding Author: KhalifaAli.221@azhar.edu.eg

ABSTRACT

Searching for an alternative disinfection and sanitization strategy to control and prevent the contamination and diseases caused by microbial pathogens represents one of the critical challenges for all world governments. So that the antimicrobial efficiency of ozone gas as a terminal disinfectant was estimated at a relatively small level (1.2 mg/l/h) using a unit that was generated as a local unit assembled at the faculty of science against six reference strains including *Staphylococcus aureus* (ATCC 6538), *Bacillus subtilis* (ATCC 9372), *Bacillus spizizenii* (ATCC 6633), *Escherichia coli* (ATCC 8739), *Pseudomonas aeruginosa* (ATCC 9027), and *Candida albicans* (ATCC 10231) for 10, 20, 30 and 40 minutes under laboratory conditions. After 10 min of ozone treatment, the log reduction of cell viability was 97.15%, 59.25%, 24.20%, 24.09%, 14.50 %, 13.47%, and 0.46% for *P. aeruginosa*, strains combination, *E. coli*, *C. albicans*, *B. spizizenii*, *B. subtilis*, and *S. aureus*, respectively. The twenty-minute exposure to ozone resulted in a reduction in microbial viability percent 98.17%, 82.88%, 69.63%, 62.79%, 49.43%, 29.57%, and 28.08%, for *P. aeruginosa*, strains combination, *B. subtilis*, and *E. coli*, *C. albicans*, *S. aureus*, and *B. spizizenii*, respectively. The efficacy of ozone for *P. aeruginosa*, *E. coli*, and strains combination increased by more than 98% after 30 min of ozone treatment followed by 90.41%, 86.76%, 52.63%, and 36.64% for *B. subtilis*, *C. albicans*, *B. spizizenii*, and *S. aureus*, respectively. The maximum ozone efficacy reached 100% for all reference stains except *B. spizizenii* (62.10%) after 40 min of ozone treatment making this strategy a candidate tool recommended for the management and control of the pathogenic microorganisms.

Keywords: Ozone treatment, Microbial elimination, *S. aureus*, *B. subtilis*, *B.spizizenii*, *E. coli*, *P.aeruginosa*, *C. albicans*.

Introduction

Effective sanitation and cleaning of surgical materials and wastes as well as food manufacturing equipment are major challenges in the medical and industrial fields. Due to the inappropriate cleaning method, the contamination by pathogenic microorganisms increased dramatically during the last decades raising substantial public health concerns **Silva et al., (2021)**. Disinfection used in the medical and industrial fields has typically been accomplished using heat, such as hot water or steam, or traditional chemicals, such as chlorine that are completely dissolved in water and easy to use at low cost. Unfortunately, not only are there growing environmental implications about the presence of chemical by-products such as halo-organics created when liquid chemicals are employed as disinfectants but there are also developing public health problems such as respiratory tract and skin irritation (**Alvaro et al., 2009; Selma et al., 2008; Shen et al., 2012**).

The kind of disinfecting agent for using is determined by the nature of microorganisms to be destroyed as well as the quality of the cleaning equipment. If the sanitizing agent is ineffective, the microorganisms multiply and accumulate again on the equipment surfaces (**Dosti et al., 2005**). Among the new disinfectant strategies, ozone (O₃) appears to be a viable method for preventing microbiological contamination by spoilage or microbial pathogens. Ozone, in fact, has a significant antimicrobial activity and is considered an environmentally beneficial technology because of its low environmental impact (**Bigi et al., 2021**).

Ozone is widely applied in several applications as a disinfectant including; treatment of food plant wastes, reuse of waste water, sterilization of food plant equipment's, food surface hygiene and dairy industry (**Graham, 1997; Panebianco et al., 2022**). Ozone is the second strongest oxidizing agent after fluorine (**Miller et al., 1978**). Because of its high oxidation capability, ozone is particularly effective at killing microorganisms. Ozone exhibited biocidal effects on a wide range of species, including Gram- positive and Gram-negative bacteria, spores, and vegetative cells (**Guzel-Seydim et al., 2004; Lezcano et al., 1999**). Ozone has also been shown to kill a variety of viruses, including the hepatitis A, influenza A, and others (**Dosti et al., 2005**).

For practical uses of ozone, different generation techniques are available, with the electrically and photocatalytic (UV) techniques being the most widespread for instance, in the electric corona discharge process, in which the oxygen molecules pass through an electrical field between two electrodes and split (**Brodowska et al., 2018**). Ozone can also be produced by ultraviolet radiation, which involves the passing of oxygen gas molecules through a high-energy short-wave UV light (**Baggio et al., 2020**).

Chemical, thermal, chemo-nuclear, and electrolytic processes are among the other methods of ozone generating (Varga & Szigeti 2016).

Based on the Environmental Protection Agency, ozone is more effective than chemicals in the disinfection process because it has a faster reaction time and does not allow bacteria to regrowth again. The residual ozone breaks down rapidly into oxygen and therefore does not pose a real threat (EPA, 1999). Also, no toxic by-products are found during the ozone treatment process, in comparison to the generation of disinfection by-products (DBP) during using chemicals such as chlorination, which may be mutagenic and carcinogenic. Moreover, the resistances of some organisms to disinfectants, as well as the demand for considerably increased doses for microbial inactivation, are two of the most critical problems in disinfection (Gomes *et al.*, 2019; Greene *et al.*, 1993).

Thus, the purpose of this investigation is to evaluate the action of direct application of ozone gas generated through advanced units against several bacterial species and yeast acting as pathogenic and spoilage organisms including; *S. aureus*, *B. subtilis*, *B. spizizenii*, *E. coli*, *P. aeruginosa*, and *C. albicans*. Also to evaluate the optimal time and the efficacy of ozone gas required to attenuate or control the growth of these pathogens.

Materials and methods

Ozone generation unit

Ozone was generated during this study based on plasma technology through a new design reactor called Dielectric Barrier Discharge plasma reactor (DBD plasma reactor). In this unit, plasma is produced over the dielectric barrier's surface and along the perimeter of the top electrode that is exposed to the surrounding air as represented in Fig. [1].

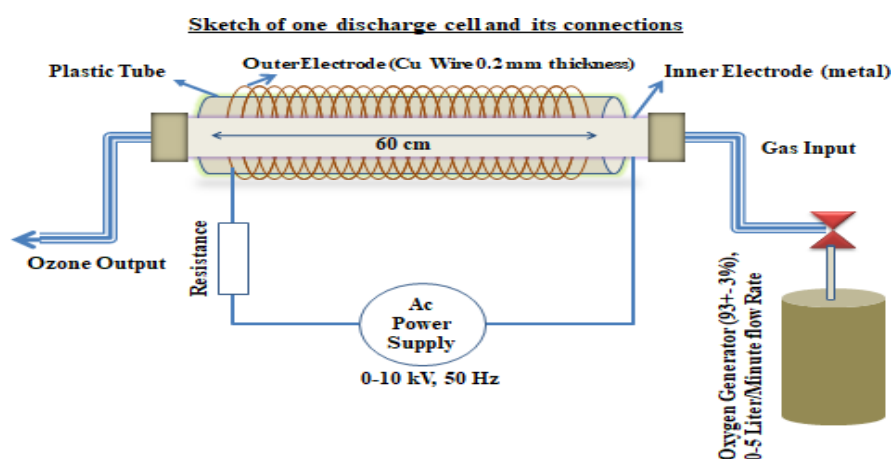

This device was designed and manufactured by Prof. Dr. Safwat Hasaballah at the Faculty of Science, Al-Azhar University. As follows, the two copper electrodes were placed around the outer plastic tube and the inner electrode of the dielectric material (composed of hydrocarbon/ceramic RO4350B™). The thickness of the outer Cu⁺² wire

electrode is 0.2 mm and the length of the inner metal electrode is 60 cm. An alternating potential difference between the two electrodes is used to create DBD plasma around the outer Cu^{+2} wire electrode that is connected to the higher potential (0–10 kv, 50Hz) and exposed to air. Plasma does not form on the bottom side of the reactor because the inner electrode is grounded and covered by a layer of Kapton tape (**Portugal et al., 2017; Choudhury et al., 2018**).

Culture preparation

Test organisms

Reference strains that were used during this study included Gram-positive bacteria such as *Staphylococcus aureus* ATCC 6538, *Bacillus subtilis* ATCC 9372, and *Bacillus spizizenii* ATCC 6633 as well as Gram-negative bacteria represented in *Escherichia coli* ATCC 8739, and *Pseudomonas aeruginosa* ATCC 9027 while unicellular yeast represented in *Candida albicans* ATCC 10231. Bacterial strains were seeded on nutrient agar plates and incubated for 24 h at 37 °C while *C. albicans* was cultured on Sabouraud dextrose agar at 30 °C for 24 h.

Separate colony of each reference strains was transferred from the agar medium to 300 mL of the Muller Hinton broth and allowed to multiply at 37°C for 24 hours. Cells cultured in Muller Hinton broth medium were collected at room temperature using centrifugation at 3000 ×g for 10 min. The supernatant was removed and the cells were harvested and re-suspended in the phosphate-buffered saline (PBS; 0.07M, pH 7.0) until the bacterial inoculum density was equal to 2 McFarland (2MF) approximately 6×10^8 cells/ml when measured spectrophotometrically at absorbance 620 nm (**CLSI, 2018; Sowhini et al., 2020**). Two McFarland standard was prepared by mixing 0.2 mL of 1.175 percent barium chloridedihydrate ($\text{BaCl}_2 \cdot 2\text{H}_2\text{O}$) with 9.8 mL of 1 percent sulfuric acid (H_2SO_4) (**Zapata & Ramirez-Arcos, 2015**).

Experimental set-up

Ozone created by the plasma reactor was transferred to a beaker containing sterile broth media and inoculated with 2 McFarland (6×10^8 CFU/ mL) of the reference test organisms. At pH 6–8 and room temperature 20–25 °C, 50 ml of bacterial suspension was exposed to 1.2 mg/l/h of ozone dosage for interval times ranging from 10 to 40 minutes. The experiments were conducted for each strain alone and in combination for all test organisms with each other. After each test was measured, 180 µL of ozonated bacterial suspension was kept in sterile Eppendorf tubes until the end of the experiments **César et al., (2012)**.

The collected Eppendorf tubes were incubated for 30 min at 37 °C to make sure that the ozone was completely consumed before adding the indicator dye (resazurin). Then 20 µL of resazurin solution was added to each Eppendorf tube and incubated for 4 h at 37°C. All experiments were conducted in triplicate for each test organism **Morgan et al., (2009)**.

Bio-indicator dye preparation

Resazurin solution (7-Hydroxy-3H-phe-noxazin-3-one 10-oxide) was prepared by dissolving 337.5 mg of this dye in 50 mL of sterile distilled water and homogeneity obtained by mixing for 1 hour in a sterile vortex mixer. The preparation processes were carried out in the dark, and the resazurin solution was maintained in a dark bottle to avoid light exposure (Teh *et al.*, 2013). The color of resazurin dye was converted from blue to pink or red fluorescent material (resorufin) by oxidoreductase within live bacterial cells that were used to determine the antibacterial impact of ozone. The change in resazurin color was measured at 570 nm and 600 nm (Pettit *et al.*, 2005; Morgan *et al.*, 2009).

Statistical analysis

Data analysis was performed using ANOVA and the Tukey test after converting the CFU/ml counts to a logarithmic. A statistically significant difference was defined as a P value of less than 0.05. By comparing the groups that were sterilized with ozonated broth media for 10, 20, 30, and 40 minutes to the control group, the hundred percent reductions in CFU/mL for each microorganism investigated was calculated (César *et al.*, 2012). Two control groups were used during this study firstly negative group: contained 180 μ L of sterile nutrient broth media and 20 μ L indicator, without a test organism in which the color of dye remained blue even at the end of the experiment. Secondly positive group: contained 180 μ L of inoculated nutrient broth media and a 20 μ L indicator of 180 μ L without exposure to ozone in which the color of the dye was changed to pink at the end of the experiment.

Results and Discussion

Managing and controlling microbial contamination are represented as one of the main challenges in all life aspects, especially in the medical field. Maintaining a suitable hygienic environment is critical to prevent the dispersion and contamination formed by microbial pathogens. Also searching for advanced strategies to prevent microbial contamination or pathogenic bacteria represents one of the largest challenges facing all industrial and medical branches in the following upcoming years. Therefore newly ozone designed unit was used to generate ozone gas with a low dosage of 1.2 mg/l/h in an aqueous solution.

The antimicrobial action of generated ozone was studied on six microbial reference strains including *Staphylococcus aureus* (ATCC 6538), *Bacillus subtilis* (ATCC 9372), *Bacillus spizizenii* (ATCC 6633), *Escherichia coli* (ATCC 8739), *Pseudomonas aeruginosa* (ATCC 9027), and *Candida albicans* (ATCC 10231) for 10, 20, 30 and 40 minutes as represented in **Table 1**. The initial microbial concentration was adjusted at 2 MF approximately equal to 6×10^8 CFU/ ml or 8.76 ± 0.02 log number of cells.

For *E. coli* (ATCC 8739), there are statistically significant differences observed after ozone exposure for 10 min up to 40 min if compared with the control group. The obtained results showed that the viability of *E. coli* cells gradually decreased after 20 min until disappeared of bacterial cells, this indicated that the activity of ozone is based actually on the exposure time duration. A significant effect

of ozone at a concentration of 2 mg/l/h was used to remove *E. coli* cells in biofilms on lettuce surfaces as reported by **Ölmez & Temur (2010)**. Moreover, the effective inactivation of *E. coli* O157:H7 by ozonated water dose 35 and 45 mg L⁻¹ for 0, 5, 15, and 25 min was studied by **Souza et al. (2019)**. Also, **Mohammad et al. (2019)** demonstrated that the mean log reductions of Shiga toxin-producing *E. coli* when treated with 5 mg/l/h of aqueous ozone after 10, 15, and 20 min, were found to be 1.5 ± 0.4 , 1.6 ± 0.4 , and 2.1 ± 0.5 , respectively.

The same results were obtained for *Pseudomonas aeruginosa* (ATCC 9027) except that the log- transformed CFU/ml was rapidly full down during the first 10 min of ozone exposure from $\log 8.76 \pm 0.02$ to 0.25 ± 0.02 and these results indicated that the highest effectiveness of ozone on *P. aeruginosa* occurred at short exposure time [**Table 1**]. These results are full consistence with data reported by **Dosti et al. (2005)** they found that the largest log reduction of *P. fragi* (ATCC 4973), *P. putida* (ATCC 795), and *P. fluorescens* (ATCC 948) was produced after the 10 min of ozonation process. Our observation is greater than the results observed by **Marino et al. (2018)** who studied the effectiveness of ozonated water instatic and dynamic conditions to demonstrate the sensitivity of *P. fluorescens* to ozone treatments. After 60 minutes of treatment, the authors found that the gaseous ozone at 20 ppm reduced the number of *P. fluorescens* by 5.51 log CFU/cm² (**Marino et al., 2018**).

On the other hand, no statistically significant differences were observed by *S. aureus* (ATCC 6538) after 10 min of exposure to gaseous ozone this may be due to the bacterial resistance or the duration of ozone dose not being enough to reduce the number of bacterial cells. The higher reduction of *S. aureus* cells was obtained after 30 min of ozone exposure and this confirmed that the reduction of bacterial cell numbers was dependent on the ozone exposure duration and this indicated that the greater log reduction was obtained after 30 min of treatment than 10 and 20 min [**Table 1**]. *S. aureus* was highly sensitive to ozonation treatments under dynamic conditions, according to **Marino et al. (2018)**, while contact with gaseous ozone at high doses (20 ppm) resulted in a lowering of 4.72 Log CFU/cm² of *S. aureus* biofilm.

Genus *Bacillus* is one of the most significant spore-forming bacteria, with considerable variety and adaptation to many environmental conditions, as well as the capacity to attach and survive on a variety of surfaces and the ability to produce some biofilm forms (**Shemesh & Ostrov, 2020**). They are easily capable of forming resistant spores that can survive after the conventional cleaning methods that increased the additional disinfectant compounds and raised the cost during the last few yearsto manage the microbial contamination formed by spoilage or pathogenic microorganisms (**Panebianco et al., 2022**).

The bactericidal action of gaseous ozone on *Bacillus subtilis* (ATCC 9372) and *Bacillus spizizenii* (ATCC 6633) demonstrated that lowering reduction in log-transformed CFU/ml 7.58 ± 0.02 and 7.49 ± 0.01 , respectively after the first 10 min of ozone exposure comparing in Contrast to the control group 8.76 ± 0.02 . Both strains showed some resistance toward ozone gas for the first 30 min of contact with ozone followed by a quick fall down in the bacterial cell numbers and this was

revealed primarily by *B. subtilis* then *B. spizizenii* and this may be due to the presence of sporulation character of *Bacillus* genus and hence it required for prolongation of ozone gas exposure also the results indicated that the 30 min of ozone treatment is effective sanitization method to destroy these pathogens

All of the treatments after 10 min of *Bacillus* exposure differ substantially from the controls. The presence of spores may decrease ozone's efficiency. Ozone penetration is likely prevented by the multilayer structure of spores' outer coat. *Bacillus cereus* and *Bacillus megaterium* spores were found to be 10–15 times more resistant to ozone than their vegetative cells as determined by **Broadwater et al. (1973)**. Ozone did not considerably reduce the number of *Bacillus subtilis* spores, according to the data recorded by **Herbold et al. (1989)**. The same results were obtained by **Dosti et al. (2005)** who noted that the response of *B. licheniformis*, was found after 10-min of ozonation treatment. Also, the effect of ozonated water on *B. cereus* biofilms was evaluated by **Babu et al. (2016)** on dairy processing membranes and they found that the average reduction in treat membranes is 1.0 log CFU/cm².

The antimicrobial nature of ozone on *Candida albicans* (ATCC 10231) showed a statistically significant difference relative to the control group after 10 min of exposure (6.65 ± 0.03) and the largest reduction of *Candida* cells obtained after passing 20 min of ozone exposure. The effect of ozonated solution against the combination of all reference strains showed the reduction of microbial quantities from 8.76 ± 0.02 to 3.57 ± 0.05 during the first ten minutes. The complete microbial reduction obtained after 30 min of exposure indicated the higher effectiveness of ozone against the collection of several strains of microbial pathogens.

The efficacy of ozone against the reference strains based on the mean logarithmic reduction concerning the control group after 10 min of exposure to 1.2 mg/l/h of ozone dose was found to be 97.15%, 59.25%, 24.20%, 24.09%, 14.50 %, 13.47%, and 0.46% for *P. aeruginosa*, strains combination, *E. coli*, *C. albicans*, *B. spizizenii*, *B. subtilis*, and *S. aureus*, respectively and this indicated that the largest reduction percent was observed by *P. aeruginosa* while the smallest was observed by *S. aureus* [**Fig. 2**]. Whereas the highest reduction percent achieve after 20 min of ozone treatment was 98.17%, 82.88%, 69.63%, 62.79%, for *P. aeruginosa*, strains combination, *B. subtilis*, and *E. coli*, respectively, and the smallest was found at 49.43%, 29.57%, and 28.08%, for *C. albicans*, *S. aureus*, and *B. spizizenii*, respectively [**Fig. 3**].

After passing 30 min of ozone treatment the efficacy of ozone toward reference strains increased by more than 99% for *P. aeruginosa* and *E. coli* and more than 98% for strains combination followed by 90.41%, 86.76%, 52.63%, and 36.64% for *B. subtilis*, *C. albicans*, *B. spizizenii*, and *S. aureus*, respectively [**Fig. 4**]. Furthermore, the efficacy of ozone reached the maximum reduction yield (100%) for all reference stains except *B. spizizenii* (62.10%) after exposure to ozone for 40 min [**Fig. 5**]. As a result, the net log reduction in the cell viability of the reference strains was found to be largest after 30min for *P. aeruginosa* and *E. coli* and 40 min for the other strains.

Table 1 Effect of ozone on reference strains suspended in broth culture at different experimental times.

Reference Strains	Groups	Mean \pm SD.	Minimum	Median	Maximum	(p)
<i>E. coli</i> (ATCC 8739)	Control	8.76 ^a \pm 0.02	8.74	8.76	8.78	(<0.001*)
	10 min	6.64 ^b \pm 0.09	6.53	6.67	6.71	
	20 min	3.26 ^c \pm 0.75	2.40	3.59	3.78	
	30 min	0.06 ^d \pm 0.01	0.05	0.06	0.07	
	40 min	0.0 ^d \pm 0.01	0.0	0.0	0.01	
<i>S. aureus</i> (ATCC 6538)	Control	8.76 ^a \pm 0.02	8.74	8.76	8.78	(<0.001*)
	10 min	8.72 ^a \pm 0.01	8.71	8.72	8.73	
	20 min	6.17 ^b \pm 0.10	6.07	6.17	6.27	
	30 min	5.55 ^c \pm 0.04	5.52	5.53	5.60	
	40 min	0.03 ^d \pm 0.01	0.02	0.03	0.04	
<i>P. aeruginosa</i> (ATCC 9027)	Control	8.76 ^a \pm 0.02	8.74	8.76	8.78	(<0.001*)
	10 min	0.25 ^b \pm 0.02	0.23	0.25	0.27	
	20 min	0.16 ^c \pm 0.03	0.13	0.17	0.19	
	30 min	0.03 ^d \pm 0.03	0.01	0.02	0.07	
	40 min	0.0 ^d \pm 0.0	0.0	0.0	0.0	
<i>C. albicans</i> (ATCC 10231)	Control	8.76 ^a \pm 0.01	8.75	8.76	8.77	(<0.001*)
	10 min	6.65 ^b \pm 0.03	6.63	6.65	6.68	
	20 min	4.43 ^c \pm 0.02	4.41	4.43	4.45	
	30 min	1.16 ^d \pm 0.05	1.11	1.15	1.21	
	40 min	0.21 ^e \pm 0.02	0.19	0.20	0.23	
<i>B. spizizenii</i> (ATCC 6633)	Control	8.76 ^a \pm 0.01	8.75	8.76	8.77	(<0.001*)
	10 min	7.49 ^b \pm 0.01	7.48	7.49	7.50	
	20 min	6.30 ^c \pm 0.01	6.29	6.30	6.31	
	30 min	4.15 ^d \pm 0.03	4.12	4.15	4.17	
	40 min	3.32 ^e \pm 0.42	3.01	3.14	3.80	
<i>B. subtilis</i> (ATCC 9372)	Control	8.76 ^a \pm 0.02	8.74	8.75	8.78	(<0.001*)
	10 min	7.58 ^b \pm 0.02	7.56	7.59	7.60	
	20 min	2.66 ^c \pm 0.05	2.62	2.64	2.71	
	30 min	0.84 ^d \pm 0.05	0.79	0.84	0.89	
	40 min	0.0 ^e \pm 0.0	0.0	0.0	0.0	
Combination of all referencestrains	Control	8.76 ^a \pm 0.02	8.74	8.75	8.78	(<0.001*)
	10 min	3.57 ^b \pm 0.05	3.51	3.59	3.60	
	20 min	1.50 ^c \pm 0.01	1.49	1.50	1.51	
	30 min	0.11 ^d \pm 0.02	0.09	0.11	0.13	
	40 min	0.0 ^e \pm 0.0	0.0	0.0	0.0	

SD: Standard deviation, Means in the same column with small common letters are not significant at $p \leq 0.05$ (i.e. Means with Different letters are significant)

Recently ozone has an expansive antimicrobial range, and each microorganism species is responsive to the gas in a different manner. Control of fungi, Gram-negative and Gram-positive bacteria, and viruses have all been investigated using the ozonation process (Alwi & Ali 2014; Khadre *et al.*, 2001). Microorganisms are inactivated by ozone through the rupture of the cellular membrane and subsequent dispersion of internal cytoplasmic components due to the higher oxidative potential of this gas. Ozone interacted with the cellular component such as unsaturated fatty acids, nucleic acids, cell wall constituent's enzymes, and other proteins (Sanchez *et al.*, 2016). Based on Manousaridis *et al.*'s observation, the antimicrobial effect of ozone in aqueous media is attributed to their dissociation into molecular ozone, superoxide, and hydroxyl, as well as hydroperoxyl radicals (Manousaridis *et al.*, 2005). However, in the presence of moisture, the harmful effects of ozone are hypothesized to be enhanced due to the increase of these radicals production

(Kowalski *et al.*, 1998).

Our findings indicate that Gram-negative bacteria are more susceptible to gaseous ozone than Gram-positive bacteria similar to the observation reported by Moore *et al.* (2000) who concluded that the Gram-negative bacteria were significantly more sensitive than the Gram-positive bacteria than the yeast strain after being exposed to 2 ppm of ozone for 1 and 4 h.

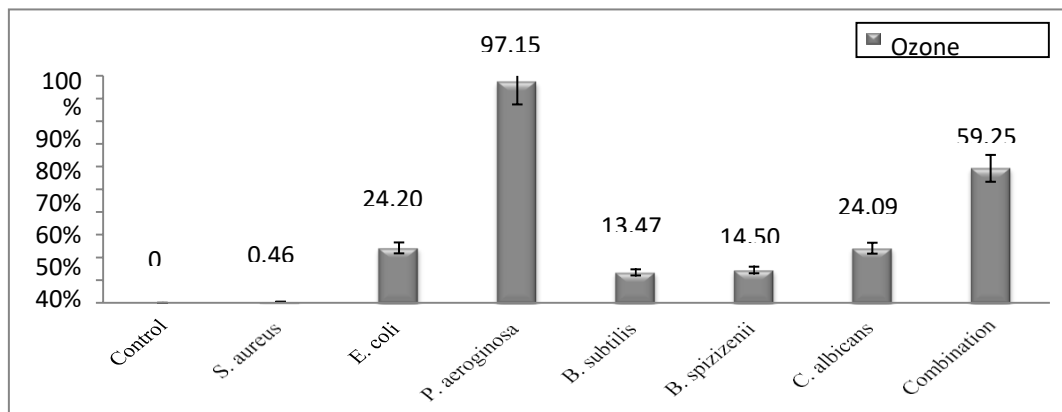

Fig. 2 the efficacy of ozone treatment against the reference strains after 10 min of exposure.

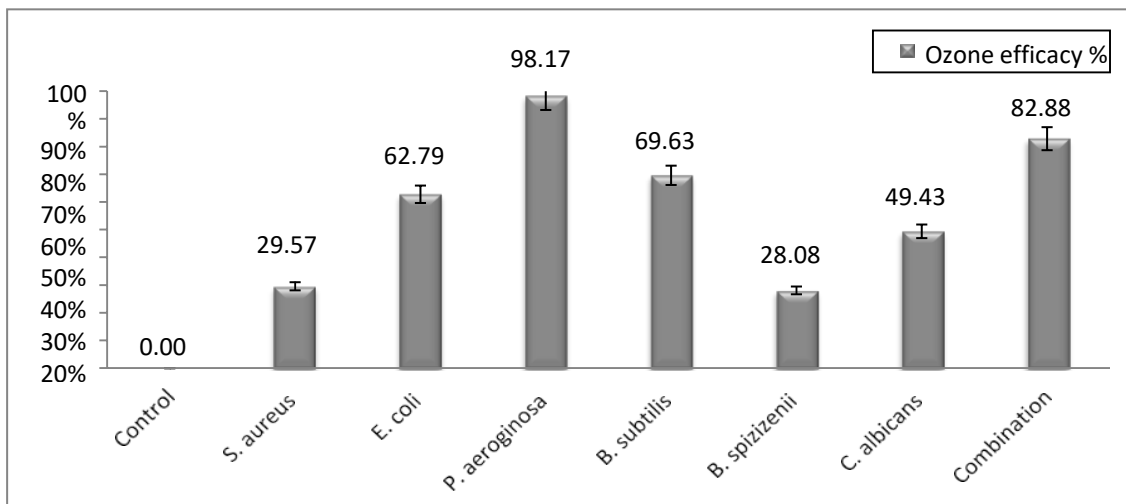

Fig. 3 the efficacy of ozone treatment against the reference strains after 20 min of exposure.

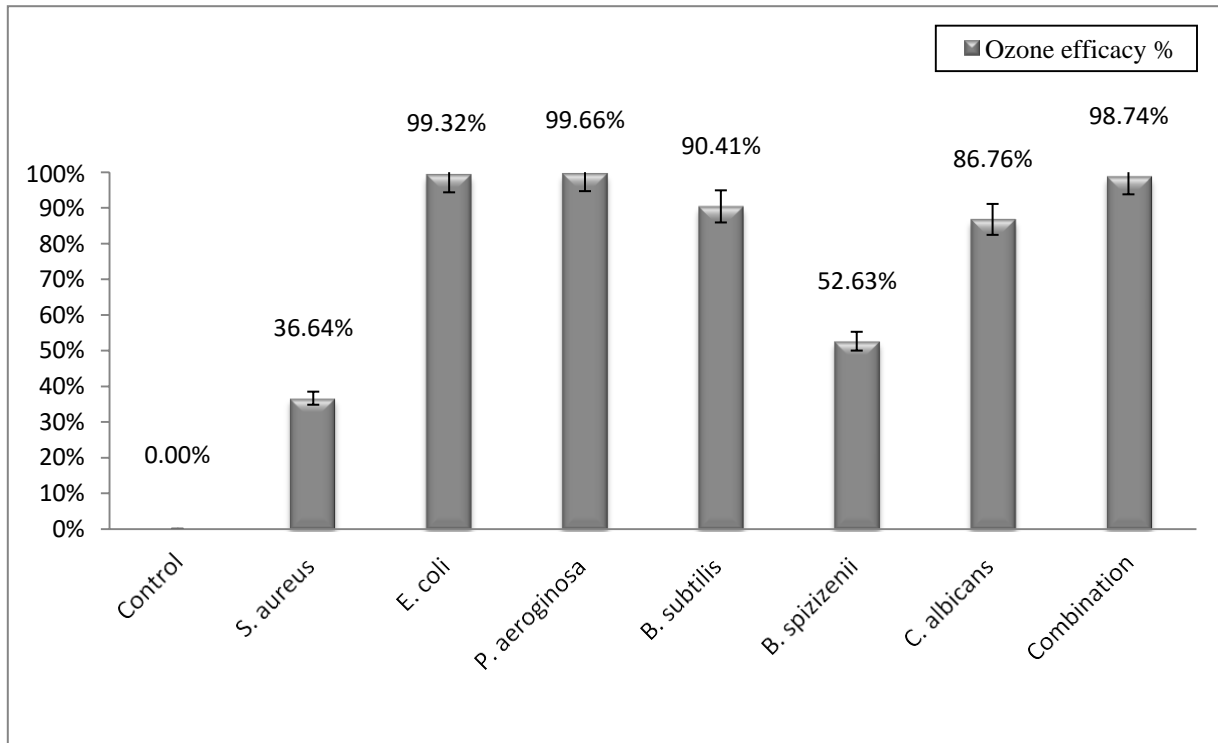

Fig. 4 the efficacy of ozone treatment against the reference strains after 30 min of exposure.

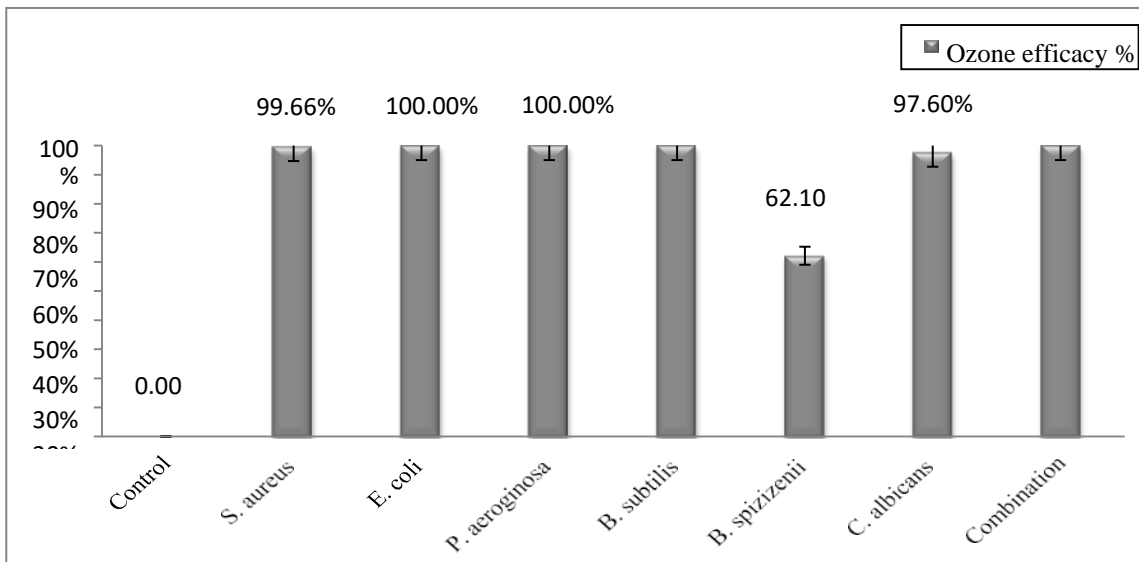

Fig. 5 the efficacy of ozone treatment against the reference strains after 40 min of exposure.

Conclusion

Throughout this study, comparatively small concentrations of gaseous ozone exhibited good antimicrobial capabilities when applied to pathogenic microorganisms. Exposure of six reference strains included *Staphylococcus aureus* (ATCC 6538), *Bacillus subtilis* (ATCC 9372), *Bacillus spizizenii* (ATCC 6633), *Escherichia coli* (ATCC 8739), *Pseudomonas aeruginosa* (ATCC 9027), and *Candida albicans* (ATCC 10231) to ozone gas at the level of 1.2 mg/l/h for 40 min resulted in at least 62 to 100% reduction of the viability of the test organisms. The higher efficiency of the ozone strategy used in this study appeared well among the combination of the strains with 98% and 100% reduction of cell viability after 30 and 40 min, respectively. Gaseous ozone could be utilized as a successful disinfectant agent in different fields, according to the findings of this study, if applied after regular cleaning. Although it is recommended ozone as an effective tool used for traditional sanitation approaches replacement of chemical disinfectants.

References

- Alvaro, J. E., Moreno, S., Dianez, F., Santos, M., Carrasco, G., and Urrestarazu, M. (2009).** Effects of peracetic acid disinfectant on the postharvest of some fresh vegetables. *Journal of Food Engineering*, 95(1), 11-15.
- Teh, C. H., Nazni, W. A., Lee, H. L., Fairuz, A., Tan, S. B., and SOFIAN-AZIRUN, M.(2013).** In vitro antibacterial activity and physicochemical properties of a crude methanol extract of the larvae of the blow fly *Lucilia cuprina*. *Medical and veterinary entomology*, 27(4), 414-420.
- Alwi, N. A., and Ali, A. (2014).** Reduction of *Escherichia coli* O157, *Listeria monocytogenes* and *Salmonella enterica* sv. *Typhimurium* populations on fresh-cut bell pepper using gaseous ozone. *Food Control*, 46, 304-311.
- Babu, K.S.; Liu, Z. and Amamcharla, J.K. (2016).** Use of fluorescence-based Amaltheys analyzer for studying effect of pH and heat on whey protein interactions in reconstituted milk protein concentrate. *J. Anim. Sci.*, 94, 341-342.
- Baggio, A.; Marino, M.; Innocente, N.; Celotto, M. and Maifreni, M. (2020).** Antimicrobial effect of oxidative technologies in food processing: An overview. *Eur. Food Res. Technol.*, 246, 669-692.
- Bigi, F.; Haghghi, H.; Quartieri, A.; De Leo, R. and Pulvirenti, A. (2021).** Impact of low-dose gaseous ozone treatment to reduce the growth of in vitro broth cultures of foodborne pathogenic/spoilage bacteria in a food storage cold chamber. *J. Food Saf.*, 41, e12892.
- Broadwater, W. T., Hoehn, R. C., and King, P. H. (1973).** Sensitivity of three selected bacterial species to ozone. *Applied Microbiology*, 26(3), 391-393.
- Brodowska, A.J.; Nowak, A. and Smigielski, K.B. (2018).** Ozone in the food industry: Principles of ozone treatment, mechanisms of action, and applications: An overview. *Crit. Rev. Food Sci. Nutr.* 58, 2176-2201.

- César, J., Sumita, T. C., Junqueira, J. C., Jorge, A. O. C., and Do Rego, M. A. (2012).** Antimicrobial effects of ozonated water on the sanitization of dental instruments contaminated with *E. coli*, *S. aureus*, *C. albicans*, or the spores of *B. atrophaeus*. *J. of infect and public health*, 5(4), 269-274.
- César, J., Sumita, T. C., Junqueira, J. C., Jorge, A. O. C., and Do Rego, M. A. (2012).** Antimicrobial effects of ozonated water on the sanitization of dental instruments contaminated with *E. coli*, *S. aureus*, *C. albicans*, or the spores of *B. atrophaeus*. *Journal of infection and public health*, 5(4), 269-274.
- Choudhury, B., Portugal, S., Mastanaiah, N., Johnson, J. A., and Roy, S. (2018).** Inactivation of *Pseudomonas aeruginosa* and Methicillin-resistant *Staphylococcus aureus* in an open water system with ozone generated by a compact, atmospheric DBD plasma reactor. *Sci. reports*, 8(1), 1-11.
- Clinical and Laboratory Standards Institute (CLSI) (2018).** Methods for dilution antimicrobial susceptibility testing for bacteria that grow aerobically; approved standard, 11th Ed. *CLSI* document, Wayne, PA. M07-A10.
- Dosti, B.; Guzel-Seydim, Z. and Greene, A.K. (2005).** Effectiveness of ozone, heat and chlorine for destroying common food spoilage bacteriamin synthetic media and biofilms. *Int. J.Dairy Technol.* 58, 19–24.
- EPA (1999).** Wastewater Technology Fact Sheet Ozone Disinfection; EPA: Washington, DC, USA,
- Gomes, João, Ana Matos, Marta Gmurek, Rosa M. Quinta-Ferreira, and Rui C. Martins. 2019).** "Ozone and Photocatalytic Processes for Pathogens Removal from Water: A Review" *Catalysts* 9, no. 1: 46.
- Graham, D. M. (1997).** Use of ozone for food processing. *Food Technol.* 51:72–75.
- Greene, A. K., B. K. Few, and J. C. Serafini. (1993).** A comparison of ozonation and chlorination for the disinfection of stainless steel surfaces. *J. Dairy Sci.* 76:3617–3620.
- Guzel-Seydim Z B, Bever P I and Greene A K (2004).** Efficacy of ozone to reduce bacterial populations in the presence of food components. *Food Microbiol* 21; 475–479.
- Herbold K, Fleming B and Botzenhart K (1989).** Comparison of ozone inactivation, in flowing water, of hepatitis a virus, poliovirus 1, and indicator organisms. *Applied and Environ Microbiol* 55 2949–2953.
- Khadre M, Yousef AE, Kim J (2001).** Microbiological aspects of ozone applications in food: a review. *J Food Sci* ; 66:1242–1252.
- Kowalski, W. J., W. P. Bahnfleth, and T. S. Whittam. (1998).** Bactericidal effects of high airborne ozone concentrations on *Escherichia coli* and *Staphylococcus aureus*. *Ozone Sci. Eng.* 20:205–221.
- L. (2005).** Microplate Alamar blue assay for *Staphylococcus epidermidis* biofilms susceptibility testing. *Antimicrobial Agents and Chemotherapy*, 49(7), 2612-2617.

- Lezcano, I., R. P. Rey, C. Baluja, and E. Sanchez. (1999).** Ozone inactivation of *Pseudomonas aeruginosa*, *Escherichia coli*, *Shigella sonnei*, and *Salmonella typhimurium* in water. *Ozone Sci. Eng.* 21: 293–300.
- Manousaridis G, Nerantzaki A, Paleologos EK, Tsiotsias A, Savvaidis IN and Kontominas MG (2005.)** Effect of ozone on microbial, chemical and sensory attributes of shucked mussels. *Food Microbiol* 22:1–9.
- Marino, M.; Maifreni, M. and Baggio, A. (2018).** Innocente, N. Inactivation of Foodborne Bacteria Biofilms by Aqueous and Gaseous Ozone. *Front. Microbiol.* 9, 2024.
- Miller G W, Rice R G, Robson C M, Scullin R L, Kuhn W and Wolf H (1978.)** An Assessment of Ozone and Chlorine Dioxide Technologies for Treatment of Municipal Water Supplies. US *Environ Protection Agency Report*, No. EPA-600/8-78-018, Cincinnati, OH.
- Mohammad, Z.; Kalbasi-Ashtari, A.; Riskowski, G. and Castillo, A. (2019).** Reduction of *Salmonella* and Shiga toxin-producing *Escherichia coli* on alfalfa seeds and sprouts using an ozone generating system. *Int. J. Food Microbiol.* 289, 57–63.
- Moore G, Griffith C and Peters A. (2000).** Bactericidal properties of ozone and its potential application as a terminal disinfectant. *J Food Prot.* 63(8):1100-6.
- Morgan, N. N., Elsabbagh, M. A., Desoky, S., and Garamoon, A. A. (2009).** Deactivation of yeast by dielectric barrier discharge. *The European Physical Journal-Applied Physics*, 46(3).
- Ölmez, H. and Temur, S. (2010).** Effects of different sanitizing treatments on biofilms and attachment of *Escherichia coli* and *Listeria monocytogenes* on green leaf lettuce. *LWT*,43, 964–970.
- Panebianco, F.; Rubiola, S.; Di Ciccio, P.A. (2022).** The Use of Ozone as an Eco-Friendly Strategy against Microbial Biofilm in Dairy Manufacturing Plants: A Review. *Microorganisms*, 10, 162.
- Pettit, R. K., Weber, C. A., Kean, M. J., Hoffmann, H., Pettit, G. R., Tan, R., ... and Horton, M.**
- Portugal, S., Roy, S., and Lin, J. (2017).** Functional relationship between material property, applied frequency and ozone generation for surface dielectric barrier discharges in atmospheric air. *Sci. reports*, 7(1), 1-11.
- Restaino, L., E. W. Frampton, J. B. Hemphill, and P. Palnikar. (1995).** Efficacy of ozonated water against various food-related microorganisms. *Appl. Environ. Microbiol.* 61:3471–3475.
- Sanchez, B. A. O., de Alencar, E. R., de Oliveira Pineli, L. D. L., de Souza Ferreira, W. F., and de Almeida Roberto, M. (2016).** Tracing interactions among column height, exposure time and gas concentration to dimension peanut antifungal ozonation. *LWT-Food Science and*

Technology, 65, 668-675.

- Selma, M. V., Ibáñez, A. M., Allende, A., Cantwell, M., and Suslow, T. (2008).** Effect of gaseous ozone and hot water on microbial and sensory quality of cantaloupe and potential transference of *Escherichia coli* O157: H7 during cutting. *Food Microbiology*, 25(1), 162-168.
- Shemesh, M. and Ostrov, I. (2020).** Role of *Bacillus* species in biofilm persistence and emerging antibiofilm strategies in the dairy industry. *J. Sci. Food Agric.* 100, 2327–2336.
- Shen C, Luo Y, and Nan X, (2012).** Enhanced inactivation of *Salmonella* and *Pseudomonas* biofilms on stainless steel by use of t-128, a fresh-produce washing aid, in chlorinated wash solutions. *Appl Environ Microbiol* 78:6789–6798.
- Silva, A. L. P., Prata, J. C., Walker, T. R., Duarte, A. C., Ouyang, W., Barcelò, D., and Rocha-Santos, T. (2021).** Increased plastic pollution due to COVID-19 pandemic: Challenges and recommendations. *Chemical Engineering Journal*, 405, 126683.
- Souza, S.M.D.O.; De Alencar, E.R.; Ribeiro, J.L. and Ferreira, M.D.A. (2019).** Inactivation of *Escherichia coli* O157:H7 by ozone in different substrates. *Braz. J. Microbiol.* 50, 247–253.
- Sowhini, N.S.H. & Abdullah Sani, Muhamad Shirwan & Hashim, Yumi & Othman, Rashidi & Maifiah, M.H. & Mohd Desa, Mohd Nasir. (2020).** Antibacterial test and toxicity of plant seed extracts: a review. *Food Res.* 4. 12-27.
- Varga, L. and Szigeti, J. (2016).** Use of ozone in the dairy industry: A review. *Int. J. Dairy Technol.* 69, 157–168.
- Zapata, A., and Ramirez-Arcos, S. (2015).** A comparative study of McFarland turbidity standards and the Densimat photometer to determine bacterial cell density. *Cur. microbiol*, 70(6), 907-909.

القضاء على الميكروبات الممرضة بكفاءة عالية باستخدام وحدة توليد الأوزون المتقدمة كإستراتيجية واعدة صديقة للبيئة

* خليفة علي -¹ محمد جمال برغوث -¹ سعيد السيد دسوقي -² هناء حسين السيد -¹ محمد رشدي

¹ قسم النبات والميكروبيولوجي- كلية العلوم بنين- جامعة الأزهر- ١١٨٨٤ مدينة نصر - القاهرة - مصر.

² المعهد القومي للتغذية قسم كيمياء الأغذية والتمثيل الغذائي- ١٦ ش القصر العيني - القاهرة - مصر.

* البريد الإلكتروني الرئيسي للباحث: KhalifaAli.221@azhar.edu.eg

تبحث هذه الدراسة عن إستراتيجية بديلة لمنع التلوث ومكافحة الأمراض التي تسببها الميكروبات الممرضة ويعتبر هذا أحد التحديات الهامة لكل دول العالم. لذلك تم توليد غاز الأوزون من جهاز محلي الصنع واستخدامه كمطهر فعال بمستوى صغير نسبيا (1.2 ملغم / لتر / ساعة) ضد ست سلالات مرجعية من الميكروبات الممرضة وهي كالتالي المكورات العنقودية الذهبية *S. aureus* (ATCC 6538)، وعصيات رقيقه *B. subtilis* (ATCC 9372)، عصيات سببيزيني *B. spizizenii* (ATCC 663)، والإشريكية القولونية *E. coli* (ATCC 8739)، والزائفة الهوائية أو الفصيله الزنجارية *P. aeruginosa* (ATCC 9027)، والمبيضات البيضاء *C. albicans* (ATCC 10231) لمدة 10 و 20 و 30 و 40 دقيقة تحت ظروف معملية.

بعد 10 دقائق من معالجة الأوزون، كانت نسب كفاءة الأوزون في القضاء على الخلايا الميكروبية الحية كالتالي 97.17%، 59.25%، 24.20%، 24.09%، 14.50%، 13.47%، و 0.46% ل *P. aeruginosa*، مزيج السلالات، *E. coli*، *C. albicans*، *B. spizizenii*، *B. subtilis*، و *S. aureus*، على الترتيب.

أدى التعرض للأوزون لمدة عشرين دقيقة إلى انخفاض نسب الخلايا الميكروبية الحية كتأثير فعال للأوزون بنسبه تصل إلى 98.17%، و 82.88%، و 69.63%، و 62.79%، و 49.43%، و 29.57%، و 28.08%، ل *P. aeruginosa*، مزيج من السلالات، *B. subtilis*، و *B. spizizenii*، و *S. aureus*، *C. albicans*، و *E. coli*، على الترتيب.

زادت فعالية الأوزون ل *P. aeruginosa* و *E. coli* ومزيج من السلالات معا بأكثر من 98% بعد 30 دقيقة من العلاج بالأوزون تليها 90.41% و 86.76% و 52.63% و 36.64% ل *B. subtilis* و *C. albicans* و *B. spizizenii* و *S. aureus*، على الترتيب.

وصلت فعالية الأوزون القصوى إلى 100% لجميع السلالات الميكروبية باستثناء (62.10%) *B. spizizenii* (بعد 40 دقيقة) من المعالجة بالأوزون مما يجعل هذه الإستراتيجية أداة مرشحة موصى بها لمكافحة الكائنات الحية الدقيقة المسببة للأمراض والسيطرة عليها.

الكلمات المفتاحية: معالجة الأوزون، القضاء على الميكروبات،

S. aureus, *B. subtilis*, *B. spizizenii*, *E. coli*, *P. aeruginosa*, and *C. albicans*.