



ISSN 1110-0451

## Arab Journal of Nuclear Sciences and Applications

Web site: [ajnsa.journals.ekb.eg](http://ajnsa.journals.ekb.eg)



IAEA

### Quality Assurance and Quality Control Programmes of Research Reactor Operation and Utilization at GHARR-1 Facility

E. Shitsi\*, H. C. Odoi, I.K. Baidoo, E. O. Amponsah-Abu, K. Gyamfi, E.K. Bofo, H.K. Obeng, P.D. Gasu, W. Osei-Mensah, W. S. Massiasta, R.E. Quagraine

Nuclear Reactors Research Centre, National Nuclear Research Institute, Ghana Atomic Energy Commission. P.O. Box LG 80, Legon-Accra, Ghana

#### ARTICLE INFO

##### Article history:

Received: 27<sup>th</sup> Oct. 2022

Accepted: 6<sup>th</sup> Jan. 2023

##### Keywords:

Quality Assurance and Quality Control;

Research Reactor Operation;

Neutron Activation Analysis;

Reactor Maintenance

#### ABSTRACT

**Quality Assurance and Quality Control (QA/QC) of Research Reactor Operation (RRO) and utilization activities at GHARR-1 facility ensures that all activities carried out by Research Reactor Operators and Neutron Activation Analysis (NAA) Experts follow standard operating procedures and specifications. NAA in GHARR-1 facility involves sample preparation, sample transfer, sample counting and sample analysis. Monitoring of these activities ensures that qualitative and quantitative results of elemental analysis produced by the GHARR-1 facility are precise and accurate. Reactor Operation also involves setting neutron flux for startup, and monitoring associated parameters on the Control Console (CC) during reactor operation. QA/QC monitoring and evaluations forms have been developed for sample preparation, sample transfer, sample counting, sample analysis, reactor operation and reactor maintenance activities. These forms are used to monitor the performance of reactor operation and NAA to help in early detection of any irregularities and faults arising from these activities. This work presents how QA/QC monitoring programmes developed for the various activities of reactor operation and NAA are carried out at GHARR-1 facility to ensure standard operating procedures and specifications are followed to produce Qualitative and Quantitative analysis reports of elemental analysis.**

#### 1. INTRODUCTION

The Ghana Research Reactor-1 (GHARR-1) with HEU (high-enriched uranium) core was changed to LEU (low-enriched uranium) core in 2017. The HEU core with 90.2 % enrichment and 30 kW power was installed in December 1994, commissioned in March 1995, shut down in June 2016 and was removed from the reactor vessel and stored in Interim Transfer Cask (ITC) in August 2016. The LEU core with 13 % enrichment and 34 kW power was installed in July 2017 and commissioned in August 2017. The HEU core and the LEU core achieved criticality in 17<sup>th</sup> December 1994 and 13<sup>th</sup> July 2017 respectively. Both the HEU and LEU cores were designed by the China Institute of Atomic

Energy (CIAE). The HEU core was returned to China in August 2017.

The GHARR-1 facility is mainly used for Research and Development (R&D) in nuclear technique and nuclear engineering, Neutron Activation Analysis (NAA), human resource development for Ghana's nuclear power programme and for education and training [1, 2]. Table (1) shows comparison of technical specification of Ghana Miniature Neutron Source Reactor (MNSR) LEU core with that of the HEU core. Figure (1) and Figure (2) show schematic diagram of the coolant flow pattern and the arrangement of 335 fuel rods and 15 dummy rods of 350 lattice structure of the LEU core respectively.

The main goal of Management System (MS) programme of GHARR-1 is to improve quality assurance and quality control procedures and implementation in research and service delivery. The objectives are to ensure safety of workers and public as well as delivery of quality services that meet standard requirements and specifications. Quality assurance (QA) in a management system provides confidence that specific requirements will be fulfilled, while quality control (QC) verifies that structures, systems and components of a nuclear power plant correspond to predetermined requirements (IAEA Safety Glossary [3]). Other documents that guide the development of GHARR-1 QA/QC programme also known as Management Systems include IAEA Safety Reports Series No. 75 [4], IAEA Safety Guide No. GS-G-3.5 [5], IAEA Specific Safety Requirements No. SSR-3 [6], IAEA General Safety Requirements No. GSR Part 2 [7], IAEA Safety Standards Series No. SSG-12 [8], IAEA Safety Requirements No. NS-R-4 [9], IAEA General Safety Requirements Part 1, No. GSR Part 1 [10] and ISO 9001 [11]. QA/QC ensures that the safety procedures for carrying out activities including Radiation Monitoring, Reactor Operation and Neutron Activation Analysis NAA are observed. Adherence to safety procedures in carrying out these activities ensures that the workers are safe and the public are also safe anytime they visit the Centre. Adherence to safety procedures also ensures that irradiation of various geological, biological and liquid samples for elemental determination (NAA) and preparation of reports on irradiated samples are carried out to meet required specifications.

This work presents how QA/QC monitoring programmes developed for the various activities of reactor operation and NAA are carried out at GHARR-1 facility to ensure standard operating procedures and specifications are followed to produce Qualitative and Quantitative analysis reports of elemental analysis.

## **2. Monitoring of Sample Preparation, Sample Transfer, Sample Counting and Sample Analysis Activities**

Elemental concentration determination (or NAA) involves sample preparation, sample transfer, sample counting and sample analysis activities. Carrying out these activities according to specific standard QA/QC procedures/guidelines prevents the occurrence of non-conformance issues, and hence gives customers confidence/trust on elemental concentration determination reports produced from the NAA. QA/QC monitoring Forms are therefore developed to guide the activities of NAA. Sample preparation form is shown in Form 1. As can be seen from the Form 1, all vital information needed for sample analysis from sample preparation stage are indicated in the form. This information also reminds the NAA experts carrying out the NAA to log-in all the necessary sample preparation information. Sample Transfer form is shown in Form 2. As can be seen from the Form 2, all vital information needed for sample analysis from sample transfer stage are indicated in the form. Other information on amount of radiation release by the irradiated samples and condition of sample transfer capsules are also indicated in the form 2. Sample Counting form is shown in Form 3. As can be seen from the Form 3, all vital information needed for sample analysis from sample counting stage are indicated in the form. Other information such as average dead time and counting/measurement time are also indicated in the form 3. Sample Analysis form is shown in Form 4. As can be seen from the Form 4, all necessary information needed for sample analysis and QA/QC verification are indicated in the form (analysis values of the CRMs irradiated with the samples compared with the reported values of the same CRMs already in the  $k_0$ -IAEA software).

**Table (1): Comparison of key parameters for reference GHARR-1 HEU and LEU cores [1, 2].**

<b>Key Parameters</b>	<b>HEU</b>	<b>LEU</b>
Reactor type	MNSR	MNSR
Fuel type	rod	rod
Power, kW	30	34
Fuel rod lattice	350	350
Number of Active Fuel rods	344	335
Number of Dummy rods	6	15
Core diameter (mm)	230	230
Core height (mm)	230	230
Fuel lattice pitch (mm)	10.95	10.95
Coolant inlet pressure (atm)	1	1
Coolant heat transfer mode	Natural convection	Natural Convection
Reflector	Beryllium	Beryllium
Control rod absorber	Cadmium	Cadmium
Control rod cladding	Stainless steel	Stainless steel
Number of control rods	1	1
Core shape	Cylindrical	Cylindrical
Coolant/moderator	Deionised water	Deionised water
Fuel Meat	U-Al <sub>4</sub>	UO <sub>2</sub>
U-235 Total Core Loading, g	~998.1	~1355.3
U-235 Enrichment, wt%	90.2	13.0
U-234 content, wt%	1.0	0.2
U-236 content, wt%	0.5	0.25
Density of Meat, g/cm <sup>3</sup>	3.456	10.6
Meat Diameter, mm	4.3	4.3
Cladding Diameter, mm	5.5	5.5
Thickness of He Gap, mm	None	0.05
Cladding Material	Al-303-1	Zirc-4
Material for Grid Plates	LT-21	Zirc-4
Top Shim Tray	LT-21	LT-21
Material for Dummy Elements	Al-303-1	Zirc-4
Number of Tie Rods	4	4
Material for Tie Rods	Al-303-1	Zirc-4
Adjuster Guide Tubes	4	4
Effective Delayed Neutron Fraction	$8.08 \times 10^{-3}$	$8.57 \times 10^{-3}$
Prompt neutron lifetime (s)	$8.12 \times 10^{-5}$	$1.41 \times 10^{-4}$
Maximum thermal Neutron flux, n/cm <sup>2</sup> s	$1 \times 10^{12}$	$1 \times 10^{12}$
Excess reactivity, mk	4.0	3.87
Control rod worth, mk	7.0	6.90
Shutdown margin, mk	3.0	3.03

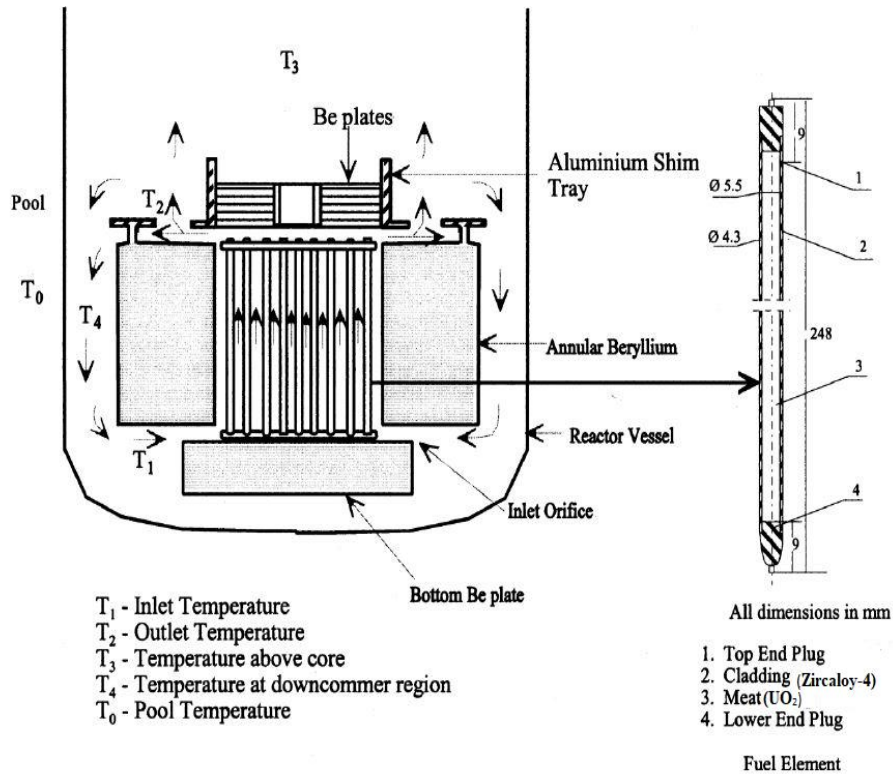

Fig. (1): A schematic diagram of the coolant flow pattern in GHARR-1 [1, 2]

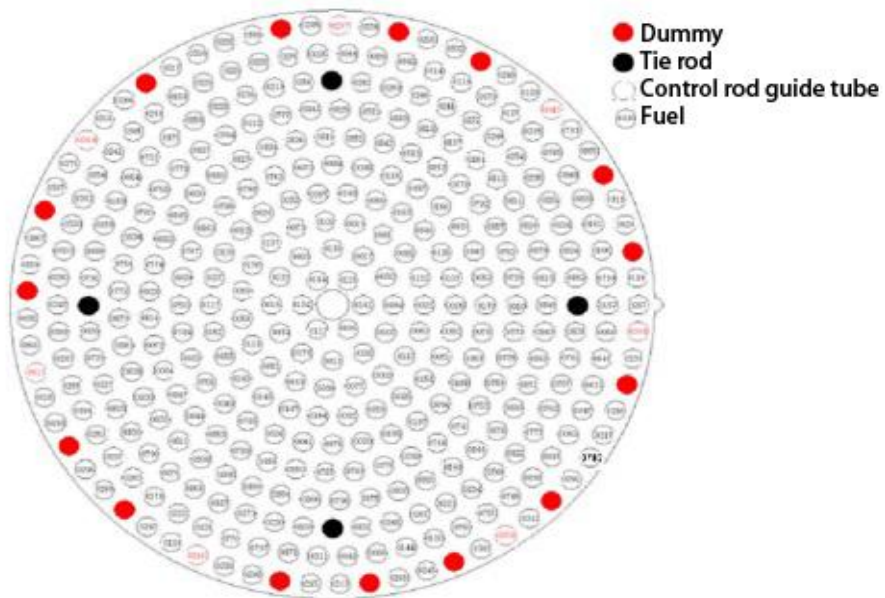

Fig. (2): Fuel element arrangement of GHARR-1 core [1, 2]

**Form 1. Sample Preparation**

Our ref: QAQC/NRRC/SP ..... Sample No(s) or ID(s).....

**Quality Assurance and Quality Control (QA/QC) Checks for Sample Preparation (SP)**

Sample date, sample IDs and sample masses well recorded in the sample preparation book (Select Yes or No) .....

At least 2 certified reference materials (CRMs) and a gold standard (wire or foil) were also prepared, IDs and masses well recorded in the sample preparation book for each set of samples prepared for Short, Medium or Long periods of irradiation (Select Yes or No) .....

Samples well packaged and sealed using packaging materials and soldering iron to prevent/minimize sample breakages during sample transfer and irradiation (Select Yes or No) .....

Select the form of sample prepared (powder, liquid, wire, foil, slab) that was prepared .....

Remarks/Observations: .....

QA/QC Officer Name: Signature:

NAA-Sample Preparation Name: Signature:

Team Member

Centre Manager Name: Signature:

Date: .....

**Form 2. Sample Transfer**

Our ref: QAQC/NRRC/ST/INT/..... Sample No(s) or ID(s).....

**Quality Assurance and Quality Control (QA/QC) Checks for Sample Transfer (ST)**

Sample transfer procedures read prior to the start of Sample Transfer In and Out of the reactor (Select: Yes or No) .....

Neutron Flux stable at ..... n cm<sup>-2</sup> s<sup>-1</sup>

Radiation Monitor and Watch (Timer) available for monitoring radiation dose and recording irradiation time (Select: Yes or No) .....

Sample receiving container well stuffed with foam rubber material to prevent/minimize rabbit capsule breakage (Select: Yes or No) .....

Sample transfer irradiation site used: Inner site..... or Outer site ..... (Indicate it)

Minimum and maximum radiation dose of irradiated samples:

.....and ..... μSv/hr (Short Sample)

.....and ..... μSv/hr (Medium Sample)

.....and ..... μSv/hr (Long Sample)

Number of rabbit capsules broken during irradiation .....

Number of irradiated samples retrieved from broken rabbit capsules .....

Number of irradiated samples that were not retrieved from broken rabbit capsules .....

Sample transfer and sample irradiation information well recorded in the sample transfer log-book; sample ID, sample description, time in and out, irradiation site and dose (Select: Yes or No) .....

Is the irradiation time for the CRM(s) the same for that of the samples? (Select Yes or No) .....

The irradiation time used for the Au flux monitor is.....

The irradiation Timer and Counting System Time synchronized (Select Yes or No) .....

Purpose of Sample Transfer: ... ..

Remarks/Observations: .....

**Form 3. Sample Counting/M Measurement**

Our ref: QAQC/NRRC/SP and SC/INT/..... Sample No(s) or ID(s).....

**Quality Assurance and Quality Control (QA/QC) Checks for Sample Counting (SC) of irradiated/activated sample**

The counting software opened for counting (select Yes or No) .....

Folder created for saving the spectra of the various samples to be counted (Select Yes or No) .....

The Counting System Computer Time and Sample Transfer Stop Watch Time synchronized, the counting/measurement time is set, high voltage is on, the

detector is on and selected for the counting (Select Yes or No) .....

The counting/measurement time is ..... (Indicate it)

The Dead Time percentage less than 20% during counting (Select Yes or No) .....

The average dead time is ..... (Indicate it)

Purpose of the Sample Preparation/Counting: .....

Remarks/Observations: .....

**Form 4. Sample Analysis**

Our ref: QAQC/NRRC/SA/INT/.....

Sample No(s) or ID(s).....

*Please complete the form for analysis results given to clients in soft-copy or hard-copy form*

**Quality Assurance and Quality Control (QA/QC) Checks for Sample Analysis (SA)**

Folder created in the counting folder for sample analysis (Select Yes or No) .....

The k0 IAEA software opened for Sample Analysis (select Yes or No) .....

Samples, Packaging, Activation and Measurement information well entered (Select Yes or No) .....

Sample analysis and QA/QC verification performed (Select Yes or No) .....

Mass of the Au monitor used for the analysis .....

Neutron flux estimated for the analysis using the Au monitor .....

Analysis type	Radionuclides	Concentration of Standard (mg/kg)		Concentration of Standard (mg/kg)	
		Standard Name .....	Analysis value	Standard Name .....	Reported Value
Short	Mn				
	V				
Medium	La				
	Mn				
	As				
	Na				
	K				
Long	Th				
	Fe				
	Co				
	Cs				

\*Standard denotes Certified Reference Material (CRM)

Purpose of the Sample Analysis: .....

Remarks/Observations: .....

### 3. Monitoring of Reactor Operation and Maintenance Activities

Annual maintenance programme carried out at GHARR-1 facility involves maintenance activities such as (1) Voltage and resistance measurements of the Micro Computer Close Looped System (MCCLS) and the Control Console; (2) Testing and Calibration of the Micro-Current Amplifier; (3) Neutronics and thermal hydraulics measurement; (4) Servicing and test run of the control drive mechanism; (5) Servicing of the compressor machine; (6) Test and run of the pneumatic systems; (7) Servicing of the iodine filter of the Gas purge; (8) Greasing and oiling of crane chains; (9) Testing and calibration of gamma probes; (10) Testing and calibration of temperature and conductivity probes; (11) Calibration of Pen dosimeter; (12) Servicing of vent pumps; (13) Pool Cleaning; (14) Servicing of the deionised and purification plants; (15) Servicing of the purification pumps at the IMTF; (16) Servicing of the freeze dryer; (17) Testing manual crane at purification room; (18) Testing of 3D electric crane at reactor hall; and (19) Testing of 1D electric crane at IMTF (International MNSR Training Facility). Parameters of some of the maintenance activities are measured/tested and the values recorded for comparison to previous measurements. These maintenance activities include activities (1), (2), (3), (9), (10) and (11).

Reactor Operation and Maintenance activities involve starting and operation of the reactor for NAA, carry out regular maintenance, and faults detection and correction/rectification due to components failure. Form 5 shows QA/QC Form for reactor operation. As can be seen from the form, all the necessary information provided to help remind the operators of the start-up checks for reactor operation. Shut-down checks are also mentioned in the form 5 to remind the operators of reactor shutdown procedures/guidelines. Information necessary to estimate the actual reactor power produced in the reactor core during reactor operation are also provided in the form 5 for comparison with the Control console set-up power (or flux). This is to ensure that the power setting on the Control Console (CC) produces the required neutron flux in the reactor core. Form 6 shows Fault detection and Correction form in which faults detected and the corresponding actions taken to correct the faults are documented.

### Form 5. Reactor Operation

Our ref: QAQC/NRRC/RO/INT/.....

Sample No(s) or ID(s) : .....

#### Quality Assurance and Quality Control (QA/QC) Checks for Reactor operation

Checks	Yes/No
1. Sample Transfer Pressure within 0.4 to 0.67 MPa	
2. Reactor operation check list followed prior to the start of reactor operation	
3. Flux stable at the required flux (half power, $5 \times 10^{11} \text{ n} \cdot \text{cm}^{-2} \cdot \text{s}^{-1}$ or full power, $1 \times 10^{12} \text{ n} \cdot \text{cm}^{-2} \cdot \text{s}^{-1}$ )	
4. Coolant temperature rise within the range of (10°C to 15°C) for half power operation and (18°C to 25°C) for full power operation	
5. Reactor shutdown after operation (shutdown checks followed)	

Reactor Power (kW) or Neutron Flux ( $\text{n} \cdot \text{cm}^{-2} \cdot \text{s}^{-1}$ ) of operation: ...

Initial Inlet coolant temperature (°C): .....

Maximum Inlet coolant temperature (°C): .....

Corresponding Outlet coolant temperature (°C): .....

Corresponding Coolant temperature rise (°C): .....

Estimated Thermal-hydraulic Reactor Power (kW): .....

Sample Transfer Pressure (MPa): .....

Maximum Gamma Ray Dosimeter Value ( $\mu\text{Gy/hr}$ ): .....

Purpose of reactor operation: .....

Remarks/Observations: .....

### Form 6. Fault Detection and Rectification Description

Our ref: QAQC/NRRC/RM/INT/.....

FAULT NUMBER/YEAR: ...../.....

Date of fault detection

Fault description	Description of actions taken to rectify/correct fault detected	Effect of fault on Reactor Operation
Brief description of fault detected:	Brief description on replacement/repair of components:	Number of days, weeks or months the reactor was out of operation:
How was the fault detected?	Brief description of any other actions taken:	Any other effect:
Electrical/electronic components and/or reactor components affected:		
Fault Ref. No.:	Time spent on replacement/repair of components (time spent on fault rectification):	

Remarks/Observations: .....

**4. Comparison of Control Console Flux, Reactor Core Flux, and Elemental Concentration Determination Flux**

This QA/QC programme is carried out to ensure that the control console flux (power) setting produces almost the same reactor power (flux) in the core, and the elemental concentration determination flux is almost equal to the control console flux or reactor core flux, as shown in the Table (2). Further theoretical neutron flux calculations are made using MCNP code and the resulting values are compared with the experimental data obtained in Table (2).

**Table (2): Comparison of Control Console Flux, Reactor Core Flux, and Elemental Concentration Determination Flux**

Control console flux/power	Reactor core flux/power	Elemental concentration determination flux/power

Equation (1) is flux dependent reactor power equation used to calculate reactor power (P) corresponding to particular neutron flux  $\phi$ .

$$P = 3.4 \times 10^{-8} \phi \tag{1}$$

Equation (2) is used to calculate the real/actual reactor power, kW (P) using thermal hydraulic parameters (inlet coolant temperature, °C ( $T_i$ ), and temperature difference between the inlet and outlet orifices, (°C) ( $\Delta T$ )).

$$P = \exp \left[ \left( \ln \frac{\Delta T}{6.81 T_i^{-0.35}} \right) (0.59 + 0.0019 T_i)^{-1} \right] \tag{2}$$

The equivalent 2200 m/s thermal flux ( $\phi_{th}$ ), in which a monitor sample such as Zr or Au is irradiated, can be calculated from equations (3).

$$\phi_{th} = \frac{R_s - F_{cd} R_{s,cd}}{g \sigma_{th} G_{th}} \tag{3}$$

where  $R_s$  and  $R_{s,cd}$  are the reaction rate per atom of bare and Cd covered isotope irradiation, given

by equations (4, 5).

$$R_s \text{ or } R_{s,cd} = \frac{(A_{sp} \text{ or } A_{sp,cd}) F_g M}{\theta N_A Y \epsilon_p} \tag{4}$$

$$A_{sp} \text{ or } A_{sp,cd} = \frac{N_p / t_m}{WSDC} \tag{5}$$

where  $A_{sp}$ ,  $A_{sp,cd}$  are the specific activities obtained after bare and cadmium covered isotope irradiation,  $N_p$  the net



number counts under the full-energy peak collected during measuring time,  $t_m$ ,  $W$  the weight of irradiated element,  $S = 1 - e^{-\lambda t_{irr}}$  the saturation factor with  $\lambda$  being the decay constant,  $t_{irr}$  the irradiation time,  $D = e^{-\lambda t_d}$  the decay factor correcting for decay time,  $C = (1 - e^{-\lambda t_{irr}})/\lambda t_m$  the measurement factor correcting for decay during the measuring time  $t_m$ ,  $M$  the atomic weight,  $\theta$  the isotopic abundance,  $N_A$  the Avogadro's number,  $\gamma$  the absolute gamma-ray emission probability,  $\varepsilon_p$  the full-energy peak detection efficiency, and  $F_g$  the correction factor for gamma-ray attenuation,  $g$  is the correction for departure from  $1/v$  cross-section behavior,  $G_{th}$  the self-shielding factor for thermal neutrons,  $\sigma_{th}$  the thermal neutron cross section,  $\phi_{th}$  the thermal neutron flux, and  $F_{Cd}$  the cadmium correction factor [12 - 14].

## 5. CONCLUSION

Quality Assurance and Quality Control programmes involving reactor operation and neutron activation analysis carried out at Ghana Research Reactor-1 (GHARR-1) facility have been presented in this work. QA/QC forms for monitoring activities of reactor operation and maintenance, and neutron activation analysis have been presented. These QA/QC monitoring forms are used for the implementation of Quality Assurance and Quality Control programmes in the GHARR-1 facility. Quality Assurance and Quality Control programme implementation in the GHARR-1 facility is important for the safety of workers as well as the public who visit the Reactor Centre, and is also important for producing reliable NAA reports of various geological, biological and liquid samples analyzed for their elemental concentration determination (Qualitative and Quantitative analysis). Implementation of the Quality Assurance and Quality Control programmes in the GHARR-1 facility also helps to prolong the life span of the Research Reactor Facility.

To conclude, the implementation of the Quality Assurance and Quality Control programmes in the GHARR-1 facility presented in this work would be helpful to the readers as well as the Research Reactor facilities that perform Qualitative and Quantitative analysis using Miniature Neutron Source Reactor (MNSR).

## CONFLICT OF INTEREST

There is no conflict of interest concerning the publication of this work.

## REFERENCES

- [1] Shitsi, E., Amoah, P., Ampomah-Amoako, E., Odoi, H.C. (2020) Steady State Safety Analysis of Ghana Research Reactor -1 (Gharr-1) with LEU Core. *Journal of Thermal Science and Engineering Applications*, Vol. 12 / 054501-1.
- [2] Amoah, P., Shitsi, E., Ampomah-Amoako, E., Odoi, H.C. (2020) Transient Studies on Low Enriched Uranium (LEU) Core of Ghana Research Reactor -1 (GHARR-1). *Nuclear Technology* Volume 206, 1615–1624.
- [3] IAEA (2018) IAEA Safety Glossary Terminology Used in Nuclear Safety and Radiation Protection, International Atomic Energy Agency, Vienna.
- [4] IAEA (2013) Implementation of a Management System for Operating Organizations of Research Reactors, IAEA Safety Reports Series No. 75, International Atomic Energy Agency, Vienna.
- [5] IAEA (2009) The Management System for Nuclear Installations, IAEA Safety Guide No. GS-G-3.5, International Atomic Energy Agency, Vienna.
- [6] IAEA (2016) Safety of Research Reactors, IAEA Specific Safety Requirements No. SSR-3, Vienna.
- [7] IAEA (2016) Leadership and Management for Safety, IAEA General Safety Requirements No. GSR Part 2, International Atomic Energy Agency, Vienna.
- [8] IAEA (2010) Licensing Process for Nuclear Installations, IAEA Safety Standards Series No. SSG-12, International Atomic Energy Agency, Vienna.
- [9] IAEA (2005) Safety of Research Reactors, Safety Requirements No. NS-R-4, International Atomic Energy Agency, Vienna.
- [10] IAEA (2010) Governmental, Legal and Regulatory Framework for Safety, General Safety Requirements Part 1, No. GSR Part 1, International Atomic Energy Agency, Vienna.
- [11] ISO 9001: 2015 (2015) A Complete Guide to Quality Management Systems published by Itay Abuhav, Amazon Company, Seattle, Washington, USA.
- [12] Sogbadji, R. B. M., Nyarko, B. J. B., Akaho, E. H. K., Abrefah, R. G. (2011) Determination of Neutron Fluxes and Spectrum Shaping Factors in Irradiation Sites of Ghana's Miniature Neutron *Arab J. Nucl. Sci. Appl.*, Vol. 56, 2, (2023)

- Source Reactor (MNSR) by Activation Method after Compensation of Loss of Excess Reactivity. *World Journal of Nuclear Science and Technology*, 1, 50-56
- [13] Karandag, M., Yucel, H., Tan, M., Ozmen, A. (2003) Measurement of Thermal Neutrons and Resonance Integral for  $^{71}\text{Ga}(n,\gamma)$   $^{72}\text{Ga}$  and  $^{75}\text{As}(n,\gamma)$   $^{76}\text{As}$  by using  $^{241}\text{Am}$ -Be Isotopic Neutron Source. *Nuclear Instruments and Methods in Physics Research A* 501, pp. 524–535.
- [14] Sogbadji, R.B.M., Nyarko, B.J.B., Akaho, E.H.K., Abrefah, R.G. (2010) Determination of thermal neutron cross-section and resonance integral for the  $^{75}\text{As}(n,\gamma)$   $^{76}\text{As}$  reaction by activation method using  $^{55}\text{Mn}(n,\gamma)$   $^{56}\text{Mn}$  as a monitor. *Nuclear Engineering and Design* 240, 980–984.