

Journal of Soil Sciences and Agricultural Engineering

Journal homepage & Available online at: www.jssae.journals.ekb.eg

Influence of Binding Materials on the Main Quality Parameters of Biomass Pellets Produced from Corn Stover

Rowyda Awad^{1*}; G. M. ElMasry¹ and S. A. M. Abd El-Azeem²

¹Department of Agricultural Engineering, Faculty of Agriculture, Suez Canal University, 41522 Ismailia, Egypt.

²Department of Soil and Water, Faculty of Agriculture, Suez Canal University, 41522 Ismailia, Egypt.



Cross Mark

ABSTRACT

Biomass pelletization is recently growing as a relevant alternative for the utilization and management of corn stover. The production of high-quality corn stover pellets is the most important aspect to focus on. Therefore, the purpose of this study was to investigate the effectiveness of using three types of binders in corn stover pelletizing process and on the quality properties (moisture content, water absorption capacity, ash content, energy content, unit density and durability index) of pellets produced. A pelletizing unit was developed and manufactured in a local workshop to produce durable and densified pellets, then the effect of three types of binders (protein, fiber and starch) were investigated. Corn stover was first chopped and pre-conditioned and then compressed into pellets inside the pelletizing prototype. The obtained results revealed that adding protein as a binder significantly improved the pellets' quality parameters. The results revealed that pellets produced from corn stover mixed with protein as a binding agent had the best quality characteristics having the lowest moisture content of 10.9 %, the highest unit density of 15.8 kg m⁻³ and the highest durability index of 99% compared with pellets produced from either starch or fibre or with pellets produced without a binding material (control).

Keywords: Corn stover, pelletization, pellets quality, durability index.

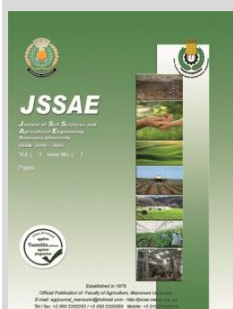

INTRODUCTION

Biomass is related to living and newly dead biological substances, which can be used as energy fuel, as well as a biodegradable waste which can be combusted as fuel (Karkania *et al.*, 2012). Nevertheless, the use of some types of biomass in the production of energy is restricted by their low density. The density of agricultural straws and grasses ranges between 80-150 kg m⁻³ and 150-200 kg m⁻³, respectively for wood biomass. For a cost-effective use in energy production, these materials must be densified (Tumuluru *et al.*, 2010). Densification is a method for producing agricultural biomass in specific shape and density. Compression force is crucial in densifying different powders or grinds particles (Mani *et al.*, 2004). Densified biomass quality depends on the number of process variables, such as diameter, die, pressure, binding and biomass preheating (Tumuluru *et al.*, 2014).

The physical, chemical, biochemical and structural quality characteristics of densified biomass are critically important during densification processes to obtain homogenous and durable pellets. The densified biomass quality is based on the feedstock composition, starch, protein, fibre, fat, lignin, and extractives; the content of the feed moisture; the size and distribution of the feed particles; feed conditioning, feed temperature (preheating); binders added to the feed; and machine parameters which significantly impact densified product strength and durability. The quality of the resulting pellets assesses the efficiency of the pelletizers and determines if the compressive effect and water strength during storage and transport can be withstood by the pellets (Stelte *et al.*, 2011). On the other hand, pellet quality varies

with the mechanical parameters (compression force, temperature) of biomass pelletizing unit and with post-production conditions (cooling and storage). Also, moisture, particle size, steam conditioning/preheating temperature and addition of binders are some of the factors affecting the durability of pellets (Ungureanu *et al.*, 2016). Moisture content is a significant parameter of the biomass material as it controls the friction between the compression channel in the pelletizing unit and the biomass material. The biomass moisture content is the binding agent and lubricant that enhances the contact region between the particles (Tabil and Sokhansanj 1996). In general, materials having greater moisture content and large particle sizes diminish the bulk and unit density, meanwhile, greater process temperatures and pressures, improve the unit and bulk density (Mani *et al.*, 2006).

During pelletization, the existence of liquid-like water causes interfacial and capillary pressures and thus increases particle binding. The power of the bond is due to adverse capillary pressure and fluid surface tension. The existence of heat and humidity gelatinizes and leads to better binding in the densification of the starch-rich biomass (Thomas *et al.*, 1998). High pressure during densifying biomass may lead to biomass particles being crushed and cell structures opened and protein and pectin that act as natural binders exposed (Bilanski and Graham, 1984). Due to preheating or steam conditioning, intrinsic binders such as starch, lignin and protein are usually more active. Lignin enables to deform plastic at greater temperatures, making pellets more durable. Steam conditioning helps release natural binders and lubricants into the raw material and increases starch jellying and denaturation of protein and produces long-lasting and

* Corresponding author.

E-mail address: Rowydaawad2020@gmail.com

DOI: 10.21608/jssae.2023.179965.1120

hard pellets. Furthermore, the protein helps in increasing the densified products breaking force (Briggs, 1999).

The production of stable pellets with high density requires the optimal range of biomass moisture. In the defined temperature, water acts as a bonding agent, enhancing the bonds among material particles, helping to develop van der Waals forces, and increasing the area of contact among moister particles (Iroba *et al.*, 2014). Therefore, the main aim of this study was to investigate the influence of adding different binding materials (protein, starch and fibre) during the production of densified biomass pellets produced from corn stover using a locally-fabricated pelletizing prototype. The quality parameters of the resulting pellets will be evaluated regarding their moisture content, unit density, water absorption capacity, ash content, energy content, durability index.

MATERIALS AND METHODS

Raw material preparation

Corn stover residues of 12 % moisture content were collected, then chopped and grinded into fine particles, sieved to <1 mm and mixed with different binding agents (protein, fibre or starch) at a rate of 5 % from their original weight. Once the chopped corn stover mixed with the binding agent and preconditioned up to 20 % moisture content, it was then introduced inside a locally-fabricated pelletizing unit for producing durable and compressed pellets. The pelletizing unit was manufactured and developed in a local workshop at the 10th of Ramadan industrial city, Egypt. Preconditioning unit aimed to treat the chopped crop residues with forced hot steam to help in binding the main components of the residues. The preconditioning procedure helps to release and activate natural binders in the raw stover feed, activates the action of the artificial binders (control B0, starch B1, fibre B2 or protein B3) mixed with the feed, and promotes starch gelatinization and protein denaturation. The structures of the pellets, the preconditioning step helps in producing durable pellets.

Pelletizing prototype

The main function of the pelletizing unit was to produce a durable and hard pellet throughout specific

pelletizing mechanisms under different operational parameters. The pelletizing unit composed mainly of five parts (main frame, feeding hopper, compression unit, cutting unit and power transmission). The main components of the pelletizing unit are as follow:

a. Main Frame

The main frame was made from iron steel of 2 mm in thickness. It was shaped like a box with dimensions of 900, 720 and 1000 mm for length, width and height, respectively. Moreover, in the lower part of the frame, the power transmission unit was fixed. Pelletizer parts were assembled on the main shaft of the pelletizer. The main shaft was fixed in a vertical position and constructed by two bearings. The main shaft was connected to an electric motor (D-22934, Getriebebau NORD, Germany) via v-shaped belt and two pulleys.

b. Feeding hopper

As shown in Fig. (1) and Fig. (2), the feeding conical-shaped hopper made from iron steel of 2 mm in thickness and upper diameter of 400 mm and lower diameter of 250 mm was used to feed the chopped corn stover to the rest of the pelletizing unit.

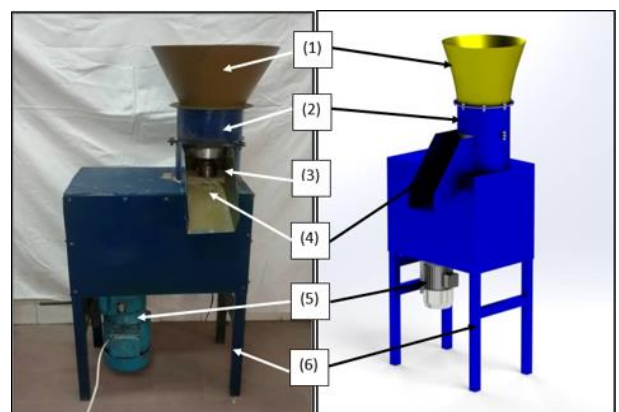

(1) Feeding hopper (2) Compression unit (3) Main shaft (4) Pellets outlet (5) Driven motor (6) Main frame

Fig. 1. The main components of the pelletizing unit from two different sides

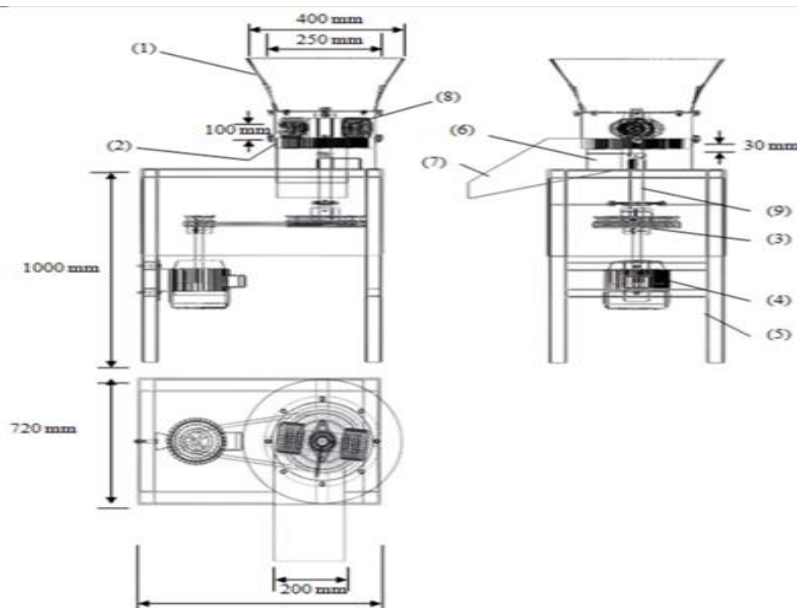

No.	Part name
1	Feeding hopper
2	Flat die
3	Power transmission unit
4	Electric motor
5	Main frame
6	Cutting knife
7	Pellets outlet
8	Compression rollers
9	Main shaft

Fig. 2. The developed pelletizing machine from (a) Elevation, (b) Side and (c) plan views.

c. Compression unit

The compression unit consisted of a flat die and two compressing rollers as shown in Fig. (3). The compressing rollers were responsible for compressing the feed and forming the raw material into pellets through the flat die cells. The flat die was made from stainless steel with a diameter of 250 mm and a thickness of 30, 40 or 50 mm. The flat die contains drilled-in cells with cell diameter of 6 mm, 8 mm or 10 mm. The flat die thickness and cell diameter were operated at these different levels to select the ideal combination for producing durable pellets. On the other hand, the compressing rollers consist of two rollers fabricated from hard iron steel and attached by conical bearings. The horizontal bar was carrying the two rollers fixed in the centre to a horizontal bar on the top main rotating shaft passing through the centre of the fixed flat die. Each roller was a cylinder in shape with 100 mm outer diameter, 50 mm inner diameter and 100 mm width. The rollers were fixed on the main shaft by keyway; the rollers were rotating in a stable motion around their horizontal bar that receives its motion from the main shaft. There was a clearance between the die and the rollers of 0.5 mm.

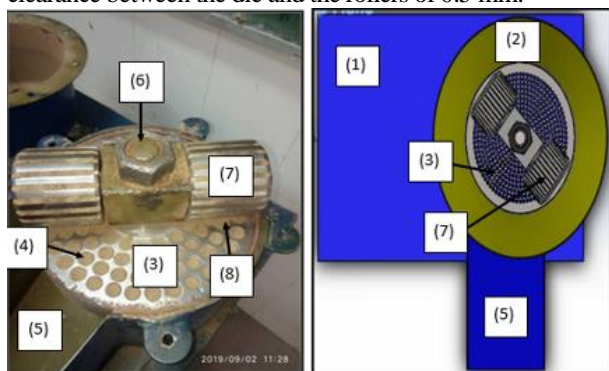

(1) Pelletizer prototype body (2) Feeding hopper (3) Flat die (4) Drilled in cells (5) Pellets outlet (6) Main shaft (7) Compression rollers (8) Clearance between the die and the rollers

Fig. 3. Components of the compression unit.

d. Cutting unit

The cutting unit used to cut the pellets expelled from the die cells consists of a sharp cutting knife and a scrapper plate. The cutting knife was fixed on a certain distance from the die to control the length of the expelled pellets, meanwhile, the scrapper plate was fixed on the main shaft to remove the resulting pellets towards the machine output and to avoid the accumulation of the pellets inside the machine. The cutting knife was made from stainless steel with dimensions of 125 mm length, 15 mm width and 2 mm thickness. The scrapper plate was made from stainless steel with dimensions of 125 mm length, 50 mm width and 2 mm thickness. Both the cutting knife and scrapper plate were fixed on the main shaft under the die by a cylindrical base that can change the distance between the upper blade of the knife and the lower side of flat die to control the length of the pellets

e. Power transmission unit

An electric motor of 4 hp (2.98 kW) supported with a gear box was utilized to drive the main shaft, the compression rollers, the cutting knife and the scrapper plate. The power from the motor was transmitted by means of two pulleys and V-shaped belt.

Experimental procedure of pellet production

The corn stover residues with moisture content of 12% were grinded into fine particles, sieved to < 1 mm and

then mixed with 5% binders (Protein, fibre or starch). The protein binder (lacto protein) consists of (70 % protein, 19% lactose, 6% moisture and 3% fat). The fibre binder is a soy fibre, consisting of 65.3% dietary fiber, 15.5% crude protein, 4.4% ash and 8.41% moisture. Meanwhile, the starch binder was a modified potato starch with E-number of 1422 (E-1422). Then the mixture was conditioned to 20 % moisture content via steaming process before being dropped in the feeding hopper of the pelletizing prototype. The mixture was then fed into the pelletizing prototype to be pressed by the compression rollers inside the drilled cells and the pellets expelled from the die were collected and evaluated.

Experimental variables

The resulting pellets were affected by different conditioning and operational parameters that may affect the overall properties of the pellets such as length, diameter, durability index, and hardness. Such parameters involved in this study were die thickness (T_D), cell internal diameter (d_c), cell external diameter (D_c) and cell length (L_c). The difference between T_D and L_c is 2 mm and the difference between D_c and d_c is 2 mm. All these parameters were operated under a constant diameter of the die (25 mm) and a constant cone height (Inclined depth) of the die cell ($I=2$ mm). These preliminary experiments were repeated for each binding material (Starch, fiber and protein) to identify the optimum values of these parameters that produce the optimum characteristics of the expelled pellets. Fig. (4) shows the key steps involved in the whole pelletizing process starting from raw corn stover through grinding, conditioning and pelletizing and ending cooling down and storage of the expelled pellets in relevant conditions.

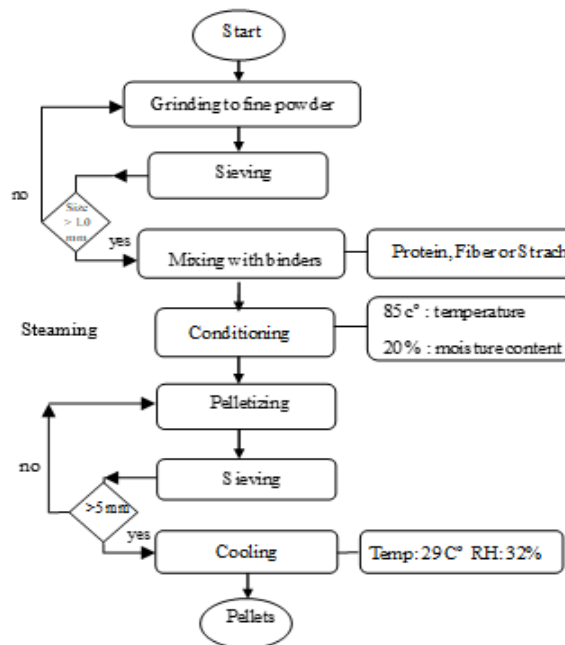

Fig. 4. The key steps involved in pelletizing process.

Measurements of main properties of the pellets

At each run of the pelletization process inside the designed pelletizing prototype, a sample of 500 g of the chopped, preconditioned corn residues mixed with a binder (starch, fiber or protein) was used. The sample was fed inside

the prototype and the resulting pellets were mechanically and physically evaluated. This procedure was repeated three times during which the pellets were collected manually from the pelletizer outlet, cooled using ambient air and then weighed to calculate the major properties to evaluate the efficiency of the pelleting parameters. First, the main dimensions and mass of the resulting individual pellets were determined to estimate the volume and density of the pellets under the effect of each applied pelletizing parameter.

Moisture content of the pellets

The moisture content of the pellets was estimated by drying the pellet samples in a drying oven (JSON-100, JSR, Korea) at 105 °C for 24 hours. The moisture content was determined as a wet-basis by estimating the mass of sample before and after drying (ASABE Standards, 2007) based on the following equation:

$$\text{Moisture content (wet basis), \%} = \frac{W_w - W_d}{W_w} \times 100 \quad (1)$$

where:

W_w : mass of wet sample, g.

W_d : mass of dry sample, g.

2.5.2. Water absorption capacity

Short-term exposure to rain or high humidity conditions during transportation and storage could adversely affect the quality of the densified pellets (Kaliyan and Morey, 2009). Therefore, water absorption capacity of the resulting pellets was measured. Each pellet was immersed in a flask filled with a definite quantity of tap water for 30 s (Lindley and Vossoughi, 1989) and the percentage of water absorbed by the pellets was calculated.

Ash content

Ash content is one of the main parameters for evaluating pellet quality. Therefore, ash content of the pellets was determined by burning the pellet samples in a muffle furnace (Vulcan, 3-130, Dentsply, USA) at 700 °C for 4 hours. A sample of 2 g were taken for each binder treatment and placed in the muffle furnace adjusted at 100 °C for 30 minutes and gradually increased by 100 °C every 30 minutes until reaching to 700 °C, then stayed for 4 hours at 700 °C. Afterwards, the samples were weighed to estimate the ash content.

Energy content

Energy content in pellets was estimated in cal/g by using a calorimeter device in the central laboratory of Faculty of Agriculture, Zagazig University. To estimate the energy content, 1 g from a pellet for each binder as well as the control treatment (pure corn stover without binder) was crushed and introduced inside a calorimeter.

Calorimeter is a device used to measure the internal energy in a substance. A simple calorimeter just consists of a thermometer attached to a metal container full of water suspended above a combustion chamber (Mandavgade, 2011). The basic principle is that the heat released by the combustion chamber increases the temperature of the water in a measurable way. The temperature change may then be used to calculate the heat change per mole of the combusted substance (Helmenstine, 2022). To find the energy of a substance, 1 g of the pellet was crushed and placed in the metal crucible in the combustion chamber in the calorimeter and the initial and final temperature (before the combustion starts and after the combustion finishes) were recorded.

Durability

The durability index of the resulting pellets was determined by using a mechanical vibrator supported with a sieve having a number of holes of 2 mm mesh size. A durable pellet should survive without losing fine particles from its mass when shacked on the mechanical vibrator. For determining the durability index of the pellets, a sample of 500 g of the pellets was placed over the sieve of the vibrator and shacked for 20 min. The fine particles passed through the sieve were collected and weighed. The total loss in the mass of the original sample was used to calculate the remaining mass of the sample. The percentage between the mass of the remaining pellets to the original mass of the pellets was used as an indication of the durability of the pellets using the following formula:

$$\text{Pellet durability} = \frac{M_{as}}{M_{bs}} \times 100 \quad (2)$$

where:

M_{as} : mass of the pellets after shacking, g.

M_{bs} : mass of the pellets before shacking, g.

Unit density of the pellet

The pellet diameter and length was measured with a digital calliper. Average values of diameter, length and mass were measured from 20 randomly selected individual pellets for each binder. Density of individual pellets was calculated from the average weight and volume using the following equation:

$$\text{Unit density of a pellet (g cm}^{-3}\text{)} = W_r / V_r \quad (3)$$

where:

W_r : mass of the individual pellet, g.

V_r : volume of the individual pellet, cm³

Volume of the individual pellet was calculated considering that the pellet is a cylinder with a certain diameter (D) and length (L).

Statistical analysis

Analysis of variance (ANOVA) was performed using a general linear model by using SPSS 25.0 software (Version 25.0, IBM Inc., USA). Post hoc comparisons were also performed using the least significant difference (LSD) post hoc test at a statistical level of probability of $P \leq 0.05$.

RESULTS AND DISCUSSION

The experiments of producing pellets from corn stover using the developed pelletizing prototype were conducted on three specifications of the flat die that differs in die thickness and cell diameters (outer and inner diameters). Also, there were three types of binding materials and moisture content. In details, the experiments were conducted on die thicknesses of 30, 40 and 50 mm, drilled-in-cells diameters of 6 (8), 8 (6) and 10 (12) mm, raw material moisture contents of 10, 20 and 30 % and three different binding materials (control B0, starch B1, fibre B2 and protein B3.). All these variables were investigated and tested alternatively, with motor power of 4 HP and 120 rpm. Using these preliminary experiments, the following points were concluded:

- 1- The die thickness of 30 mm with cell diameter Dc(dc) of 12 (10) was the best die specification to obtain the highest productively of the pellets along with optimum shape in terms of regularity and smoothness. Meanwhile, a die thickness of 40 with cell diameter of 10 (8) and die thickness of 50 with cell diameter of 8 (6) caused severe swallow of the raw materials inside the die.

2- Moisture content of raw material of 20% was the best moisture level where the moisture content of 10% resulted in un-pelleted materials, whereas the moisture content of 30% resulted in irregular and disassembled pellets.

The preliminary experimental results of this study were very useful in the evaluation of pelletizer operating parameters. Hence, the best operating parameters were only investigated at different types of binding materials (control

B0, starch B1, fibre B2 and protein B3) to evaluate their influence on the overall quality of the pellets.

Pellets’ quality parameters

Different quality parameters of the pellets such as moisture content, water absorption capacity, ash content, unit density, durability and energy generated from the pellets were measured and calculated at different types of binding materials such as B0, B1, B2 and B3 and as illustrated in Table (1).

Table 1. Effect of different binders on the overall characteristics of the resulting pellets.

Binder	Moisture content(%)	Water absorption (%)	Ash(%)	Unit density(kg m ⁻³)	Durability(%)	Pellets energy(kJ kg ⁻¹)
B0	13.9 ^{a*} ± 0.48 ^{**}	44 ^a ± 3.95	66 ^a ± 0.35	12.9 ^d ± 0.26	97 ^c ± 0.31	335 ^b ± 0.0
B1	12.8 ^{ab} ± 1.56	25 ^b ± 1.50	54 ^b ± 1.14	13.4 ^c ± 0.29	98 ^b ± 0.07	451.1 ^a ± 0.0
B2	12.7 ^{ab} ± 1.52	11 ^c ± 3.25	48 ^c ± 1.55	14.4 ^b ± 0.18	97 ^c ± 0.29	451.1 ^a ± 0.0
B3	10.9 ^b ± 0.95	12 ^c ± 0.94	55 ^b ± 1.57	15.8 ^a ± 0.11	99 ^a ± 0.18	451.1 ^a ± 0.0

^{*}Different small superscripted letters in the same column indicate significant difference among binders at a significance level of $p \leq 0.05$ ^{**} The value refers to mean ± standard deviation

Pellet’s moisture content

Water acts as both a binding agent and a lubricant. Water helps developing van der Waals’ forces by increasing the area of contact between particles (Grover and Mishra, 1996). Consequently, moisture content can alter the property of the densified materials during pelletization process (Tabil and sokhansanj, 1996). It controls the starch gelatinization, protein unfolding, and fibre solubilization process during densification. Biomass with low moisture content has better densification (Kaliyan and Morey, 2009). The highest value of pellet moisture content of 13.9 % was obtained when no binder added to the raw materials. While the lowest recorded value of moisture content was 10.9% obtained when protein binder material was added to the raw material. This result agrees with that obtained by Obernberger and Thek (2004) who found that production of high-quality pellets is possible only if its moisture content is between 8.0 and 12.0% (w.b.), and water contents above or below this range would lead to lower quality of the pellets.

Moreover, Table (1) shows that the effect of protein inclusion as a binding material resulted in a substantial variation in pellet moisture content ($P \leq 0.001$). However, there was no discernible ($P \geq 0.63$) difference in moisture content between pellets that does not have binding material (B0) and those ones prepared by adding starch (B1) or fibre B2 as a binding material.

Pellet’s water absorption capacity

The capacity of the resulting pellets in absorbing water is extremely important criterion in evaluating the overall quality of such pellets. The results revealed that the pellets resulting from raw fine materials without adding binding agents (the control B0) had the highest water absorption capacity (44%) compared with those prepared by adding different binding agents (starch B1, fibre B2 or protein B3) and this result is in agreement with that reported by Hanshen *et al.* (2018). Therefore, the results shown in Table (1) revealed that a substantial difference ($P \leq 0.001$) in water absorption capacity of the pellets was observed between B0 and those received different binding materials (B1, B2 and B3) with lowest water absorption capacity values between pellets prepared from fibre (B2) and protein (B3) as binding materials, between which there was no significant difference ($P \geq 0.61$) in water absorption capacity.

Pellet ash content

The amount of ash in pellets is one of the most important combustion characteristics and quality indicators of the prepared pellets. Consequently, pellets with high ash content are generally not suitable for thermal conversion due to problems associated with ash removal, slagging, corrosion of equipment and deposit formation in the furnace (Rhen *et al.* 2007). Furthermore, higher ash content in the fuel usually leads to higher dust emissions and has an influence on the heat exchanger design, the heat exchanger cleaning system, and the dust precipitation technology (Hartmann and Lenz, 2013). Moreover, high ash content in the pellets may also result in high level of operating discomfort among homeowners when used for residential heating (Acda and Devera, 2014). Consequently, high ash content in pellets will decrease the stove efficiency, and the stove requires cleaning more often (Obernberger and Thek, 2004). In this study, when no binder (B0) was used as a raw material only, the pellet ash content reached its greatest value of 66%. Meanwhile, when fibre binder (B2) was added to the corn stover raw materials, the lowest value reported was 48 %. In general, the findings in Table (1) revealed that all types of binding material had a substantial ($P \leq 0.001$) effect in pellet ash content compared with control B0.

Pellet’s durability index

For success of the pelletization process, the quality of the densified materials must meet the user requirements and market standards. Therefore, testing the pellet to estimate the amount of damage that could be observed at the point of utilization in term of durability would help optimizing the feed material and densification equipment to produce high-quality pellets (Zafari and Kianmehr., 2013). Durability represents the solidity of the pellets during storage, handling and transportation. In addition, durability can be indicated to the ability of the pellets to bear the impact and friction resistances during handling, storage, and transportation processes. Higher durability of the pellets is desirable as it helps the pellets to retain their size and shape without any breakage or cracking during and after this process (Tumuluru *et al.*, 2010). Durability is typically used to evaluate the quality of produced pellets because it affects the safe usages of the pellets during storage and handling. In pellets industry, high durability means high quality and provides better handling during storage and transportation (Kaliyan and Morey, 2009). Table (1) showed that pellet’s durability index

reached the highest value of 99% when protein (B3) was used as a binding agent to the raw materials. This could be due to whey protein's substantial binding action, which causes increased cohesiveness among the particles, resulting in a higher durability index. The lowest recorded value of durability index of 97% was noticed at control treatment (B0) and when fiber (B2) was used as a binding agent and this result agrees with that reported by Oveisi-Fordiie (2011). This result revealed that the fiber binding material B2 has no effect in enhancing binding or durability properties as its effect was like the effect of natural lignin in the raw corn stover material itself.

Pellet's unit density

The results revealed that pellet density reached the highest value of 15.8 g cm⁻³ when protein was used as a binding agent with the raw corn stover; whereas the lowest recorded value was 12.9 g cm⁻³ when no binding agent was added to the raw material (i.e. the control B0). This could be due to the significant binding effect of whey protein leading to more cohesion among the raw material (Kumar *et al.*, 2009). The results shown in Table (1) indicated that there were high significant differences ($P \leq 0.001$) in pellets' single density between all types of binding agents.

Generated energy from pellet unit mass

In energy production aspects, low moisture content and high generated energy means high quality of the generated pellets. One of the most significant and important quality indicators is the amount of energy generated from pellets. Generated energy from a pellet reached the highest value of 451.1 kJ kg⁻¹ when binding materials (B1, B2 or B3) were used as binding materials. Meanwhile, the lowest value recorded of 335 kJ kg⁻¹ was obtained when no binder added to the raw material (B0). This result agrees with that reported by Handra *et al.*, (2018) who found that samples with binders gave calorific value higher than that of the samples without binders. Additionally, the results shown in Table (1) indicated that there was a highly significant difference ($P \leq 0.001$) in pellets energy between control pellets and those pellets prepared from different binding materials (B1, B2 or B3). However, there was no any significant difference ($P \geq 0.43$) between the effect of B1, B2 and B3 addition as a binding material. This could be due to the essential composition of all binding materials.

CONCLUSION

Densifying crop residues via pelletizing process has various beneficial impacts not only on the storage process but also on the handling and transportation costs. The ideal range of biomass moisture is necessary for the creation of stable pellets with high density. Water works as a bonding agent at the specified temperature, strengthening the bindings between material particles, assisting in the development of van der Waals forces, and expanding the surface area of contact between moister particles. Consequently, the primary objective of this study was to examine the effects of using various binding elements (starch, fiber and protein) during the manufacturing of densified biomass pellets made from corn stover by using a locally-manufactured pelletizing prototype. The study showed that the quality characteristics of the pellets were greatly enhanced by the use of protein as a binder. The findings showed that, in comparison to pellets produced from

either starch or fiber or control, pellets produced from corn stover mixed with protein as a binding agent had the best quality characteristics, having the lowest moisture content of 10.9%, the highest unit density of 15.8 kg m⁻³, and the highest durability index of 99%. These findings also include a knowledge and comprehension gap about the engineering factors related to the pelletizing prototype itself which affecting on the quality of pelletizing process. Future studies should look into how unique designing factors of the pelletizing prototype can increase the chance of producing more ideal pellets. Future studies could also look into the long-term effects of adding protein as a binder on the shelf life of pellets with storage.

REFERENCES

- Acda, M. N. and E. E. Devera. (2014). Physico-chemical properties of wood pellets from forest residues. *J. Tro. Fores. Sci.*, 26(4): 589-595.
- ASABE, D243.4 MAY03 (2007). Thermal Properties of Grain and Grain Products. ASABE standards, 593.
- Bilanski, W. K. and V. A. Graham. (1984). A viscoelastic model for forage wafering. *Trans. CSME, Can. Soc. Mech. Eng.*, 8(2): 70-76.
- Briggs, J. L.; D. E. Maier; B. A. Watkins and K.C. Behnke. (1999). Effects of ingredients and processing parameters on pellet quality. *Poult. Sci.*, 78: 1464-1471.
- Grover P. D. and S. K. Mishra. (1996). Biomass briquetting: technology and practices. Regional wood energy development program in Asia, GCP/RAS/154/NET, field document no. 46. Bangkok, Thailand: Food and Agriculture Organization of the United Nations.
- Handra, N.; A. Kasim and G. Santosa. (2018). Effect of binders on EFB bio-briquettes of fuel calorific value. *Inter. J. Adv. Sci.*, 8(4):1071.
- Hanshen, X.U.; W. Yang; Y. Haiping; Z. Youjian and H. Chen. (2018). Effect of binders on performance of corn stalk pellets. *IOP Conf. Series: Materials Science and Engineering* 382.
- Hartmann, H. and V. Lenz. (2013). Biomass energy heat provision in modern small-scale systems. *Renew. Ener. Sys.*, 382-431.
- Helmenstine, A. M. (2022). Calorimeter definition in chemistry. <https://www.thoughtco.com/definition-of-calorimeter-in-chemistry-604397>
- Iroba K. L.; L. G. Tabil; S. Sokhansanj and V. Meda. (2014). Producing durable pellets from barley straw subjected to radio frequency alkaline and steam explosion pretreatments. *Intern. J. Agric. Bio. Eng.*, 7(3):68-82.
- Kaliyan, N. and R. Morey. (2006). Densification characteristics of corn stover and switchgrass, Presented at the ASABE annual international meeting, July 9-12, 2006, Portland. 066174. USA.
- Kaliyan, N. and R. Morey. (2009). Factors affecting strength and durability of densified biomass products. *Biom. and Bioener.*, 33(3): 337-359. .
- Karkania, V.; E. Fanara and A. Zabaniotou. (2012). Review of sustainable biomass pellets production- a study for agricultural residues pellets' market in Greece, *Renew. and Sustain. Rev.*, 16: 1426-1436.

- Kumar, R.; N. Chandrashekar and K. K. Pandey. (2009). Fuel properties and combustion characteristics of lantana camara and eupatorium spp., *Curr. Sci.*, 97(6):930-935.
- Lindley, J. A. and M. Vossoughi. (1989). Physical properties of biomass briquettes. *Trans. ASAE*, (32):361-366.
- Mandavgade, K.; S. Jaju and R. Lakhe. (2011). Determination of uncertainty in gross calorific value of coal using bomb calorimeter. *Intern. J. of Measur. Techno. and Instru. Eng.*, 1(4):45-52.
- Mani, S.; L. G. Tabil and S. Sokhansanj. (2004). Evaluation of Compaction Equations Applied to Four Biomass Species. *Can. Biosys. Eng.*, 46: 355-361.
- Obernberger, I. and G. Thek. (2004). Physical characterisation and chemical composition of densified biomass fuels with regard to their combustion behavior. *Biomass and Bioener.*, 27:653-69.
- Oveisi-Fordiie, E. (2011). Durability of wood pellets (Thesis), University of British Columbia, Vancouver.
- Rhen, C.; M. Ohman; R. Gref and I. Wästerlund. (2007). Effect of raw material composition in woody biomass pellets on combustion characteristics. *Biomass and Bioener.*, 31: 66-72.
- Stelte, W.; J. K. Holm; A. R. Sanadi; S. Barsberg; J. Ahrenfeldt and U. B. Henriksen. (2011). Fuel pellets from biomass: The importance of the pelletizing pressure and its dependency on the processing conditions. *Fuel*, 90(11): 3285-3290.
- Tabil, L. G. and S. Sokhansanj. (1996). Process conditions affecting the physical quality of alfalfa pellets. *Americ. Soci. of Agric. Eng.* 12(3):345-350.
- Thomas, M.; T. van Vliet and A. F. B. van der Poel. (1998). Physical quality of pelleted animal feed 3. contribution of feedstuff components. *Anim. Feed Sci. Techno.*, 70:59-78.
- Tumuluru, J. (2014). Effect of process variables on the density and durability of the pellets made from high moisture corn stover. *Biosys. Eng.*, 119: 44-57.
- Tumuluru, J.; C. T. Wright; K. L. Kenny and J. R. Hess. (2010). A review on biomass densification technologies for energy application, Idaho National Laboratory.
- Ungureanu, N.; V. Vladut; S. Biris; M. Dinca; M. Ionescu; B. Zabava; M. Munteanu and I. Voicea. (2016). A review on the durability of biomass pellets. Politehnica University of Bucharest, Faculty of Biotechnical Systems Engineering, Romania.
- Zafari, A. and M. Kianmehr. (2013). Application of densification process in organic waste management. *Waste Management and Research: J. Sus. Circ. Econ.*, 31(7):684-91.

تأثير ثلاثة أنواع من المواد الرابطة على صفات مصبغات الكتلة الحيوية المنتجة من حطب الذرة

رويدا عوض خفاجي¹ ، جمال محمد المصري¹ و سامي عبد الملك عبد العظيم²

¹ قسم الهندسة الزراعية كلية الزراعة جامعة قناة السويس الإسماعيلية
² قسم الأراضي والمياه كلية الزراعة جامعة قناة السويس الإسماعيلية

الملخص

تعد عملية كبس الكتلة الحيوية في شكل مصبغات من العمليات المؤثرة في تقليل التكاليف. كما تعتبر المواد الرابطة من العوامل المؤثرة في إنتاج مصبغات جيدة. لذلك كان الغرض من هذه الدراسة هو التحقق من فعالية إضافة ثلاث أنواع من المواد الرابطة ودراسة تأثير كل مادة. لذلك تم تصنيع وحده كبس لحطب الذرة. في ورشة محلية في العاشر من رمضان وتم اختبار أدائها من خلال تجارب مبدئية لتحديد العوامل الهندسية المثلى لإنتاج مصبغات ذات جودة عالية. حيث تم تجفيف حطب الذرة حتى وصل إلى محتوى رطوبي 12% ثم تقطيعه وفرمه إلى أقطار أقل من 1 مم، ثم إضافة ثلاثة أنواع من المواد (الكتنرول، النشا، الألياف النباتية، البروتين) كمعاملات مختلفة. كما تم تعريض كل معاملة للبخار حتى وصل المحتوى الرطوبي إلى 20% و الحرارة إلى 85 درجة مئوية. وتم إنتاج المصبغات باستخدام وحدة الكبس وقياس صفات المصبغات من حيث المحتوى الرطوبي، قابلية التشرب للماء، نسبة الرماد، المتانة، كثافة الوحدة و محتوى الطاقة. ولقد أشارت النتائج إلى أن أقل قيمة للمحتوى الرطوبي 10.9% تم الحصول عليها في المصبغات التي استخدم فيها البروتين كمادة رابطة، كما تميزت تلك المصبغات بأقل قيمة لإمتصاص الماء هي ومعاملة الألياف النباتية وأقل نسبة رماد وأعلى كثافة للوحدة الواحدة 15.8 كجم / م³ وأكثرها متانة 99% مقارنة بالمعاملات الأخرى التي لم تستخدم مواد رابطة أو التي استخدم فيها الألياف النباتية أو النشا كمواد رابطة. كما أشارت النتائج إلى أن إضافة المواد الرابطة سواء النشا أو الألياف النباتية أو البروتين أعطت مصبغات ذات قيمة حرارية 451.1 كيلوجول/كجم مقارنة بالكتنرول 335 كيلوجول/كجم.