

# Calculations of Battery Capacity for an Electric Vehicle for two persons for operation in the new administrative capital

Amr Karam, Ahmed Ezz-Elregal

Automotive department, Military Technical College, Cairo, Egypt, amkaram59@gmail.com, ahmedezz89@gmail.com

Supervisor: Hisham M. Eltaher, Professor

Military Technical College, Cairo, Egypt, [hisham.kamel@mtc.edu.eg](mailto:hisham.kamel@mtc.edu.eg)

**Abstract-** The objective of this paper is to choose the suitable battery which gives us the required performance we need, the reason for using battery without of internal combustion engine is to reduce the emissions from the engines. Therefore, electric vehicles become an interesting choice due to their inherent advantages: quiet operation, zero operational emissions and comparatively lower maintenance costs.

We present the process of estimating the sizing electric batteries that can sufficiently power a small electric vehicle. We propose a micro electric vehicle that can seat only two persons and it is assumed that it will operate only in city. As an example, we selected the new administrative capital. In order to minimize the size, weight and cost of electric batteries, we designed the vehicle to be as compact, aerodynamic and light as possible.

We compare between some of batteries and choice the suitable one which reduce the total weight, suitable nominal capacity, low size and cost of the electric vehicle.

**Keywords** Electric vehicle –Battery capacity, micro car, vehicle design.

## I. Introduction

In recent years, greenhouse gas emissions and exhaust of natural fossil resources have become serious global issue. At the moment we, depend on energy made from the Earth's sources such as: gasoline, diesel, natural gas...etc. Internal combustion engine has several problems that affect the environment due to gas emission which come from these engines so that we exchange the engine by batteries. The advantages of the lithium-ion battery: Attractive cycle life, Extended safety performance, Wide operation temperature range, unrivalled high temperature performance, green energy without metal contaminant, High capacity, Steady output voltage, Little self-discharge, Double safety protection and withstanding very high level of vibrations and shocks.

## II. Selection type of battery

It is now clear that Li-ion batteries have won the race to electrify many forms of electric vehicles and the market is booming. There has been a flurry of investment in technology developers and battery manufactures over the past few years and electric vehicle OEMs continue to announce their electrification strategies. The market has been further buoyed by resilient electric vehicle sales during 2020, despite the ongoing disruption of covid-19. The market of Li-ion battery cells in electric vehicles is forecast to be worth nearly \$70 billion by 2026 and the report will break down forecasts for electric cars, buses, vans and the trucks along with an introduction to the drivers and restraints for these markets.

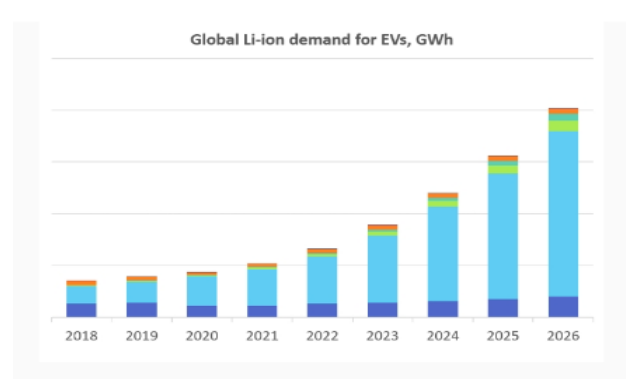

Fig. 1 The trend of demand on Lithium-ion batteries.

Nevertheless, currently, EV sales remain driven by policies and subsidies, which are being strengthened in the key markets of Europe and China and look set to be strengthened in the US under the Biden administration. In order to move

toward consumer driven, mass-market adoption, further improvements to Li-ion battery technology are desirable and this applies to many vehicle segments.

### III. Iteration of the battery that can be use

Frist we assume the total weight of the vehicle=500[kg], Then we calculate the require power which achieve the following characteristics the vehicle speed (V)=60[km/hr], The grade ( $\alpha$ )=10[deg.], weight of vehicle( $W_v$ )=400[kg], power=total -force\*vehicle speed , Total force=pf+ pv + p $\alpha$  where: Pf...rolling resistant force, pv....air resistant force, p $\alpha$ ....Grade resistant force.

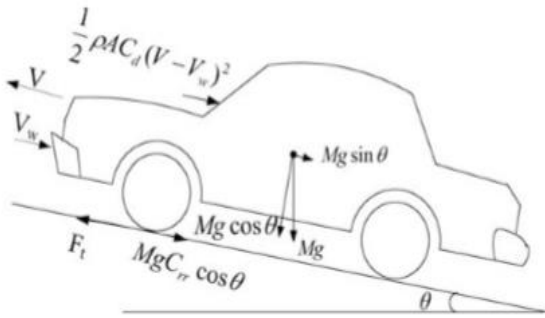

Fig. 2 Forces acting on vehicle during motion.

$$P_f = W_t * f * \cos(\alpha) = 500 * 10 * 0.02 * \cos(10) = 98.48 [N]$$

$$P_v = K F (V^2 / 13) = 0.25 * 0.48 * \{(60^2) / 13\} = 33.2 [N]$$

$$P_\alpha = W_t * \sin(\alpha) = 500 * 10 * \sin(10) = 868.24 [N]$$

Where:

$$K = 0.5 * \rho * C_d,$$

$$\rho \dots \text{Density of air} = 1.25 \left[ \frac{\text{kg}}{\text{m}^3} \right],$$

$C_d$  ... Drag coefficient,

$F$  ... frontal area =  $b * h$ ,  $b$  ... width,

$h$  ... Height,

$$W_t = w_v + w(\text{total batteries}),$$

$W$  total of batteries

$$= \text{no. of batteries} * W_{\text{battery}}$$

$$+ \text{Pack weight},$$

$$\text{Pack weight} = \frac{\text{Energy}}{S_b * F \text{ burden}},$$

$$S_b \dots \text{specific energy} = 243 \left[ \frac{\text{hr}}{\text{kg}} \right],$$

$F$  burden ... packing burden factor

Req. Battery Capacity	Energy	Req. no.	W1battery Weight	Pack weight	Total weight	
19	1.92	9.8958333	27	270	16.461	286.5
19	3.84	4.9479167	34	170	32.922	202.9
19	4.032	4.7123016	35	175	34.568	209.6
19	2.56	7.421875	35	280	21.948	301.9
19	5.12	3.7109375	43.6	174.5	43.896	218.4
19	5.376	3.5342262	43.6	174.5	46.091	220.6
19	8.192	2.3193359	72	216	70.233	286.2

(which represent thermal management system) = 0.48.

$$\text{Total force} = P_f + p_v + P_\alpha = 998.92 [N]$$

$$\text{power} = \text{Total force} * V = 998.92 * \{60 * (5/18)\}$$

$$= 16648.66 [\text{Watt}] \text{ Energy} = \text{power} * \text{time}$$

$$= 16648.66 / 1$$

$$= 16648.66 [\text{WH}] \quad \text{Required Battery capacity}$$

$$= \text{Energy} / 0.85 = 19586.66 [\text{WH}]$$

From the comparison between different batteries weight, we choose the smallest battery weight whose weight=202.9[kg], then we take this weight and calculate a new required power

$$P_f = W_t * f * \cos(\alpha) = 602.9 * 10 * 0.02 * \cos(10)$$

$$= 118.7 [N]$$

$$P_v = K F \left( \frac{V^2}{13} \right) = 0.25 * 0.48 * \left\{ \frac{60^2}{13} \right\} = 33.2 [N]$$

$$P_\alpha = W_t * \sin(\alpha) = 602.9 * 10 * \sin(10)$$

$$= 1046.9 [N]$$

$$\text{Total force} = P_f + p_v + P_\alpha = 1198.8 [N]$$

$$\text{power} = \text{Total force} * V = 1198.8 * \{60 * (5/18)\}$$

$$= 19980.4 [W]$$

$$\text{Energy} = \text{power} * \text{time} = \frac{19980.4}{1} = 19980.4 [\text{WH}]$$

$$\text{Required Batter capacity} = \frac{\text{Energy}}{0.85}$$

$$23506.3 [\text{WH}]$$

Req. Battery Capacity	Energy	Req. no.	W1battery Weight	Pack weight	Total weight	
24	1.92	12.5	27	351	16.461	367.5
24	3.84	6.25	34	238	32.922	270.9
24	4.032	5.952381	35	210	34.568	244.6
24	2.56	9.375	35	350	21.948	371.9
24	5.12	4.6875	43.6	218	43.896	261.9
24	5.376	4.4642857	43.6	218	46.091	264.1
24	8.192	2.9296875	72	216	70.233	286.2

From the comparison between different batteries weight, we choose the smallest battery weight whose weight=244.6[kg],

then we take this weight and calculate a new required power

$$P_f = Wt * f * \cos(\alpha) = 644.6 * 10 * 0.02 * \cos(10) = 126.9[N]$$

$$P_v = KF \left( \frac{V^2}{13} \right) = 0.25 * 0.48 * \left\{ \frac{60^2}{13} \right\} = 33.2[N]$$

$$P_\alpha = Wt * \sin(\alpha) = 644.6 * 10 * \sin(10) = 1119.3[N]$$

$$\text{Total force} = P_f + p_v + P_\alpha = 1279.4[N]$$

$$\text{power} = \text{Total force} * V = 1279.4 * \left\{ 60 * \left( \frac{5}{18} \right) \right\} = 21323.9[W]$$

$$\text{Energy} = \text{power} * \text{time} = \frac{21323.9}{1} = 21323.9[WH]$$

$$\text{Required Batter capacity} = \text{Energy}/0.85 = 25086[WH]$$

From the comparison between different batteries weight, we choose the smallest battery weight whose weight=261.9[kg], then we take this weight and calculate a new required power.

$$P_f = Wt * f * \cos(\alpha) = 661.9 * 10 * 0.02 * \cos(10) = 130[N]$$

$$P_v = KF \left( \frac{V^2}{13} \right) = 0.25 * 0.48 * \left\{ \frac{60^2}{13} \right\} = 33.2[N]$$

$$P_\alpha = Wt * \sin(\alpha) = 661.9 * 10 * \sin(10) = 1149.3[N]$$

$$\text{Total force} = P_f + p_v + P_\alpha = 1312.5[N]$$

$$\text{power} = \text{Total force} * V = 1312.5 * \left\{ 60 * \left( \frac{5}{18} \right) \right\} = 21876.2[Watt]$$

$$\text{Energy} = \text{power} * \text{time} = 21876.2/1 = 21876.2[WH]$$

$$\text{Required Battery capacity} = \text{Energy}/0.85 = 25737[WH]$$

From the comparison between different batteries weight, we choose the smallest battery weight whose weight=264.1[kg], then we take this weight and calculate a new required power

$$P_f = Wt * f * \cos(\alpha) = 664.1 * 10 * 0.02 * \cos(10) = 130.8[N]$$

$$P_v = KF \left( \frac{V^2}{13} \right) = 0.25 * 0.48 * \left\{ \frac{60^2}{13} \right\} = 33.2[N]$$

$$P_\alpha = Wt * \sin(\alpha) = 664.1 * 10 * \sin(10) = 1153.1[N]$$

$$\text{Total force} = P_f + p_v + P_\alpha = 1317.2[N]$$

$$\text{power} = \text{Total force} * V = 1317.2 * \left\{ 60 * \left( \frac{5}{18} \right) \right\} = 21953.2[W]$$

$$\text{Energy} = \text{power} * \text{time} = 21953.2/1 = 21953.2[WH]$$

$$\text{Required Battery capacity} = \text{Energy}/0.85 = 25827.4[WH]$$

Req. Battery Capacity	Energy	Req.no.	W1battery Weight	Pack weight	Total weight	
25	1.92	13.020833	27	351	16.461	367.5
25	3.84	6.5104167	34	238	32.922	270.9
25	4.032	6.2003968	35	245	34.568	279.6
25	2.56	9.765625	35	350	21.948	371.9
25	5.12	4.8828125	43.6	218	43.896	261.9
25	5.376	4.6502976	43.6	218	46.091	264.1
25	8.192	3.0517578	72	288	70.233	358.2

Req. Battery Capacity	Energy	Req.no.	W1battery Weight	#VALUE!	Pack weight	Total weight
25.8	1.92	13.4375	27	135	16.461	151.5
25.8	3.84	6.71875	34	170	32.922	202.9
25.8	4.032	6.3988095	35	175	34.568	209.6
25.8	2.56	10.078125	35	175	21.948	196.9
25.8	5.12	5.0390625	43.6	218	43.896	261.9
25.8	5.376	4.7991071	43.6	218	46.091	264.1
25.8	8.192	3.1494141	72	360	70.233	430.2

Req. Battery Capacity	Energy	Req.no.	W1battery Weight	Pack weight	Total weight	
25.7	1.92	13.385417	27	378	16.461	394.5
25.7	3.84	6.6927083	34	238	32.922	270.9
25.7	4.032	6.3740079	35	245	34.568	279.6
25.7	2.56	10.039063	35	350	21.948	371.9
25.7	5.12	5.0195313	43.6	261.6	43.896	305.5
25.7	5.376	4.780506	43.6	218	46.091	264.1
25.7	8.192	3.137207	72	288	70.233	358.2

LiFePO4 Battery for Golf Carts(OEM/ODM Acceptable!)					
TECHNICAL SPECIFICATION					
Model	Nominal Voltage	Nominal Capacity	Energy(KWH)	Dimension(L*W*H)	Weight(KG)
<b>36V</b>					
CP3650	38.4V	50Ah	1.92KWH	385*338*245mm	27KG
CP36100	38.4V	100Ah	3.84KWH	385*338*245mm	34KG
CP36105	38.4V	105Ah	4.032KWH	385*338*245mm	34KG
<b>48V</b>					
CP4850	51.2V	50Ah	2.56KWH	460*334*232mm	35KG
CP48100	51.2V	100Ah	5.12KWH	460*334*232mm	43.6KG
CP48105	51.2V	105Ah	5.376KWH	460*334*232mm	43.6KG
CP48160	51.2V	160Ah	8.192KWH	800*360*221mm	72KG
<b>72V</b>					
CP72100	73.6V	100Ah	7.36KWH	750*330*246mm	64KG
CP72105	73.6V	105Ah	7.728KWH	750*330*246mm	64KG
CP72160	73.6V	160Ah	11.77KWH	800*475*221mm	115KG

Research and development on batteries have increased the battery capacity, made it able to store more energy, and increased the vehicle mileage. To choose the suitable battery that can be use it, we give some of batteries with known its model, nominal voltage, nominal capacity, energy, dimensions and weight.

Finally, we have chosen the battery which achieve the most possible requirements that the voltage=48[V], the model CP48105, the nominal voltage=51.2[V], the nominal capacity=105[Ah], the energy= 5.376[KWH], the dimensions (460\*334\*232) [mm], the weight =43.6[kg]



Fig. 4 View of CAD model for vehicle packaging.

and the cost=109.99[\$] ,1721.5[EGP], So the total cost of the five batteries =8607.5[EGP]

We use the calculation to packaging the vehicle and determine its dimension and after final design we can determine the actual weight of body and chassis and luggage.

The final design of chassis as shown in **Error! Reference source not found..** The total weight 688.3 kg which include the weight of =180kg, luggage=20 kg, body and other compartment accessories =70 kg, chassis=91 kg, the energy required =156987.4 [W.H] The battery energy =26880 [W.H] The battery energy is sufficient to operate the vehicle.

#### IV. Conclusion

In this paper, we compare between combustion and electric vehicle and the advantages of each one. Then select the type of the battery and the global demand of Li-ion from 2018 to 2026 and observe the increase of this demand also why we chosen Li-ion battery. Made iteration to choose a suitable battery that gives us the required performance by give some of batteries known the nominal voltage, nominal capacity, energy, dimensions, weight and cost then compare between them by using excel sheet and calculate the power.

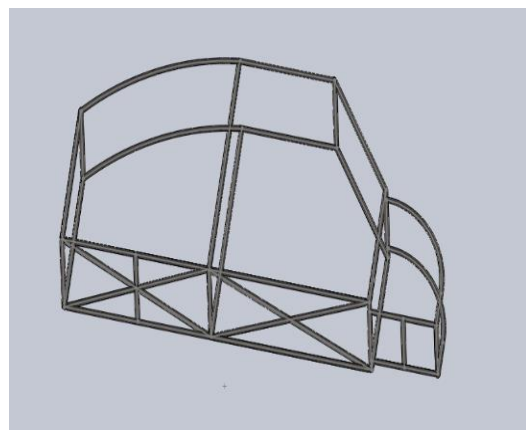
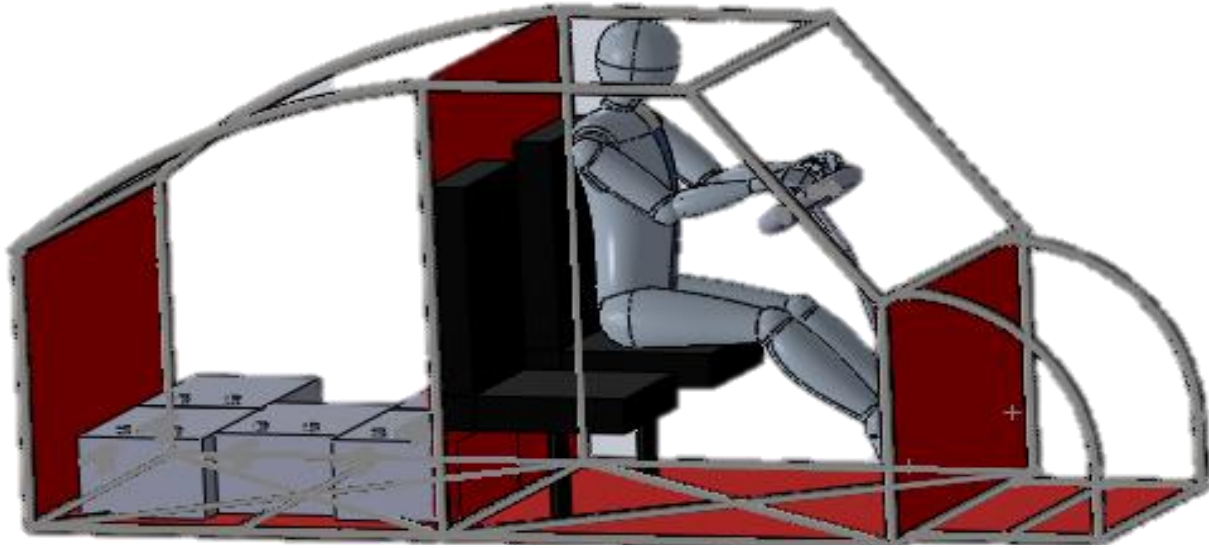

Fig. 3 View of CAD model for structural elements.



*Fig. 5 View of final design of the EV.*

### References

- [1] MTC Theory of automobiles book “to calculate the power, energy & the battery capacity”.
- [2] Sripad, S., & Viswanathan, V. (July 14, 2017). Performance Metrics Required of Next-Generation

- Batteries to Make a Practical Electric Semi Truck. *ACS Energy Letters*, 2, 7, 1669-1673.
- [3] Ali baba, <https://www.alibaba.com>