

**Military Technical College
Kobry El-Kobbah,
Cairo, Egypt**



**11th International Conference
on Electrical Engineering
ICEENG 2018**

OBOUR INSTITUTE SOLAR PANEL MICROCONTROLLER BASED SINGLE AXIS SUN TRACKING SYSTEM

O.A. MONEM*

ABSTRACT

Electricity plays a key role now in our daily lives but the energy sources of electric power has been used in abundance and so researchers were compelled to find an alternate source of power leading to the discovery of solar energy. Solar energy is rapidly employed as an important means of expanding renewable energy resources. Solar energy is inexhaustible and eco-friendly and can be converted into electricity using photovoltaic panels especially in the high solar illumination areas. These panels can be used in a fixed form or used in a solar tracking system employing single axis as well as dual axis. In the fixed configuration, efficiency is lower since the panels will be tilted in a particular angle whereas in the tracking system solar panels are made to move either in single axis or dual axis. In a single axis system the panel is moved in an east to west direction with respect to the sun and it has better efficiency than panels in fixed form [1]. This work present sun tracking system with single axi control. Obour Institute solar system is used for the experiment verification of this research. The recorded Efficiency improvement reaches around 20% higher than fixed system.

KEY WORDS

Solar array, Sun tracker, Fixed mount solar system, Single-axis sun tracker, Solar energy, Microcontroller, MPP; Maximum Power Point

1. Introduction

Sun tracking is one of the methods used to improve the efficiency of solar panel by producing more power with the same configuration through increasing the effective sun beams fallen on the solar panels by tracking the sun to make it nearly perpendicular to the solar panels that will lead to generate more power using the same solar panel size. Two types of sun tracking can be implemented; single axis and double axis sun tracking

* O.A. Monem, lecturer in communication and electronic department, Obour High Institute of engineering and technology Cairo, Egypt

[2]-[5]. The proposed method in this research is the single axis method based on microcontroller to control the tracking action done by DC motor through H-Bridge. The advantages of this method are Simplicity, cheap and flexible to be reprogrammed through microcontroller software development.

2. SYSTEM CONFIGURATION

The solar panel under study is used for feeding lighting and fan loads working at Energy Conversion lab. The proposed configuration consists of the existing solar system of 130 Watt and the proposed circuit to carry out the sun tracking. It consists of DC motor, H-bridge, Microcontroller, two power supplies 12 and 5 V. that used to energize the DC motor and the microcontroller. The power supply 12 voltage is used to energize the DC motor through L298 H-Bridge. The control of H-Bridge is carried out by PIC16F877A microcontroller which is programmed using micro C V.5.6.1 language and supplied by the 5 volts power supply. Fig. 1 shows the block diagram representing the system configuration. The system control is based on fixed step motor angle generated by the microcontroller and triggered by the photocell at sunrise and reset again at sunset.

3. Simulation

Simulation is used to save effort time and money, protect hardware of project, illustrate the stages of output and make sure the goal of project have been achieved. simulation for two circuit is built, the first one is stepper motor model and the second is DC motor by using proteus 7.8sp2.

Two circuits are simulated including the Microcontroller, DC motor, H-Bridge and the power supplies. The simulated circuit diagram is indicated in Fig 2 for stepper motor and Fig. 3 for DC motor models. The microcontroller software is constructed based on flow chart that describe the program sequential steps as shown in Fig. 4. Figure 5 represents the simulated motor angle plot versus time for 3 continuous cycles produced by the microcontroller.

4. Experiment results

Experiment results are recorded for both Fixed and sun Tracking systems. Two different measurement are recorded in two different days to validate the results at different temperatures. The first measurement taken each day is for I-V-P curves at different load levels by changing the resistance R at noon at 12:00 PM. The second measurement is the power versus time for both fixed and tracking systems from 8:00 AM to 5:00 PM recording current-voltage measurement and power-voltage curves.

4.1- First day results

The first day measurement was taken on 12th June. The ambient temperature recorded 35 ° C.

4.1.1- Current, Voltage and Power measurement

Table 1 lists the values of resistive loads, currents, voltages and power at 12:00 PM. Fixed system Current, power and voltage values are sketched for different values of resistive loads. Fig. 6 and Fig. 7 represent current-voltage and power voltage relations respectively showing the maximum power point; MPP with 18.7 Watt and maximum power point voltage of; VMPP = 10 volts.

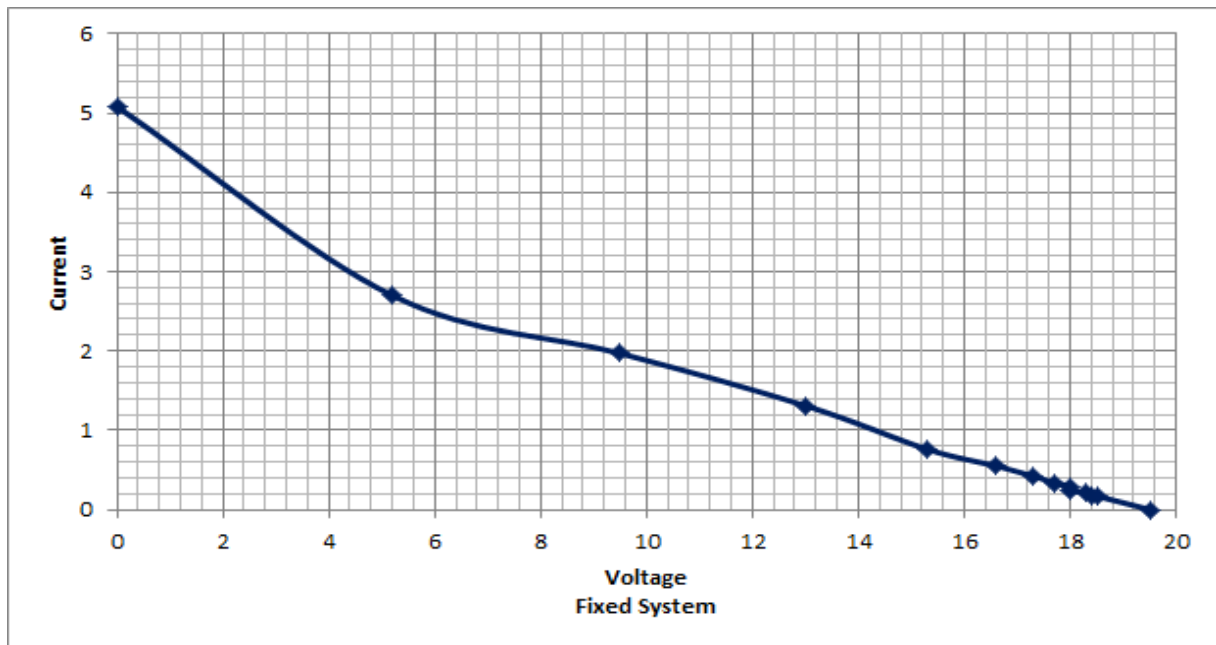

Fig: 6 I-V curve for fixed system measured on 12/6/2016

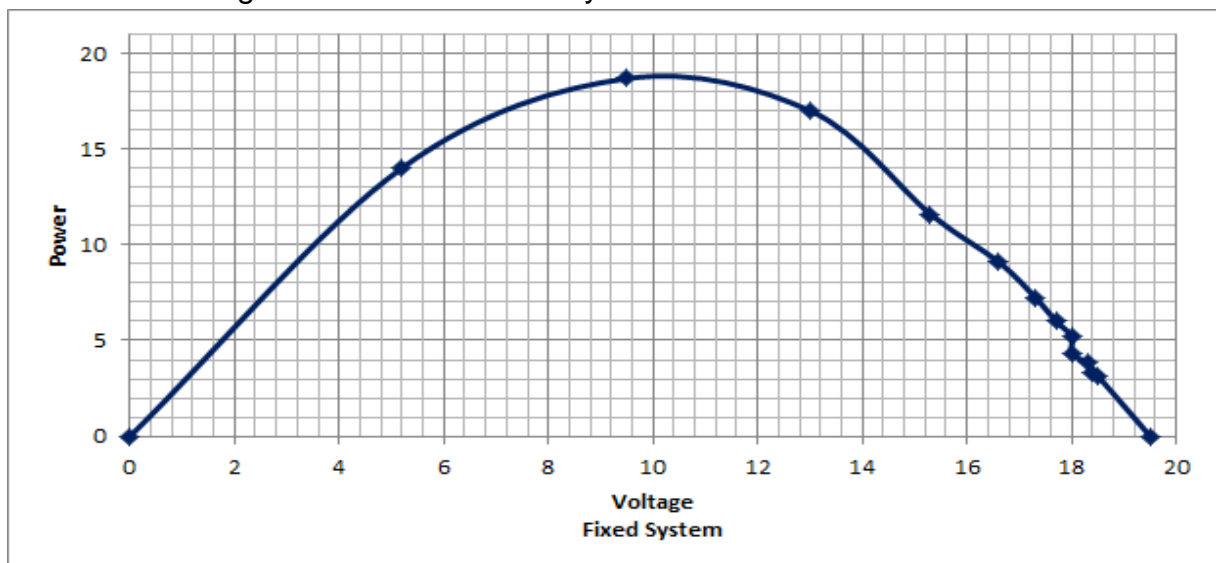

Fig 7 P-V curve for fixed system measured on 12/6/2016

The same measurements are taken for the tracking system. Fig. 8 and Fig. 9 indicate the I-V curve and P-V curves with maximum power of 20 Watt and VMMP of 10 volts.

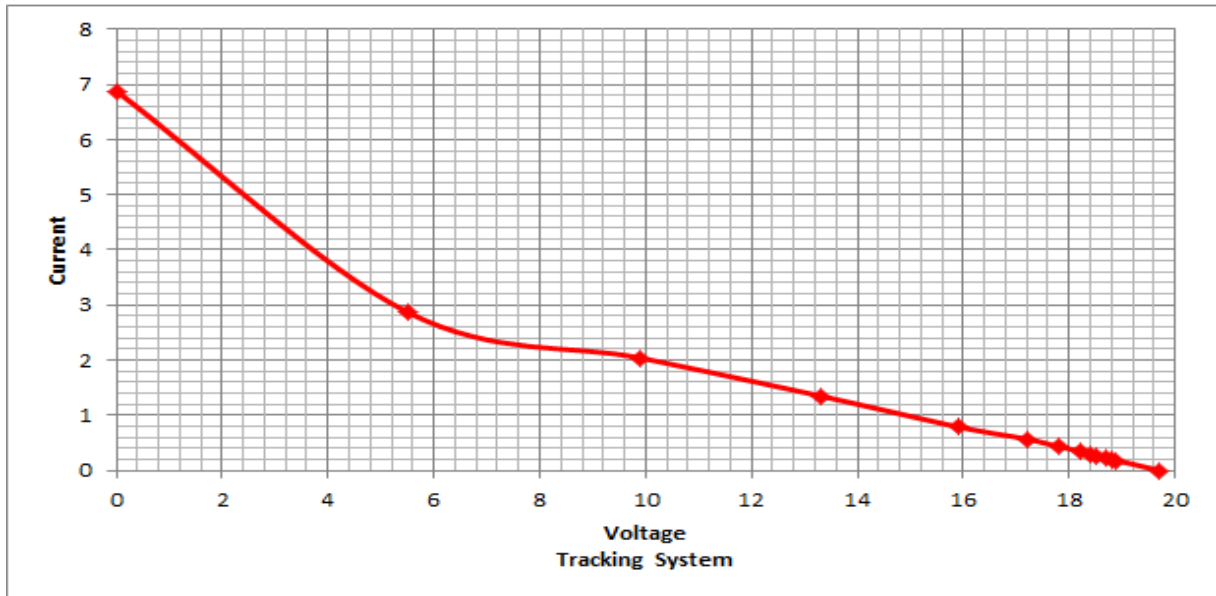

Fig: 8 I-V curve for tracking system measured on 12/6/2016

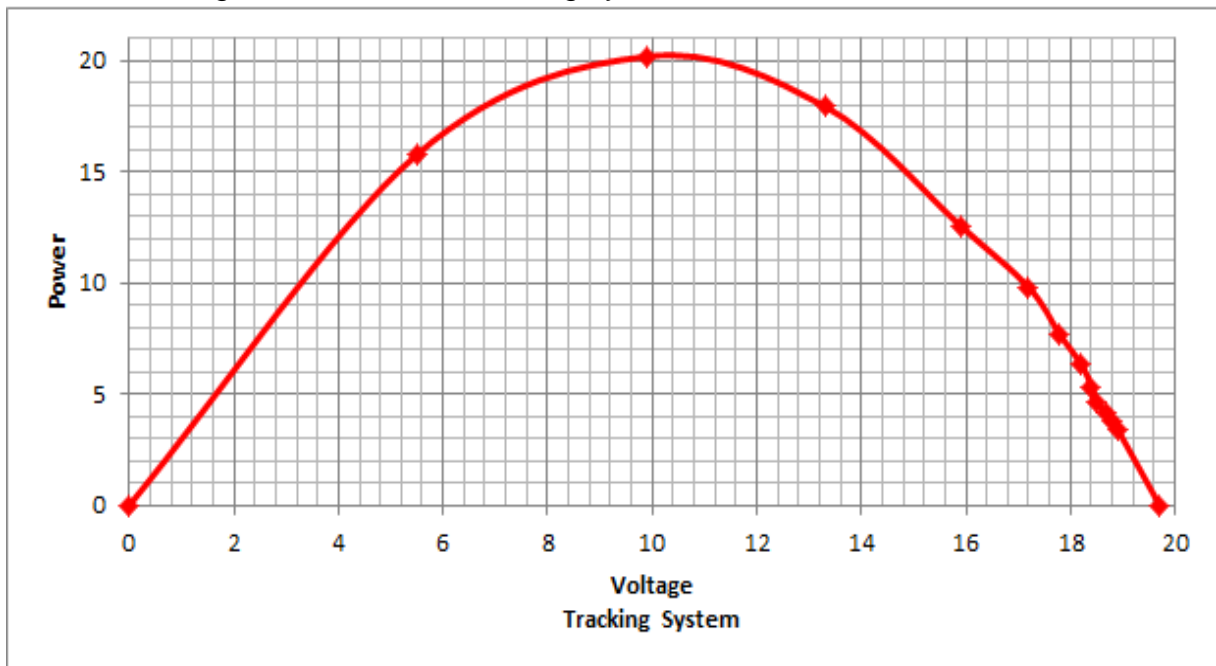

Fig 9 V-P curve for tracking system measured on 12/6/2016

Fig.10 shows comparison for the tracking system power versus fixed system power demonstrating that area under curve in tracking system is higher than fixed system which means higher power production by the same panels.

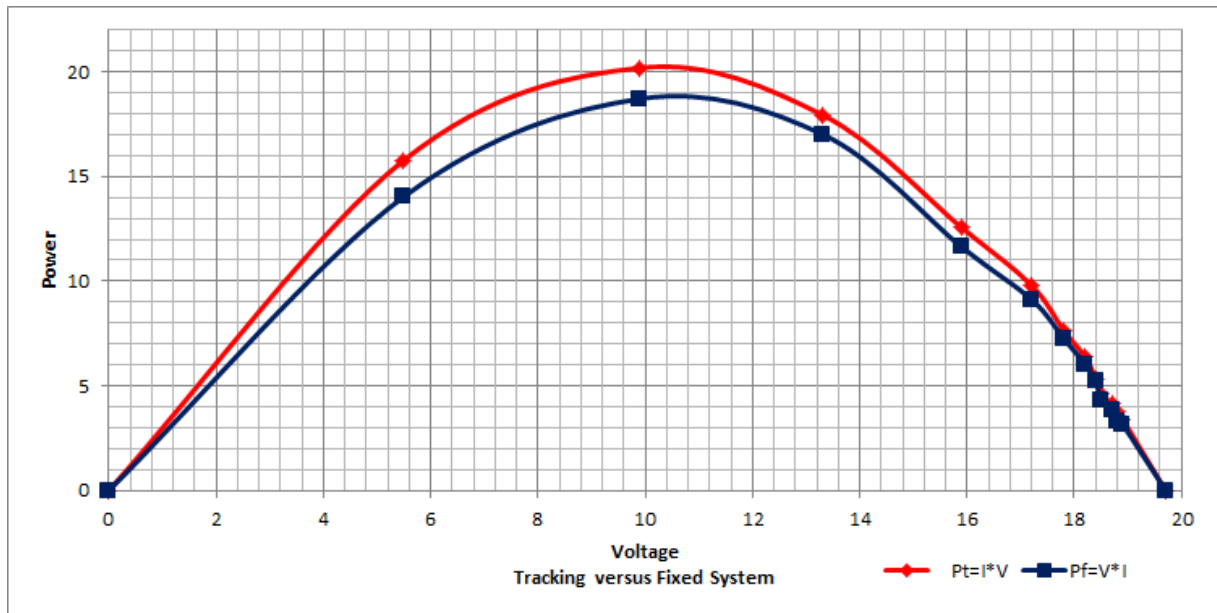

Fig 10 P-V curve for Tracking versus fixed system measured on 12/6/2016

4.1.2- Power versus time on 12-6-2016

This measurements are taken from 8:00 AM to 5:00 PM. Table 2 lists the power measured versus time for both systems.

Figure 11 and Fig. 12 indicate the individual curves with time for fixed and tracking respectively and Fig. 13 represents a comparison between fixed versus tracking with respect to time.

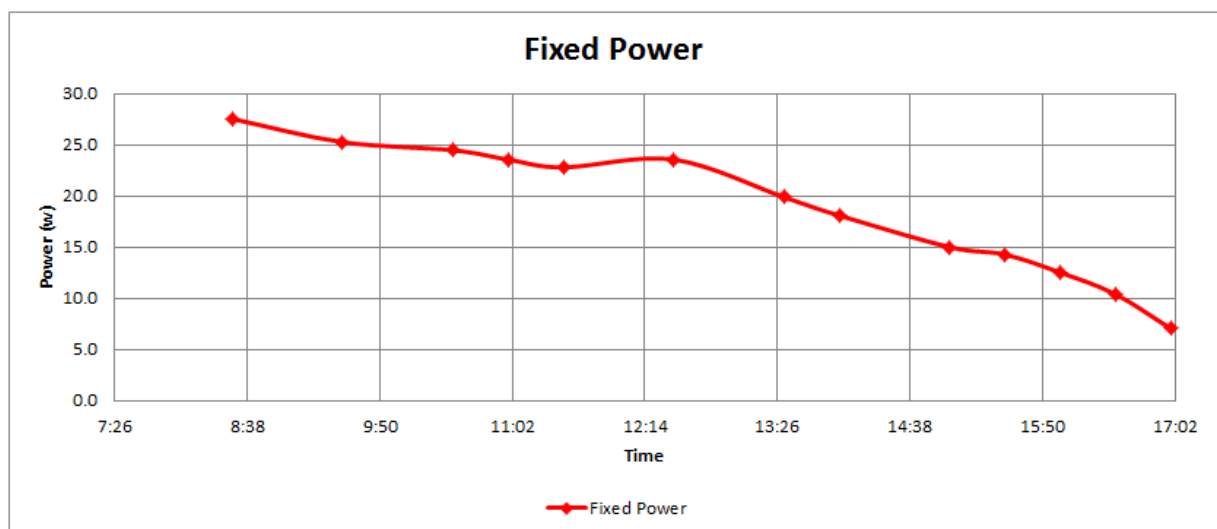

Fig 11 Power-time curve for fixed system measured on 12/6/2016

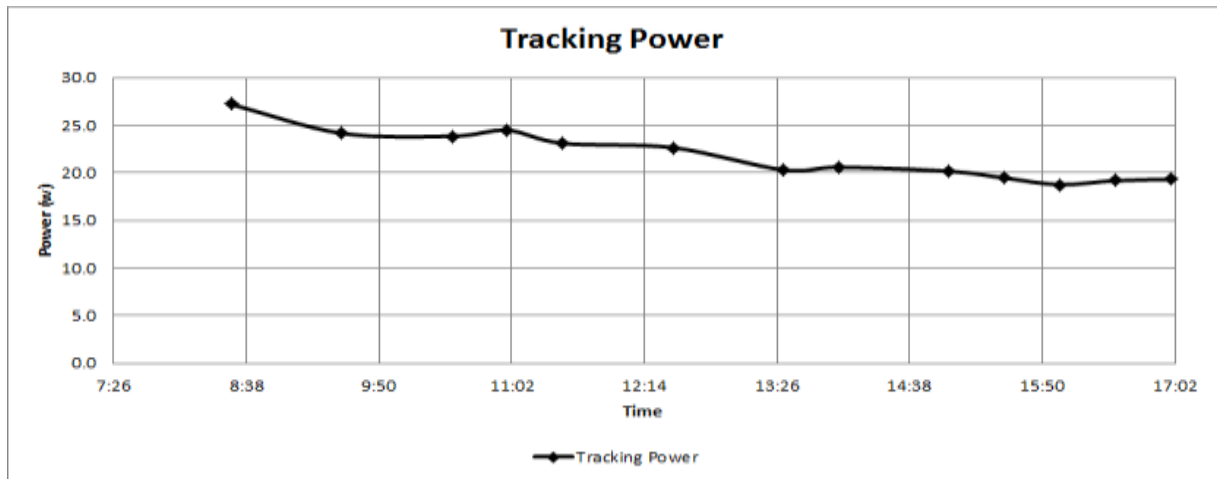

Fig 12 Power-time curve for tracking system measured on 12/6/2016

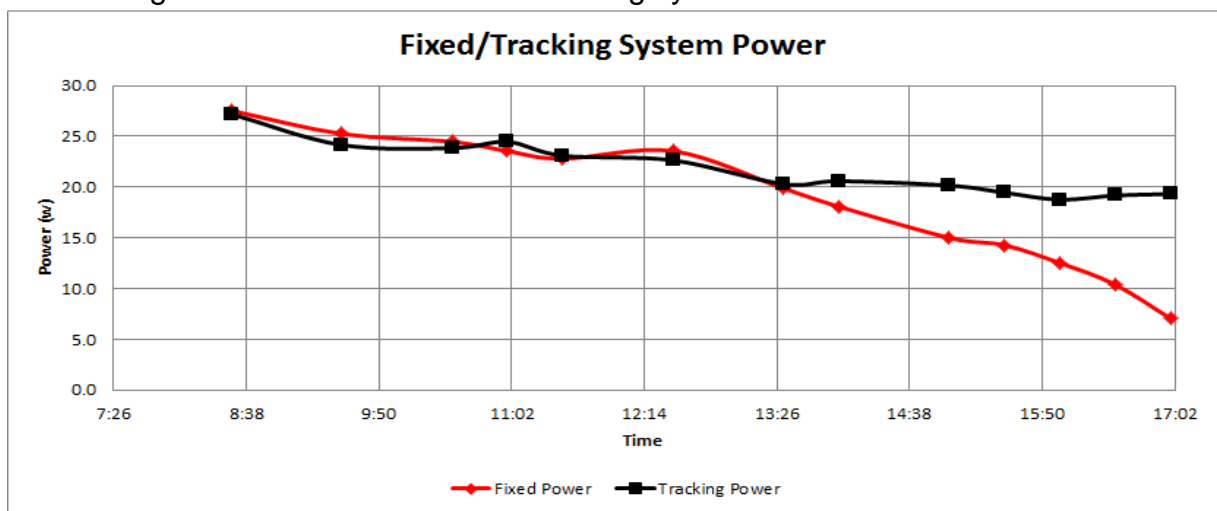

Fig 13 Power-time curve for fixed versus system measured on 12/6/2016

4.2- Second day results:

The second day measurement was taken on 14th June. The ambient temperature was 40^o C.

4.2.1-Current, Voltage and Power measurement

Table 3 lists the values of resistive loads, currents, voltages and power at 12:00 PM. Fixed system Current, power and voltage values are sketched for different values of resistive loads. Fig. 14 and Fig. 15 represent current-voltage and power-voltage relations respectively showing the maximum power point; MPP with 17.2 Watt and VMPP = 13 volts.

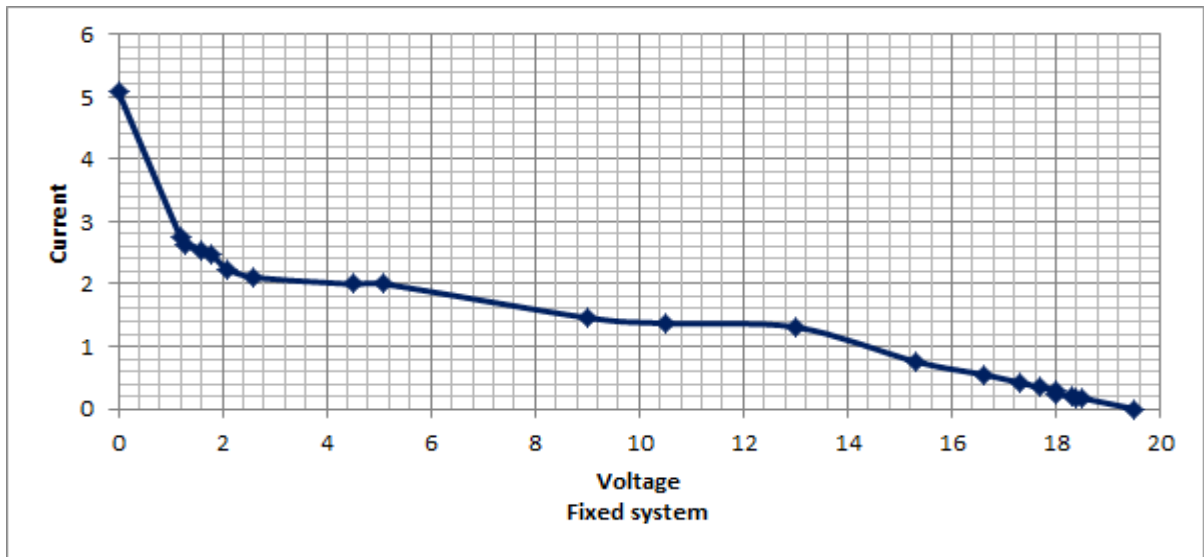

Fig 14 I-V curve for fixed system measured on 14/6/2016

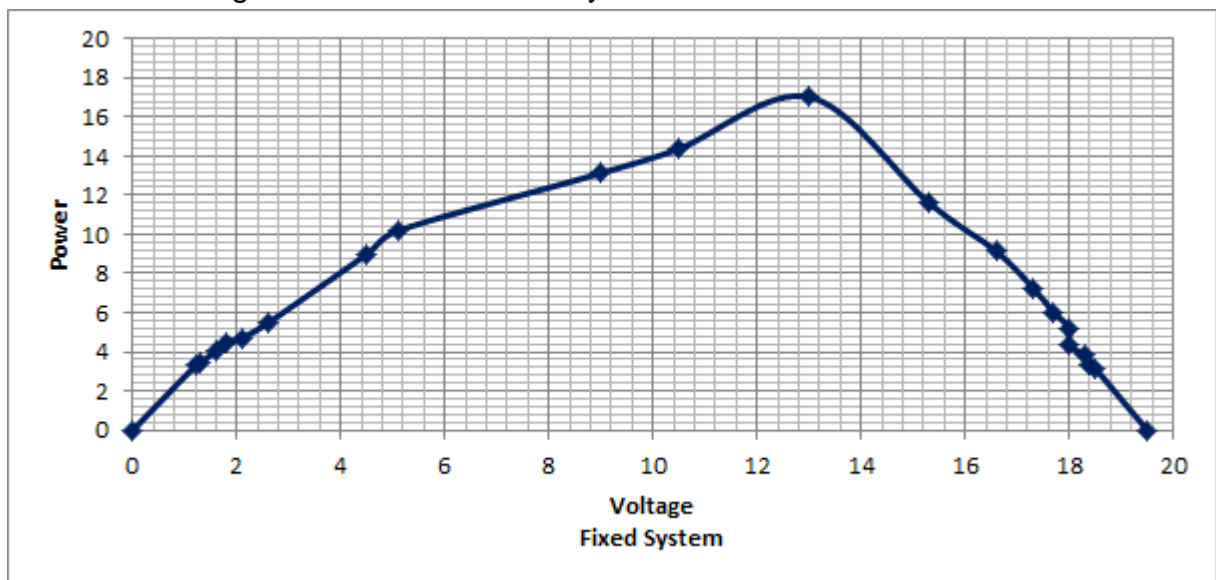

Fig 15 P-V curve for fixed system measured on 14/6/2016

The same measurements are taken for the tracking system. Fig. 16 and Fig. 17 indicate the I-V curve and P-V curves with maximum power of 18 Watt and VMMP of 13 volts.

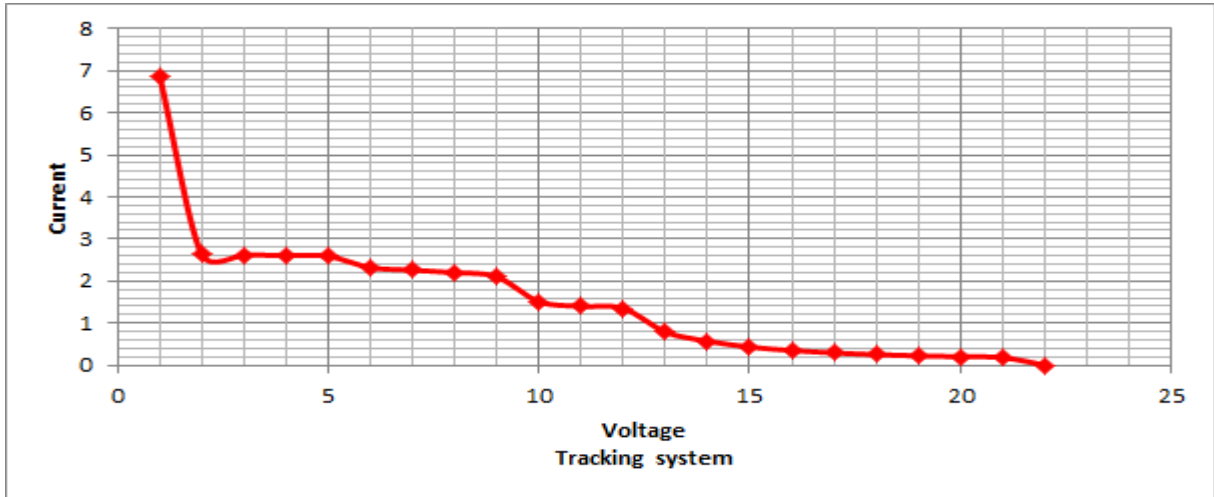

Fig 16 I-V curve for tracking system measured on 14/6/2016

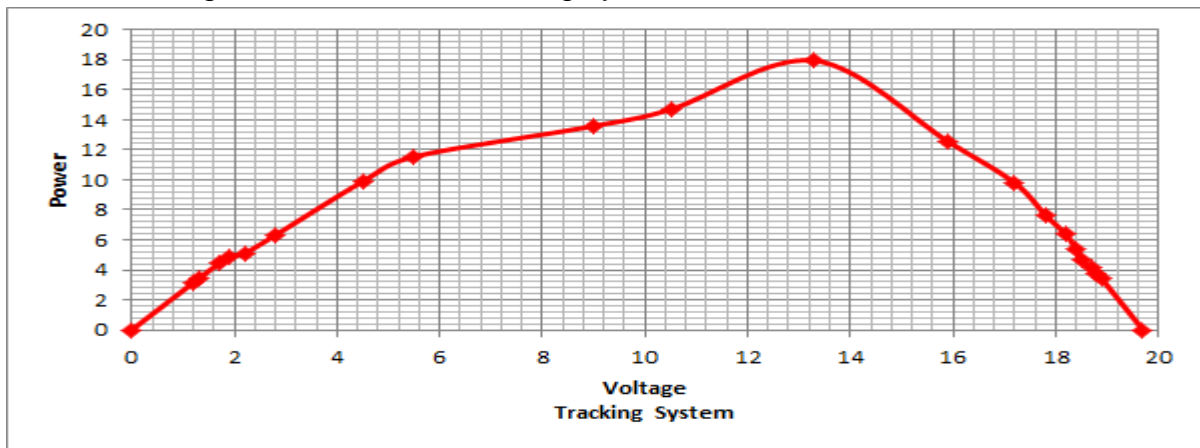

Fig 17 P-V curve for tracking system measured on 14/6/2016

Fig.18 shows the tracking system power versus fixed system power demonstrating that area under curve in tracking system is higher than fixed system which means higher power produced by the tracking system with the same solar panels.

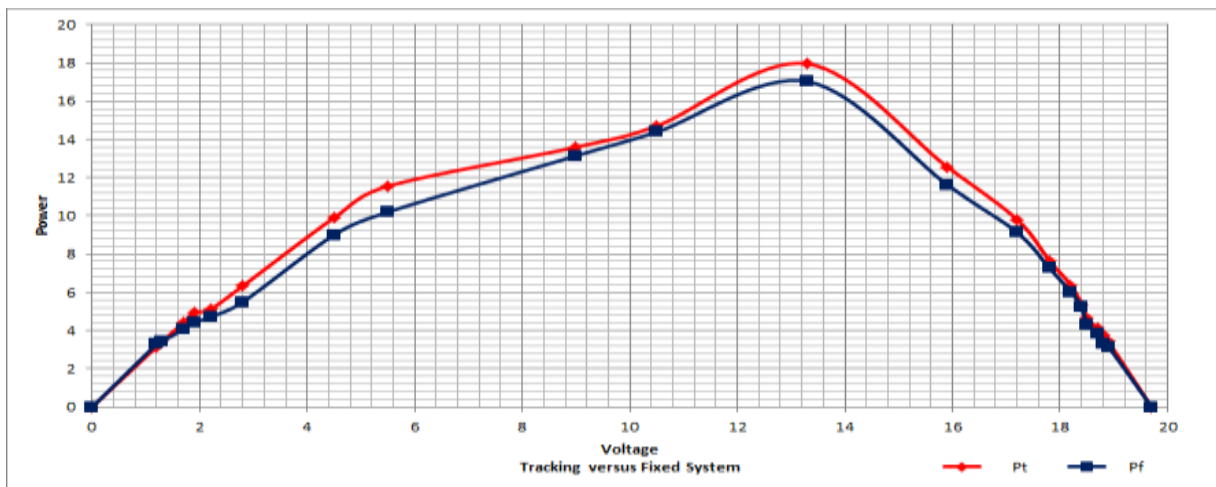

Fig 18 P-V curve for Tracking versus fixed system measured on 14/6/2016

4.2.2- Power versus time on 14-6-2016:

This measurements are taken from 8:00 AM to 5:00 PM for both systems. Table 4 lists the power measured versus time for both systems.

Figure 19 and Fig. 20 indicate the individual power curves versus time for fixed and tracking system respectively and Fig. 21 represents a comparison for fixed versus tracking system power with respect to time.

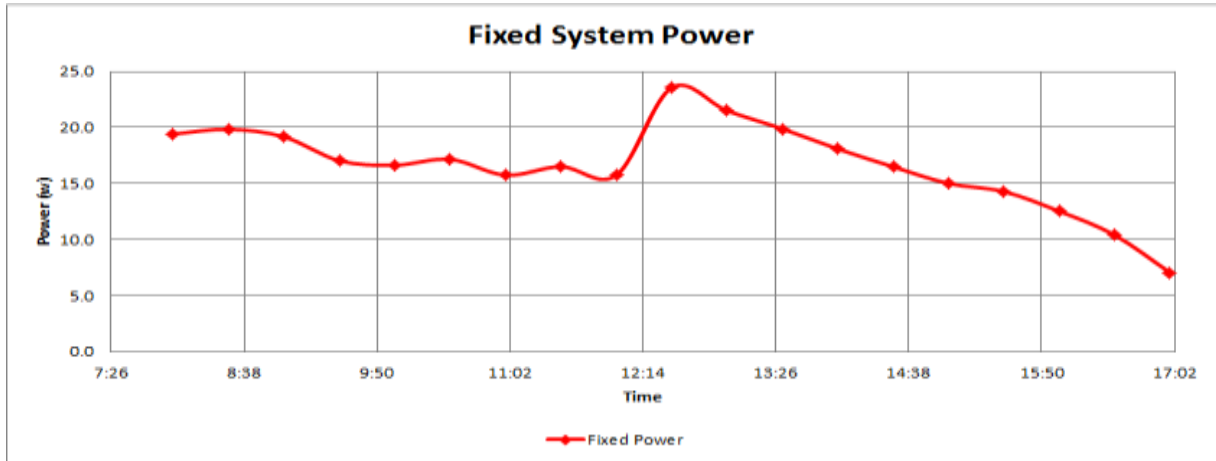

Fig 19 Power-Time curve for fixed system measured on 14/6/2016

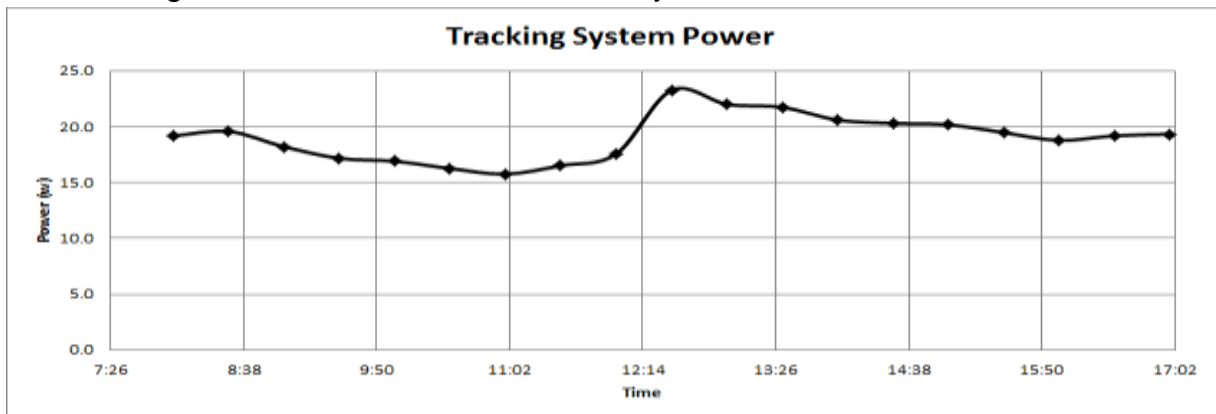

Fig 20 Power-Time curve for tracking system measured on 14/6/2016

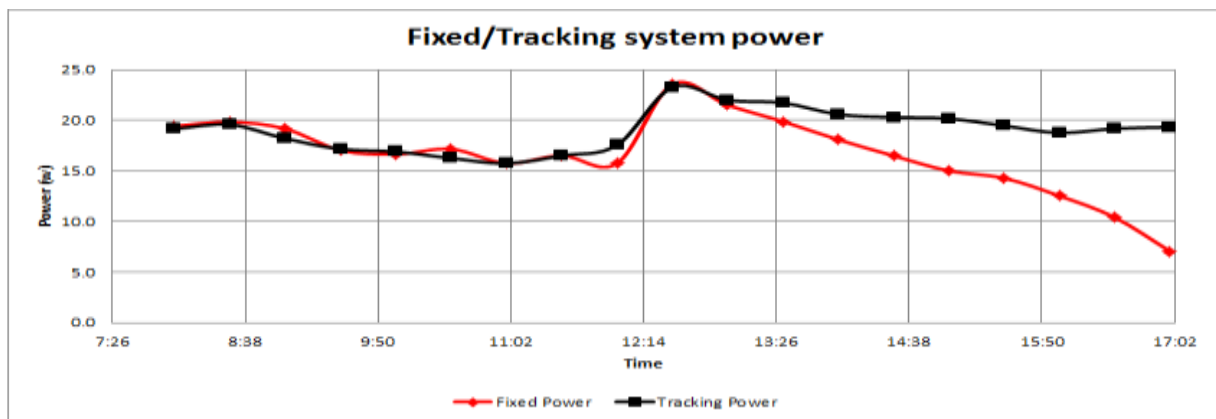

Fig 21 Power-Time curve for fixed and Tracking system measured on 14/6/2016

Journal of Engineering Science and Innovative Technology (IJESIT), Volume 2, Issue 2, March 2013.

[2] Sanzidur Rahman, Rashid Ahammed Ferdaus, Mohammad Abdul Mannan, Mahir American Academic & Scholarly Research Journal Vol. 5, No. 1, Jan. 2013.

IEEE Transactions on Industrial Electronics, Vol. 59, No. 1, Jan. 2012.

IEEE Transactions on Industrial Electronics, Vol. 59, No. 1, Jan. 2012.

IEEE Transactions on Industrial Electronics, Vol. 59, No. 1, Jan. 2012.



Author profile:

O.A. Monem, lecturer in communication and electronic department, Obour High Institute of engineering and technology Cairo, Egypt, He received BSC degree in Electric power and machines from Helwan University, Egypt in 1991, and Master degree of science in power electronics from Cairo University, Egypt in 2004, and PhD in power electronics from Cairo University, Egypt in 2013. His research field of interests are in the area of power quality, Harmonic mitigation,

Active filters, power factor correction, power rectifiers and multi-pulse converters.

Figures and Tables

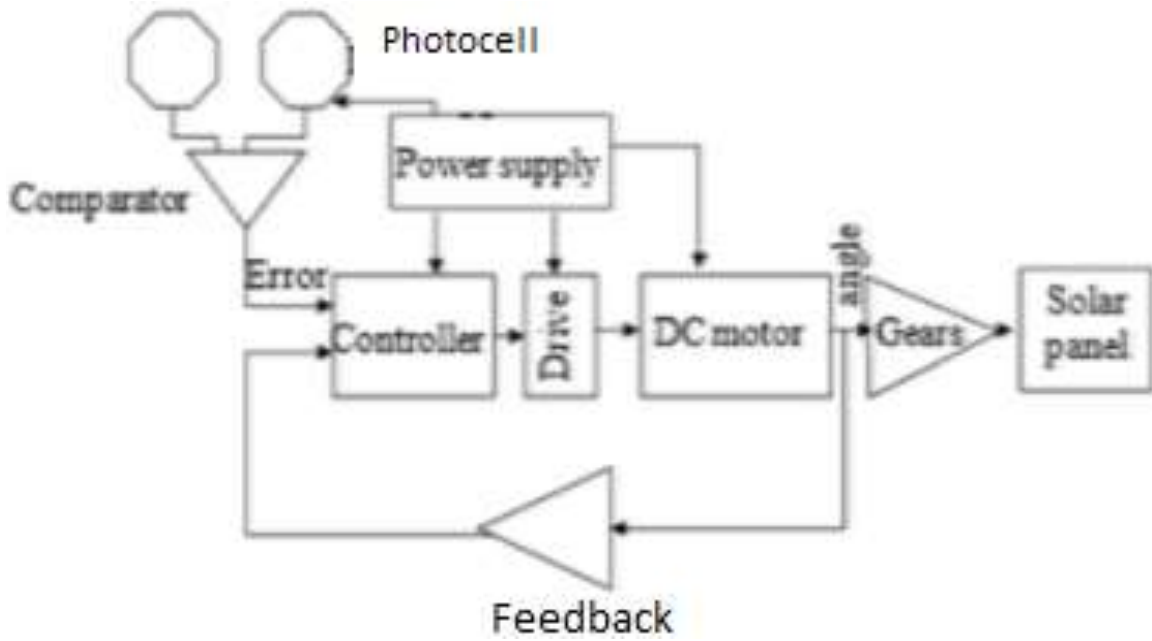

Fig. 1 Control circuit block diagram

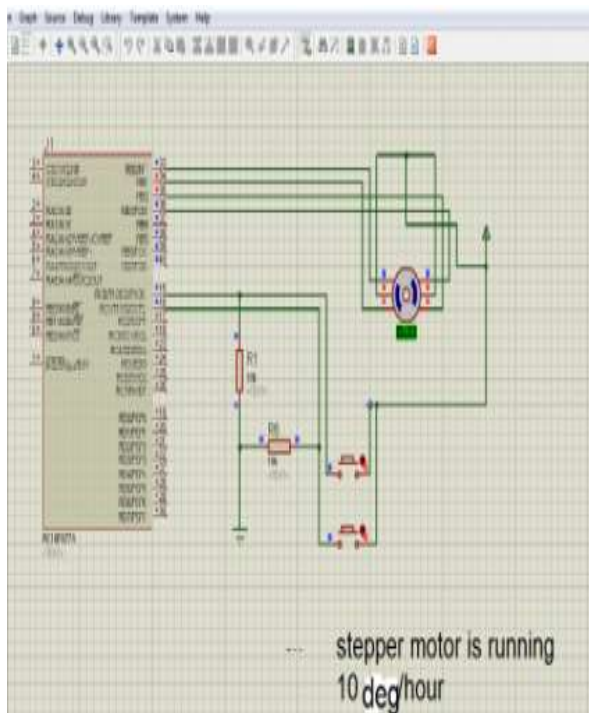

Fig. 2 Simulated stepper motor model.

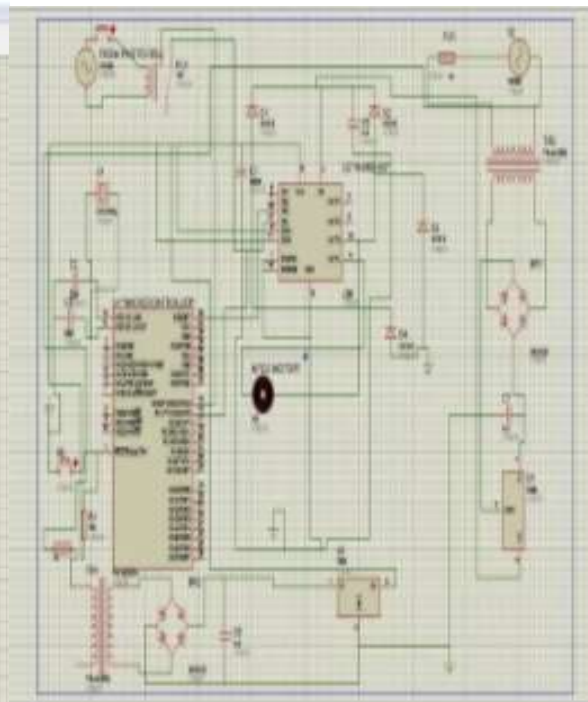

Fig. 3 Simulated DC motor model

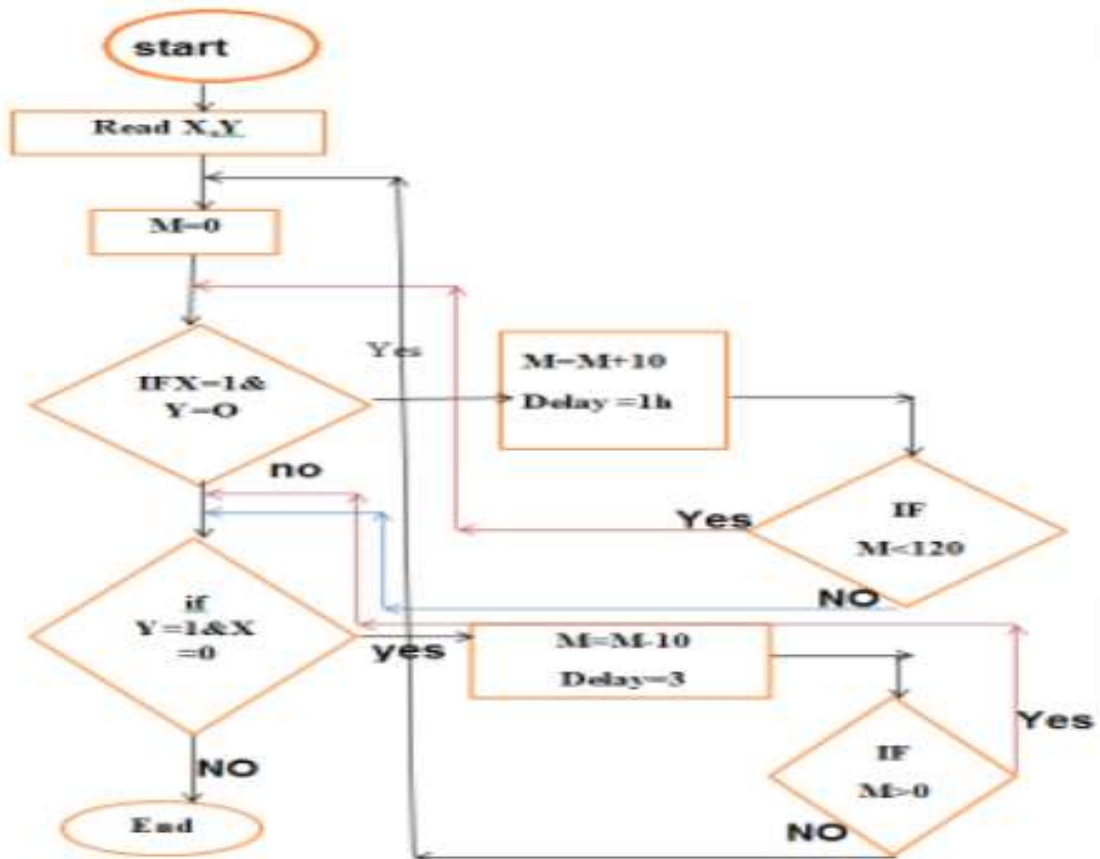

Fig. 4 Stepper Motor model flow chart



Fig.5 Simulated Solar panel angle controlled by microcontroller

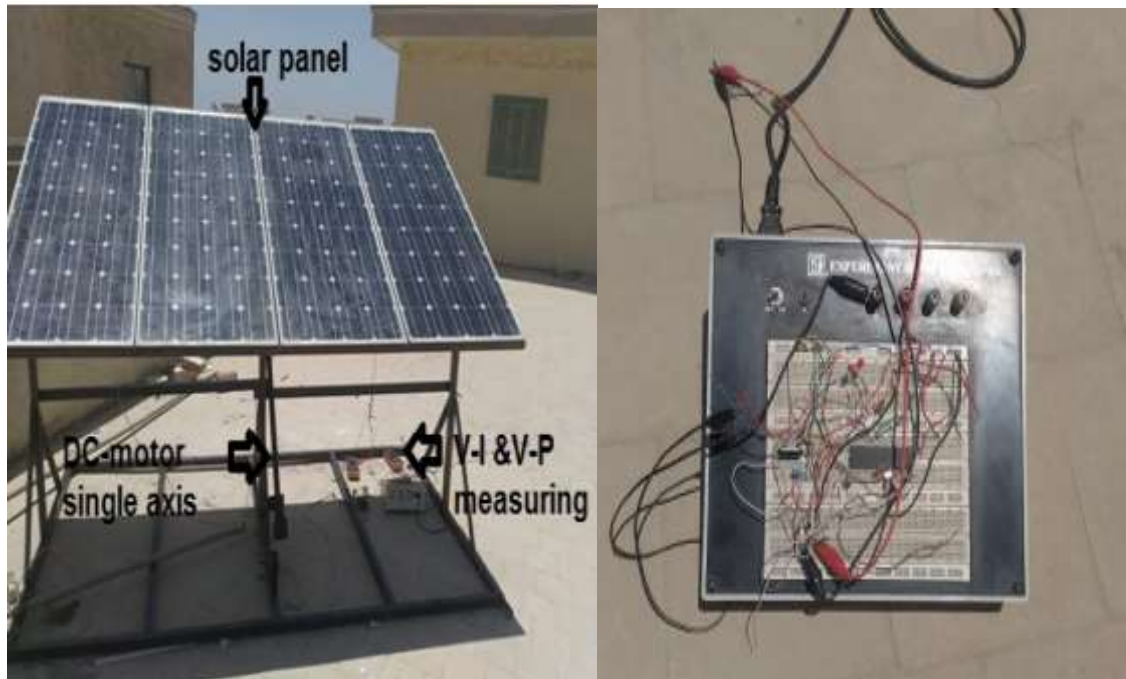

Fig. 22 Solar System and control circuit real photo



Fig. 23 System Tracking positions, initial, middle and final

Table 1 R-V-I-P measurement on 12th June

12 JUNE			
FOR FIXED PANEL			
R	V	I	Pf=V*I
SC	0	5.08	0
2	5.2	2.7	14.04
5	9.5	1.97	18.715
10	13	1.31	17.03
20	15.3	0.76	11.628
30	16.6	0.55	9.13
40	17.3	0.42	7.266
50	17.7	0.34	6.018
60	18	0.29	5.22
70	18	0.24	4.32
80	18.3	0.21	3.843
90	18.4	0.18	3.312
100	18.5	0.17	3.145
OC	19.5	0	0

Table 2 Power -Time reading for fixed and tracking system on 12th June

12- June Readings		
Time	Fixed Power	Tracking Power
8:30	27.5	27.2
9:30	25.3	24.2
10:30	24.5	23.9
11:00	23.6	24.5
11:30	22.8	23.1
12:30	23.6	22.6
13:30	19.9	20.3
14:00	18.1	20.6
15:00	15.0	20.2
15:30	14.3	19.5
16:00	12.5	18.8
16:30	10.4	19.2
17:00	7.1	19.3
Total	244.4	283.2
Average	18.8	21.8
Increase	16.60%	

Table 3 R-V-I-P Measurements on 14-June

14 JUNE			
Fixed at 12:00 PM			
R	V	I	Pf=V*I
SC	0	5.88	0
0.47	1.2	2.74	3.288
0.52	1.3	2.64	3.432
0.58	1.6	2.54	4.064
0.78	1.8	2.46	4.428
1	2.1	2.24	4.704
1.179	2.6	2.11	5.486
1.74	4.5	2	9
2	5.1	2	10.2
2.97	9	1.46	13.14
5	10.5	1.37	14.385
10	13	1.31	17.03
20	15.3	0.76	11.628
30	16.6	0.55	9.13
40	17.3	0.42	7.266
50	17.7	0.34	6.018
60	18	0.29	5.22
70	18	0.24	4.32
80	18.3	0.21	3.843
90	18.4	0.18	3.312
100	18.5	0.17	3.145

OC	19.5	0	0
----	------	---	---

Table 4 Power-Time reading for fixed and tracking system on 14th June

Time	Fixed Power	Tracking Power
8:00	19.4	19.2
8:30	19.8	19.6
9:00	19.2	18.2
9:30	17.0	17.2
10:00	16.6	16.9
10:30	17.2	16.3
11:00	15.8	15.8
11:30	16.5	16.5
12:00	15.8	17.6
12:30	23.6	23.3
13:00	21.5	22.0
13:30	19.9	21.7
14:00	18.1	20.6
14:30	16.5	20.3

15:00	15.0	20.2
15:30	14.3	19.5
16:00	12.5	18.8
16:30	10.4	19.2
17:00	7.1	19.3
Total	316.1	361.8
Average	16.6	19.0
Increase	19%	