

## Systematic Approach For Sharp Separation Network

Ali, B. D. A.\* Aly, S.A. and Awad, M. E

<sup>a</sup>Department of refining and petrochemical engineering, faculty of petroleum and mining engineering, Suez university

\*Corresponding author e-mail: [Basma.AhAl@pme.suezuni.edu.eg](mailto:Basma.AhAl@pme.suezuni.edu.eg)

### Abstract

Distillation is one of the main separating methods which is used frequently in the industrial field. For separating a multi-component feed mixture using distillation process, the sequence of distillation columns is so important, but unfortunately it is really hard to find the best sequence due to the large number of possibilities. This work developed a multi-object approach for the synthesis of the sharp separation network which is used to separate a large number of components in a mixture that was difficult to separate because it was difficult to select the appropriate separation sequence from the extensive number of potential splits. The use of three expert rules to qualify the estimated mass load, the difference in boiling point, and the relative volatility forms the basis of the synthesis algorithm. There are two fuzzy analogical gates in use (symmetric and asymmetric). The normalized predicted mass load and the normalized relative volatility are the inputs for the symmetric gate (AND gate). The output of the AND gate and the normalization of the boiling point difference are the inputs for the asymmetric gate (INVOKE gate). For separation issues with many components, the size is huge and the amount of decision variables is enormous. This approach not only can be used to find the optimum separation sequence but also can be used with a huge number of components which was so difficult to find their best separation sequence. Also, it has been noticed that the developed approach gave a lower total annual cost compared with any other methods. So, the suggested method can be carried out manually and is easy to use for a large number of components. Several illustrative examples using existing fuzzy analogical gate are provided as examples of the suggested method's success.

### Article Info

Received 2 Jun. 2023

Revised 25 Jul. 2023

Accepted 6 Aug. 2023

### Keywords

"Distillation processes; separation sequence synthesis; large number of components; fuzzy analogical gate; sharp separation"

### Introduction

The synthesis of multi-component separation procedures is one of the most significant subjects in the field of process systems design. Methods for multi-component separation are widely utilized in the petroleum refining sector. The choice of the suitable method and the best sequence are the challenge in the processes of multi-component separation [1].

One of the most researched difficulties in the synthesis of the different petroleum units is the construction of the sharp separation sequence process. It can be characterized it as follows: Develop a process that uses a single multi-component feed combination under specified conditions (i.e., flow rate, composition, temperature, and pressure). which is able to separate the necessary products from the feed for a low yearly cost (comprising the total of the plant's investment cost and annual running cost)[2].

All these synthesis techniques can be fractured into just three main groups: (a) heuristic methods founded on expertise in engineering, (b) evolutionary strategies that find the best sequence by modifying the one that was initially chosen, and (c) algorithmic methods that use optimization techniques from the world of mathematical programming[3].

However, because there are so many degrees of freedom involved, synthesizing such separation procedures is rather difficult. Finding the globally optimum flowsheet is particularly challenging because nonconvexity causes several local optimization problems with many degrees of freedom. Even when using simply straightforward, sharp separators, the multi-component product problem, which is a more general separation synthesis problem, has yet to be properly solved [4].

A lot of research has been done to optimize the distillation sequence. Timo Seuranen and et al., [5] described a new method for synthesizing separation processes and selecting single separations and that method is adaptable since it allows the user to extract different forms of information from the same cases by varying the search parameters, weights, and similarity measures, depending on the requirements and point of view. After a few years Massimiliano Errico and et al., [6] offered a systematic strategy for synthesizing any distillation system with less than N-1 columns and created a four-step process for separating an N-component mixture starting with basic column designs. Hence, the subspace of practical thermally linked configurations matching to fundamental column configurations was constructed. Based on this

Yiqing Luo and et al., [7] proposed a systematic optimization technique for maximizing the annual economic benefit of an existing crude oil distillation system taking into account both product output value and energy usage, and that described using a shortcut model in Aspen Plus. And the optimization is a nonlinear programming issue that is handled using a particle swarm optimization stochastic technique and improved the performance of an integrated refinery.

Gautham Madenoor Ramapriya and et al., [8] studied if short-cut performance-evaluation methodologies and associated assumptions might be used to model distillation settings, and that obtained the minimum heat duty that founded from two methodologies: the short-cut approach (GMA) and the rigorous stage-by-stage approach (ASPEN Plus).

After that Alessandro Di Pretoro and et al., [9] presented a new design technique based on feasible pathways and raised or eliminated from the correct column section selected the number of trays with the help of composition profiles analysis, starting from a convergent design based on shortcut approaches. And that generated an optimized solution that is very close to the best in a short amount of time, without the requirement to solve the MINLP issue.

Then Fanyi Duanmu and et al., [10] presented a novel shortcut strategy that used a simple optimization procedure to solve the shortcut design problem for sophisticated structures without the requirement for iterative manual effort And that created a new shortcut method which can be used for both simple and complex distillation column structures, and that takes into account any constraints imposed by the various structures while simultaneously solving the shortcut design without the need for repetitive procedure.

In this paper, A method to synthesis the best separation sequence for large number of components in the same mixture has been presented. This approach used the fuzzy analogical gate to select the best choice from a huge number of the possible splits using the main three parameters (the estimated mass load, the difference in boiling point, and the relative volatility). This method can be used for any number of components to get the optimum sequence with minimum total annual cost. Also, when the results of this research were compared with previous articles which used other techniques to find the best separation sequence, it was found that this article can reduce the total annual cost for the separation process by large percentage more than the previous researches.

## Problem statement

Sharp separation is the processes where the separation feed that consist of multi-component is separated into pure products at a minimum annual cost and minimum energy consumption, but the separation process faces a big problem that the number of separation sequence possibilities (SN)

increase dramatically with the number of components to be separated (N) as showing from the following main equation:  $SN = [2(N-1)]! / [N! (N-1)!]$  so, the way to choose the best separation sequence from the other possible splits is the separation processes challenge.

The following assumptions are made in order to simplify the synthesis problem:

- 1) A simple split is performed by each distillation column (i.e., one feed and two products)
- 2) Each column runs at a high recovery rate.
- 3) Changes in pressure have no effect on the volatility order.
- 4) Compared to the capital and energy expenditures of the columns, the cost of modifying the temperature and pressure of streams as they flow between them is negligible.
- 5) There is no vapor recompression

## Synthesis methodology

The synthesis methodology has three main steps to calculate the optimum separation sequence:

Step1. Determine the three main multi-object functions (the estimated mass load, the difference in boiling point, and the relative volatility).

Step2. Normalized the three functions including maximum of boiling point temperature difference, minimum of estimated mass load, and maximum of relative volatility (up to 3 components) using the following equations:

$$\text{Normalized temperature difference} = \frac{\Delta T - \Delta T_{\min}}{\Delta T_{\max} - \Delta T_{\min}} \quad (\text{equ.1})$$

$$\text{Normalized estimated mass load} = \frac{EML_{\max} - EML}{EML_{\max} - EML_{\min}} \quad (\text{equ.2})$$

$$\text{Normalized relative volatility} = \frac{\alpha - \alpha_{\min}}{\alpha_{\max} - \alpha_{\min}} \quad (\text{equ.3})$$

Step3. Use the fuzzy analogical gate network as shown in (Figure 1) to calculate the separation weight of each possible sequence and then select the best sequence as the largest separation weight value

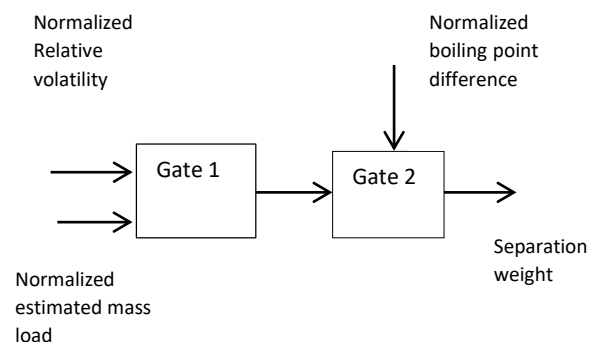

Figure 1 fuzzy analogical gate network

**Table1** estimated mass load for N number of components

Number of components (N)	EML Coefficients
1	0
2	$x_A + x_B = 1$
3	$3/2x_A + 2x_B + 3/2x_C$
4	$11/6x_A + 5/2x_B + 5/2x_C + 11/6x_D$
5	$25/12x_A + 17/6x_B + 3x_C + 17/6x_D + 25/12x_E$
N	$\sum_{i=1}^N a_{n,i}$ with $a_{1,1} = 0$ $a_{1,i} = \sum_{k=1}^{i-1} (1/K)$ if $i > 1$ $a_{i,j} = \sum_{k=1}^{i-j} (1/K + a_{i,j})$ if $k < i$

**Fuzzy analogical gate**

The fuzzy analogical gate is a novel way to describe logical statements with many values. It is a more thorough method that makes use of system variables and their associated values, which are more often used. This method extends the spectrum of conceivable applications of binary logic-based systems to real multi-valued logic-based systems. The creation and application of these gates for actual physical systems have also been shown to be efficient and simple. The method was built using two fuzzy analogical gates (symmetric and asymmetric).

**Symmetric Gate**

In the fuzzy analogical (AND) gate as shown in (Figure 2), When both inputs increase at once, the output rises faster, and if either input is 0, no output is generated. The parameters a and b may be determined using the parameters and zero derivatives on the major axis.

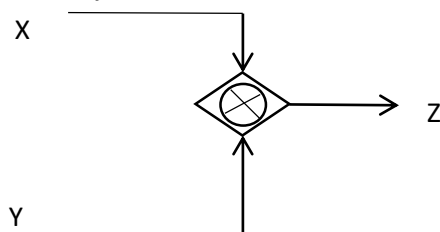

**Figure 2** Symbols for the analogical (AND) gate

$$Z = X[1 - \varepsilon(Y, X)] + Y[1 - \varepsilon(X, Y)] \quad (\text{equ.4})$$

$$\varepsilon(Y, X) = \exp\left[\frac{-ay^2 + byx}{y^2 + x^2}\right] \quad \text{and } x, y \in R \quad (\text{equ.5})$$

$$\varepsilon(X, Y) = \exp\left[\frac{-aX^2 + bxy}{y^2 + x^2}\right] \quad \text{and } x, y \in R \quad (\text{equ.6})$$

The parameters a and b may be determined using the parameters and zero derivative on the major axis. The constants a and b of the exponential function in this study are estimated to be 2.28466 and -0.89817, respectively.

**Asymmetric Gates**

The invoke gate is constructed so that when the x-input rises, more of the y-input is directed towards the output. When the x-input is not there, the output is stopped. In the absence of the y-input, the x-input is linearly transferred to the output, as shown in (Figure 3) At the prevail gate, the x-port is given an exceptional amount of control over the y-port. The latter gets put-through directly to the output if the former is absent. But nevertheless, when the input enters the dominant stage, the output is completely under its influence.

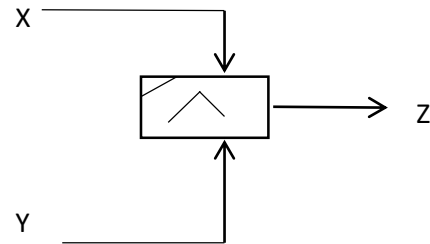

**Figure 3** Symbols for the analogical (invoke) gate

$$Z = X[1 - \varepsilon_1(Y, X)] + Y[1 - \varepsilon_2(X, Y)] \quad (\text{equ.7})$$

$$\varepsilon_1(Y, X) = \exp\left[\frac{-a_1y^2 + b_1yx}{y^2 + x^2}\right] \quad \text{and } x, y \in R \quad (\text{equ.8})$$

$$\varepsilon_2(X, Y) = \exp\left[\frac{-a_2X^2 + b_2xy}{y^2 + x^2}\right] \quad \text{and } x, y \in R \quad (\text{equ.9})$$

The parameters of exponential functions can be found using initial conditions and the zero derivative on the main axis. The constants' calculated values are as follows:  $a_1 = 1.4749267$ ,  $b_1 = 0.92870491$   
 $a_2 = 2.6317713$ ,  $b_2 = 0.2287955$

**Case study**

To demonstrate the effectiveness of the suggested approach, three case studies are solved. To evaluate the efficacy of our technique with other methods suggested in the literature, the first case study to differentiate a feed consists of a mixture of six light hydrocarbons, the second example to differentiate a mixture of five eight light hydrocarbons, and the third example to differentiate a mixture of ten light hydrocarbons.

**Case study 1:**

The first case study consists of six components that separated in six products by sharp separation. This case study was given by R.w Thompson and et al., [11] and S.aly in [1] It is desired to find the optimal sequence for the following feed, the feed stream is 800 kmol/hr with mole fraction as showed in Table (2).

Then the normalized boiling point difference, normalized estimated mass load and normalized relative volatility for (ABCDEF) have been calculated to estimate the separation weight for each possible split in

Table (3) So, ABC/DEF is the best choice because it has the largest separation weight value (0.887) where ABC will separate in the top and DEF will separate in the bottom.

**Table 2** Feed stream characteristics for case study 1

COMPONENT	MOLE FRACTION	BOILING POINT DIFFERENCE (°K)	RELATIVE VOLATILITY
A: ETHANE	0.20	40.9	5.21
B: PROPYLENE	0.15	5.70	1.27
C: PROPANE	0.20	35.8	4.31
D: I BUTENE	0.15	5.80	1.25
E: N-BUTANE	0.15	36.5	4.65
F: N PENTANE	0.15		

The possibilities split of components (ABC) and the normalization of the main three variables are used as input for fuzzy analogical gate to get the separation weight of each split as shown in Table (4) and A/BC is considered the best split because it has the largest separation weight value, A will separate in the top and BC will be separated in the bottom.

Same steps are repeated for separating (DEF) as shown in Table (5) the best split is DE/F, where DE will separate in the top and F in the bottom.

So, the total optimum separation sequence for separating (ABCDEF) as following:  
(ABC/DEF – A/BC – DE/F – B/C – D/E)

**Table 3** the normalization of the properties for (ABCDEF) possible splits in case study 1

split	Temperature difference (°k)	Normalized temperature difference	Estimated mass load	Normalized estimated mass load	Relative volatility	Normalized relative volatility	Separation weight
A/BCDEF	40.9	1.000	2.07	0.208	5.21	1.000	0.062
AB/CDEF	5.70	0.000	1.74	0.830	1.27	0.005	0.005
ABC/DEF	35.8	0.855	1.65	1.000	4.31	0.773	0.887
ABCD/EF	5.80	0.003	1.82	0.679	1.25	0.000	0.000
ABCDE/F	36.5	0.875	2.18	0.000	4.65	0.859	0.000

**Table 4** the possible splits to separate (ABC) in case study 1

split	Temperature difference (°k)	Normalized temperature difference	Estimated mass load	Normalized estimated mass load	Relative volatility	Normalized relative volatility	Separation weight
A/BC	40.9	1.000	0.636	1.000	6.92	1.000	1.000
AB/C	5.70	0.139	0.636	1.000	1.28	0.185	0.082

**Table 5** the normalization of the characteristics to each possible split to separate (DEF) in case study 1

split	Temperature difference (°k)	Normalized temperature difference	Estimated mass load	Normalized estimated mass load	Relative volatility	Normalized relative volatility	Separation weight
D/EF	5.80	0.159	0.666	1.000	1.24	0.336	0.235
DE/F	36.5	1.000	0.666	1.000	3.69	1.000	1.000

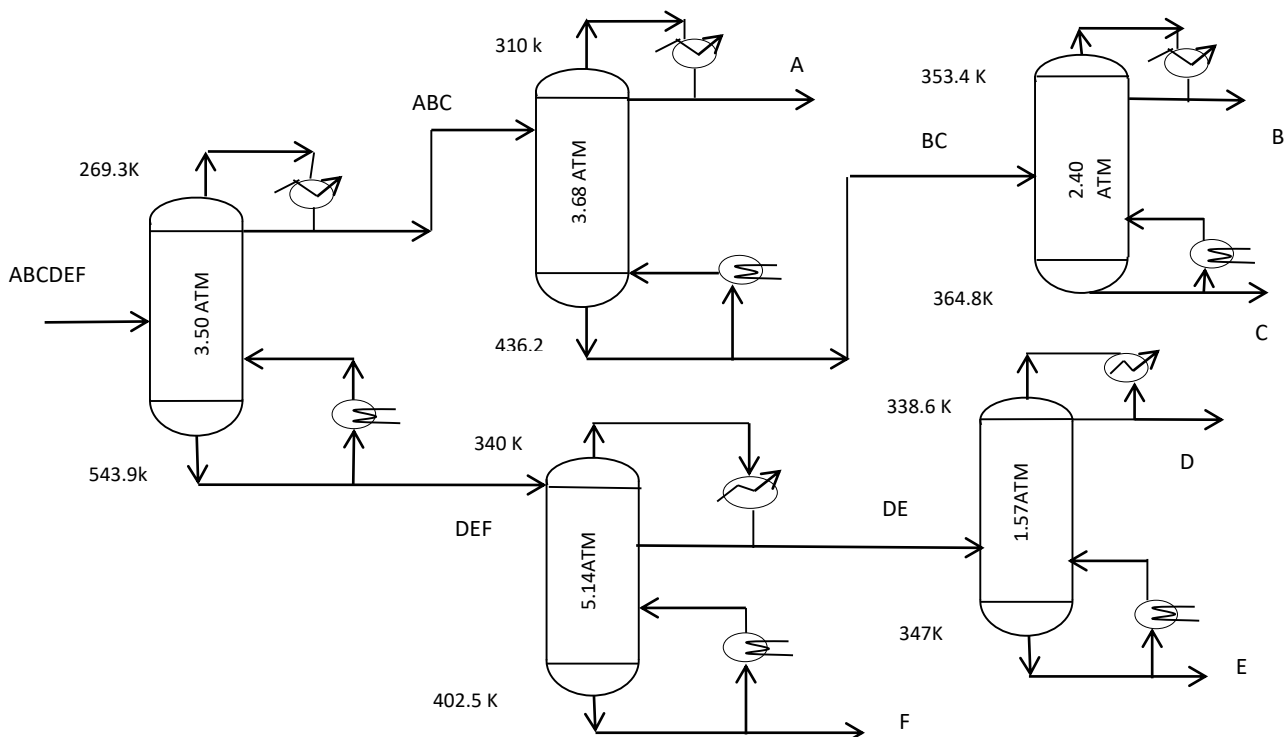
**Figure 4** Flow sheet of the separation sequence for case study 1

In the way to compare between this article's total annual cost and the other author's cost (for same case study) shown in Table (6) and Table (7) it has been proved that this article has the lowest total cost and that show the success of the recommended technique, a typical procedure of this method to calculate the total cost is given according to (Appendix A) in this paper

**Table 6** the cost of each split for case study 1

SPLIT	COST (\$/YR)
ABC/DEF	367742.2
A/BC	91481.23
AB/C	462925.6
DE/F	135876.2
D/E	434492.6
A/B	86071.80
B/C	368569.8

**Table 7** the total cost comparison for case study 1

Pervious work sequence	Total cost (\$/YR)	This work sequence	Total cost (\$/YR)
ABC/DEF- AB/C- DE/F- D/E- A/B	1,487,108	ABC/DEF- A/BC- DE/F- B/C- D/E	1,398,162

### Case study2:

The second case study consists of eight components that separated into eight products by sharp separation. This case study given by Bezzina and et al., [12], P.FLOQUET and et al., [2] and S.aly [1], The problem specifications are given in Table (8) with feed stream is 2000 kmol/hr. In the first step the main three variable parameters have been estimated then the normalized boiling point difference, normalized estimated mass load and normalized relative volatility for (ABCDEFGH) have been calculated to estimate the separation weight for each possible split in Table (9).

**Table 9** the possible splits for components (ABCDEFGH) for case study 2

Split	Temperature difference (°K)	Normalized temperature difference	Estimated mass load	Normalized estimated mass load	Relative volatility	Normalized relative volatility	Separation weight
A/BCDEFGH	73.0	1.000	3.080	0.000	8.350	1.000	0.000
AB/CDEFGH	40.8	0.522	2.740	0.347	4.038	0.391	0.411
ABC/DEFGH	5.70	0.000	2.431	0.663	1.272	0.000	0.000
ABCD/EFGH	30.3	0.366	2.155	0.939	3.457	0.309	0.246
ABCDE/FGH	11.3	0.083	2.099	1.000	1.607	0.048	0.002
ABCDEF/GH	36.5	0.458	2.210	0.887	4.912	0.514	0.542
ABCDEF/G/H	32.7	0.401	2.648	0.439	4.572	0.466	0.467

**Table 10** the normalization of the properties to each possible split for separating (ABCDEF) in case study 2

Split	Temperature difference (°K)	Normalized temperature difference	Estimated mass load	Normalized estimated mass load	Relative volatility	Normalized relative volatility	Separation weight
A/BCDEF	73.0	1.000	2.42	0.000	23.76	1.000	0.000
AB/CDEF	40.8	0.522	2.02	0.456	6.885	0.249	0.278
ABC/DEF	5.70	0.000	1.70	0.837	1.275	0.000	0.000
ABCD/EF	30.3	0.366	1.56	1.000	4.017	0.122	0.019
ABCDE/F	11.3	0.083	1.99	0.500	1.774	0.022	0.001

**Table 8** feed stream characteristics for case study 2

COMPONENT	MOLE FRACTION	BOILING POINT DIFFERENCE (°K)	RELATIVE VOLATILITY
A: METHANE	0.050	73.0	8.350
B: ETHANE	0.050	40.8	4.038
C: PROPYLENE	0.100	5.70	1.272
D: PROPANE	0.100	30.3	3.457
E: I-BUTANE	0.200	11.3	1.607
F: N-BUTANE	0.125	36.5	4.911
G: N-PENTANE	0.208	32.7	4.572
H: HEXANE	0.167		

ABCDEF/GH is the best choice because it has the largest separation weight value (0.542) where ABCDEF will separate in the top and GH will separate in the bottom

The possible split of components (ABCDEF) and the normalization of the main three variables are used as input for fuzzy analogical gate to get the separation weight of each split as shown in Table (10) and AB/CDEF is the best choice because it has the largest separation weight value (0.278) where AB will separate in the top and CDEF will separate in the bottom.

The Same steps are used to separate CDEF as shown in Table (11) and the best split is CD/EF because it has the largest separation weight value (1.000) where CD will separate in the top and EF will separate in the bottom.

So, the total optimum sequence is (ABCDEF/GH- AB/CDEF - CD/EF - A/B - G/H -C/D - E/F)

**Table 11** the possible splits to separate (CDEF) and their properties in case study 2

Split	Temperature difference (°K)	Normalized temperature difference	Estimated mass load	Normalized estimated mass load	Relative volatility	Normalized relative volatility	Separation weight
C/DEF	5.70	0.000	1.405	0.000	1.266	0.000	0.000
CD/EF	30.3	1.000	1.000	1.000	3.420	1.000	1.000
CDE/F	11.3	0.277	1.238	0.412	1.579	0.145	0.121

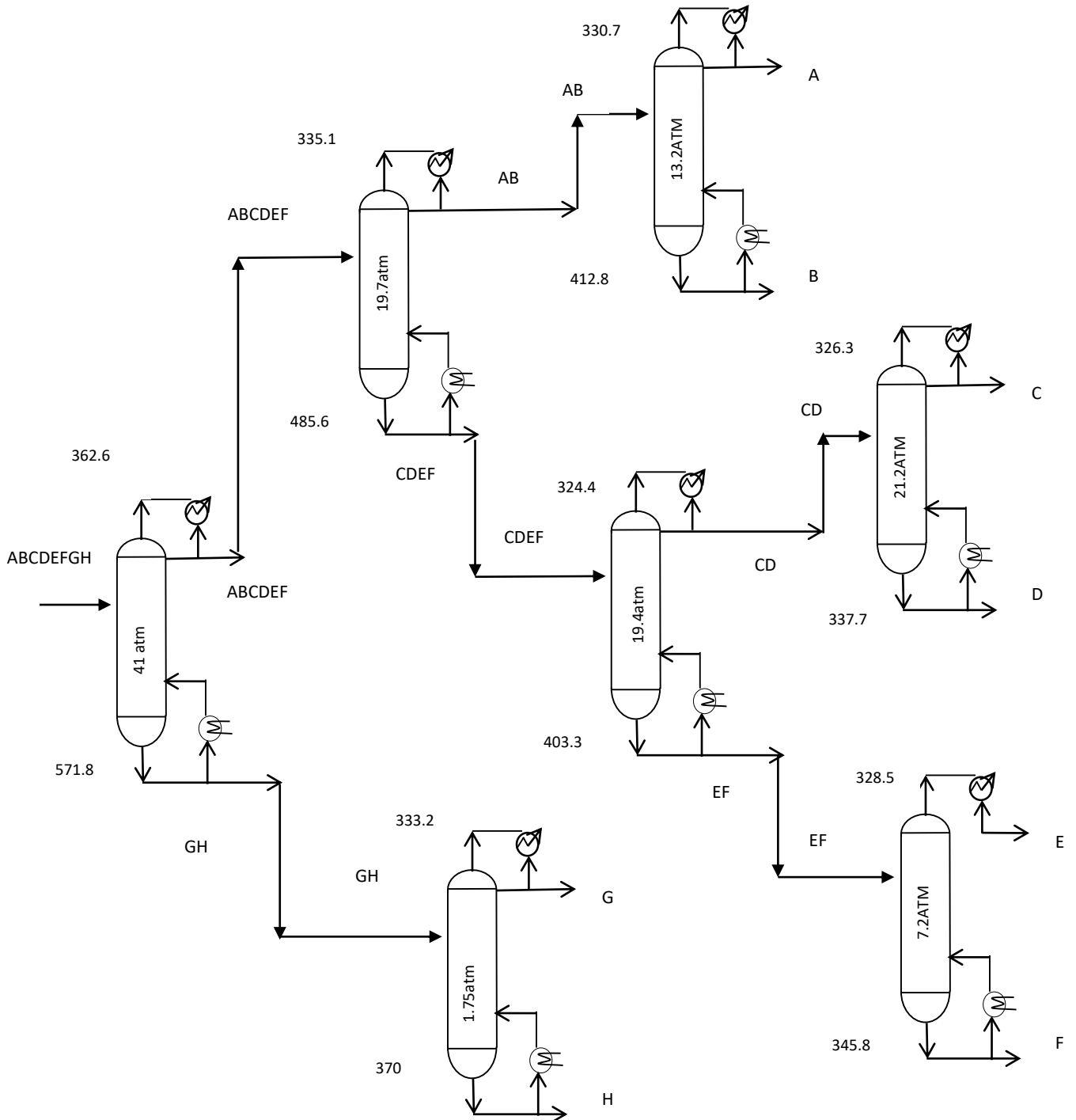
**Figure 5** Flow sheet of the separation sequence for case study 2

**Table 12** the cost of each split for case study 2

Split	Cost (\$/YR)
ABCD/EF GH	1498715
ABCDEF/GH	$1.97 \times 10^7$
AB/CDEF	1402848
AB/CD	$5.35 \times 10^7$
EF/GH	306645
CD/EF	244196
A/B	564687
C/D	456695
E/F	399559
G/H	254914

**Table 13** the total cost comparison for case study 2

Pervious work sequence	Total cost (\$/YR)	This work sequence	Total cost (\$/YR)
ABCD/EF GH – AB/CD – EF/GH – A/B – C/D – E/F – G/H	56,981,215	ABCDEF/GH – AB/CDEF – CD/EF – A/B – C/D – E/F – G/H	23,022,899

In the way to compare between this article's total annual cost and the other author's cost (for same case study) the cost of each column is shown in Table (12) and the total cost of this article and the comparison with the pervious results is shown in Table (13).

It has been proved that this article has the lowest total cost and that show the success of the recommended technique, a typical procedure of this method to calculate the total cost is given according to (Appendix A) in this paper

### Case study 3:

Consider the separation of the mixture of ten light hydrocarbons feed separated to pure component product. this case is studied by Rathore, Van Wormer [13] and An Wei-zhong and et al., [14] The problem specifications are given in Table (14) with feed stream is 1000 kmol/hr.

In the first step the main three variable parameters have been calculated then the normalized boiling point difference, normalized estimated mass load and normalized relative volatility for (ABCDEFGHJIJ) have been calculated to estimate the separation weight for each possible split in Table (15).

ABC/DEFGHJIJ is the best choice because it has the largest separation weight value (0.678) where ABC will separate in the top and DEFGHJIJ will separate in the bottom. The possible split of components (DEFGHJIJ) and the normalization of the main three variables are used as input for fuzzy analogical gate to get the separation weight of each split as shown in Table (16) and DE/FGHJIJ is the best choice because it has the largest separation weight value (0.371) where DE will separate in the top and FGHJIJ will separate in the bottom.

The Same steps are used to separate FGHJIJ as shown in Table (17) and the best split is FG/HIJ is the best choice because it has the largest separation weight value (1.00) where FG will separate in the top and HIJ will separate in the bottom. The same sequence of steps has been repeated to separate (HIJ) where the best split is H/IJ from Table (18) while the separating of (ABC) has a best sequence A/BC from Table (19) where it has the largest separation weight value.

So, the total optimum sequence is (ABC/DEFGHJIJ – DE/FGHJIJ – FG/HIJ – H/IJ – A/BC – B/C – I/J – F/G – D/E)

In the way to compare between this article's total annual cost and the other author's cost (for same case study) the cost for each column in the separation sequence of (ABCDEFGHJIJ) has been calculated in Table (20) then the total cost for this article's sequence and the total cost for the pervious articles have been compared as shown in Table (21).

It has been proved that this article has the lowest total cost and that show the success of the recommended technique, a typical procedure of this method to calculate the total cost is given according to (Appendix A) in this paper

**Table 14** feed stream characteristics for case study 3

Component	Mole fraction	Boiling point difference (°K)	Relative volatility $\gamma$
A:n-propane	0.05	41.6	2.98
B:n-butane	0.10	36.5	2.35
C:n-pentane	0.10	32.7	2.83
D:n-Hexane	0.05	29.7	2.35
E:n-Hebtane	0.15	27.2	2.11
F:n-Octane	0.20	25.2	2.07
G:n-Nonane	0.15	23.3	2.03
H:n-Decane	0.05	21.8	2.04
I:n-Undecane	0.10	20.4	1.99
J:n-Dodecane	0.05		

**Table 15** the normalization of the properties to each possible split for all mixture in case study 3

Split	Temperature difference (°K)	Normalized temperature difference	Estimated mass load	Normalized estimated mass load	Relative volatility	Normalized relative volatility	Separation weight
A/BCDEFGHIJ	41.6	1.000	3.589	0.000	2.98	1.000	0.000
AB/CDEFGHIJ	36.5	0.759	3.184	0.379	2.35	0.364	0.419
ABC/DEFGHIJ	32.7	0.580	2.937	0.610	2.83	0.848	0.678
ABCD/EFGHIJ	29.7	0.439	2.732	0.802	2.35	0.364	0.367
ABCDE/FGHIJ	27.2	0.321	2.521	1.000	2.11	0.121	0.020
ABCDEF/GHIJ	25.2	0.226	2.583	0.941	2.07	0.081	0.008
ABCDEFH/GIJ	23.3	0.137	2.904	0.641	2.03	0.040	0.003
ABCDEFH/IJ	21.8	0.066	3.190	0.374	2.04	0.050	0.010
ABCDEFH/IJ	20.4	0.000	3.588	0.000	1.99	0.000	0.000

**Table 16** the possible splits for separating (DEFGHIJ) in case study 3

Split	Temperature difference (°K)	Estimated mass load	Relative volatility	Normalized temperature difference	Normalized estimated mass load	Normalized relative volatility	Separation weight
D/EFGHIJ	29.7	3.34	2.45	1.000	0.000	1.000	0.000
DE/FGHIJ	27.2	2.11	2.01	0.731	0.848	0.371	0.371
DEF/GHIJ	25.2	1.89	1.93	0.516	1.000	0.257	0.159
DEFG/HIJ	23.3	2.12	1.75	0.312	0.841	0.000	0.000
DEFGH/IJ	21.8	2.41	1.80	0.150	0.641	0.071	0.011
DEFGHI/J	20.4	2.83	1.78	0.000	0.352	0.043	0.010

**Table 17** the separating of (FGHIJ) with the properties of each possible split in case study 3

Split	Temperature difference (°K)	Normalized temperature difference	Estimated mass load	Normalized estimated mass load	Relative volatility	Normalized relative volatility	Separation weight
F/GHIJ	25.2	1.00	1.349	0.88	1.17	0.00	0.00
FG/HIJ	23.3	0.60	1.273	1.00	2.83	1.00	1.00
FGH/IJ	21.8	0.29	1.499	0.72	1.67	0.30	0.28
FGHI/J	20.4	0.00	1.907	0.00	1.68	0.31	0.00

**Table 18** the normalization of the possible split for separating (HIJ) in case study 3

Split	Temperature difference (°K)	Normalized temperature difference	Estimated mass load	Normalized estimated mass load	Relative volatility	Normalized relative volatility	Separation weight
H/IJ	21.8	1.000	0.748	1.00	1.69	1.00	1.00
HI/J	20.4	0.936	0.748	1.00	1.59	0.94	0.92

**Table 19** the normalization of the properties to each possible split for separating (ABC) in case study 3

Split	Temperature difference (°K)	Normalized temperature difference	Estimated mass load	Normalized estimated mass load	Relative volatility	Normalized relative volatility	Separation weight
A/BC	41.6	1.000	0.8	1.00	4.91	1.00	1.00
AB/C	36.5	0.877	0.6	0.75	3.98	0.81	0.84

**Table 20** the cost of each split for case study 3

Split	Cost (\$/Yr)
A/BCDEFGHIJ	114175
ABC/DEFGHIJ	262386
BC/DEFGHIJ	225458
DE/FGHIJ	362565
FG/HIJ	416948
F/GHIJ	$1.85 \times 10^7$
G/HIJ	501441
A/BC	57801
H/IJ	442395
F/G	404322
B/C	81557.0
I/J	1002976
D/E	108185



**Table 21** the total cost comparison for case study 3

Pervious work sequence	Total cost (\$/Yr)	This work sequence	Total cost (\$/Yr)
A/BCDEFGHIJ – BC/DEFGHIJ – B/C – DE/FGHIJ – D/E – F/GHIJ – G/HIJ – H/IJ – I/J	21,338,752	ABC/DEFGHIJ – DE/FGHIJ – FG/HIJ – H/IJ – A/BC – B/C – I/J – F/G – D/E	3,139,135

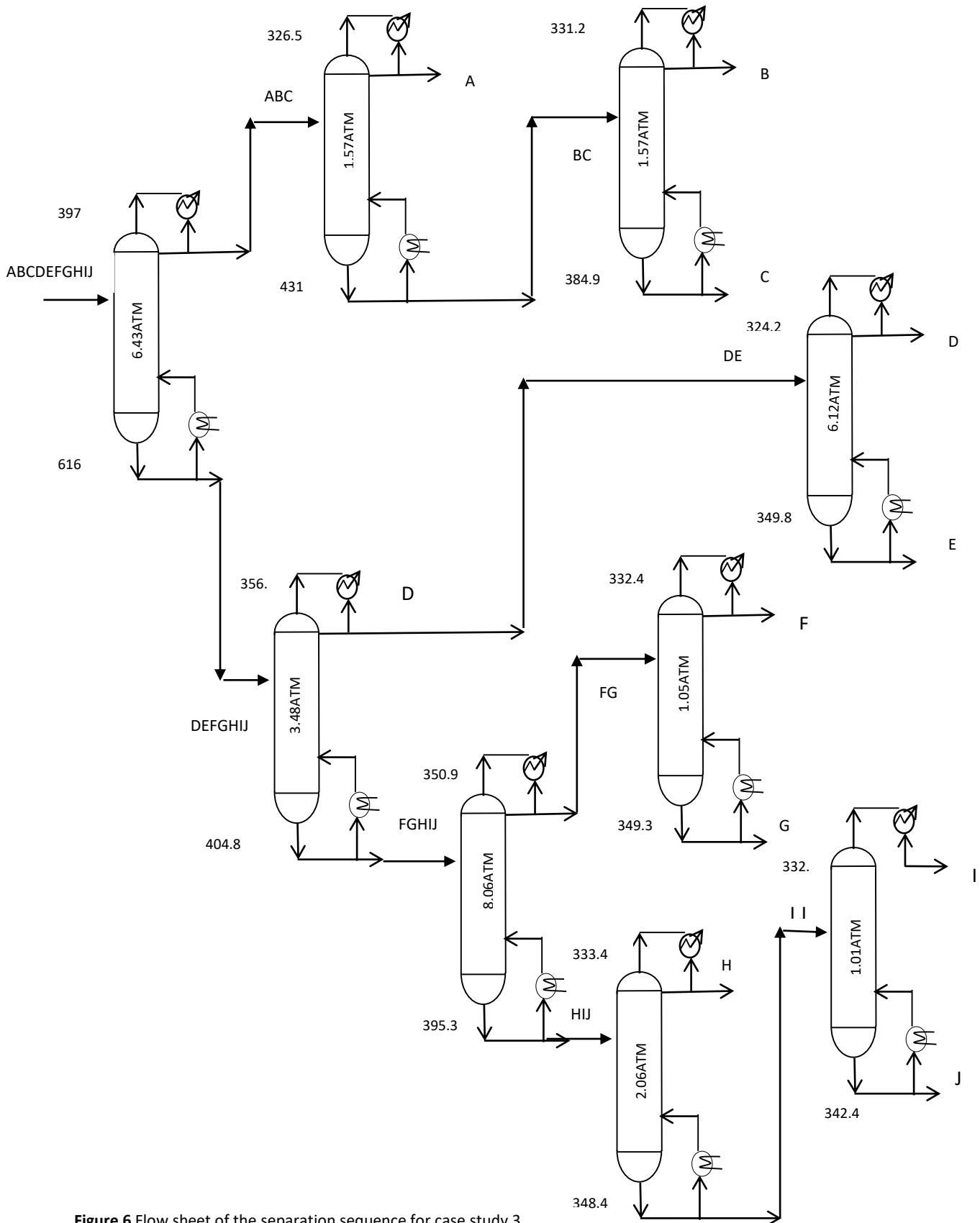
**Figure 6** Flow sheet of the separation sequence for case study 3

## Conclusions

Synthesizing optimum distillation systems has many benefits. The various degrees of freedom present, unfortunately, make it challenging to synthesize such separation processes. As a problem with several degrees of freedom typically has various local optima, finding the globally optimum flowsheet is extremely difficult.

The reduction in the total annual cost of any separation process is one of the most important economic aspects. Therefore, the aim of this article not only to find the best separation sequence but also to reduce the total annual cost of the separation process.

This paper provides a method which used fuzzy analogical gate to select the best separation sequence which considered the optimum sequence from all other possibilities. This method is noticed to be an easy method to obtain the optimum sequence for any number of components. Also, it can be used to select the best sequence for a large number of components.

The synthesis algorithm is based on the application of three expert criteria to justify the estimated mass load, the change in boiling point, and the relative volatility. To show the success of the recommended technique, three case studies containing six, eight, and ten components are solved.

The three main case studies that have been solved in this work show the effectiveness of this method in selecting the optimal sequence for the separation process. Which has lower annual cost in compared with the previous articles that talked about the same topic. Also, it is clear that the Fuzzy Analogical Gate performance is highly encouraging, and the technique is very easy to use, it is also may be programmed by hand.

## Funding sources

"This research received no external funding"

## Conflicts of interest

"There are no conflicts to declare".

## Appendix A

The shortcut approach is still beneficial for detecting problems for computer simulations and for any design tasks. The main reason to calculate the column cost and the total annual cost, it's also used to determine the lowest reflux ratio  $R_{min}$  and the lowest number of stages  $N_{min}$ .

The component material balance is established as following:

$$f_i = b_i + d_i \quad \text{and} \quad b_{LK} = f_{LK} - d_{LK}$$

$$b_{HK} = f_{HK} - d_{HK}$$

Recalculate the top and bottom overall flow rate composition using Hengstebach and Geddes' algorithm.

$$b_i = f_i / [1 + \text{Exp}(c_1 + c_2 \ln \alpha_i)]$$

$$\text{Where } c_1 = \ln\left(\frac{d_{LK}}{b_{LK}}\right) \quad \text{and} \quad c_2 = \frac{\ln\left[\left(\frac{d_{LK}}{b_{LK}}\right)\left(\frac{p_{LHK}}{b_{HK}}\right)\right]}{\ln\left(\frac{\alpha_{LK}}{\alpha_{HK}}\right)}$$

$$X_{Di} = \frac{d_i}{\sum d_i} \quad \text{and} \quad X_{Bi} = \frac{b_i}{\sum b_i}$$

Then the calculation of column pressure by using Marquess correlation

$$p = p_0 \sum_{i=LK}^c X_{i,D} \text{EXP} \left[ \left( \frac{\Delta H_i}{R} \right) \left( \frac{1}{T_{i,o}} - \frac{1}{T_{m,D}} \right) \right]$$

This step main to calculate the distillate and bottom temperatures ( $T_D$ ,  $T_B$ ) by using this equation

$$T_D = \left[ -\left( \frac{R}{\Delta H} \right) \ln\left(\frac{\sigma_f}{\sigma_D}\right) + \frac{1}{T_f} \right]^{-1}$$

$$T_B = \left[ -\left( \frac{R}{\Delta H} \right) \ln\left(\frac{\sigma_b}{\sigma_f}\right) + \frac{1}{T_f} \right]^{-1}$$

Calculate  $N_{min}$ , the minimal number of steps, using the Fenske equation.

$$N_{min} = \frac{\ln\left(\frac{X_{LK,D}}{X_{LK,B}}\right)\left(\frac{X_{HK,B}}{X_{HK,D}}\right)}{\ln(\alpha_{LK}/\alpha_{HK})}$$

Apply Underwood's equation to the distillation column to obtain the minimal reflux ratio, ( $R_m$ ).

$$1 - q = \sum_{i=1}^n (\alpha_i X_{fi}) / (\alpha_i - \theta)$$

$$R_m + 1 = \sum_{i=1}^n (\alpha_i X_{Di}) / (\alpha_i - \theta)$$

In 1940, Gilliland developed the correlations. The minimal reflux ratio ( $R_{min}$ ) and the minimum number of stages ( $N_{min}$ ) can be used to correlate the column stages under the constraint of limited reflux ratio.

$$\frac{N - N_{min}}{N + 1} = 0.75 \times \left[ 1 - \left( \frac{R - R_{min}}{R + 1} \right)^{0.5688} \right]$$

Gilliland equation is used to calculate the number of stages at operating reflux ratio, its required knowledge the minimum reflux ratio only to plotted X-Y graphical

$$y = \frac{(N - N_{min})}{(N + 1)} \quad X = \frac{(R - R_{min})}{(R + 1)}$$

Eduljee made equation to find an approximate relation, which best describes the original Gilliland plot

$$y = 0.75 - 0.75X^{0.5668}$$

By using the Kirkbride equation to estimate the feed plate location

$$\frac{N_u}{N_L} = \left[ \left( \frac{X_{HK}}{X_{LK}} \right) \left( \frac{X_{LK,B}}{X_{HK,B}} \right)^2 \left( \frac{B}{D} \right) \right]^{0.206}$$

**Table 22** the definitions of the abbreviations

Abbreviations	Definitions
B	Number of moles in bottom
F	Number of moles in feed
D	Number of moles in distillate
LK	Light key
HK	Heavy key
$p_o$	The stander pressure (1 ATM)
C	The number of components
$\Delta H_i$	The heat of vaporization of the C number of components
$T_{i,o}$	The boiling point of component at pressure $p_o$
$T_{m,D}$	The bubble point temperature
$X_{HK}$	The composition of heavy component
$X_{LK}$	The composition of light component
$\alpha_i$	The relative volatility of component i
$X_{fi}$	Molar fraction of component i in the feed
$X_{Di}$	Molar fraction of component i in the top
$\theta$	The relative volatility (which range between $\alpha_{LK}$ and $\alpha_{HK}$ )
N	Total number of theoretical contact plates
R	Reflux ratio
$N_{min}$	Minimum number of plates
$R_{min}$	Minimum reflux ratio
$N_u$	The theoretical number of stages above the feed
$N_L$	The theoretical number of stages below the feed
D	The top product flow rate
B	The bottom product flow rate

## References

[1] S. Aly, "HEURISTIC APPROACH FOR THE SYNTHESIS OF HEAT-INTEGRATED DISTILLATION SEQUENCES," *Chemical Engineering and Processing* 36 (1997) 209-217

[2] P. Floquet, ' L Pibouleau', S. Aly, and S. Domenech', "FUZZY HEURISTIC APPROACH FOR SHARP SEPARATION SEQUENCE SYNTHESIS," 1994. *Computers and chemical engineering* Vol. 18, No. 9, pp. 785-795, 1994

[3] M. Murakiand and T. Hayakawa, "SEPARATION PROCESS SYNTHESIS FOR MULTICOMPONENT PRODUCTS." *Journal of chemical engineering of Japan* vol.17 no.5 1984

[4] Z. Hu and B. Chen, "HEURISTIC SYNTHESIS FOR MULTICOMPONENT PRODUCTS WITH SIMPLE AND SHARP SEPARATORS," *computers and chemical engineering* Vol. 17. No. 4, pp. 379-397, 1993

[5] T. Seuranen, M. Hurme, and E. Pajula, "Synthesis of separation processes by case-based reasoning," in *Computers and Chemical Engineering* 29, Elsevier Ltd, May 2005, pp. 1473–1482. doi: 10.1016/j.compchemeng.2005.02.016.

[6] M. Errico, G. Tola, B. G. Rong, D. Demurtas, and I. Turunen, "Energy saving and capital cost evaluation in distillation column sequences with a divided wall column," *Chemical Engineering Research*

*and Design*, vol. 87, no. 12, pp. 1649–1657, Dec. 2009, doi: 10.1016/j.cherd.2009.05.006.

[7] Y. Luo, L. Wang, H. Wang, and X. Yuan, "Simultaneous optimization of heat-integrated crude oil distillation systems," *Chin J Chem Eng*, vol. 23, no. 9, pp. 1518–1522, Sep. 2015, doi: 10.1016/j.cjche.2015.03.008.

[8] G. M. Ramapriya, A. Selvarajah, L. E. Jimenez Cucaita, J. Huff, M. Tawarmalani, and R. Agrawal, "Short-Cut Methods versus Rigorous Methods for Performance-Evaluation of Distillation Configurations," *Ind Eng Chem Res*, vol. 57, no. 22, pp. 7726–7731, Jun. 2018

[9] Alessandro Di Pretoro and etc. A feasible path-based approach for Dividing Wall Column design procedure *Computers & Chemical Engineering Volume 149*, June 2021

[10] Fanyi Duanmu and etc. A shortcut design method for complex distillation structures *Chemical Engineering Research and Design Volume 180*, April 2022, Pages 346-36

[11] R. W. Thompson and C. J. King, "Systematic Synthesis of Separation Schemes CONCLUSIONS A N D SIGN I FICANCE," 1972. *AIChE Journal* (Vol. 18, No. 5) pp. 941

[12] M. Bezzina, L. Pibouleau~, and S. Domenech Ecole, "A STATISTICAL APPROACH TO THE SYNTHESIS OF SEPARATION SEQUENCES," 1989. *Computers & chemical engineering* Vol. 13, No. 6, pp. 651-660,

[13] RAM N. S. RATHORE and etc. "Synthesis Strategies for multicomponent Separation Systems with Energy Integration" 1974. *AIChE Journal Wok* 20, (No. 3) pp.491

[14] A. Wei-zhong and Y. Xi-Gang, "A simulated annealing-based approach to the optimal synthesis of heat-integrated distillation sequences," *Comput Chem Eng*, vol. 33, no. 1, pp. 199–212, Jan. 2009, doi: 10.1016/j.compchemeng.2008.08.001.

[15] Z. Xiong, K. Guo, H. Cai, H. Liu, W. Xiang, and C. Liu, "Distillation process optimization: A screening-clustering assisted kriging optimization method," *Chem Eng Sci*, vol. 238, Jul. 2021

[16] J. P. M. Cardoso and K. Tannous, "Development of a computational tool for designing multicomponent distillation columns," *Computer Applications in Engineering Education*, vol. 28, no. 4, pp. 908–922, Jul. 2020

[17] A. G. Kamel, M. Kaoud, and S. M. Aly, "Multiple Criteria Method for Designing Distillation Sequence for Sharp Separation," *International Journal of Engineering Research and Technology*, vol. 13, no. 9, pp. 2305–2312, 2020

[18] J. Ryu and C. T. Maravelias, "Efficient generalized shortcut distillation model with improved accuracy for superstructure-based process synthesis," *AIChE Journal*, vol. 66, no. 11, Nov. 2020

[19] R. Tumbalam Gooty, R. Agrawal, and M. Tawarmalani, "An MINLP formulation for the optimization of multicomponent distillation configurations," *Comput Chem Eng*, vol. 125, pp. 13–30, Jun. 2019

[20] H. Hou and Y. Luo, "A novel method for generating distillation configurations," *Front Chem Sci Eng*, vol. 14, no. 5, pp. 834–846, Oct. 2020

[21] A. Tsirlin, I. Sukin, and A. Balunov, "Selection of optimum separation sequence for multicomponent distillation," *ChemEngineering*, vol. 3, no. 3, pp. 1–11, Sep. 2019

[22] F. Wang, Y. Luo, and X. Yuan, "A formulation methodology for multicomponent distillation sequences based on stochastic optimization," *Chin J Chem Eng*, vol. 24, no. 9, pp. 1229–1235, Sep. 2016