

## **Power-Sharing in Microgrids by Adaptive Virtual Impedance and Fuzzy Logic**

Samia Abdalfatah<sup>a</sup>, E. E. El-kholy<sup>b</sup>, and Hilmy Awad<sup>a\*</sup>

<sup>a</sup>*Department of Electrical Technology, Helwan University, Cairo, Egypt*

<sup>b</sup>*Professor, Dean Institute of Aviation Engineering and Technology, Egyptian Aviation Academy, Ministry of Civil Aviation.*

\*Corresponding author: Hilmy Awad, Faculty of Technology and Education, Helwan University, Egypt, Email: [hilmy\\_awad@techedu.helwan.edu.eg](mailto:hilmy_awad@techedu.helwan.edu.eg)

### **Abstract**

Microgrid is a new paradigm for current and future energy distribution systems that enable renewable energy integration. The microgrid generally consists of multiple distributed generators interfacing with the grid through power inverters. When the islanded microgrids are concerned, it is essential to maintain the system stability and achieve load power sharing among the multiple parallel-connected distributed generation units. However, poor active and reactive power-sharing is expected due to the influence of impedance mismatch of the distributed generation feeders. The key objective of this work is to estimate the virtual impedance value to nullify the power-sharing errors without the need for communication links. A fuzzy logic controller is proposed to estimate the value for virtual impedance based on the instantaneous real and reactive power demands. The virtual impedance dynamically changes depending on the load demand to compensate for the feeder impedance mismatch, hence called adaptive virtual impedance. The proposed power-sharing control strategies are validated using Matlab/Simulink simulation under four operational scenarios. The proposed fuzzy controller provides precise reactive power sharing and helps to eliminate the need for communication links. In addition, it provides superior dynamic performance.

**Keywords:** Fuzzy Logic Control; Microgrid; Power Sharing; Parallel Inverters; Virtual Impedance

## Introduction

Fossil fuels (coal, oil, natural gas, etc.) have a limited life span and limited reserves. They are the main reason behind pollution, reflected in environmental health risks and economic threats. Therefore, spreading alternate energy sources will reduce these effects and the global energy crisis.

Among the renewable energy sources, PV and wind energy are the most harnessed and integrated with the electrical grid [2, 3], forming microgrids. The DC/AC inverter is a critical component of any power-electronic-based microgrid consisting of high-switching frequency, solid-state devices, and a low pass filter. An L filter or LCL filter is usually placed between the inverter and the grid to attenuate the switching frequency harmonics produced by the grid-connected inverter [20]. Compared with the L filter, the LCL filter has a better attenuation capacity of high-order harmonics and better dynamic characteristics [2, 3]. However, an LCL filter can cause stability problems due to the undesired resonance caused by zero/low impedance at specific frequencies. Several damping techniques have been proposed to prevent this resonance from contaminating the system. One way is to incorporate a passive physical element, such as a resistor in series with the filter capacitor [4]. This passive damping solution is straightforward and highly reliable. However, the additional resistor results in power loss and weakens the attenuation ability of the LCL filter. This drawback can be overcome by employing power-sharing based on virtual impedance. The goals of power-sharing are 1) adequate power-sharing and 2) accurate power control without communication, if possible. Power-sharing is achieved in several ways, including master-slave controllers, current chain schemes, and droop control [21]. The first and second methods depend on power-sharing on a connection between the controls of the inverters. This increases the cost and reduces reliability. By the droop control method, the power is shared between the inverters without communication links. The droop control features include precise reactive power management and minimal frequency and voltage deviations [16]. Many studies have also increased DG power-sharing accuracy by enhancing droop control [7, 9], which can be mitigated using virtual impedance. The virtual impedance technique can vary the reactance and/or resistance of the output impedance of inverters with no more physical inductors and/or resistors, which minimizes the system's size and cost [9].

The research gap is stated as follows. The virtual impedance dynamically changes depending on the load demand to compensate for the feeder impedance mismatch. Thus, preset control parameters fail to track the load demands. Hence, we propose identifying the instantaneous load demands using fuzzy logic in this paper.

A fuzzy logic controller is proposed to estimate the values of the virtual impedance based on the real power demand at that particular instant. The virtual impedance dynamically changes depending on the load demand to compensate for the feeder impedance mismatch, hence called adaptive virtual impedance. Thus, the proposed fuzzy logic controller makes accurate reactive power sharing possible without requiring communication links and the knowledge of feeder impedance.

## **II. Proposed System**

A typical microgrid configuration is shown in Figure 1. The system consists of two solar energy subsystems and a DC-DC converter to obtain the maximum power. The LCL and LC filters use an inverter and harmonic reduction to convert from DC to AC. The robust construction of each inverter to operate in parallel with the other inverters in the system is a major problem for parallel-running inverters. The virtual impedance concept shares electrical power among inverters equally (reasonably). This paper presents a controller design and implementation, including maximum power point tracking for PV and equal power sharing by all system inverters. The proposed controller is validated by MATLAB / SIMULINK environment under constant and variable weather conditions and fixed and variable loads. The robust construction of each inverter to operate in parallel with the other inverters in the system is a major problem for parallel-running inverters. The virtual impedance concept shares electrical power among inverters equally (reasonably). This paper presents a controller design and implementation, including maximum power point tracking for PV and equal power sharing by all system inverters. The proposed controller is validated by MATLAB / SIMULINK environment under constant and variable weather and loading conditions.

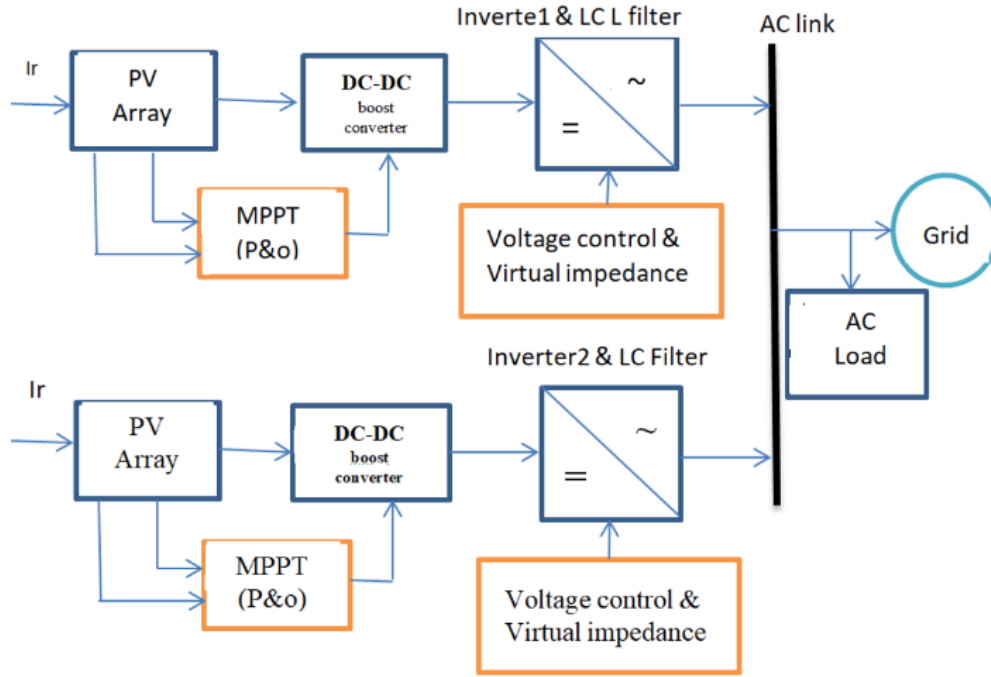

Figure 1. General micro grid Structure

**A. Photovoltaic System Model**

A PV module consists of several PV cells connected in series and parallel to obtain the desired voltage and current output levels, as shown in Figure 2. A common PV model consists of a photocurrent source  $I_{ph}$ , diode, series resistances  $R_s$ , and shunt resistance  $R_p$  [35, 36].

$I$ : Solar cell current (A).

$I_{ph}$ : Light produced current (A).

$I_D$ : Diode saturation current (A).

$I_o$ : reverse saturation current of the diode

$T$ : array temperature (in K).

$q$ : electron charge ( $1.6 \times 10^{-19}C$ )

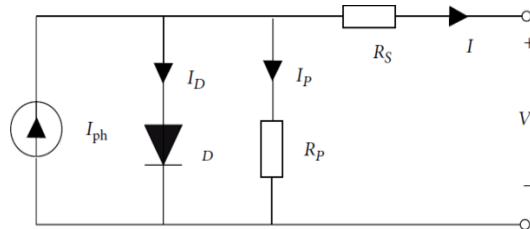

Figure 2 Model of PV cell

$$I = I_{ph} - I_o [\exp (q(V + I R_s)/KT)) - 1] - (V + I R_s) / R_p \quad (1)$$

Where

$$I_D = I_o [\exp(q(V + IR_s)/KT) - 1] \tag{2}$$

**B. Maximum Power point Tracking**

Power provided by a PV panel significantly depends on existing atmospheric conditions (irradiation and temperature). Consequently, the operational point requests to be tracked continuously by an MPPT technique to produce the maximum obtainable power [29]. The power output of a circuit is maximum when the circuit impedance (source impedance) matches the load Impedance. Hence our problem of tracking the maximum power point reduces to an impedance matching problem. There are different techniques used to track the maximum PowerPoint. MPPT technique is constructed on the hill-climbing Perturb and Observe method [32]. The main advantage of this approach is the simplicity of the technique. Furthermore, previous knowledge of the PV panel characteristics is not required. This method performs well in its simplest form, provided solar irradiation does not vary too quickly [9, 24].

The adapted MPPT technique is the Perturb and Observe, which controls the boost converter, as shown in Figure 3. The output signal from the MPPT controller is compared with the PV voltage, and the error signal is sent to the PI controller to eliminate zero. The output signal from the PI controller is the duty cycle sent to the boost converter switch [10,18]. Figure 4 shows the Schematic diagram of the boost converter control.

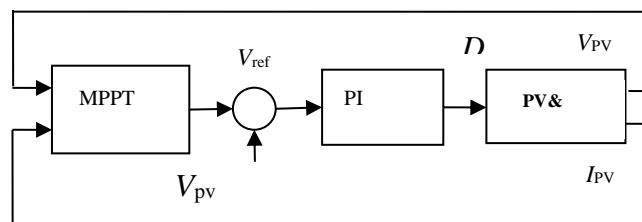

Figure. 3. Schematic diagram of boost converter control.

**C. DC/AC Inverter and LCL Filter**

The DC/AC inverter is a critical component of any power electronic-based microgrid [34], consisting of high switching frequency solid-state devices and a low pass filter. As shown in Figure 4, the input of the inverter is DC, produced across the DC link capacitor

[30,31], while the output is AC generated on the output of the inverter. The switching devices, IGBTs, receive control signals from a voltage controller. The latter produces pulse width modulation (PWM) signals correlated to the reference voltage signal. The AC output of the switching devices contains many harmonic signals resulting from switching. Consequently, an LCL filter attenuates these harmonics and produces a sine wave power signal. However, an LCL filter can cause stability problems due to the undesired resonance caused by zero impedance at specific frequencies [5].

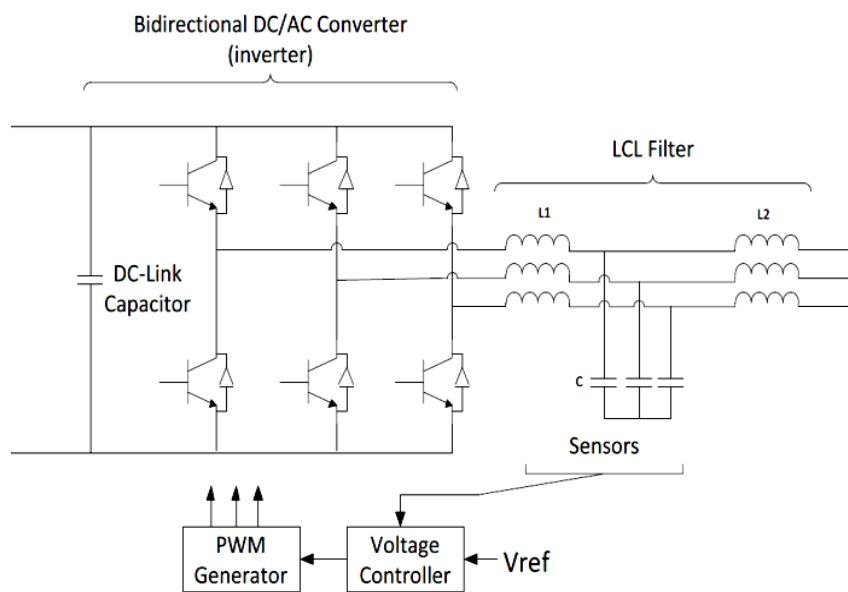

Figure 4 Inverter and LCL filter

### III. Adaptive Virtual Impedance Technique

A voltage control loop is used in basic voltage source inverters VSI to track the desired input signal and reduce its error and the measured output voltage. A proportional controller,  $K_v$ , is utilized in this study, backed by a feed-forward loop. The feed-forward loop reduces steady-state error while allowing for a broader control band [1] [3].

Figure 4 depicts an inverter configuration with an LCL filter. The inner loop controllers are shown in this block diagram [12-14]. This paper uses a virtual impedance concept to unify the nature of the output impedance for inverters working parallel. This impedance mimics the behavior of an inductor or resistor in the program. Using a programmable impedance rather than a physical one reduces the losses and costs [19-22]. In addition,

being programmable presents adaptive operation and increases the inverter's robustness against network impedance variations [23-27]. Figure 5 shows the block diagram of the voltage controller with the virtual impedance  $Z_v(s)$ .

$$V_o(s) = G(s) * V^*(s) - Z_{ov}(s) * I_o(s) \tag{3}$$

The output impedance with virtual impedance can be derived as,

$$Z_{ov}(s) = Z_o(s) + G(s) Z_v(s) \tag{4}$$

The nature of  $Z_v$  could be chosen to be resistive as,

$$Z_v(s) = R_v \tag{5}$$

Where  $R_v$  is the resistance of the virtual impedance, or it can be inductive as

$$z_v(s) = \frac{s}{\tau_v s + 1} L_v \tag{6}$$

Where  $L_v$  is the inductance of the virtual impedance and  $\tau_v$  is the time constant of the high pass filter used to approximate the derivative in the transfer function of the ideal virtual inductance  $Z_v = sL_v$  [25].

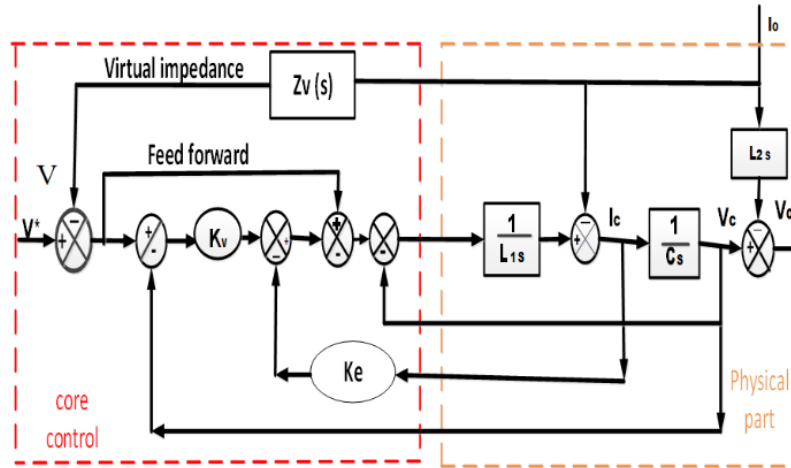

Figure 5. Model of basic double-loop voltage controller

Calculating of  $z_v$  value is done through the following equation.

$$z_v(s) = \frac{v_o^*(s).G(s) - Z_o(s).I_o(s) - v_o(s)}{G(s).I_o(s)} \tag{7}$$

Figure 6 shows the model of virtual impedance  $Z_v(s)$ . Calculating  $G(s)$  and  $Z_o(s)$  values are done through the following equations.

$$G(s) = \frac{K_v + 1}{L_1 Cs^2 + K_e Cs + K_v + 1} \tag{8}$$

In the case of using the induction current of the filter

$$Z_{ol} = \frac{L_1 s + K_e}{L_1 Cs^2 + K_e Cs + K_v + 1} + L_2 s \tag{9}$$

In the case of using the capacitive impedance current of the filter

$$Z_{ol} = \frac{L_1 s}{L_1 C s^2 + K_e C s + K_v + 1} + L_2 s \tag{10}$$

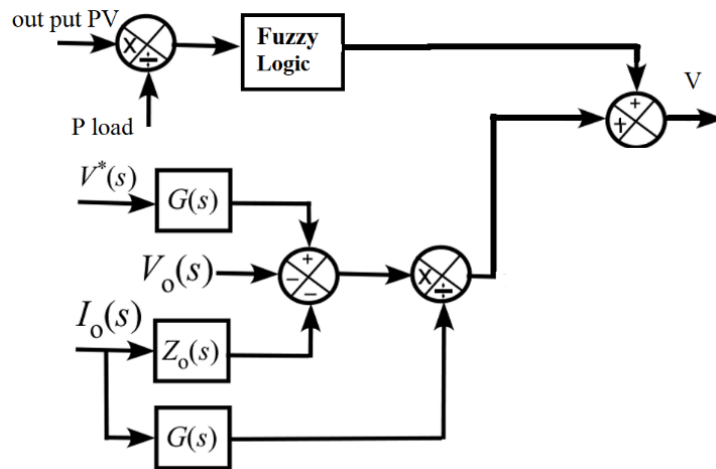

Figure. 6 Model of virtual impedance  $Z_v(s)$ .

The estimation of virtual impedance based on the fuzzy logic controller with the unknown feeder impedance and fluctuating loads has been proposed. This fuzzy controller eliminates the need for communication between parallel-operated DGs. In the proposed scheme, each parallel DG includes a fuzzy controller that estimates the value of the virtual impedance required for the respective line. A fuzzy controller, like a dangling controller, uses locally available signals as input, i.e., a quotient by  $\frac{P_{mean}}{P_{load}}$ , thus eliminating communication links using the measured values for this input, the controller estimates the ambiguity, which is then measured to get a percentage that is added to the default resistance to get an accurate value of the default resistance

#### IV. Simulation Results and Discussions

Figure 7 shows the performance of the PV module and the performance of perturb and observe algorithm to track the maximum power point of the PV module under various weather conditions. The PV module simulation is implemented in MATLAB Simulink. The system is simulated during five different cases between constant and changing solar radiation and constant and changing loads



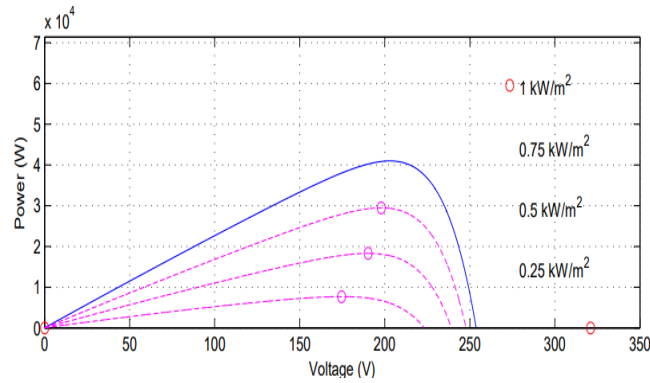

Figure7 Characteristics of PV

**Case 1:**

Figure 8 shows sun irradiance  $1000 \text{ w/m}^2$ . In this case, the solar radiation is constant within 6 seconds. To make it easier to view the performance of the virtual impedance, a switch has been set to reverse between using and not using the virtual impedance.

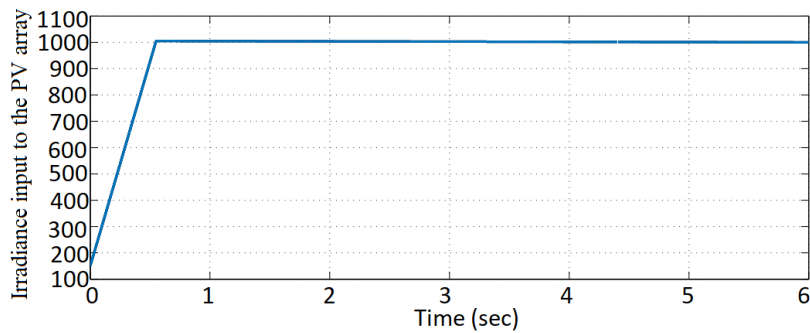

Figure .8 Irradiance input to the PV array

Figure 9 shows the active power output curves of the two PV modules with a solar radiation value of  $1000 \text{ W/m}^2$  and a constant temperature of 25 degrees. In 1.9 seconds, there was an instantaneous change in the energy value due to switching between the above two states.

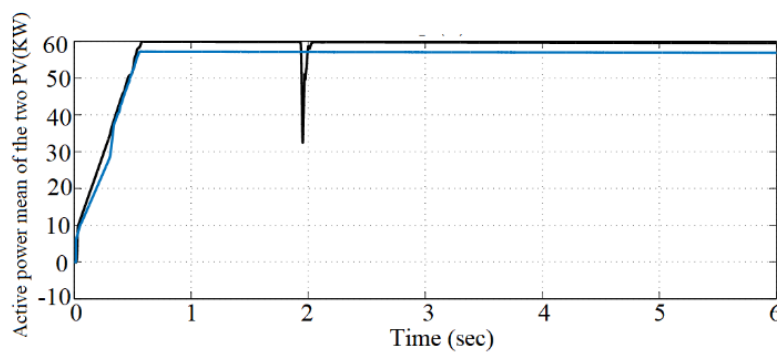

Figure 9 Active power mean of the two inverters

Figure 10 shows the output power of each inverter. It is assumed that both inverters are already operating in parallel and that without virtual impedance turned on at the beginning of the operation, we notice that the output of the inverter that uses a filter of the LCL type, the value of the power is less than half of the required value until it reaches a time of 1.9 seconds. The switch position is switched to the virtual impedance mode, so both inverters give maximum power. Here a fixed value of the virtual impedance was used

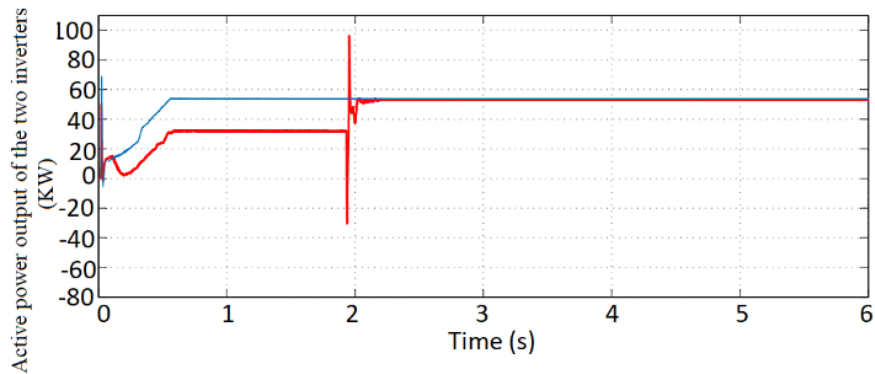

Figure 10 Active power output of the two inverters

**Case 2:**

A constant value of the virtual impedance was also used here. Figure 11 shows the sun's radiation is variable

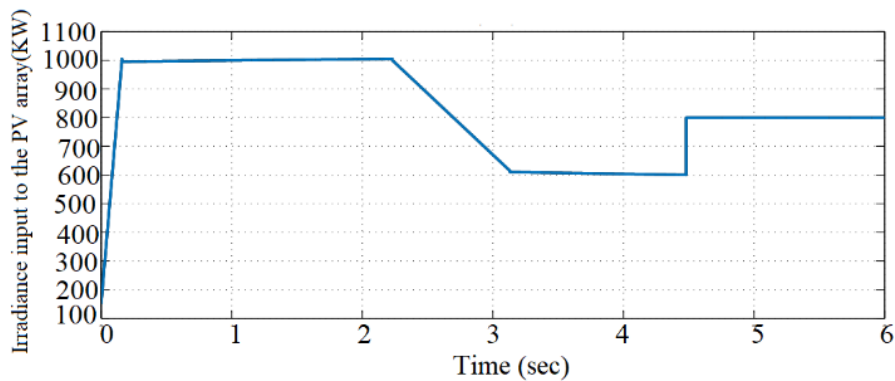

Figure 11 Irradiance input to the PV array

Figure 12 shows the output power of each inverter. It is assumed that both inverters are already working in parallel. With the use of a fixed virtual impedance, we will notice that both inverters give their maximum power until the olfactory radiation changes and the power decreases, and at a time of 3 seconds, the output of the inverter used, the LCL filter, the value of the power decreased by a small percentage.

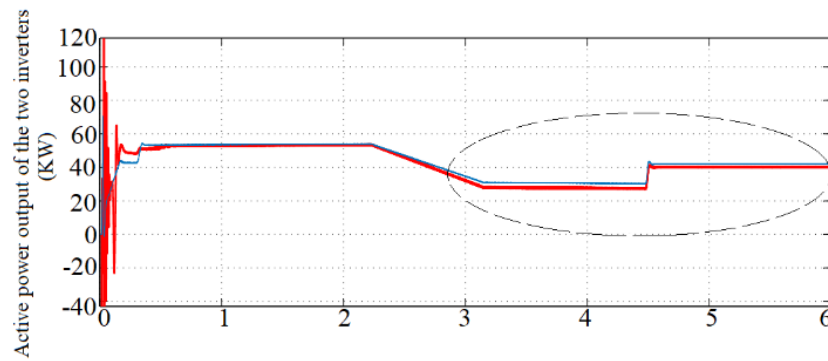

Figure 12 Active power output of the two inverters

### Case 3

Figure 13 shows the sun's radiation of 1000 watts / m<sup>2</sup>; in this case, the solar radiation is constant within 6 seconds. In this case, a variable virtual impedance was used, dimming according to equation (7), and the loads were changed with the constant solar radiation.

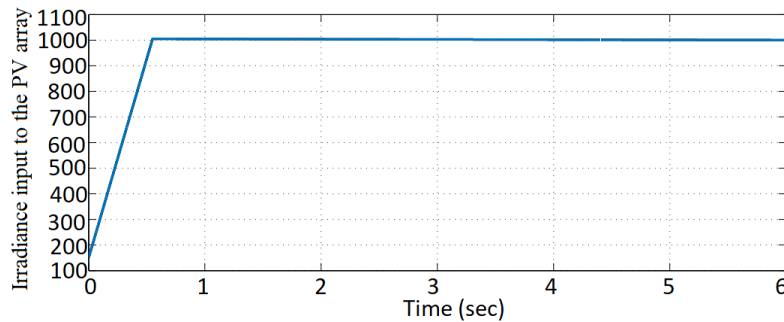

Figure 13 Irradiance input to the PV array

Figure 14 shows the output power of each inverter. It is assumed that both inverters are already operating in parallel. Using a virtual variable impedance, we will notice that both inverters give their maximum power even when the loads change.

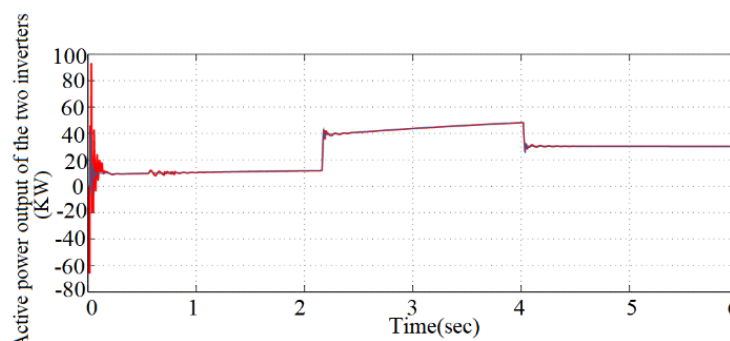

Figure 14 Active power output of the two inverters

### Case 4

A variable value was used for the virtual impedance. Its value depends on Equation No. 8. Figure 15 shows the sun's radiation as a variable with the change of loads

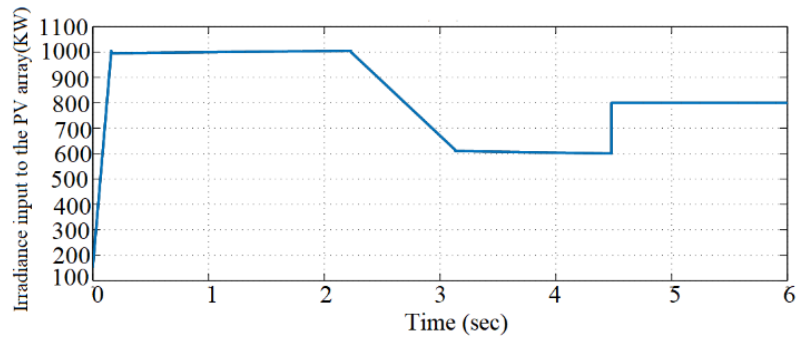

Figure 15 Irradiance input to the PV array

Figure 16 shows the output power of each inverter. It is assumed that both inverters are already operating in parallel. Using a virtual variable impedance, we will notice that both inverters give their maximum power even when the loads and solar radiation change.

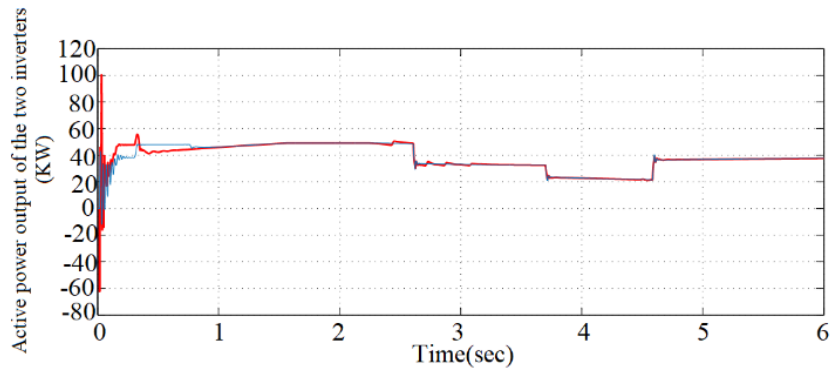

Figure 16 Active power output of the two inverters

**Case 5**

Figure 17 shows different solar radiation, where the first is 1000 W/m<sup>2</sup> and the second is 700 W/m<sup>2</sup>, in which case the solar radiation is constant within 6 seconds. In this case, a virtual variable impedance was used, dimming according to Equation no 8, and with constant solar radiation, the loads were fixed

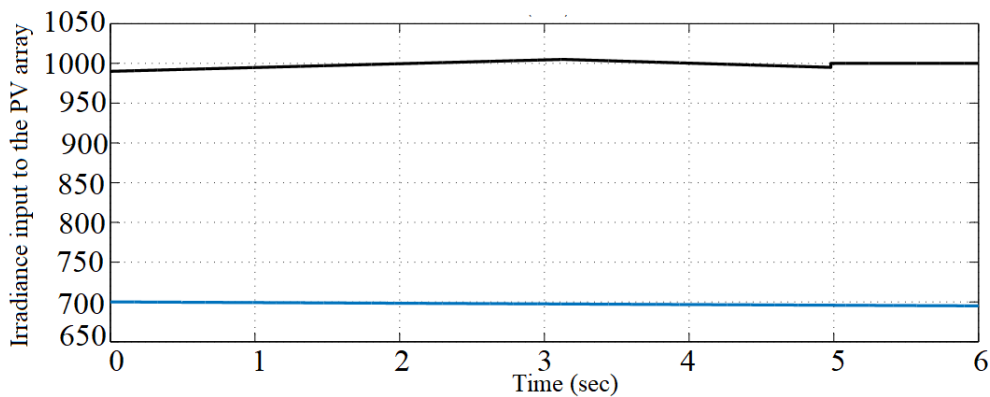

Figure 17 Irradiance input to the PV array.

Figure 18 shows the output power of each inverter. It is assumed that both inverters are already operating in parallel. Using a virtual variable impedance, we will notice that both inverters mid-range the required load capacity.

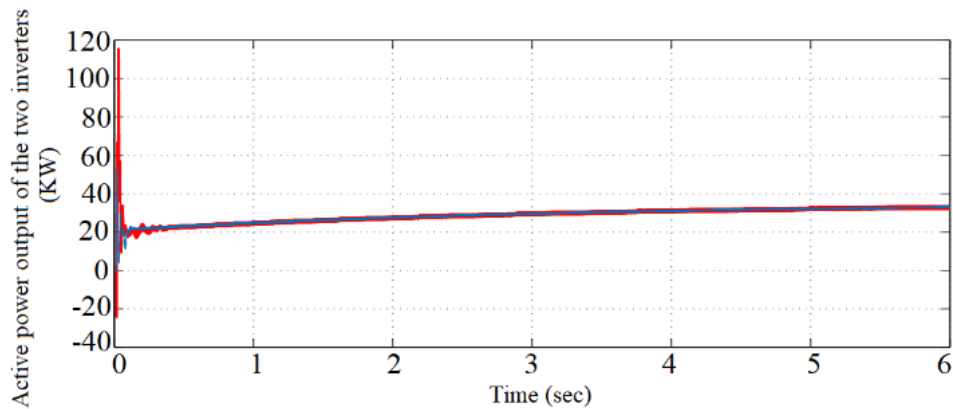

Figure 18 Active power output of the two inverters

## V. Conclusions

This article presented a method for efficient power sharing between paralleled inverters in microgrid applications. An adaptive virtual impedance has been analyzed, implemented, and tested to ensure equal/appropriate power sharing between inverters. A fuzzy controller has been proposed to replace the conventional scheme for virtual impedance estimation, which requires communication links or estimating the value of feeder impedance. The proposed fuzzy controller provides precise power sharing, eliminates the need for communication links, and provides superior performance.

## References

- [1] W. R. Issa, M. A. Abusara, and S. M. Sharkh, "Impedance interaction between islanded parallel voltage source inverters and the distribution network," in IET Conference Publications, 2014, vol. 2014, no. 2014, no.
- [2] M.S. Fathy, A. H. K. Alaboudy, and Th.ELShater, "Night operation of a photovoltaic system," proc. of the 15<sup>th</sup> international Middle East power system conference (MEPCON'12), December 23-25, 2012, paper ID 189. Alex. Egypt.
- [3] MAJID DASHTDAR, MASOUD DASHTDAR "POWER CONTROL IN AN ISLANDED MICROGRID USING VIRTUAL IMPEDANCE" Scientific Bulletin of the Electrical Engineering Faculty – Year 2020 No.1 (42)
- [4] M. Hossain, H. Pota, W. Issa, and M. Hossain, "Overview of AC microgrid controls with inverter-interfaced generations," Energies, vol. 10, no. 9, p. 1300, 2017. View at: Publisher Site | Google Scholar

- [5] W. Issa, S. Sharkh, T. Mallick, and M. Abusara, "Improved reactive power sharing for parallel-operated inverters in islanded microgrids," *Journal of Power Electronics*, vol. 16, no. 3, pp. 1152–1162, 2016. View at: [Publisher Site](#) | [Google Scholar](#)
- [6] J. M. Guerrero, L. Garcia de Vicuna, J. Matas, M. Castilla, and J. Miret, "A wireless controller to enhance dynamic performance of parallel inverters in distributed generation systems," *IEEE Transactions on Power Electronics*, vol. 19, no. 5, pp. 1205–1213, 2004. View at: [Publisher Site](#) | [Google Scholar](#)
- [7] W. R. Issa, M. A. Abusara, and S. M. Sharkh, "Impedance interaction between islanded parallel voltage source inverters and the distribution network," in *IET Conference Publications*, 2014, vol. 2014, no.
- [8] S.-J. Ahn, J.-W. Park, I.-Y. Chung, S.-I. Moon, S.-H. Kang, and S.-R. Nam, "Power-sharing method of multiple distributed generators considering control modes and configurations of a microgrid," *IEEE Transactions on Power Delivery*, vol. 25, no. 3, pp. 2007–2016, 2010. View at: [Publisher Site](#) | [Google Scholar](#)
- [9] Wenyang Deng; NingYi Dai; Keng-Weng Lao "A Virtual-Impedance Droop Control for Accurate Active Power Control and Reactive Power Sharing Using Capacitive-Coupling Inverters" *IEEE Transactions on Industry Applications* ( Volume: 56, Issue: 6, Nov.-Dec. 2020)
- [10] M. Wegmuller, J. P. von der Weid, P. Oberson, and N. Gisin, "High resolution fiber distributed measurements with coherent OFDR," in *Proc. ECOC'00*, 2000, paper 11.3.4, p. 109.
- [11] Y. Mohamed and E. F. El-Saadany, "Adaptive decentralized droop controller to preserve power sharing stability of paralleled inverters in distributed generation microgrids," *IEEE Transactions on Power Electronics*, vol. 23, pp. 2806–2816, 2008. View at: [Google Scholar](#)
- [12] M. N. Marwali, J.-W. Jung, and A. Keyhani, "Control of distributed generation systems-part II: load sharing control," *IEEE Transactions on Power Electronics*, vol. 19, no. 6, pp. 1551–1561, 2004. View at: [Publisher Site](#) | [Google Scholar](#)
- [13] I.-Y. Chung, W. Liu, D. A. Cartes, E. G. Collins, and S.-I. Moon, "Control methods of inverter-interfaced distributed generators in a microgrid system," *IEEE Transactions on Industry Applications*, vol. 46, no. 3, pp. 1078–1088, 2010. View at: [Publisher Site](#) | [Google Scholar](#)
- [14] S. T. Cady, A. D. Dominguez-Garcia, and C. N. Hadjicostis, "A distributed generation control architecture for islanded ac microgrids," *IEEE Transactions on Control Systems Technology*, vol. 23, no. 5, pp. 1717–1735, 2015. View at: [Publisher Site](#) | [Google Scholar](#)
- [15] Y. Zhang and H. Ma, "Theoretical and experimental investigation of networked control for parallel operation of inverters," *IEEE Transactions on Industrial Electronics*, vol. 59, no. 4, pp. 1961–1970, 2012. View at: [Publisher Site](#) | [Google Scholar](#)
- [16] R. Majumder, G. Ledwich, A. Ghosh, S. Chakrabarti, and F. Zare, "Droop control of converter-interfaced microsources in rural distributed generation," *IEEE Transactions on Power Delivery*, vol. 25, pp. 2768–2778, 2010. View at: [Google Scholar](#)

- [17] Ch, Sai Babu & Kumari, J. & Kullayappa, T. (2011). "Design and Analysis of Open Circuit Voltage Based Maximum Power Point Tracking for Photovoltaic System". *International Journal of Advances in Science and Technology*. 2. 51-60. *tronics*, 55, 2610-2621.
- [18] R. Issa, T. K. Mallick, and M. Abusara, "Supervisory control for power management of an islanded AC microgrid using a frequency signalling-based fuzzy logic controller," *IEEE Transactions on Sustainable Energy*, vol. 10, no. 1, pp. 94–104, 2019. View at: [Publisher Site](#) | [Google Scholar](#)
- [19] T. F. Wu, Y. K. Chen, Y. H. Huang, W. Tsai-Fu, C. Yu-Kai, and H. Yong-Heh, "3C strategy for inverters in parallel operation achieving an equal current distribution," *IEEE Transactions on Industrial Electronics*, vol. 47, no. 2, pp. 273–281, 2000. View at: [Publisher Site](#) | [Google Scholar](#)
- [20] Y. Pei, G. Jiang, X. Yang, and Z. Wang, "Auto-master-slave control technique of parallel inverters in distributed AC power systems and UPS," in *Proceedings of the 2004 IEEE 35th Annual Power Electronics Specialists Conference (IEEE Cat. No.04CH37551)*, Aachen, Germany, June 2004. View at: [Publisher Site](#) | [Google Scholar](#)
- [21] A. M. Roslan, K. H. Ahmed, S. J. Finney, and B. W. Williams, "Improved instantaneous average current-sharing control scheme for parallel-connected inverter considering line impedance impact in microgrid networks," *IEEE Transactions on Power Electronics*, vol. 26, pp. 702–716, 2011. View at: [Google Scholar](#)
- [22] Y. Xing, L. Huang, S. Sun, and Y. Yan, "Novel control for redundant parallel UPSs with instantaneous current sharing," in *Proceedings of the Power Conversion Conference-Osaka 2002 (Cat. No.02TH8579)*, Osaka, Japan, April 2002. View at: [Publisher Site](#) | [Google Scholar](#)
- [23] JFemia, N., Lisi, G., Petrone, G., Spagnuolo, G. and Vitelli, M. (2008) *Distributed Maximum Power Point Tracking of Photovoltaic Arrays: Novel Approach and System Analysis*. *IEEE Transactions on Industrial Elec*
- [24] S.-H. Hu, C.-Y. Kuo, and T.-L. Lee, "Design of virtual inductance for droop-controlled inverter with seamless transition between islanded and grid-connected operations," *2012 IEEE Energy Conversion Congress and Exposition (ECCE)*, vol. 2012, pp. 4383–4387, 2012. View at: [Publisher Site](#) | [Google Scholar](#)
- [25] J. Padhye, V. Firoiu, and D. Towsley, "A stochastic model of TCP Reno congestion avoidance and control," *Univ. of Massachusetts, Amherst, MA, CMPSCI Tech. Rep. 99-02*, 1999
- [26] Omid Abdoli , Mehdi Gholipour Rahmat-allah , Hooshmand "Improving synchronization stability of grid connected converters by virtual impedance" *IET Gener. Transm. Distrib.* 2021;15:1136–1143
- [27] T. Eram, P.L. Chapman, "Comparison of Photovoltaic Array Maximum Power Point Tracking Techniques," *IEEE Transactions on Energy Conversion*, vol. 22, no. 2, pp. 439-449, June 2007.
- [28] ] Aparna K P, Priya R, and S.Suryanarayanan, " Modeling and simulation of a PV system using DC-DC converter," *International Journal of Latest Research in Engineering and Technology (IJLRET)*, PP.09-16, vol. 1, no. 2, July, 2015
- [29] W. Issa, M. Abusara, S. Sharkh, and T. Mallick, "A small signal model of an inverter-based microgrid including DC link voltages," in *Proceedings of the 2015 17th European Conference on Power*

Electronics and Applications (EPE'15 ECCE-Europe), Geneva, Switzerland, September 2015. View at: [Publisher Site](#) | [Google Scholar](#)

- [30] W. Issa, A. El Khateb, N. Anani, and M. Abusara, "Smooth mode transfer in AC microgrids during unintentional islanding," *Energy Procedia*, vol. 134, pp. 12–20, 2017. View at: [Publisher Site](#) | [Google Scholar](#)
- [31] Abdelwahab, Saad & Hamada, Abdallah & Abdellatif, Walid. (2020), "Comparative Analysis of the Modified Perturb & Observe with Different MPPT Techniques for PV Grid Connected Systems", *International Journal of Renewable Energy Research*. 10. 155-164.
- [32] M. Abusara, J. M. Guerrero, and S. Sharkh, "Line Interactive UPS for Microgrids," *IEEE Transactions on Industrial Electronics*, pp. 1-8, Mar 2014.
- [33] H. Tao, J. L. Duarte, and M. A. Hendrix, "Line-interactive UPS using a fuel cell as the primary source," *IEEE Transactions on Industrial Electronics*, vol. 55, pp. 3012-3021, Jul 2008.
- [34] K. Ashok Reddy, Kota Srinivas and G.S. Ayyappan " Power Management in a Standalone Solar/ Fuel cell/ Battery hybrid power systems" *International Journal of Engineering Research and Development*, Volume 9, Issue 6 December 2013 .
- [35] Erkan Dursun , Osman Kilie " Comparative evaluation of different power management strategies of a stand-alone PV/Wind/PEMFC hybrid power system " *international journal of Electrical power and energy systems*. Volume 34, Januar