



Full length article

Development of a multi-purpose service machine for small areas

Zaalouk A. K.^a, Werby R. A.^{a,*}, Mousa A. M.^a, Elewa M. M.^b^a Department of Agricultural Machinery and Power Engineering, Faculty of Agricultural Engineering, Al-Azhar University, Cairo, Egypt.^b PhD student.

ARTICLE INFO

Handling Editor - Dr. Hassan A. A. Sayed

Hassan2712@azhar.edu.eg

Keywords:

A multi-purpose machine
Tillage
Chisel plow
Rotary plow
Egyptian pound (L.E.)
Depth
Bulk density

[Agricultural Machinery and Power Engineering](#)

ABSTRACT

This study aimed to develop, manufacture, and evaluate a multi-purpose machine to achieve tillage operation for smallholding farms using two developed plows (chisel plow and rotary plow). The tillage process was carried out at four different levels of forward speeds (1.2, 1.8, 3.0, and 4.4 km/h) and three depths (6, 12, and 18 cm). The results indicated that the maximum values of actual filed capacity were 0.80 and 0.91 fed/h, and field efficiency (76 and 87%) for the chisel plow and rotary plow at a forward speed of 4.4 km/h and tillage depth of 6 cm. The minimum values of power requirement were for chisel plow 1.52 and 1.25 kW and rotary plow at forward speed 1.2 km/h and tillage depth 6 cm. The maximum values of specific power were 5.36 and 4.26 kWh/fed for the chisel plow and rotary plow at a forward speed of 4.4 km/h and tillage depth of 6 cm. The optimum values of bulk soil density and soil smoothness were 987 kg/m³ and 28% at a speed of 1.8 km/h and 775 kg/m³ and 50% at a speed of 3.0 km/h for chisel plow and rotary plow at tillage depth of 18 cm. Also, the results indicated that the maximum values of penetration resistance percentage were 58% for the chisel plow and 68% for the rotary plow at a forward speed of 4.4 km/h and tillage depth of 6 cm.

1. Introduction

Smallholder farmers face many problems, including appropriate mechanization, labor shortage, increased labor wages, climate change, poor access to high genality inputs, credit, and crop marketing. Small farms face two major problems in Egypt: insufficient income and difficulty organizing into large units for social reasons (Abdelaal and Thilmay, 2019). The small-scale farms (<4 ha) occupied the largest agricultural production area (1.15 million ha) in the Delta of Egypt (Sayed et al., 2022). Vegetable crops are among the widespread crops in Egypt. They are also widespread in small areas that need appropriate mechanization. The existing agricultural machines are big, expensive, and unsuitable for smallholding farms. So, the multi-purpose machine is one of the solutions to these problems.

One of the practical solutions for reducing the tillage operations, and hence, decreasing costs, is using multitask machines (Akbarnia et al., 2013). Thakur and Jagadale (2018) developed and tested a multi-purpose tillage tool carrier with plowing and leveling. The performance evaluation of tillage tools was done with the help of a 5 hp (3.7 kW) power unit. The developed unit was evaluated by field efficiency (%), unit draft (N/cm²), power requirement (kW), energy requirement (kWh/ha), performance index (%), fuel consumption (lit/ha), field capacity (ha/h), soil pulverization (mm) and cone index (kPa) at different moisture content (6.6%, 12%, and 20%). El-Iraqi et al. (2009) modified a V-shape chisel plow and evaluated it compared to the other 2 and 3 rows. The performance tests were carried out at two different previous crops of the experimental field with two different levels of plowing depth (10 and 20 cm). The results indicated that the lowest values of

* Corresponding authors.

E-mail address: werby.rafat@yahoo.com (Werby R. A.)https://azeng.journals.ekb.eg/article_249641.1007.html

Peer review under responsibility of Faculty of Agricultural Engineering, Al-Azhar University, Cairo, Egypt.

Received 20 November 2023; Received in revised form 12 December 2023; Accepted 17 December 2023

Available online 1 January 2024

2805 – 2803/© 2024 Faculty of Agricultural Engineering, Al-Azhar University, Cairo, Egypt. All rights reserved.

draft force and the highest values of field capacity were recorded with the modified V-shape chisel plow. [Chandon and Kushwaha \(2002\)](#) reported that the draft force and tillage energy required when using a chisel plow is a linear function with operation speed directly proportional to plowing depth and width, tool characteristics, and soil properties. [Helmy et al. \(2001\)](#) reported that field capacity was affected by tillage systems and working depth. They found that field capacity was 0.91, 1.08, 1.27, and 1.33 fed/h for (moldboard plow + disc harrow), rotary plow, chisel plow one pass, and chisel plow two passes, respectively. As an active tillage tool, the rotary tiller can incorporate a range of surface-applied materials into the soil and is widely used in the above region in China. [Chaplin et al. \(1988\)](#) determined the energy consumption for tillage operations in sand-loam soil. They observed that using a chisel plow as primary tillage consumes about 60% more drawbar power than conventional tillage. [Romaneckas et al. \(2016\)](#) penetration resistance did not exceed 1 MPa for depths below 20 cm. However, they reported a continuous increase in penetration resistance value to a depth of 30 cm, and there was no further increase in penetration resistance with an increase in depth. For depths between 25 cm and 30 cm, they reported a soil penetration resistance of 3 MPa. Below 30 cm, soil penetration resistance increased more drastically, indicating that the soils were getting harder and harder down the profile.

The innovation in this research is the development of a multi-purpose machine for two types of tillage tools (chisel plow and rotary plow). The study evaluated some engineering and operating factors that affect the multi-purpose machine's performance for soil preparation for cultivating some vegetable crops in small areas.

2. Materials and methods

The present study aims to develop and evaluate a multi-purpose machine suitable for smallholding farms to perform optimum tillage, leveling, and furrow opening operations. The machine was developed in a workshop at Al-Hosayneya district, Al-Sharkeya Governorate, Egypt. The experiments were carried out at a farm at the same location during the years 2022 – 2023.

2.1. Materials

2.1.1. soil Mechanical analysis of the experimental field

The mechanical analysis of the experimental soil was performed at the Soil and Water Research Institute, Agricultural Research Center. Soil samples were collected at a depth of 30 cm using the hydrometer method. The mechanical analysis of soil in the field of experiments was at a moisture content of 15%, soil sample analysis is classified as sand 89.4%, bulk density 1500 g/cm³ and penetration resistance 20 Kg/cm².

2.1.2. The multi-purpose machine

The multi-purpose machine used in the research is suitable for small farms ([Fig. 1](#)). Various machines, namely the chisel plow and rotary plow, were adjusted before agricultural operations achieved good tillage.



Fig. 1. The multi-purpose machine.

- The multi-purpose machine consists of:

2.1.2.1. The tractor

The tractor is considered a two-wheel tractor that has a diesel engine of 6 hp and four forward speeds. Also, there is a gearbox, and the wheels take the transformation by the engine, as shown in [Fig. 2](#). [Table 1](#) illustrates the specifications of the tractor used.

Table 1

The two-wheel tractor specifications.

Item	Dimensions
Manufacture country	China
Model	MCT 550
Engine type	Diesel
Engine power	6 hp
The overall length	1850 mm
The overall width	922 mm
The overall height	1200 mm
The weight	160 kg
Starting system	Recoil
Transmission	With gear in oil path
Clutch	Dry multidisc

The tractor consists of the following components:

1. Two wheels made of rubber with dimensions of 15*35 cm.

2. A chassis made of cast aluminum, the two-wheel tractor is equipped with a gearbox, a transmission system device, and a drawbar for hitching the soil-preparing machine. The gearbox has four forward speeds and one reverse speed.

3. Two steering arms have handles to engage the wheels and steer them, and there is a fuel handle, steering, and movement separation stick.

4. The hitch device is installed on the machine's chassis with a 22 mm Benz, and the digger plow and planer are clamped with it.

5. The transmission device transmits the movement from the engine to the gearbox via a belt and tensioner.

2.1.2.2. *Plow suspension device*

The suspension device is mounted on the machine chassis by Benz at the rear of the machine. The chisel plow is suspended from it, and the horizontality of the plow is controlled through it, as shown in Fig. 3.

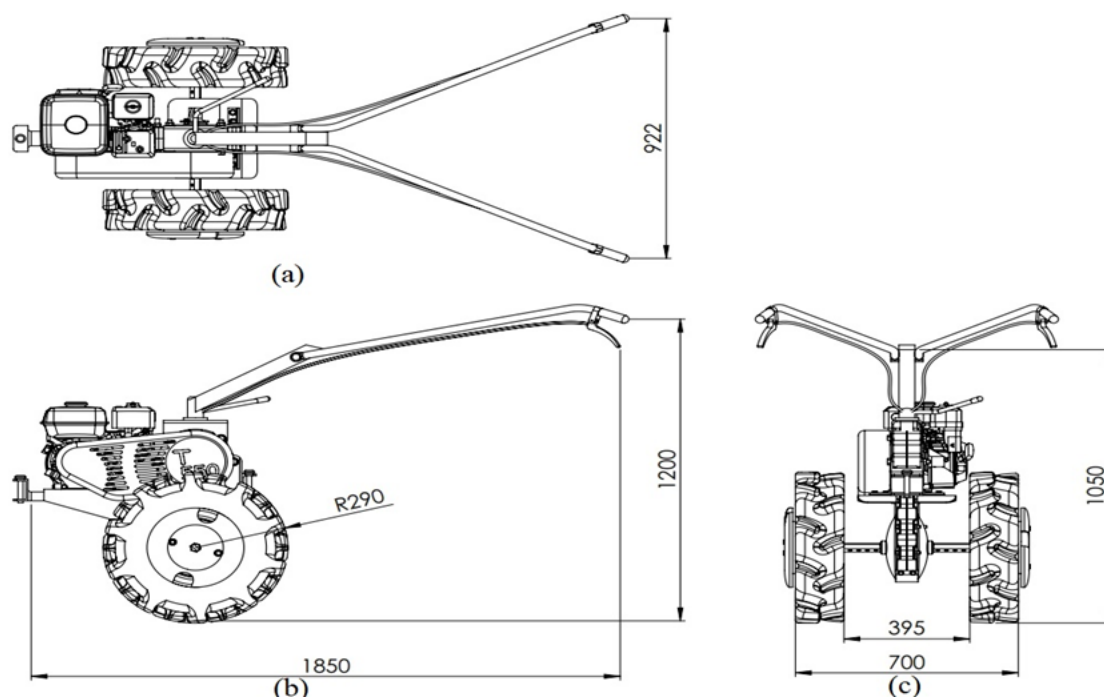

Fig. 2. The overall dimensions of the tractor (a) plane view, (b) side view, and (c) front view (dimensions in mm).

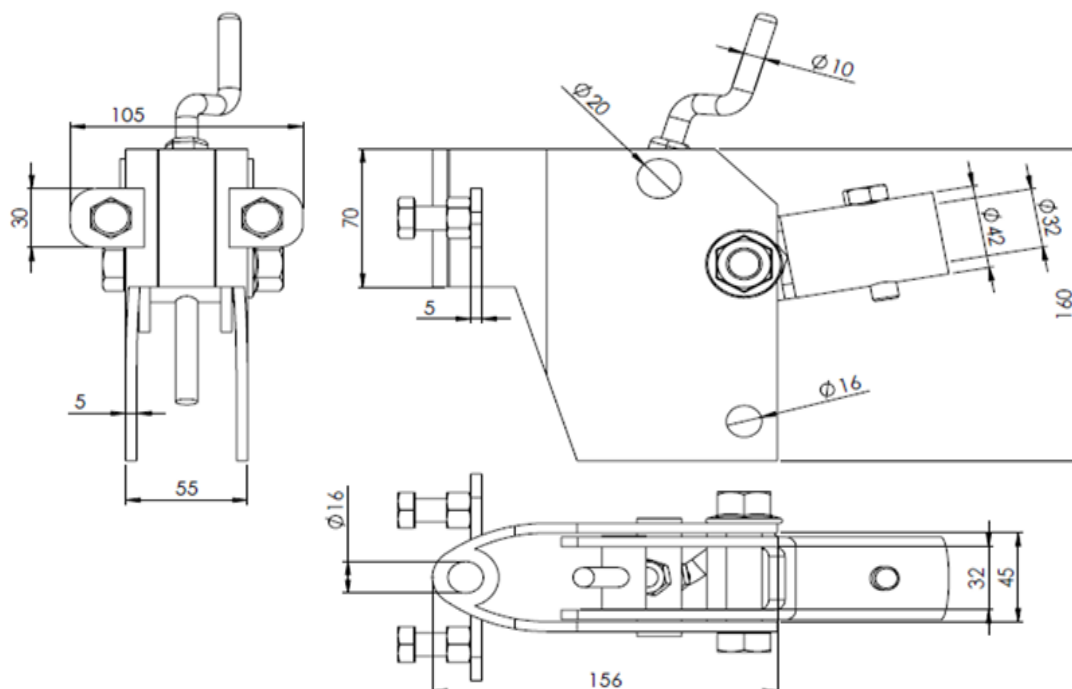

Fig. 3. The plow suspension device.

2.1.2.3. *The chisel and rotary plow attachment*

A. The chisel plow attachment was manufactured of main frame medium carbon steel with three shares, one in the front shank carrier and two in the rear shank

carrier. The dimension between the two rear shares is 700 mm width, there are two depth wheels, as shown in Fig. 4, and the specifications of the developed chisel plow are shown in Table 2.

Table 2

The specifications of the developed chisel plow.

Item	Dimensions
Dimensions of plow shank	40 * 2 * 4 cm
Material of plow shank	Medium carbon steel
Number of plow shank	Three
Type of plow share	6 * 13 cm
Dimensions of plow share	6 * 13 cm
Depth setting device	2 wheels of iron
Diameter of depth wheel	27.5 cm

B. The rotary plow was manufactured of medium carbon steel. The rotor shaft holds six blade sets; each set has three blades made of medium carbon steel. The distance between every two blade sets is 10 cm, as shown in Table 3. The rotary plow consists of a chisel share in the front middle and is attached to the

suspension device. It is installed in place of the suspension device of the chisel plow, and it works to plow the middle and control the plowing depth (Fig. 5). The second part of the rotary plow is the rotary share, which consists of two parts, a right part, and a left part, are installed in place of the wheels, and each part consists of 9 blades mounted on the rotating shaft (Fig. 6).

Table 3

The specifications of the rotary plow.

Item	Dimensions
Length of shaft	60 cm
Shaft diameter	4 cm
Number of shares	18
Length of share	20 cm
Distance between shares	10 cm

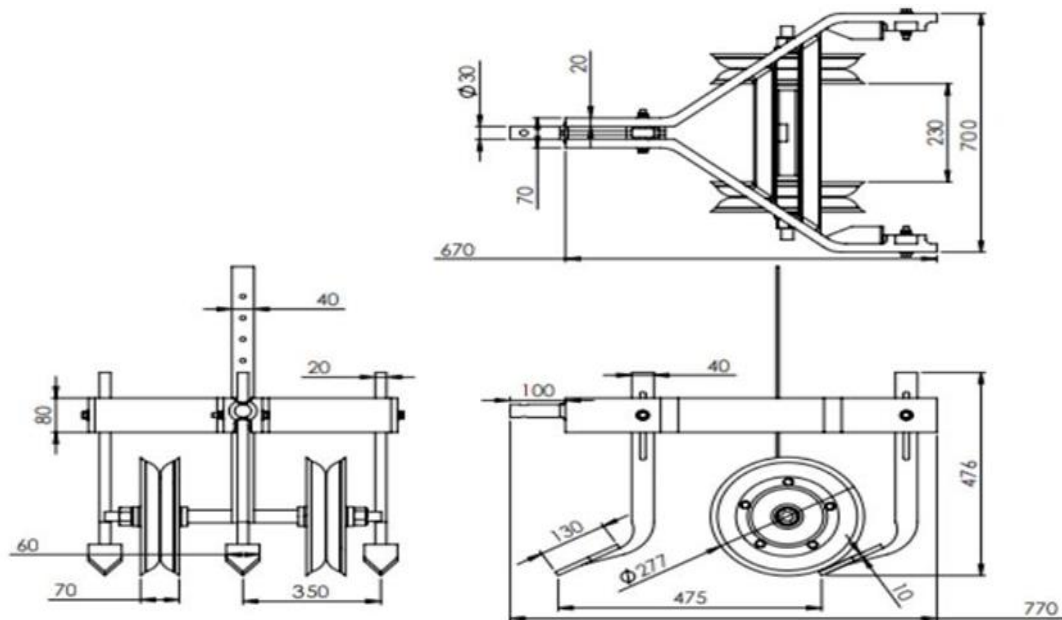

Fig. 4. The overall dimensions of the chisel plow attachment (dimensions in mm).

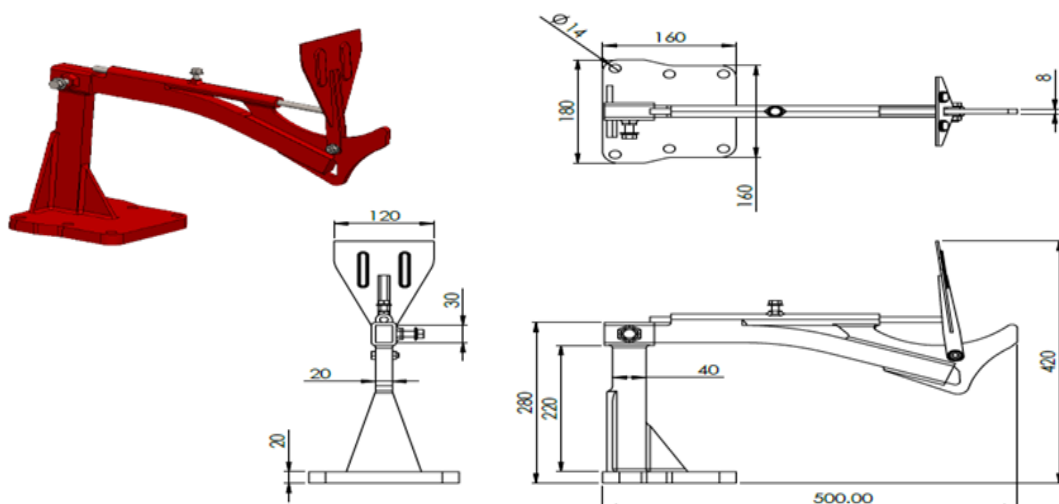

Fig. 5. The front part of the rotary plow (dimensions in mm).

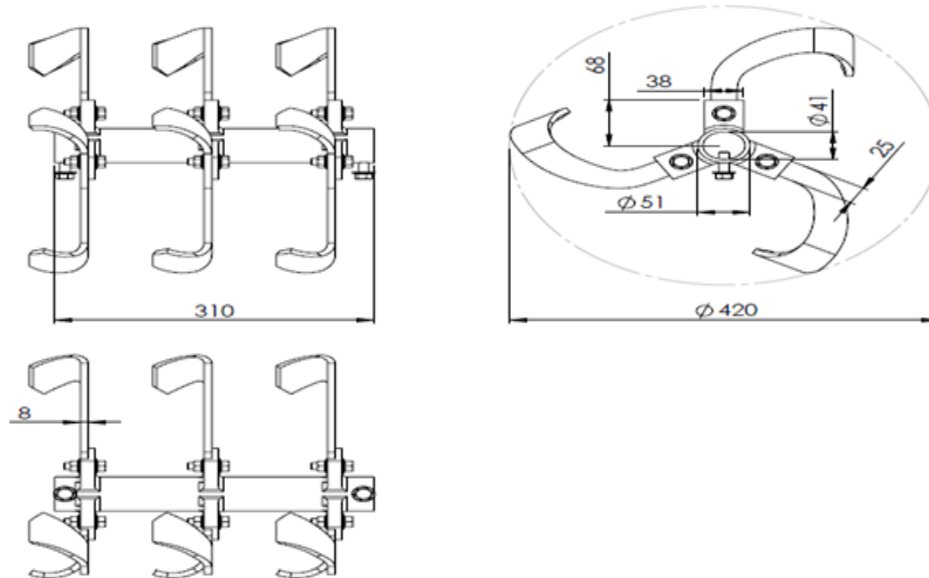

Fig. 6. The second part of the rotary plow.

2.2. Methods

2.2.1. Performance of machine

2.2.1.1. Theoretical field capacity

The theoretical field capacity is the rate of field coverage obtained if the machine performed its function 100% of the time at the rated forward speed and always covered 100% of the width (Kepner et al. 1978). It was calculated as follows:

$$T_{fc} = \frac{(W_m * S)}{4.2}$$

Where:

T_{fc} = Theoretical field capacity, fed/h.

W_m = effective width of machine, m.

S = Forward speed, km/h.

2.2.1.2. Actual field capacity

Actual field capacity is the actual average rate of coverage by machine, based upon the total effective operation time. It is a function of the rated width of the machine, the percentage of rated width actually utilized, the speed of travel, and the amount of field time lost during operation (Kepner et al. 1978). Thus, it was calculated as follows:

$$A_{fc} = \frac{1}{T_{fc} + T_L}$$

Where:

A_{fc} = Actual field capacity, fed/h.

T_L = Lost time, h/fed.

T_{fc} = Theoretical field capacity, fed/h.

This time was calculated as a percentage from the theoretical field capacity due to the conditions of the experiment: 10 % for the losses time in turning, 10% for repair maintenance, 10% for workers, etc.

2.2.1.3. Field efficiency

The field efficiency was calculated by using the following formula:

$$\eta_f = \frac{A_{fc}}{T_{fc}} * 100$$

Where:

η_f = Field efficiency, %.

A_{fc} = Actual field capacity, fed/h.

T_{fc} = Theoretical field capacity, fed/h.

2.2.1.4. Fuel consumption

The fuel consumption per unit of time was determined by measuring the volume of fuel consumed during the carryout of the different operations times. It was calculated by using the following equation:

$$F_c = \frac{V}{t} * 3.6$$

Where:

F_c = Fuel consumption rate, lit/h.

V = volume of fuel consumed, cm^3 .

t = Time of operation, sec.

2.2.1.5. Power consumption

The following formula was used to estimate the consumption power according to Embaby (1985):

$$P_c = F_c * 2.767$$

Where:

P_c = Power consumption, kW.

F_c = Fuel consumption, lit/h.

2.2.1.6. Specific power

$$P_s = \frac{P_c}{A_{fc}}$$

Where:

P_s = Specific power, kW.h/fed.

P_c : Power consumption, kW.

A_{fc} = Actual field capacity, fed/h.

2.2.2. Quality of operation

2.2.2.1. Soil bulk density

Soil samples were taken with a cylindrical core (100 cm³ volume). The core samples were immediately weighed and then dried at 105 C° for 24 hours. Soil bulk density was determined before and after every operation. The samples were collected to measure bulk density. Soil bulk density was determined according to Black et al. (1965) by using the following formula:

$$\rho_b = \frac{W_d}{V_T}$$

Where:

ρ_b = Soil bulk density, kg/m³.

W_d = Dry soil mass, kg.

V_T = Total soil volume, m³.

The percentage of the relative decrease in bulk density (%) was calculated as follows:

$$\Delta B = \frac{(B_1 - B_2)}{B_1} * 100$$

Where:

ΔB = The percentage of relative bulk density decrease, %.

B_1 = Soil bulk density before treatments, kg/m³.

B_2 = Soil bulk density after treatments, kg/m³.

2.2.2.2. Penetration resistance

A sample cone penetrometer was used to measure the penetration resistance. Soil penetration resistance was calculated according to the following formula:

$$R = \frac{S (W_1)^2}{L (W_1 + W_2) A}$$

Where:

R = Resistance of soil to compaction, kPa.

S = Disk fall distance, cm.

L = Probe penetration depth in the soil, cm for each trial.

W_1 = Disk mass, kg.

W_2 = Mass of the vertical shaft, kg.

A = The surface area of the probe, cm².

The percentage of relative decrease of soil penetration resistance (%) was calculated as follows:

$$\Delta R = \frac{(R_1 - R_2)}{R_1} * 100$$

Where:

ΔR = The percentage of relative decrease of soil penetration resistance, %.

R_1 = Soil penetration resistance before treatments, kPa.

R_2 = Soil penetration resistance after treatments, kPa.

2.2.2.3. The degree of soil smoothness

Soil samples were taken randomly from each tillage treatment by selecting a 20 cm * 20 cm area with a depth

of 18 cm where the entire soil was removed. Mesh with holes dimensions 1 cm * 1 cm and a wooden frame was used to shake samples for 30 seconds taken care to avoid the breaking of soil particles; to calculate the degree of soil smoothness, the following equation was used to measure the soil smoothness percentage:

$$S_s = \frac{W_A}{W_B} * 100$$

Where:

S_s = Soil smoothness percentage, %.

W_B = Weight of sample before shaking, g.

W_A = Weight of soil particles after shaking less than 1 cm * 1 cm of dimensions, g.

2.2.3. Total cost

2.2.3.1. Total cost per hour

The following relationship was developed by Awady (1978) to estimate the hourly cost of machine operation:

$$C = \left[\frac{P}{h} \right] * \left[\frac{1}{L} + \frac{i}{2} + t + r \right] + [1.2 * RFC * f] + \left[\frac{m}{144} \right]$$

Where:

C = Cost per hour of operation, L.E./h.

P = The initial price of the machine, L.E.

h = Yearly working hours of the machine, h/year.

L = Life expectancy of the machine, year.

i = Annual interest rate, %.

t = Annual taxes and overheads ratio, %.

r = Annual repairs and maintenance ratio for machine, %.

RFC = The actual rate of fuel consumption, lit/h.

f : Fuel price, L.E./lit.

m = Operator monthly salary, L.E./month. Factor accounting for lubrication 1.2.

144 = The operator's monthly average working hours.

- Variable numbers (In the year 2023):

P = 20000 L.E., h = 1120 hours, i = 19.25%, r = 10 %.

m = 3900 L.E./month, L = 10 years, t : 0.5%, f = 8.5 L.E./lit.

2.2.3.2. Total cost per unit area

$$T_{ca} = \frac{C}{A_{fc}}$$

Where:

T_{ca} = Total cost of unit area, L.E./fed.

A_{fc} = Actual field capacity, fed/h.

C = Cost per hour of operation, L.E./h.

3. Results and discussions

Data were obtained from the field experiments during the evaluation performance of a multi-purpose machine.

3.1. Actual field capacity

Figure 7 illustrates the relationship among the actual field capacity values "Afc" affected by forward speeds "Sa", tillage depth "Td" and plow type (chisel and rotary) "Tt". The results showed that actual field capacity increased by increasing forward speed from 1.2 to 4.4 km/h. Meanwhile, actual field capacity decreased by increasing tillage depth from 6 to 18 cm in all treatments except for some experiences, except the forward

speed of 4.4 km/h, tillage depth of 12 cm, and chisel plow, while 3 and 4.4 km/h, at tillage depth 18 cm and chisel plow and 4.4 km/h, also tillage depth 18 cm and rotary plow. The maximum value of actual field capacity was 0.91 fed/h at a forward speed of 4.4 km/h, but tillage depth of 6 cm and tillage of rotary, while the minimum value of chisel plow field capacity was 0.17 fed/h at a forward speed of 1.2 km/h and tillage depth 18 cm.

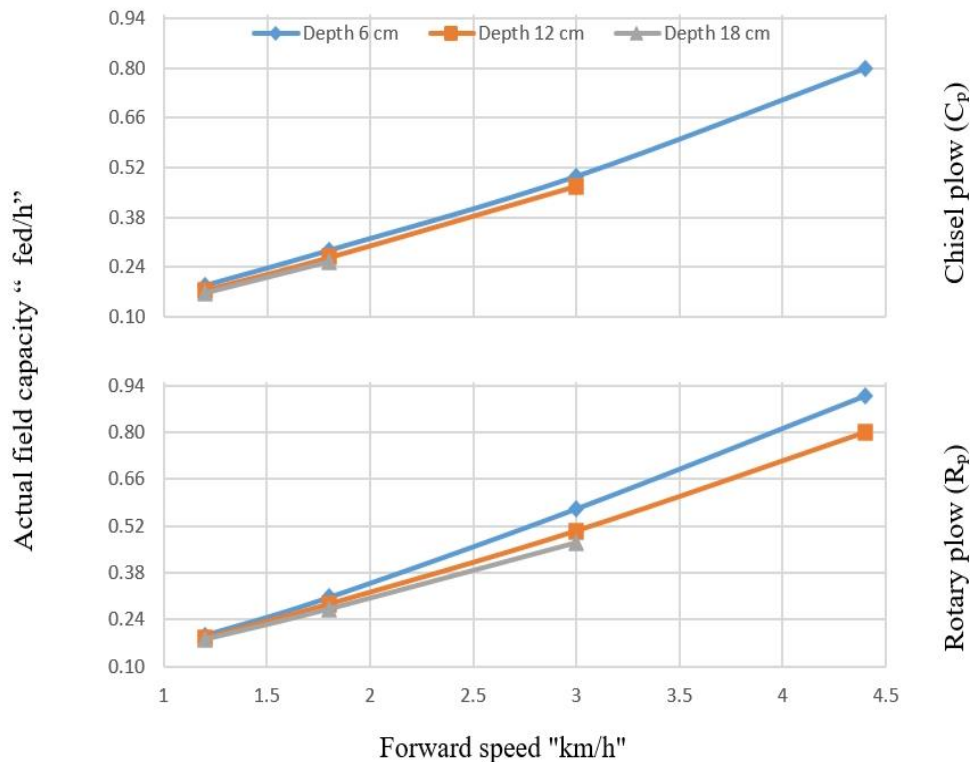

Fig. 7. Actual field capacity values Vs. forward Speeds at different tillage depths and plow-type.

3.2. Field efficiency

Figure 8 illustrates the relationship among the field efficiency (%) values affected by forward speeds "S_a", tillage depth "T_d" and plow type (chisel and rotary) "T_t". The results showed that field efficiency (%) increased if increasing forward speed from 1.2 to 4.4 km/h, while field efficiency (%) decreased if increasing tillage depth from 6 to 18 cm at different plow types in all treatments except for some experiments, they did not give results, and they are as follows: forward speed 4.4 km/h, tillage depth 12 cm and chisel plow, 3 and 4.4 km/h, tillage depth 18 cm and chisel plow and 4.4 km/h, tillage depth 18 cm and rotary plow. The maximum value of field efficiency was 87% at a forward speed of 4.4 km/h, tillage depth of 6 cm, and rotary plow, while the minimum value of field efficiency was 58% at a forward speed of 1.2 km/h, tillage depth of 18 cm and chisel plow.

3.3. Power requirement

In Figure 9, it can be noticed that when the forward speed increased from 1.2 to 3 km/h, with the chisel plow and rotary plow, the power requirement increased from

1.52 to 3.04, 1.8 to 3.60, 1.25 to 2.77, and 1.52 to 3.04 kW at 6 and 12 cm tillage depth for chisel plow and rotary plow respectively. The results also showed that when the forward speed increased was 4.4 km/h and tillage depth 6, 12, and 18 cm, the power requirement was 4.29, 0.00 and 0.00 kW, and 3.87, 4.15, and 0.00 for both chisel plow and rotary plow.

3.4. Energy requirements

In Figure 10, the maximum value of energy requirements was 16.60 kW.h/fed at a forward speed of 1.2 km/h, tillage depth of 18 cm, and rotary plow. In comparison, the minimum value of energy requirements was 4.26 kW.h/fed at a forward speed of 4.4 km/h, tillage depth of 18 cm, and chisel plow.

3.5. Soil bulk density

Figure 11 illustrates the relationship between the soil bulk density values affected by forward speeds "S_a", tillage depth "T_d", and plow type (chisel and rotary) "T_t". The results showed that bulk density (kg/cm³) decreased by increasing forward speed from 1.2 to 4.4 km/h, also bulk density decreased with increasing

tillage depth from 6 to 18 cm in all treatments except for some experiments that did not give results, and they are as follows: forward speed of 4.4 km/h, tillage depth with 12 cm and tillage, 3 and 4.4 km/h with tillage depth 18 cm and chisel plow and 4.4 km/h with tillage depth 18 cm and rotary plow. The maximum value of bulk density was 1375 kg/m³ at a forward speed of 1.2 km/h, tillage depth of 6 cm, and chisel plow. While the

minimum value of bulk density was 750 kg/m³, at a forward speed of 4.4 km/h, tillage depth of 12 cm and rotary plow decreased the bulk density kg/m³. When the forward speed increased from 1.2 to 3 km/h, with chisel plow and rotary plow the bulk density decreased from 1375 to 1312, 1125 to 1075, 1250 to 1125 and 1000 to 875 kg/m³ at 6 and 12 cm of tillage depth, respectively.

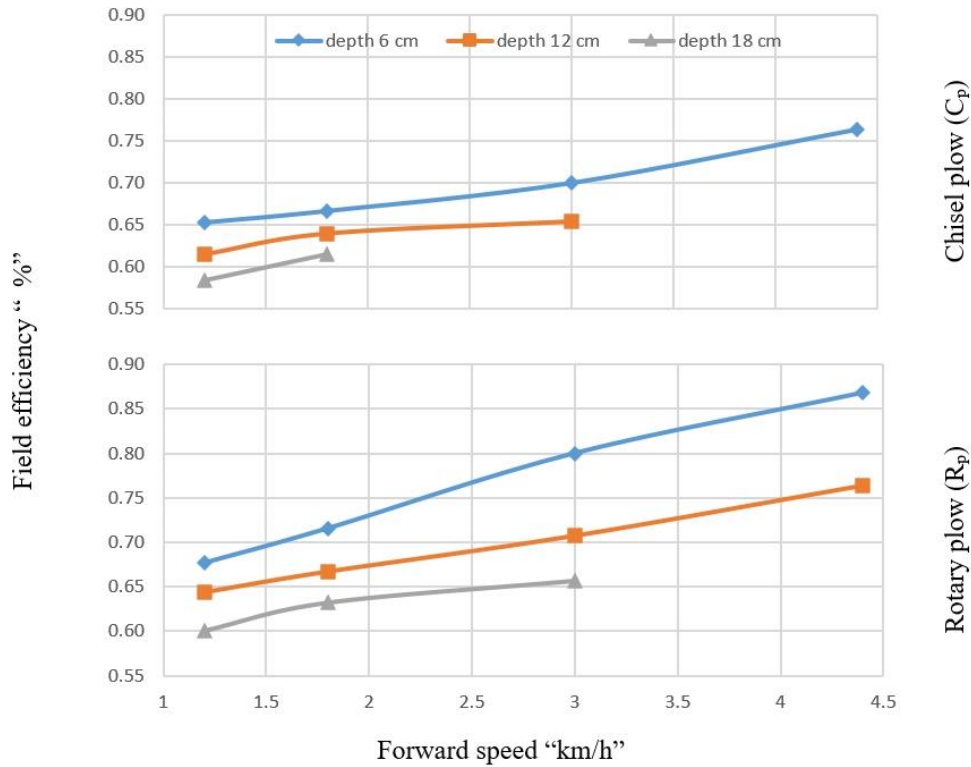

Fig. 8. Field efficiency values Vs. forward Speeds "S_a" at different tillage depths "T_d" and plow types "T_t".

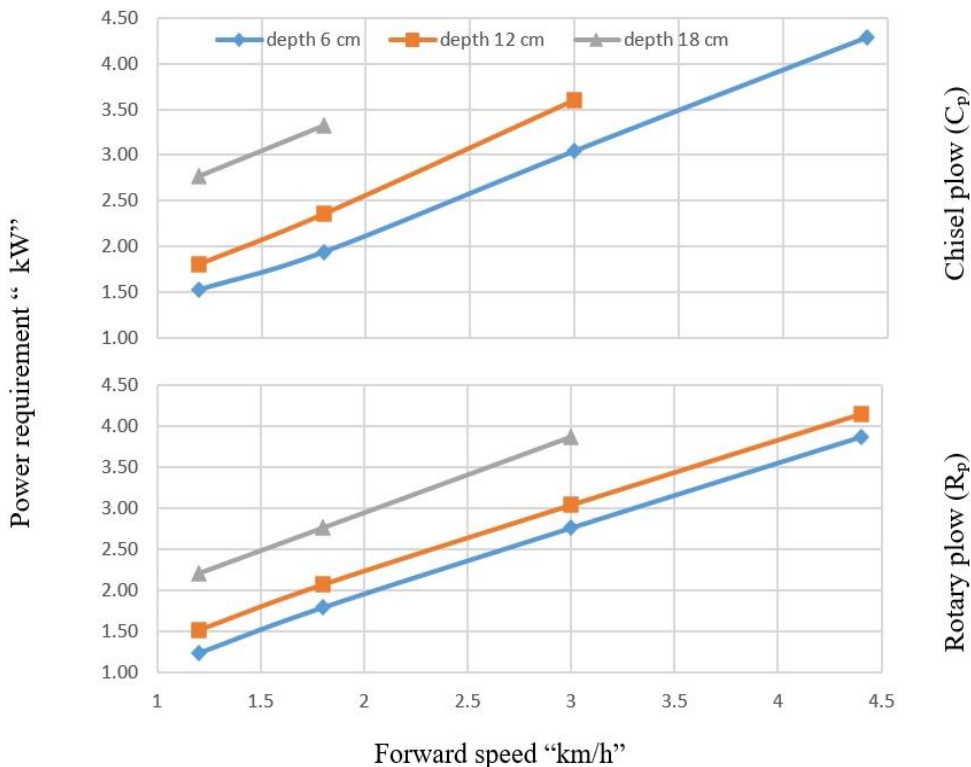

Fig. 9. Power requirement values Vs. forward Speeds "S_a" at different tillage depth "T_d" and plow type "T_t".

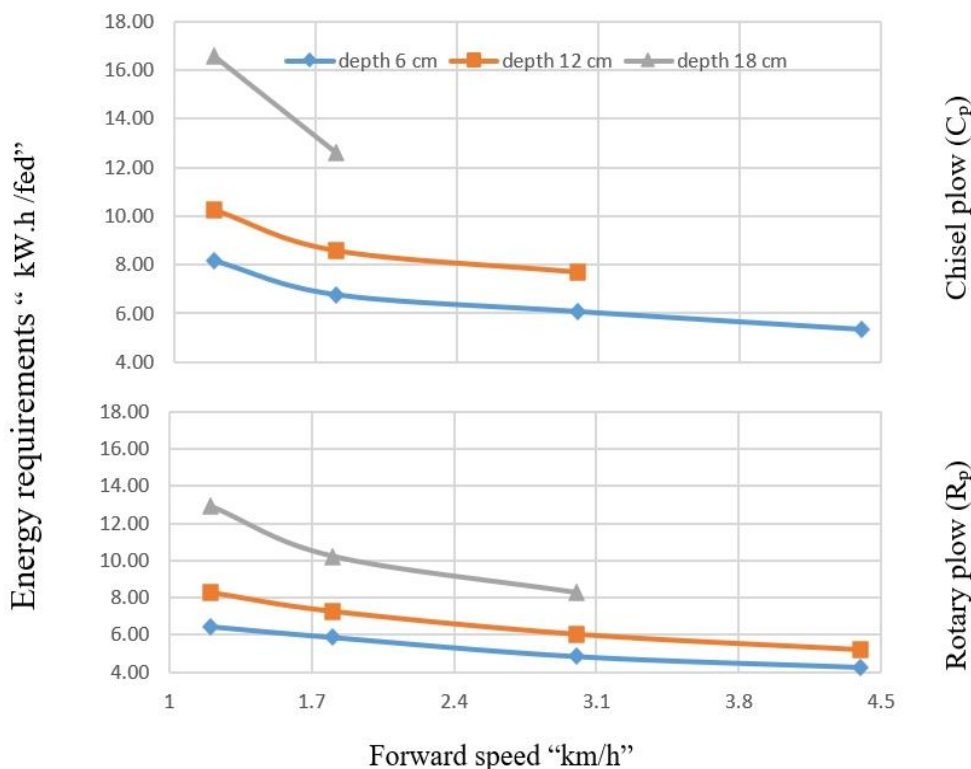

Fig. 10. Energy requirements values "Ps" at different forward Speeds "Sa", different tillage depths "Td" and plow types "Tt".

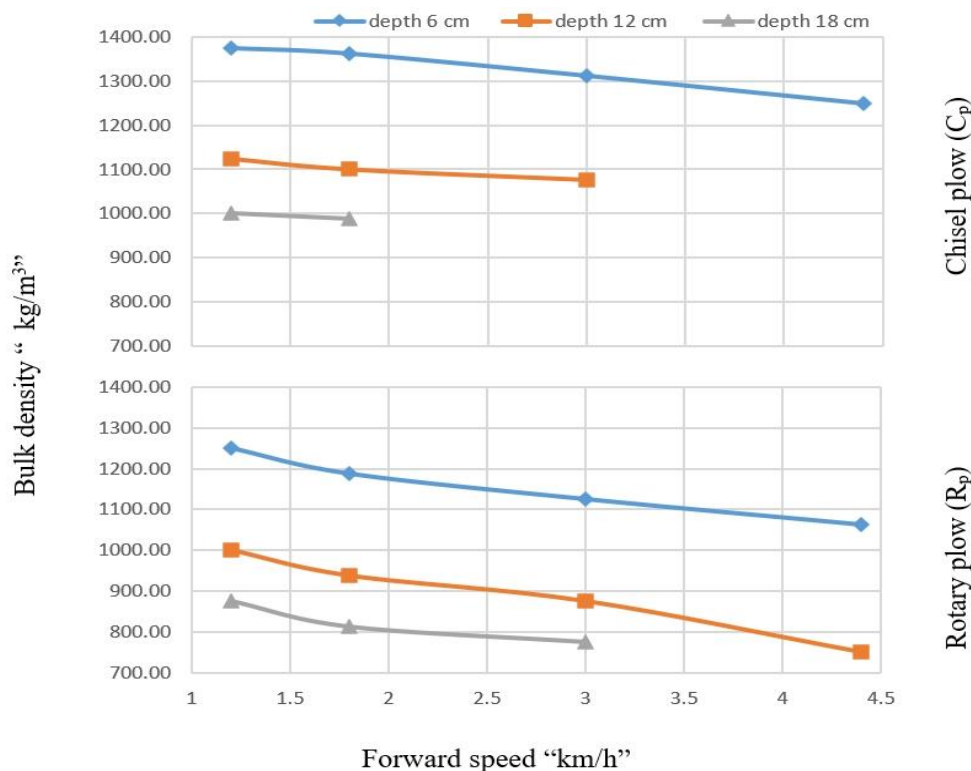

Fig. 11. Bulk density values Vs. forward Speeds "Sa" at different tillage depths "Td" and plow types "Tt".

3.6. Soil smoothness

Figure 12 illustrates the relationship among the soil smoothness "Ss" values affected by forward speeds "Sa", tillage depth "Td", and plow type (chisel and rotary) "Tt". The results showed that soil smoothness (%) increased with increasing forward speed from 1.2 to 4.4

km/h. Also, soil smoothness increased with increasing tillage depth from 6 to 18 cm in all treatments except for some experiments that did not give results; they are as follows: forward speed of 4.4 km/h with tillage depth of 12 cm and chisel plow, 3 and 4.4 km/h with tillage depth 18 cm and chisel plow and 4.4 km/h with tillage maximum depth 18 cm and plow of rotary. The maximum

value of soil smoothness was 50% at a forward speed of 3 km/h, tillage depth of 18 cm and rotary plow, while the minimum value of soil smoothness was 8% at a forward speed of 1.2 km/h, tillage depth of 6 cm and chisel plow.

3.7. Penetration resistance percentage

Figure 13 illustrates the relationship among the Penetration resistance percentage "Rp" values affected by forward speeds "Sa", tillage depth "Td" plow type (Chisel or Rotary) "Tt". The results showed that the penetration resistance percentage % increased with increasing forward speed from 1.2 to 4.4 km/h. In contrast,

penetration resistance percentage (%) decreased with increasing tillage depth from 6 to 18 cm at plow type in all treatments except for some experiments that did not yield results. They are as follows: forward speed of 4.4 with tillage depth of 12 cm and chisel plow, 3 and 4.4 km/h by tillage depth of 18 cm and chisel plow and 4.4 km/h, with tillage depth of 18 cm and plow of rotary. The maximum value of penetration resistance percentage was 68% at a forward speed of 4.4 km/h, tillage depth of 6 cm, and rotary plow, while the minimum value of penetration resistance percentage was 35% at a forward speed of 1.2 km/h, tillage depth 18 cm and chisel plow.

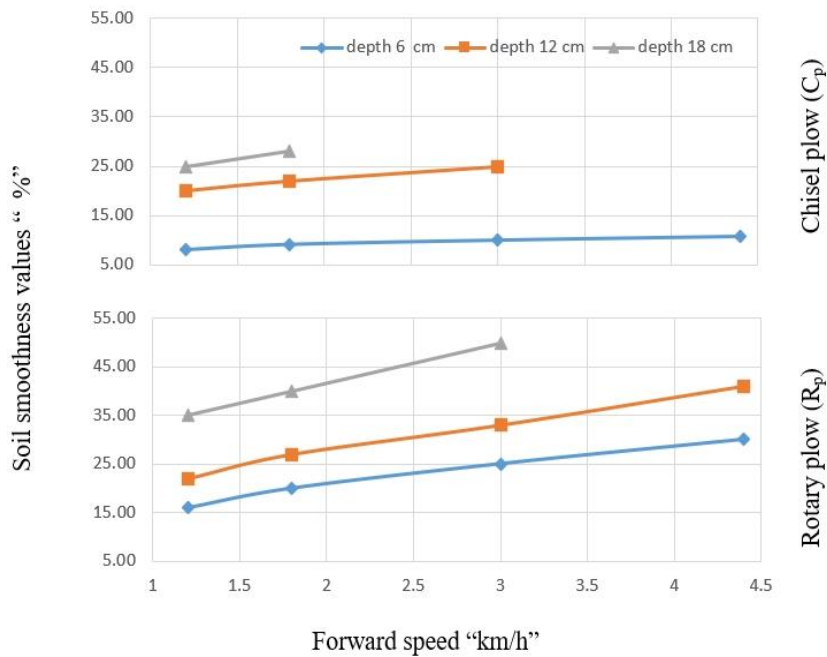

Fig. 12. Soil smoothness values Vs. forward Speeds "Sa" at different tillage depths "Td" and plow types "Tt".

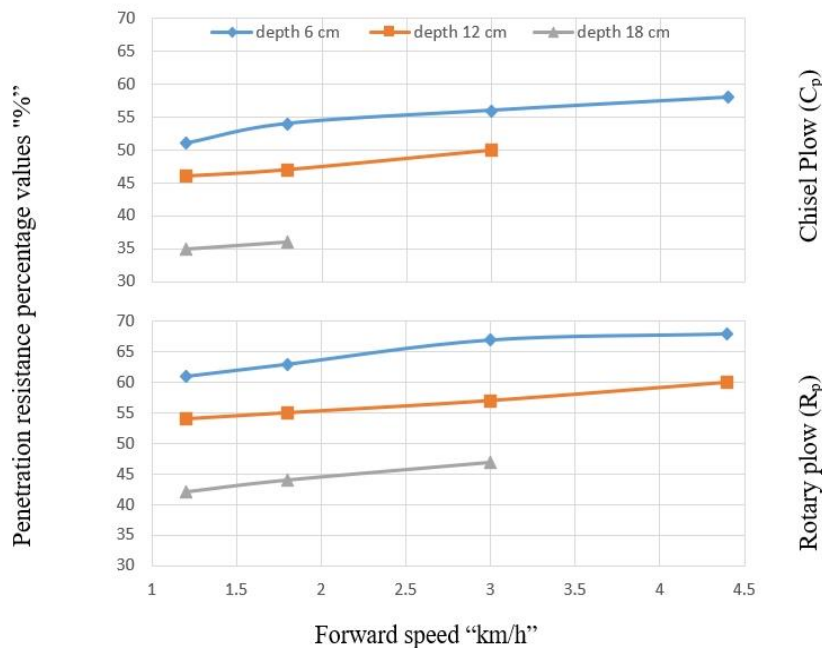

Fig. 13. Penetration resistance percentage values Vs. forward Speeds "Sa" at different tillage depths "Td" and plow types "Tt".

4. Conclusions

The operation of servicing agricultural land is considered one of the most important operations before cultivation, especially servicing small farms that are difficult to service with large machines and, therefore, require high effort and a long time to service them with human power. Given that these farms are planted with leafy vegetable crops grown throughout the year and in more than one plot, they have High economic and nutritional importance. So, this research aims to:

Developing, manufacturing and evaluating a multi-purpose machine to serve these small areas using two developed plows (three-share chisel plow, 1 m wide rotary plow). The soil plowing process was carried out at four different forward speed levels (1.2, 1.8, 3, and 4.4 km/h) and three plowing depths (6, 12, and 18 cm), and the most important results obtained were as follows:

1 -The maximum field capacity and efficiency values were 0.80, 0.91 fed/h and 76, 87% for the chisel and rotary plow, respectively, at a forward speed of 4.4 km/h and a plowing depth of 6 cm.

2 -The lowest energy consumption values were 1.52 and 1.25 kW for the drill and rotary plow on the treadmill at a forward speed of 1.2 km/h and a plowing depth of 6 cm.

3 -The maximum values of specific capacity were 5.36 and 4.46 kWh/fed for the chisel and rotary plow, respectively, at a speed of 4.4 km/h and a plowing depth of 6 cm.

4 -The optimum values for soil density and soil fineness were 988 kg/m³, 28% at a speed of 1.8 km/h and 775 kg/m³, 50% at a speed of 3 km/h for the chisel and rotary plow, respectively, at a plowing depth of 18 cm.

5- The results also indicated that the maximum values of the penetration rate were 58% for the chisel plow and 68% for the rotary plow.

References

- Abdelaal, H.S.A., Thilmany, D., 2019. Grains production prospects and long run food security in Egypt. *Sustain.* 11, 4457. <https://doi.org/10.3390/su11164457>
- Akbarnia, A., Farhani, F., Heidary, B., 2013. Economic comparison of tillage and planting operations in three tillage systems. *Agric. Eng. Int. CIGR J.*
- Awady, M. N. (1978). *Agricultural machinery, Txt, Bk., Col. Ag., AinShams Univ.: 160 p. (in Arabic).*
- Black, C.A.; D.D. Evan; J. L. White; L.E. Ensinger and F. E. Clark, (1965) *Methods of soil analysis (part), physical and mineralogical properties, including statistics of measurements and sampling*, American Society of Agronomy, Inc., pub. Madison, Wisc., U.S.A.: 375-377 and 552-557.
- Chandon, K. and R.L. Kushwaha (2002). Soil forces on deep tillage tools. *The AIC 2002 Meeting CSAE/SCGR program*
- Chaplin, J., C. Janane, and M. Lueders. 1988. Drawbar energy use for tillage operations on loamy sand. *Transactions of ASAE*, 31: 1692-1694.
- El-Iraqi, M.E., Marey, S.A., Drees, A.M., 2009. A modified V-shape chisel plow (evaluation and performance test). *Misir J. Agric. Eng.* 26, 644-666.
- Embaby, A.T. (1985). A comparison of the different mechanization system for career crop production. Master of Science thesis, agriculture engineering department, Faculty of agriculture, Cairo University.
- Helmy, M.A.; S.M. Goma; H.M. Sorour and HA. EL-Khteeb (2001). Effect of some different seedbed preparation systems on irrigation water consumption and corn yield. *Misir J. Agric. Eng.*, 18 (1); 169-181.
- Kepner, R.A. Bainer and E.L. Barger., 1978. *Principles of Farm Machinery.* 3rd ed., the AVI pub. Co., INC. Westport, CT., pp317.
- Romanekas, K., Sarauskis, E., Sakalauskas, A., & Jasinskis, A. (2016). Impact of subsoiling and scattered sowing on some soil physical properties and wheat productivity. In proceedings of the international scientific conference. Latvia University of Agriculture.
- Sayed, H., Ding, Q., Odero, A., Korohou, T., 2022. Selection of appropriate mechanization to achieve sustainability for smallholder farms: a review. *Al-Azhar J. Agric. Eng.* 2, 52-60. <https://doi.org/10.21608/azeng.2022.252902>
- Thakur, N., Jagadale, M., 2018. Development and Performance Evaluation of a Low Cost Multi-Purpose Tool Carrier with Matching Tillage Tools. *Int. J. Curr. Microbiol. Appl. Sci.* 7, 2151-2159.

تطوير آلة متعددة الأغراض لخدمة المساحات الصغيرة

أشرف كامل زعلوك^١، رأفت على ورابي^١، أحمد مصطفى موسى^١، محمود مبروك عليوة^٢

^١ قسم هندسة الآلات والقوى الزراعية، كلية الهندسة الزراعية، جامعة الأزهر، القاهرة، مصر.
^٢ باحث دكتوراه.

الملخص العربي

تعتبر عملية خدمة الأرض الزراعية من أهم العمليات قبل الزراعة وخاصة خدمة المساحات الصغيرة التي يصعب خدمتها بالآلات الكبيرة وبالتالي تحتاج إلى جهد عالي ووقت طويل لخدمتها بالأيدي العاملة ونظراً لكون هذه المساحات تزرع بمحاصيل الخضراوات والبقوليات والتي تزرع على مدار العام وفي أكثر من عروة ولها أهمية اقتصادية وغذائية عالية، يهدف هذا البحث إلى:

تطوير وتصنيع وتقييم آلة متعددة الأغراض لخدمة هذه المساحات الصغيرة بواسطة استخدام محراثين تم تطويرهما (محراث حفار ذو ثلاثة أسلحة، محراث دوراني عرضه ١ م). وقد تم إجراء عملية حرث التربة عند أربعة مستويات مختلفة للسرعة الأمامية (١، ٢، ٣، ٤، ٤، ٤ كم/س) وثلاثة أعماق حرث (٦، ١٢، ١٨ سم)، وكانت أهم النتائج المتحصل عليها كالآتي:

١- كانت القيمة القصوى للسرعة الحقلية والكفاءة (٠,٩١، ٠,٨٠، ٠,٩١ فدان/ساعة و ٧٦، ٨٧ %) للمحراث الحفار والدوراني علي التوالي عند سرعة ٤,٤ كم/س وعمق حرث ٦ سم.

- ٢- كانت القيم الأقل للطاقة المستهلكة (١,٥٢ ، ١,٢٥ ك وات) للمحراث الحفار والدوراني على التوالي عند سرعة امامية ١,٢ كم/س وعمق حرث ٦ سم.
- ٣- كانت القيم القصوى للقدرية النوعية ٥,٣٦ ، ٤,٤٦ ك وات ساعة/فدان للمحراث الحفار والدوران على التوالي عند سرعة ٤,٤ كم/س وعمق حرث ٦ سم .
- ٤- كانت القيم المثلى لكثافة التربة ودرجة نعومة التربة ٩٨٨ كجم/م^٣، ٢٨٪ عند سرعة ١,٨ ، ٧٧٥ كجم/م^٣ ، ٥٠٪ عند سرعة ٣ كم/س للمحراث الحفار والدوراني على التوالي على عمق حرث ١٨ سم .
- ٥- أشارت النتائج أيضا أن القيم القصوى لنسبة الاحتراق كانت ٥٨٪ للمحراث الحفار ، ٦٨٪ للمحراث الدوراني.