

**Military Technical College
Kobry El-Kobbah,
Cairo, Egypt**



**6th International Conference
on Electrical Engineering
ICEENG 2008**

**Utility based channel aware MIMO downlink scheduling in IEEE802.16e
broadband wireless system**

By

Suzan M.Shoukry* Khaled .F.Elsayed** Ali.El Moghazy*** Amen Nassar****

Abstract:

One of the most important features of IEEE802.16e is the ability of sophisticated QoS provisioning. The basic approach for providing the QoS guarantees in IEEE 802.16e is that the uplink and downlink scheduling at the base station (BS). To maximize usage of available resources and take advantage of the varying channel condition at the subscriber stations (SSs), adaptive and dynamic scheduling techniques are typically used. After making the scheduling decision, the BS informs all SSs about the scheduling decision at the beginning of each frame using the MAP messages. In this paper, we propose a new adaptive resource allocation and scheduling scheme for RT-downlink traffic in a single cell MIMO-based IEEE802.16e broadband wireless system. Our scheme is based on cross-layer approaches, which improves system performance in terms of increasing system throughput and provide better quality of service for users in terms of reducing Head Of Line (HOL) packet delays. We use a utility based framework to provide the link between physical layer and data link layer. In this architecture a new utility function is used. The subchannelization scheme we used is based on contiguous subcarriers in WiMAX is called band adaptive modulation and coding (AMC). To improve throughput, adaptive modulation and coding (AMC) at the physical layer is used. We provide simulation results comparing our proposal with different schemes.

-
- * Higher Technological Institute
 - ** Cairo University
 - *** Military Technical College
 - **** Cairo University

The simulation results illustrate the superiority of our scheme for different channel conditions and different numbers of active users in the system.

Keywords:

Scheduling, utility, IEEE802.16e, MIMO, cross layer, spatial multiplexing.

1. Introduction:

Recently Orthogonal Frequency Division Multiple Access (OFDMA) has been studied extensively as a multiple access technique for high data rate transmissions over wireless radio channels. In OFDMA, the available spectrum is divided into multiple orthogonal narrowband subchannels (subcarriers) and information symbols are transmitted in parallel over these low-rate subchannels. This method results in reducing inter-symbol interference (ISI), and multipath delay spread, and thus improves the capacity [1].

Multiple Input Multiple Output (MIMO) technology has also been recognized as a key approach for achieving a dramatic increase in the capacity of wireless systems [2-4]. One technique of MIMO technology is the space-time coding (STC). STC, such as Alamouti scheme [5,6], achieves spatial diversity gain and reduces fade margin. The other technique is spatial multiplexing (SM), where multiple streams are transmitted over multiple antennas [7,8]. Both MIMO techniques can increase the transmission rate compared to Single Input Single Output (SISO) channels. The use of MIMO technology combined with OFDMA is an attractive solution for future broadband wireless system.

The IEEE802.16e standard for broadband wireless solution enables convergence of mobile and fixed broadband networks through a common wide area broadband radio access technology and flexible network architecture [9]. IEEE802.16e is an enhancement to IEEE 802.16d standard to support subscriber stations moving at vehicular speeds and thereby specifies a system for combined fixed and mobile broadband wireless access [10].

For improving performance, IEEE802.16e combines scalable-OFDMA (S-OFDMA)¹, and MIMO communication at the physical layer. IEEE802.16e supports a full range of MIMO technologies to enhance system performance. At the same time, it supports adaptive switching between these technologies through adaptive MIMO switching (AMS) between multiple modes.

One of the crucial problems of IEEE802.16e is the allocation and management of radio resource. This problem has a direct impact on the overall performance of IEEE802.16e

¹ scalable means that it is designed to be able to scale to work in different channels from 1.25 to 20 MHz

network. In fact, the allocation and management of radio resources is a scheduling problem. The scheduler determines all users allocations and the quantity of packets that should be scheduled for each subchannel in the current frame. To improve the performance, the MAC scheduler must efficiently allocate available resources in response to both bursty traffic nature and time varying wireless channel.

A new trend in the design of wireless scheduling is the cross layer design. Cross layer design refers to the need for interaction and information exchange between the physical and higher layers to account for the volatile and time-varying nature of the wireless medium [11]. One of the architectures of the cross layer resource management is utility-based scheduling. In the utility-based scheduling architecture a utility function is a generic mathematical tool that can be designed to capture QoS, channel state, and current state of the user backlog. A utility function is used to represent the customer level of satisfaction of the service received from the system. Typically, different applications would have different utility functions.

In this paper, we present a utility based downlink scheduling and resource allocation for real-time polling services (rt-PS) traffic in a single cell MIMO-based IEEE802.16e broadband wireless system. We use adaptive modulation and coding (AMC) to supply multiple supportable data rates based on the channel state information at the receiver which feedback through uplink CQICH² channel which provides fast channel information feedback.

The rest of this paper is organized as follows. In section 2 we present the previous work related to our study. Our system model is described in section 3. We state the problem formally and present our scheme in section 4. The simulation and results are shown in section 5. Finally the conclusions are provided in section 6.

2.Related work

The area of dynamic resource allocation and scheduling for OFDMA based systems has been a hot area recently due to the introduction of OFDM based wireless systems such as IEEE802.16e and Long Term Evolution (LTE) of 3GPP. In[12] the authors consider non iterative base-station allocation of subcarriers and power to each user to maximize the sum of users data rates subject to constrains on total power, and bit rate. In [1] a new fairness criteria among users is considered, which is a generalized proportional fairness based on Nash bargaining solutions and coalition. In [7] the authors attempt to solve the problem of maximizing the total packet throughput subject to individual user's QoS

² the uplink subframe has a channel-quality indicator (CQICH) for the SS to feed back channel-quality information that can be used by the base station (BS)

requirements while assuming finite buffers for the arrival of packets. In [13] the authors consider the problem of dynamic resource allocation and scheduling with the objective of increasing the number of non real time service users that can be supported in the system. In [14] the author presents new criteria to evaluate a particular network architecture, which must be designed to maximize the performance of the resident applications. In this regard the authors present the utility function which maps the service delivered into the performance of the application. Thus a new concept in scheduling is to maximize the sum of the utilities, and this is known as utility-based resource allocation and scheduling approach. The work presented in [15] was built on a utility optimization based architecture which was able to effectively enhance spectral efficiency and guarantee QoS. In [16] the authors presented a scheme to achieve reliable data transmission rate. Therefore they use utility function which is a non decreasing function of throughput. In [17] the authors propose a new scheduling algorithm that is able to schedule RT, and NRT traffic at the same time and this scheduling algorithm uses time utility function as an urgency factor.

There has been work in the literature to extend the work of dynamic resource allocation and scheduling in OFDMA systems into the systems which support MIMO channels. In [15] the authors develop a new scheduling algorithm for MIMO/OFDMA system. This scheduling aimed to maximize system throughput while guaranteeing minimum data rates requirements for multimedia users. The authors in [16] modify the generalized proportional fair (GPF) scheduling algorithm to the Weighted Proportional Fair (WPF). This scheduling algorithm can achieve fairness performance as that of GPF scheduling algorithm.

Our contribution in this work is that we apply the utility based resource allocation and scheduling in the MIMO/OFDMA system. We develop a new utility function which takes into consideration users' requirements such as the HOL packet delay and the required packet dropping ratio. Our proposed algorithm is also channel aware since it uses the channel information in making the scheduling decision. The users' backlogged queues information is also considered in the scheduling.

3.system model

We consider a single cell based on IEEE802.16e with MIMO support .Let N_R , N_T be the number of receive and transmit antennas in the MIMO system, and let K be the number of OFDM subcarriers, and let I be the number of users. Figure 1 presents the used system model we use in our work. In our system the scheduling decision is made at the BS. The scheduler is located at the BS to enable fast response to traffic requirements and channel conditions. The scheduler at the BS uses the channel state information from the receiver side, the connection QoS parameters, and the users' queue information to decide antennas and subchannels allocation. After the assignments of antennas and subcarriers adaptive modulation and coding is

performed. Finally IFFT is done to transform users' symbols into time domain to be transmitted through the channel. We use Time Division Duplex (TDD) frame structure as shown in figure 2, where the frame is divided into Uplink (UL) and Downlink (DL) sub-frames separated by Transmit/Receive and Receive/Transmit transition gaps (TTG and RTG, respectively) to prevent DL and UL collisions. For improving system operation each frame includes some control information, some of which are in the DL subframe and the others are in the UL subframe

The control information in the DL subframe includes:

- **Preamble:** which is used for synchronization, it is in the first OFDM symbol of the frame
- **Frame Control Header (FCH) :** it provides the frame configuration information
- **DL-MAP and UL-MAP:** they provide subchannel allocation and other control information for the DL and UL subframes respectively.
- **DCD, UCD:** BS also transmits the downlink channel descriptor (DCD) and the uplink channel descriptor (UCD) following the UL-MAP message, which contains additional control information pertaining to the description of channel structure and the various burst profiles that are allowed within the given BS. In order to conserve resources, the DCD and the UCD are not transmitted every DL frame.

The control information in the UL subframe includes:

- **UL Ranging Allocation:** is allocated for mobile stations (MS) to perform closed-loop time, frequency, and power adjustment as well as bandwidth request.
- **UL CQICH Allocation:** is allocated for the MS to feedback channel-state information.
- **UL ACK:** is allocated for the MS to feedback DL Hybrid Automatic Repeat request (HARQ) acknowledgements.

In each frame, we assume that the data in the DL subframe is transmitted from the start of the symbol number η while the symbols 0 to $\eta-1$ are completely reserved for the preamble, FCH, DL-MAP, and UL-MAP.

In IEEE802.16e subcarriers are grouped into subchannels. There are two types of grouping subcarriers (permutation), which are as described in [10]. The first one is diversity permutation, in which the subcarriers are grouped in a pseudo-random way (PUSC)³. The second permutation is the contiguous permutation, in which a block of contiguous subcarriers are grouped to form a subchannel. Our system is based on the second type of permutation, which is known as band Adaptive Modulation and Coding (AMC) permutation. In this subcarrier permutation, nine adjacent subcarriers with eight data subcarriers and one pilot subcarrier are used to form a bin, as shown in Figure 3.

A slot in AMC is defined as a collection of bins of the type $(B * S=6)$ where B is the partial usage of subcarrier

number of contiguous bins and S is the number of contiguous symbols. In our system we take 6 bins in 1 symbol to form AMC subchannel

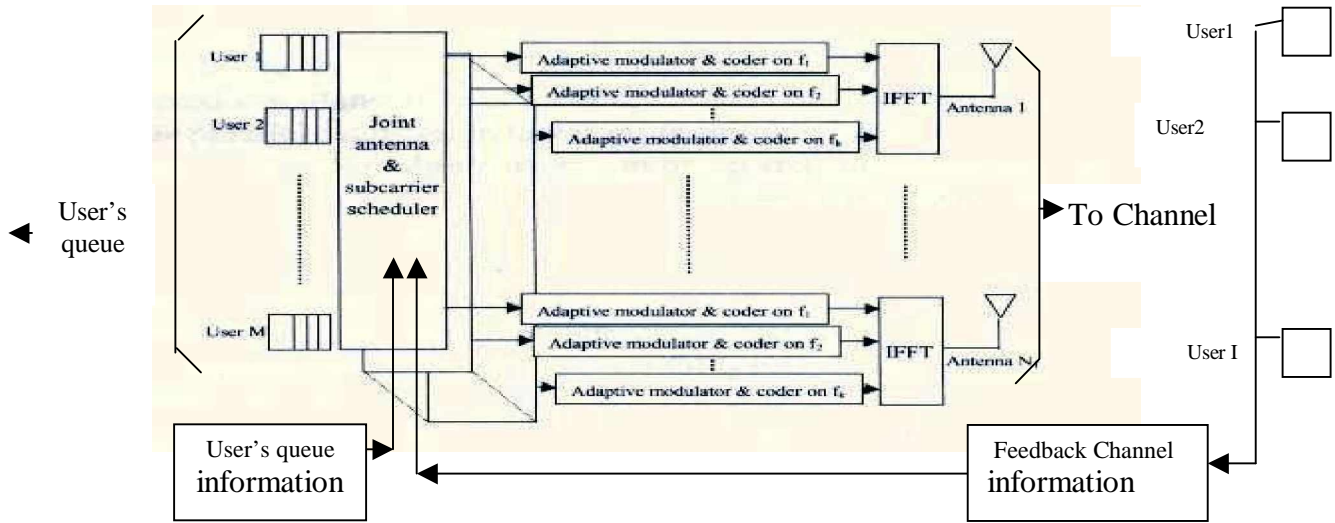

Figure (1):system model

Our system is based on spatial multiplexing MIMO technology, in which, and for recovery requirements N_T and N_R must satisfy that $N_R \geq N_T$.

We assume that the transmitted power is equally allocated to the transmit antennas and subcarriers. For the channel model, we follow the channel model of OFDM based spatial multiplexing system given in [17]. Where we model the delay spread by assuming that there are L significant scattered clusters as shown in Figure 4 and that each of the paths emanating from within the same scattered cluster experiences the same delay. Let H_l be $N_R \times N_T$ complex-valued random matrix, which represents the l^{th} tap of the discrete-time MIMO fading channel impulse response. The elements of the individual H_l are circularly symmetric complex Gaussian random variables. Different scatterer clusters are uncorrelated, i.e;

$$E[\text{vec}\{H_l\}\text{vec}^H\{H_l\}] = 0_{N_R \times N_T} \tag{1}$$

Where

$$\text{Vec}\{H_l\} = [h_{l,0} \quad h_{l,1} \quad \dots \quad h_{l,N_T-1}] \tag{2}$$

With $h_{l,n} = [h_{l,n}^{(0)} \quad h_{l,n}^{(1)} \quad \dots \quad h_{l,n}^{(N_R-1)}]^T$ denoting the n^{th} column of the matrix H_l , and $0_{N_R \times N_T}$ denoting the all-zero matrix of size $N_R \times N_T$. Each scatterer cluster has a mean angle of arrival at the BS denoted as $\bar{\theta}_l$, a cluster angle spread δ_l (proportional to the scattering radius of the cluster), and a path gain σ_l^2 (derived

from the power delay profile of the channel).

$$H(e^{j2\pi l k/N}) = \sum_{l=0}^{L-1} H_l e^{-j2\pi l k/N}$$

And let

$$c_k = [c_k^0, c_k^1, \dots, c_k^{N-1}] \tag{3}$$

Be the transmitted symbol, where

c_k^j denoting the data symbol transmitted from the j^{th} antenna on the k^{th} subchannel ($k=0,1,\dots,K-1$).

$$c = [c_0^T, c_1^T, \dots, c_{K-1}^T]$$

$x = [x_0^T, x_1^T, \dots, x_{K-1}^T]$ where x_k is the reconstructed data vector for the k^{th} subcarrier.

$n = [n_0^T, n_1^T, \dots, n_{K-1}^T]$, n_k is the Additive White Gaussian Noise AWGN vector.

Then

$$x_k = H(e^{j2\pi k/N}) c_k + n_k \tag{4}$$

At the receiver and in order to recover the transmitted symbol, the receiver weight matrix G_k is generated and hence, G_k is applied as follows

$$y_k = G_k x_k \tag{5}$$

$$y_k = G_k H_k c_k + G_k n_k \tag{6}$$

In our system, we assume Zero Forcing (ZF) receiver. Where G_k is defined as [12]

$$G_k = (H_k)^H (H_k H_k^H)^{-1} \tag{7}$$

Where $(.)^H$ denotes the complex conjugate transpose.

In order to take into consideration the receive antenna diversity the receiver gets the post-processing SNR.

The post processing SNR for subcarrier k on antenna n_t is given by [18]

$$SINR_{k,nt} = \frac{|g_{K,nt}^* h_{K,nt}|}{N_O \|g_{K,nt}\|^2 + \sum_{j \neq nt} |g_{K,nt}^* h_{K,j}|^2} \tag{8}$$

where

$g_{K,nt}$ denote the nt row of G_k

$h_{K,nt}$ denote the nt column of H_k

Within the framework of IEEE802.16e, the receiver calculates this value of post processing SNR and quantizes it from -16 dB to 47.5 dB in units of 0.5dB. This value is then feedback to the base station in 7 bits using the UL Channel Quality

Indicator Channel “CQICH”. The base station uses this value to choose an appropriate burst profile, namely the proper modulation and code rate as shown in table 1 [10].

Table (1): Adaptive modulation and coding

Modulation	Code rate	SINR
BPSK	1/2	13.9
QPSK	1/2	16.9
QPSK	3/4	18.65
16QAM	1/2	23.7
16QAM	3/4	25.45
64QAM	1/2	29.7
64QAM	3/4	31.45

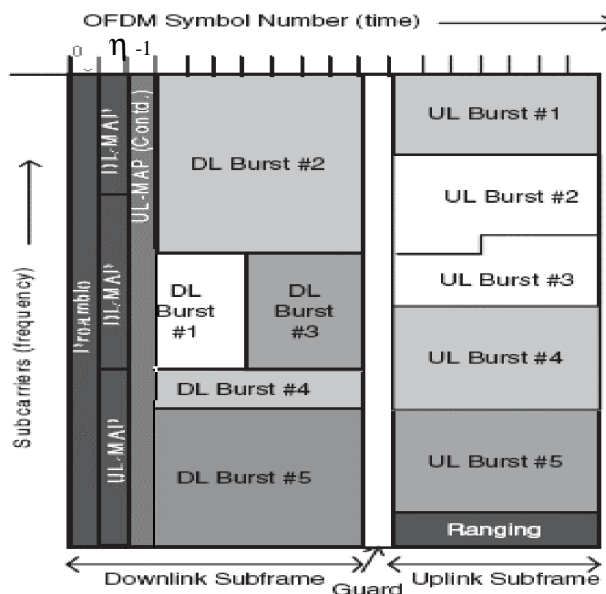

Figure(2): Time plan - one TDD time frame (with only mandatory zone) used in our

simulation

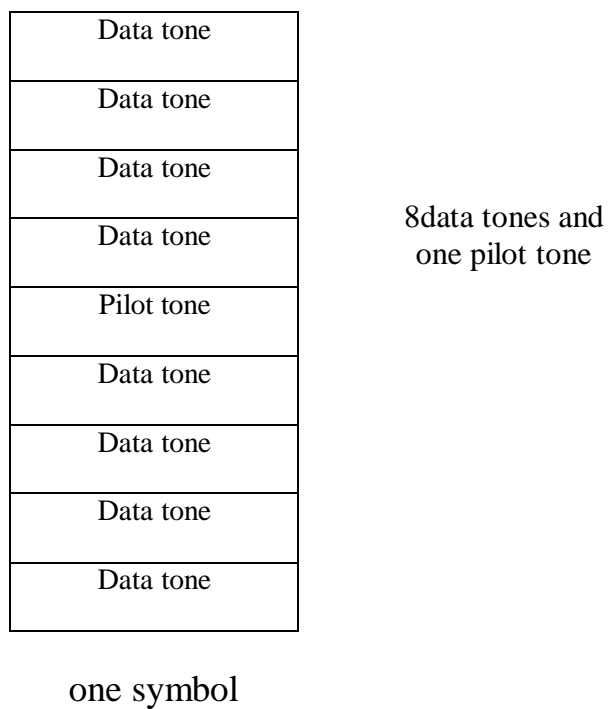

Figure(3):bin structure

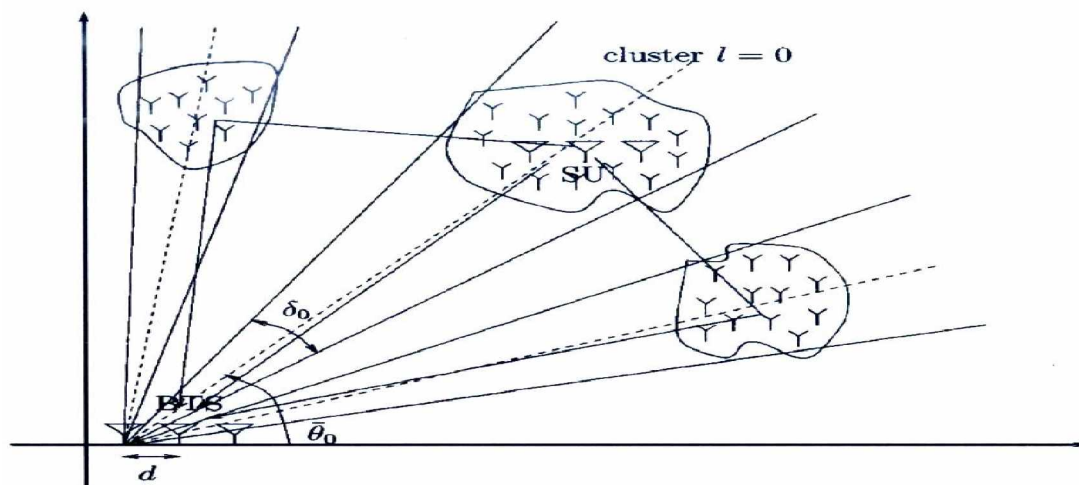

Figure(4):Channel model[20]

4. problem formulation and the proposed utility-based scheduling scheme

The scheduling and resource allocation decision can be viewed as selecting which user is assigned which subchannel and is performed every frame. We assume that, subchannels is assigned to users for the full frame duration.

Let $w_i(m)$ be the average waiting delay for the Head Of Line (HOL) packet in queue of user i at frame m .

Our scheduling is based on a new utility function $U_i(w_i(m))$, which reflects the customer level of satisfaction received from the system.

We define $U_i(w_i(m))$ as a decreasing function in the $w_i(m)$ thus large value of $U_i(w_i(m))$ means small delay and hence better satisfaction of the real time user. The utility function is given by:

$$U_i(w_i(m)) = \frac{e^{-q_i(w_i(m) - D_i^{\max})}}{1 + e^{-q_i(w_i(m) - D_i^{\max})}} \quad (9)$$

Where

D_i^{\max} is the maximum allowed delay of user i .

We define q_i as a quantization constant which indicates the emergency of the traffic of user i according to its required Packet Dropping Ratio (PDR) as follows:

We assume that the system support 10 levels of PDR as shown in Table2.

We define the constant q_i as the level number divided by the total number of supported levels in the system.

$$q_i = \frac{\text{level_number}}{\text{total_number_of_levels_in_the_system}} .$$

As we see ,as the level number of the flow i decrease the flow must have higher priority

During the current frame, and starting from symbol η till end of frame let us define a constant $\beta_{k,n,i}$ where, $\beta_{k,n,i}=1$ if subchannel k on transmitted antenna n is assigned to user i otherwise $=0$, where $k=0,1,\dots,K-1$, $n=0,1,\dots,N_T-1$

Now the optimization problem can be written as

$$\max \sum_i U_i(w_i(m)) \quad (10)$$

subject to

$$w_i(m) \leq D_i^{\max} \quad (11)$$

$$\sum_i \sum_K \sum_n \beta_{K,n,i} = 1 \quad (12)$$

Table (2) different levels of supported PDR in the system

PDR	Level number	q
1-0.1	10	1
10^{-1} - 10^{-2}	9	0.9
10^{-2} - 10^{-3}	8	0.8
10^{-3} - 10^{-4}	7	0.7
10^{-4} - 10^{-5}	6	0.6
10^{-5} - 10^{-6}	5	0.5
10^{-6} - 10^{-7}	4	0.4
10^{-7} - 10^{-8}	3	0.3
10^{-8} - 10^{-9}	2	0.2
Less than 10^{-9}	1	0.1

The long term optimization objective with respect to average waiting time leads to instantaneous optimization objective for each subchannel k [19]. thus our optimization problem tends to that at each frame m , our scheme assigns subchannel k on transmitted antenna n to user i that satisfy

$$i^* = \arg \max_{i \in I} |U'(w_i(m))| \min(R_{i,k,n}(m), Q_i(m)/T_S) / \bar{R}_i(m) \quad (13)$$

where:

$U'(w_i(m))$ is the first derivative of $U(w_i(m))$

$R_{i,k,n}(m)$ is the achievable rate for user i if it were assigned subchannel k on transmitted antenna n at frame m

$\bar{R}_i(m)$ is the updated average throughput of user i at frame m as given by

$$\bar{R}_i(m) = (1-1/t_c) \bar{R}_i(m-1) + \sum_K \sum_n \beta_{K,n,i} (1/t_c) R_{i,k,n}(m-1) \quad (14)$$

t_c is a low pass filtering parameter. We take $t_c = 1000$ as recommended in [18].

T_S is the frame length in sec.

$Q_i(m)$ is the queue length of user i at frame m .

The $\min(x,y)$ function is used to make sure that the service bits allocated to each user should be less than or equal to the accumulated bits in its queue to avoid bandwidth wastage [20].

5. Performance Evaluation:

In our simulation we consider a single cell of 1Km radius 2X2 MIMO system. Users are assumed to be uniformly distributed across the cell. The relative antenna

space $\Delta=0.5$, the average angle of arrival $\bar{\theta}_l = \Pi/2$, and $\sigma_{\theta_l} = 0.25$ ($l=0, 1, \dots, L-1$), where $L=6$.

We assume $\eta=3$ thus data are transmitted from the beginning of symbol 3 in the DL subframe. The rtps traffic is assumed to be RT video streaming service, which periodically generates packets of variable sizes [20]. In our simulation we assume that the maximum allowed delay is 250ms. The accepted PDR is 0.01, and hence $q_i=0.9$. We run the simulation for 10 min. which is equivalent to 120000 frames each of 5 msec.

We follow the system parameters as given in Table 3

Table (3) summery system parameters used in simulation

System channel bandwidth (MHZ)	5
FFTsize	512
Sub-carrier frequency spacing (KHz)	10.94
Carrier freq (GHz)	2.3
Frame length (ms)	5
DL/UL ratio	3:1
OFDMA symbol time (μ^s)	100.84
Number of OFDMA symbols per frame	49
TTG (μ^s)	29.41
RTG (μ^s)	29.41
Number of OFDMA symbols per frame (DL)	36
Number of OFDMA symbols per frame (UL)	12

In order to make a good assessment of our proposed scheduling scheme (described in section 4) we compare the performance with two well known scheduling schemes. The first is the Modified Largest Weighted Delay First (MLWDF) [17] whose design objective is to maintain the delay of each traffic flow smaller than a predefined threshold value with some probability.

$$i^* = \arg_{i \in I} \max \gamma_i w_i(m) R_i(m) \tag{15}$$

where

$$\gamma_i = a_i / \bar{R}_i(m)$$

$$a_i = -\log(\delta_i) / D_i^{\max}, \text{ where } \Pr\{ W_i(m) \leq D_i^{\max} \} \leq \delta_i$$

$w_i(m)$ is the head of line packet delay of frame m

and $\bar{R}_i(m)$ is the average channel rate of frame m and is evaluated as in equation

(14)

The second scheduling scheme is the Channel State Dependent Scheduling (CSDS) algorithm in which the design objective is to assign each subchannel to the user with the best channel state which means assign each subchannel to the user who

will transmit with the highest rate on this subchannel.

$$i^* = \arg i \in I \max R_i(t) \tag{16}$$

Let us define for each scheduling algorithm the “decision function” $f_{SCH}(m)$ is the function which the scheduler “SCH” used to decide which subchannel is assigned to which user each scheduling slot. The scheduler “SCH” assigns subchannels to users with the highest value of $f_{SCH}(m)$.

As we consider real time traffic we have to see how the decision function of each scheduler changes with the delay of the HOL packet $w_i(t)$.

For the MLWDF

$$f_{MLWDF}(m) = - \frac{\log(\delta_i)}{D_i^{\max} \bar{R}_i(m)} * w_i(m) * R_i(t) \tag{17}$$

For the CSDS scheduling

$$f_{CSDS}(m) = R_i(m) \tag{18}$$

For the utility based scheduling

$$f_{utility}(m) = \left(\frac{q e^{-q(w_i(m) - D_{\max i})}}{(1 + e^{-q(w_i(m) - D_{\max i})})^2} \right) \min(R_{i,k,n}(m), Q_i(m)/T_s) / \bar{R}_i(m) \tag{19}$$

As can be seen from (18), the channel aware scheduling doesn't depend on $w_i(m)$ at all.

Where as from (19), the decision function of MLWDF change linearly with $(w_i(m))$ and the slope of the line change with δ .

Figure.5 shows the decision function for the utility based scheduling algorithm. Here we see that this decision function does not change with $w_i(m)$ until $w_i(m)$ comes to be near the maximum allowed delay which is assumed here to be 250ms. So our decision function is not like that of channel aware scheduling which does not change with $w_i(m)$. At the same time, utility based scheduling algorithm decision function is not like that of MLWDF which changes linearly with the change in $w_i(m)$.

In the following we will make assessment and comparison between these algorithms but from two different points of view. The first point of view is the network performance evaluated in terms of system-centric quantities namely system capacity, system spectral efficiency and the fairness between users. The second is the network performance evaluated in terms of the degree to which network satisfies the service requirements of users' applications. As we consider rt-tps traffic we take the average delay as indication to the service requirements of users' applications.

5-1 Performance evaluation in terms of system-centric quantities “system capacity and spectral efficiency”:

In this section we study the performance of the scheduling algorithms in terms of the system capacity and the system spectral efficiency. From the system point of view a good scheduler should increase the system capacity and spectral efficiency to ensure good using of system resources.

As shown in figure.6 we note that the CSDS algorithm achieves the highest system capacity .The MLWDF scheduling achieves the lowest system capacity. This is because CSDS scheduling algorithm assigns each subchannel to the user with the best channel state (highest SNR). The MLWDF achieves the minimum total system capacity because when MLWDF scheduling assign subchannels to users it does not depend only on the channel state but it takes into consideration the user requirements.We mean with “user requirements” the required QOS of the user in terms of maximum allowed Head of Line (HOL) packet delay, and the required packet dropping ratio (PDR), where MLWDF have linearly dependency on the HOL packet delay. If we return to figure.6 we see that our utility-based scheduling algorithm have better system capacity than MLWDF scheduling ,while it has lower capacity than channel state dependent scheduling algorithm. This can be explained as follow; while utility based scheduling seems to be like MLWDF in that it assigns subchannels to users taking into consideration the required QOS of the user in terms of maximum allowed HOL packet delay and the required packet dropping ratio. But utility based scheduling treat this in completely different manner which can be seen from the decision function of each scheduler. The utility based scheduler assigns subchannels based on the channel state as long as the average waiting time is far from the maximum allowed waiting delay. When the waiting delay increases and becomes close to the maximum allowed delay the scheduler must serve this user quickly before the packet expires.

In figure 7 we study the system spectral efficiency which is defined as:

$$\text{System spectral efficiency} = \frac{\text{total_system_throughput_of_all_users}}{\text{total_system_BW}} \text{ bps/Hz}$$

(20)

Figure 7 indicates that the CSDS scheduling achieves the highest system spectral efficiency while MLWDF achieves the lowest system spectral efficiency. Our utility based scheduling achieves improvement in the system spectral efficiency than MLWDF scheduling algorithm.

In figure.8 we measure the fairness metric between the users for these scheduling

algorithms. The fairness metric is represented by the standard deviations between users' transmission rates for the case of 45 active users in the system. It is known that the large standard deviations between users transmission rates means less fairness between users.

As indicated in figure.8 the utility based scheduling algorithm achieves better fairness than the CSDS algorithm. While the MLWDF scheduling algorithm achieves the best fairness among the scheduling algorithms, but at the same time this fairness measure change for different channel conditions (we made four different runs with different channel conditions), for some channel conditions it is high and for others it is low. The utility based algorithm results in higher standard deviation but it is can be characterized by almost constant value for different channel conditions.

5-2 Performance evaluation in terms of satisfying user's application requirement:

Here we evaluate the performance of the scheduling algorithms in terms of the degree to which the scheduling algorithms satisfy the user's application requirement.

Figure9 indicates that the CSDS algorithm achieves the highest average waiting delay. This is naturally as this scheduling algorithm doesn't take into consideration any traffic requirements and only depend on the subchannel state. On the other hand, MLWDF achieves the smallest average delay. This can be explained since, f_{MLWDF} increases linearly with any increase in the HOL packet delay so it assign subchannels to users with the highest waiting delay. Our proposed utility based algorithm, have performance better then the channel state dependent scheduling algorithm. This is because; utility based algorithm assigns subchannels to users taking into consideration the user QoS requirements. But it dose not achieve small waiting delay similar to that of MLWDF because its decision function does not change with $w_i(m)$ until $w_i(m)$ is approaching its maximum.

In figure.10 we provide another comparison criterion between our scheduling algorithm and CSDS and MLWDF scheduler. This criterion is considered based on an objective function given by the ratio between the average throughput per user and the average HOL packet delay. Our results show that our utility based scheduler has the highest ratio for any number of active users in the system

6. Conclusions:

In this paper we developed a new scheduling and resource allocation algorithm for DL rt-ps traffic for MIMO based IEEE802.16e. Our scheduling algorithm is based on a new utility function and is designed to maximize the total sum of the utility functions, which reflects the user satisfaction level while satisfying the user traffic requirements. The simulation results show that, under different channel conditions, our algorithm have

better throughput than MLWDF, and have better average delay than channel state dependent algorithm. At the same time our scheduler has the highest ratio of average throughput per user and average HOL packet delay for any number of active users in the system.

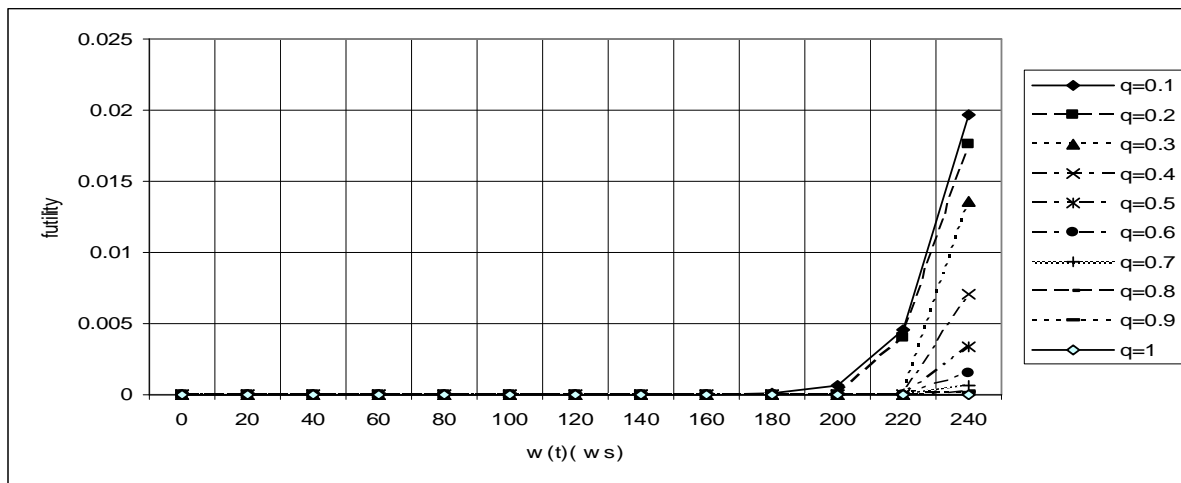

Figure(5): $f_{utility}$ versus $w(t)$

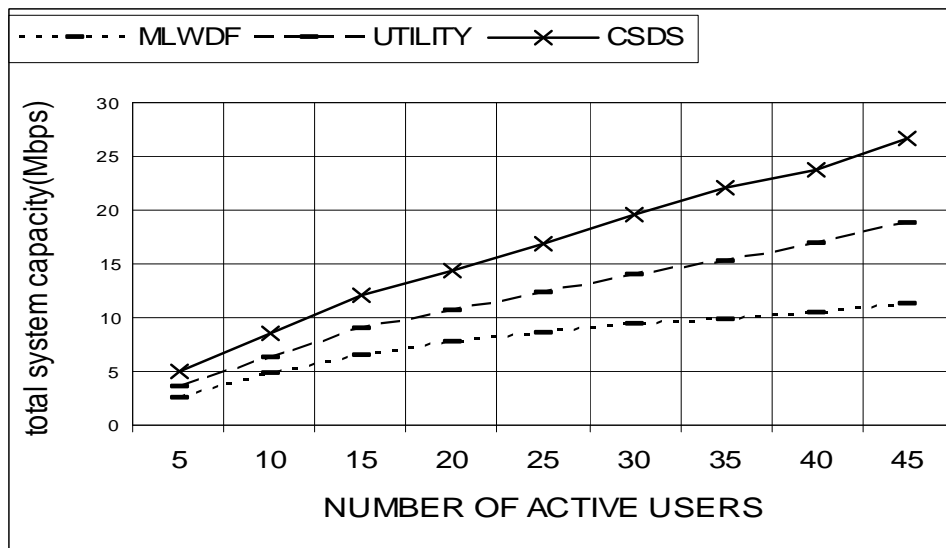

Figure(6): the total system capacity versus numbers of active users in the system

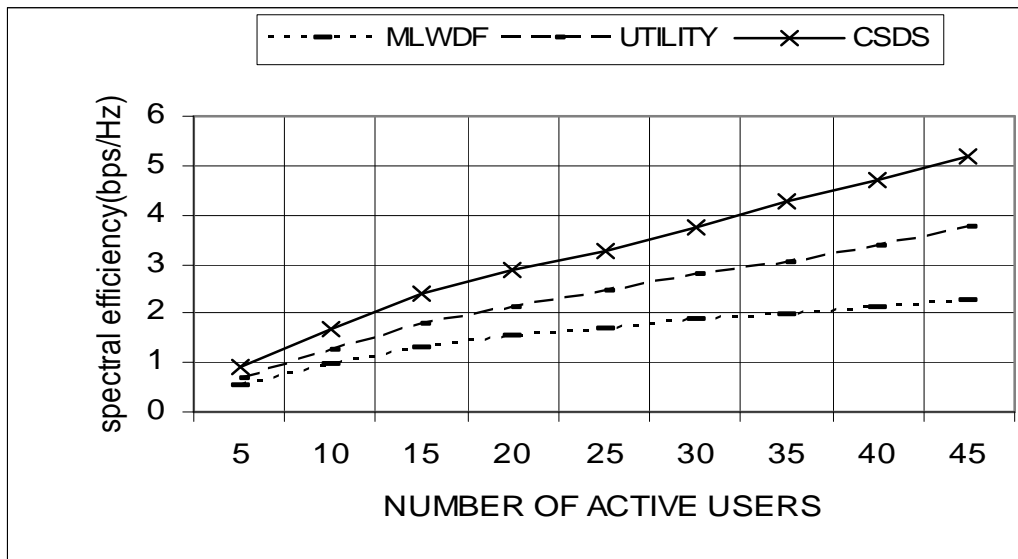

Figure(7): System spectral efficiency versus numbers of active users in the system

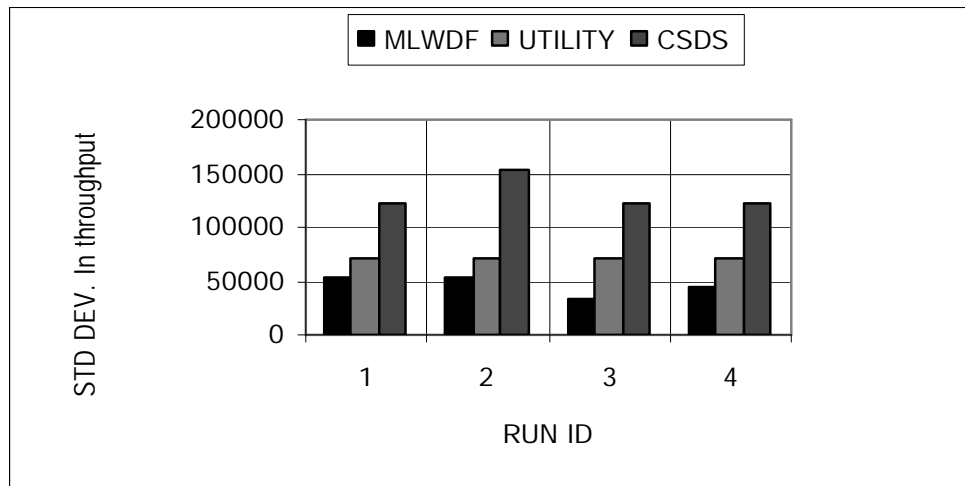

Figure(8): standard deviation in throughput for different channel states
(45 users in the system)

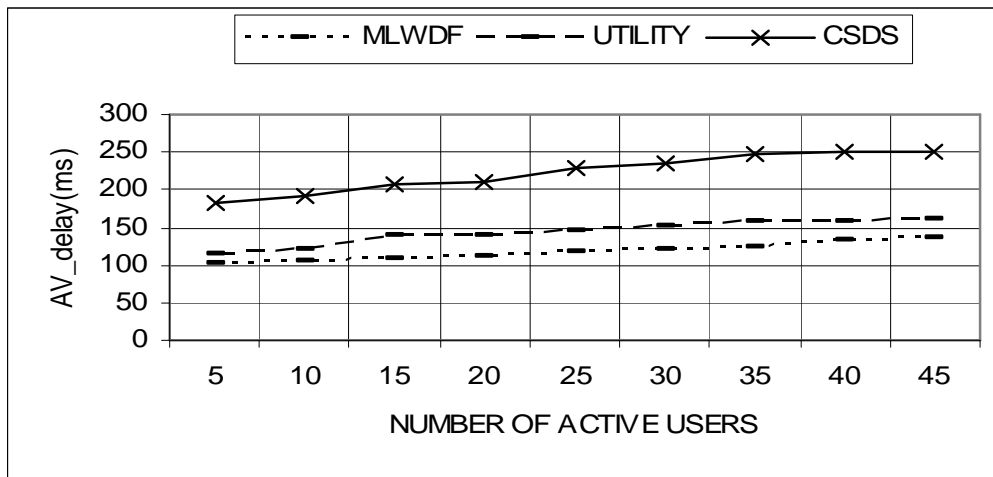

Figure(9):Average HOL packet delay versus number of active users

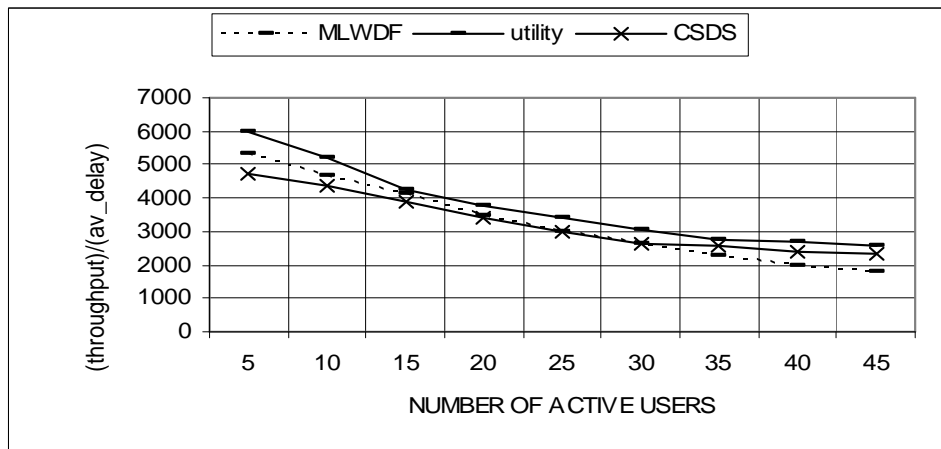

Figure(10):(Average throughput)/(average delay)versus number of active users

References:

[1] Z. Han, Z. Ji, and K.J.Liu, Fair Multiuser Channel Allocation for OFDMA Networks using Nash Bargaining Solutions and Coalitions, IEEE Trans. On Comm.,Vol.53,No.8, pp.1366-1376, Aug. 2005.

- [2] H. Weilan, and Lataief-KB, A Cross Layer Resource Allocation And Scheduling For Multiuser Space-Time Block Coded MIMO/OFDM System, Proc of IEEE-International-Conference-on Comm.,Vol.4, pp.2655-2659, 2005
- [3] E. Telatar, Capacity of Multi-antenna Gaussian Channels, AT&T Bell labs Tech. Memo., Mar. 1995.
- [4] G. J. Foschini and M. J. Gans, On limits of Wireless Communications in a Fading Environment When Using Multiple Antennas, Wireless Personal Communication., vol. 6, no. 3, pp311-335, Mar. 1998.
- [5] S. M. Alamuti, A simple transmit diversity technique for wireless communications, IEEE Journal on Selected Area in Communications, Vol. 16, pp 1451-1458, October. 1998.
- [6] V. Tarokh, H. Jafarkhani, and A. R. Calderbank, Space-time Block Codes from Orthogonal Designs, IEEE Transactions on Information Theory, vol. 45, pp. 1456-1467, July 1999.
- [7] G. J. Foschini, G. D. Golden, P. W. Wolniansky, and R. A. Valenzuela, Simplified Processing for Wireless Communication at High Spectral Efficiency, IEEE Journal on Selected Areas in Communications, vol. 17, pp1841-1853, 1999.
- [8] G. J. Foschini, Layered Space-Time Architecture for Wireless Communication in a Fading Environment When Using Multielement Antennas, Bell Labs Tech. J.,Vol.1,ISSUE 2, pp. 41-59, Autumn 1996.
- [9] Mobile WIMAX-part I: A technical overview and performance evaluation, WIMAX forum, Aug. 2006.
- [10] IEEE P802.16e/D12, Oct. 2005
- [11] I. Koutso and L. Tassisuals, Cross-Layer Adaptive Techniques for Throughput Enhancement in Wireless OFDM-Based Networks, IEEE/ACM Transactions on Networking, Vol. 14, No. 5, pp 1056-1066,Oct. 2006.
- [12] V. N. Lau , Y. Kwong, and Ricky Kwok, Channel-Adaptive Technologies and Cross-Layer Designs for Wireless Systems with Multiple Antennas: Theory and Applications, WILEY-INTERSCIENCE, 2006.

- [13] D. Kim, B. Han, and Chung-Kang, Packet Scheduling Algorithm Considering a Minimum Bit Rate for Non-real time traffic in OFDM/FDD-Based Mobile Internet Access System, ETRI Journal, vol.26, pp.48-52 Feb. 2004.
- [14] Scott Shenker , Fundamental Design Issues for Future Internet, IEEE Journal On Selected Areas in Comm., Vol.13, No.7, pp1176-1185, Sept. 1995.
- [15] G. Song and Y. Li, Utility Based Joint Physical-MAC Layer Optimization in OFDM, Proc of IEEE Globecom, Vol.1, pp671-675, Nov 2002.
- [16] G. Song and Y. Li, Utility Based Resource Allocation and Scheduling in OFDM-Based Wireless Broadband Networks, IEEE Comm. Magazine, Vol.43, No.12, pp 127-135, Dec. 2005.
- [17] S. Ryu, B. Ryu, H. Seo, and M. Shin, Urgency and Efficiency Based Packet Scheduling Algorithm for OFDMA Wireless Systems, Proc of IEEE International Conference on Communications, Vol. 4, pp 2779-2785, May 2005.
- [18] L. Lei and N. Zhisheng, An integrated subchannel scheduling algorithm for Adaptive Modulation and Coding MIMO-OFDM wireless systems, in the proceeding of 10th Asia-Pacific-conference-on communication , v1 p90-94, 2004
- [19] L. Lei and N. Zhisheng, A multi-dimensional radio resource scheduling scheme for MIMO-OFDM systems with channel dependent parallel weighted fair queueing (CDPWFQ), in the proceeding of 10th Asia-Pacific-conference-on communication, v4, p 2367-2371, 2004.
- [20] H. Bloeski, D. Gesbert, and A. Swami, On the capacity of OFDM-Based Spatial Multiplexing Systems, IEEE Trans. on Comm., Vol.50, No.2, pp 225-234, Feb. 2002.
- [21] G. Song and Y. Li, Cross-Layer Optimization for OFDM Wireless Networks-part I: Theoretical Framework, IEEE Trans. on Wireless Comm., Vol. 4, No. 2, pp. 614-624, Mar. 2005

Nomenclatures:

K ...	Number of subcarriers
I ...	Number of active users in the system
η ...	the symbol number from which data in the DL subframe are transmitted
L ...	Number of significant scattered clusters
G_k ...	Receiver weight matrix
$w_i(m)$...	HOL packet waiting delay for user i at frame m
D_i^{\max} ...	Maximum allowed delay for user i
q_i ...	Quantization constant for user i
$\beta_{k,n,i}$...	Indicator if subchannel k on antenna n is assigned to user i
$\bar{R}_i(m)$...	Average rate of user i at frame m
$U_i(w_i(m))$...	Utility function of user i
$f_{SCH}(m)$...	Decision function of scheduler 'SCH'