

PAPER • OPEN ACCESS

A new mathematical model to evaluate the effect of load inclination on aircraft shelter's foundations

To cite this article: M Elhanash *et al* 2023 *J. Phys.: Conf. Ser.* **2616** 012050

View the [article online](#) for updates and enhancements.

You may also like

- [A fast automatic extraction method for rock mass discontinuity orientation using fast k-means++ and fast silhouette based on 3D point cloud](#)
Wei Wu, Keshen Zhang and Hehua Zhu
- [Weakly and semi-supervised learning for sound event detection using image pretrained convolutional recurrent neural network, weighted pooling and mean teacher method](#)
Xichang Cai, Dongchi Yu, Duxin Liu et al.
- [A Zero-Shot Learning Method Using Artificial Neural Network for Drift Calibration of Gas Sensor Array](#)
Yu-Chieh Cheng, Ting-I Chou, Jye-Luen Lee et al.

PRIME
PACIFIC RIM MEETING
ON ELECTROCHEMICAL
AND SOLID STATE SCIENCE

HONOLULU, HI
Oct 6-11, 2024

Abstract submission deadline:
April 12, 2024

Learn more and submit!

Joint Meeting of
The Electrochemical Society
•
The Electrochemical Society of Japan
•
Korea Electrochemical Society

A new mathematical model to evaluate the effect of load inclination on aircraft shelter's foundations

M Elhanash¹, A K Elsherif¹, H N Zaky¹ and N M Nagy²

¹ Mathematics Department, Military Technical College, Cairo, Egypt.

² Civil engineering Department, Military Technical College, Cairo, Egypt.

E-mail: elhanash@mtc.edu.eg

Abstract. Aircraft shelter is a structure or a reinforced hanger that has many uses in military aspects. It is used to protect military aircraft from different dangers such as enemy chemical attacks. Also, it provides housing, permitting aircraft maintenance and it can be storage for different weapons. therefore, optimum design of aircraft shelter is of a great importance. It may take several shapes to be suitable for its usage. It can be made from concrete, steel or composite materials. The foundations of an airplane shelter must be designed as best as possible. Design objectives are greatly impacted by the contact pressure between the earth and the foundation surface. Classical method in design assumes maximum uniform linear distribution of pressure under contact surface of footing. So, considering real contact pressure has a great interest for many authors. In this article, a new analytical method is proposed to study the effect of moments and load inclination on the design of rectangular isolated footing. The model proposed takes into consideration the real soil pressure. A parametric study was conducted and data obtained from classical model were larger than those from proposed model. Seven Rectangular isolated footings were designed using traditional method and proposed method. The proposed method is more economic since it provides less concrete dimensions. Results obtained from the new model were compared with FEM and achieved reasonable agreement.

Keywords: Inclination load-Isolated footing-Real pressure-Contact surface

1. Introduction

Foundation is a basic structure element that transmits structure loads and moments safely to the soil. Foundations are classified into several types depends on depth of footing, geometry and their function. According to depth there are shallow foundations and deep foundations which differ in geometry (square-rectangular-circular-...etc.). There are different types of shallow foundations according to functionality (isolated-combined-Raft and strip footing). Contact pressure between soil and foundation has a great effect on design purposes. Distribution of pressure under foundation surface depends on various factors such as (type of footing-relative rigidity between soil and foundation-depth of foundation surface) [1].



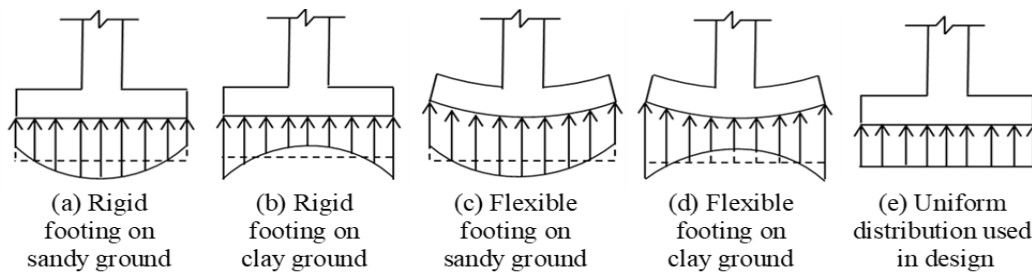

Figure 1. different contact pressure distribution for different types of soil and footings.

Classical method in design assumes maximum uniform linear pressure at all points of contact surface [1]. The traditional method has discussed the most common shapes of shallow RC footings both square and rectangular [2]. Limited studies were made by authors to study design of irregular shapes of footings (trapezoidal-triangular) [3]. AL-Ansari produced a simplified analytical model to study the design of irregular shapes of RC footings [4]. Leonidas discussed the problem of determining pressure and settlement of rigid foundations resting on an elastic layered soil [5]. Gunerathne discussed the analysis of uniformly-loaded circular tank foundation resting on soil [6,7]. Several studies were performed to analyze settlement of thick and thin elastic plates[8–12]. Several numerical studies were carried to analyze shallow foundations on reinforced soil[13–15]. Mathematical modeling is of a great importance to describe the real problem in terms of equations[16–18]. Classical method in design does not take into consideration the real soil pressure. Considering maximum distribution of pressure under contact surface results in producing larger dimensions and area of steel which lead to more cost. So, considering real pressure at all points of contact was adopted by many authors. Rojas introduced new mathematical models for design of different shallow foundations. [19]

In this article, an analytical method is proposed to discuss the effect of moments and load inclination on the design of rectangular isolated footing. A general formula of critical sections of moments, unidirectional shear and bidirectional shear force is obtained using volume of pressure. A parametric study was performed for four different inclined angles. Data obtained from classical method were larger from those obtained from the proposed model. Results obtained from the new model compared with FEM were of a great acceptance. The new analytical model is closer to reality and more economic than the traditional model since it takes into consideration the variation of pressure at every point of contact surface.

2. Methodology

2.1. Problem definition

The analysis considers a RC rectangular footing with width “B”, length “L” and thickness “t” subjected to two orthogonal moments in both directions (around x-axis and y-axis) and inclined load that makes angle θ with the vertical line (see **Figure 2**).

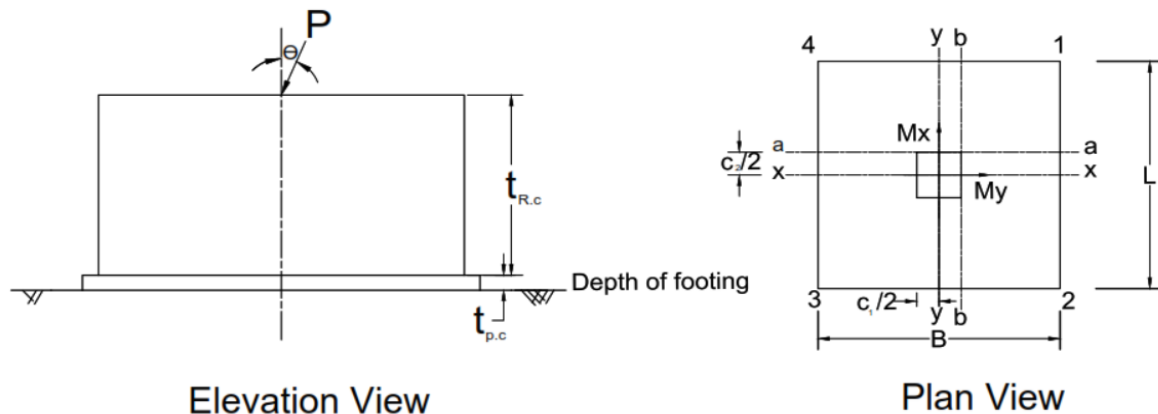

Figure 2. Rectangular isolated footing subjected to inclined load and two orthogonal moments.

For a rectangular isolated footing subjected to inclined load and two orthogonal moments (moment around x-axis and moment around y-axis), stress can be calculated at any point of contact surface from the general equation [20]:

$$\sigma(x,y) = \frac{P \cos \theta}{A} \pm \frac{M_x}{I_x} y \pm \frac{(M_y + P \sin \theta * t)}{I_y} x \quad (1)$$

where $\sigma(x,y)$ is the stress at any point of contact surface, A is the area of the rectangular footing, M_x is the moment around x-axis, M_y is the moment around y-axis, I_x is the moment of inertia around x-axis, I_y is the moment of inertia around y-axis, θ is the inclination angle of the load with the vertical line, P is the load applied at the center of the footing, t is the summation of thickness of RC footing and the plain concrete thickness. x and y are the coordinates of any point on the surface of contact between soil and foundation. Stresses at each corner can be found using equation (1)

$$\sigma_1 = \frac{P \cos \theta}{A} + \frac{M_x}{I_x} y + \frac{(M_y + P \sin \theta * t)}{I_y} x \quad (2)$$

$$\sigma_2 = \frac{P \cos \theta}{A} - \frac{M_x}{I_x} y + \frac{(M_y + P \sin \theta * t)}{I_y} x \quad (3)$$

$$\sigma_3 = \frac{P \cos \theta}{A} - \frac{M_x}{I_x} y - \frac{(M_y + P \sin \theta * t)}{I_y} x \quad (4)$$

$$\sigma_4 = \frac{P \cos \theta}{A} + \frac{M_x}{I_x} y - \frac{(M_y + P \sin \theta * t)}{I_y} x \quad (5)$$

where $\sigma_{\min} \geq 0$ (compression only) and σ_{\max} does not exceed allowable bearing capacity of soil. According to equation (1) stress varies from point to another. Methods of calculus were used to evaluate real pressure. Using double integration technique to calculate volume of pressure to present formula for critical sections of moments, unidirectional shear and punching shear.

2.2. Critical sections for moments

Critical sections of moments for rectangular isolated footing occurs at column face as shown in **Figure 2**. To evaluate the moment around b-b axis; resultant force of pressure from the column face until the edge of the footing is being calculated then multiply the resultant force by the distance to the column face section [20-21]:

$$\begin{aligned} F_1 &= \int_{-l}^2 \int_{\frac{c1}{2}}^{\frac{b}{2}} \frac{P \cos \theta}{A} \pm \frac{M_x}{I_x} y \pm \frac{(M_y + P \sin \theta * t)}{I_y} x \, dx \, dy \\ F_1 &= \frac{P \cos \theta (b - c1)}{2b} + \frac{3(M_y + P \sin \theta * t)(b^2 - c1^2)}{2b^3} \\ X_c &= \frac{\int \int_D x \sigma(x,y) \, dA}{\int \int_D \sigma(x,y) \, dA} = \frac{P \cos \theta * b^2 (b^2 - c1^2) + 4(M_y + P \sin \theta * t)(b^3 - c1^3)}{4P \cos \theta * b^2 (b - c1) + 12(M_y + P \sin \theta * t)(b^2 - c1^2)} \\ M_{b-b} &= F_1 * (X_c - \frac{c1}{2}) \end{aligned} \quad (6)$$

Similarly moment around a-a axis can be obtained using the same procedures:

$$F_2 = \frac{P \cos \theta (l - c_2)}{2l} + \frac{3Mx(l^2 - c_2^2)}{2l^3}$$

$$Y_c = \frac{P \cos \theta * l^2 (l^2 - c_2^2) + 4Mx(l^3 - c_2^3)}{4P \cos \theta * l^2 (l - c_2) + 12Mx(l^2 - c_2^2)}$$

$$M_{a-a} = F_2 * (yc - \frac{c_2}{2}) \tag{7}$$

2.3. Critical sections of shear

The critical section for unidirectional shear occurs at distance “d” from column face in both directions while punching shear force occurs at distance “d/2” see **Figure 3**.

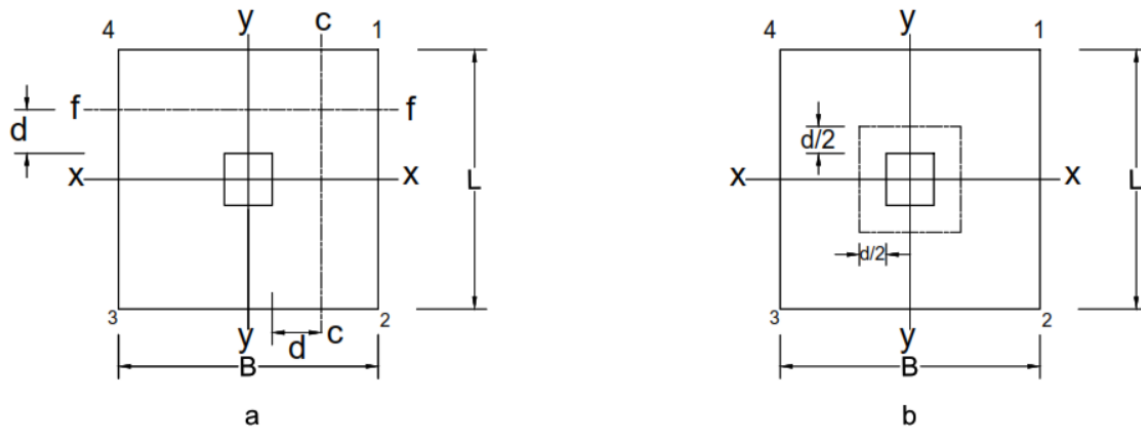

Figure 3. figure “a” shows the critical sections of unidirectional shear (section f-f & section c-c). Figure “b” shows critical section of punching shear force at distance d/2 from column face.

Formula of unidirectional shear for section (f-f) and section (c-c) can be derived by integrating contact pressure.

$$V_{f-f} = \int_{\frac{c_2}{2} + d}^{\frac{l}{2}} \int_{-\frac{b}{2}}^{\frac{b}{2}} \sigma(x,y) dA$$

$$V_{f-f} = \int_{\frac{c_2}{2} + d}^{\frac{l}{2}} \int_{-\frac{b}{2}}^{\frac{b}{2}} \frac{P \cos \theta}{bl} \pm \frac{Mx}{I_x} y \pm \frac{(My + P \sin \theta * t)}{I_y} x dx dy$$

$$V_{f-f} = \frac{P \cos \theta (l - c_2 - 2d)}{2l} + \frac{3Mx(l^2 - c_2^2 - 4c_2d - 4d^2)}{2l^3} \tag{8}$$

Similarly

$$V_{c-c} = \int_{\frac{c_1}{2} + d}^{\frac{b}{2}} \int_{-\frac{l}{2}}^{\frac{l}{2}} \frac{P \cos \theta}{bl} \pm \frac{Mx}{I_x} y \pm \frac{(My + P \sin \theta * t)}{I_y} x dy dx$$

$$V_{c-c} = \frac{P \cos \theta (\frac{b}{2} - \frac{c_1}{2} - d)}{b} + \frac{6(My + P \sin \theta * t) (\frac{b^2}{4} - (\frac{c_1}{2} + d)^2)}{b^3} \tag{9}$$

And for punching shear force (Q)

$$Q = \int_{-\frac{l}{2}}^{\frac{l}{2}} \int_{-\frac{b}{2}}^{\frac{b}{2}} \frac{P \cos \theta}{A} \pm \frac{Mx}{I_x} y \pm \frac{(My + P \sin \theta * t)}{I_y} x dx dy - \int_{-\frac{c_2}{2}}^{\frac{c_2}{2}} \int_{-\frac{c_1}{2}}^{\frac{c_1}{2}} \frac{P \cos \theta}{A} \pm \frac{Mx}{I_x} y \pm \frac{(My + P \sin \theta * t)}{I_y} x dx dy$$

$$Q = P \cos \theta - \frac{P \cos \theta (c_1 + d)(c_2 + d)}{bl} \tag{10}$$

Equations. (1-10) can be programmed using any software of mathematics (MATLAB - Mathematica) for quick calculations of stress, moment and shear force.

3. Numerical study and discussion

A parametric study was performed to study the accuracy and validation of the analytical method using ACI (American concrete institute) [22]. Results from the new model are compared with those from FEM (safe software). Also, comparisons were made with those from literature Al-Ansari [4]. Case study, a square isolated RC footing subjected to two orthogonal moments (moment around x-axis and moment around y-axis) and supports a column located at its center with four different inclination angles. Design parameters:

Table 1. Design parameters.

Parameter	value	unit
P_D	50	ton
P_l	30	ton
$M_{l,x}$	6	ton.m
$M_{l,y}$	4	ton.m
D_f	1.5	m
q_a	22	t/ m ²
γ_c	2.5	kg/cm ³
γ_s	1.5	kg/cm ³
F_{cu}	250	kg/cm ²
Theta	0, 5, 15, 18	degree

Where

P_D working dead load

P_l working live load

$M_{l,x}$ moment around x-axis

$M_{l,y}$ moment around y-axis

q_a allowable bearing capacity of soil

F_{cu} compressive strength of concrete

D_fdepth of footing

γ_c ...self weight of concrete

γ_s ...self weight of soil

3.1. Comparison with traditional method

Design of the RC rectangular isolated footing had been discussed using the classical technique in design that considers the maximum contact pressure at all points of contact and with the new analytical method. Figures below show differences between the two models.

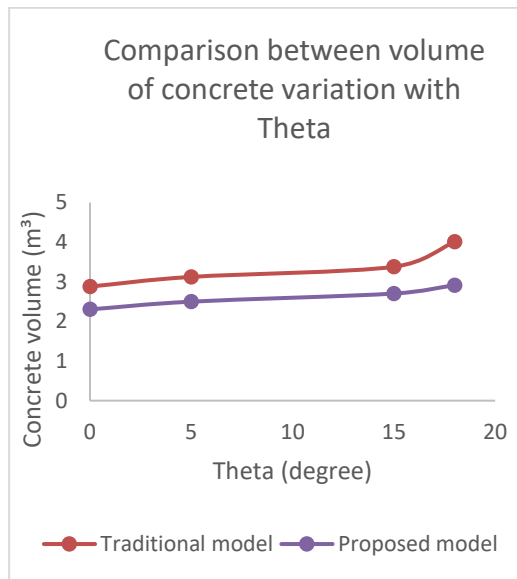

Figure 4. volume of concrete comparison at different inclination load angle.

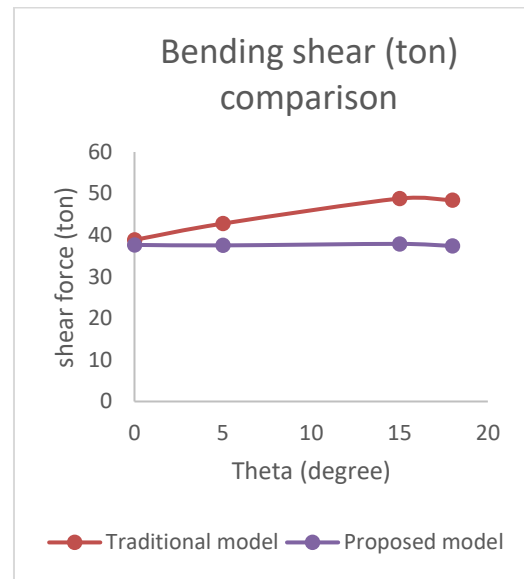

Figure 5. Unidirectional shear comparison of the two models.

Figure 4. shows that the concrete volume of the isolated footing increases with the increase of load inclination angle. That happened because of increasing inclination load results in increasing stress under footing contact surface due to increase in moment around y-axis. Furthermore, It decreases the term $(\frac{P \cos \theta}{A})$. It is obvious that at all different inclination load angles, volume of concrete in case of proposed model is less than in case of traditional model. Figure 5. describes the relation between shear force by flexure or unidirectional shear force in (ton) and the different inclination load angles. The graph show that in both models the shear force increases until certain limit (theta=15 degree) then decreases after that. The explanation for this change is due to increasing inclination angle of load reduces the vertical load component. Values of shear force were less in case of proposed model at all different inclination angles. This difference is noticeable at bigger values of theta.

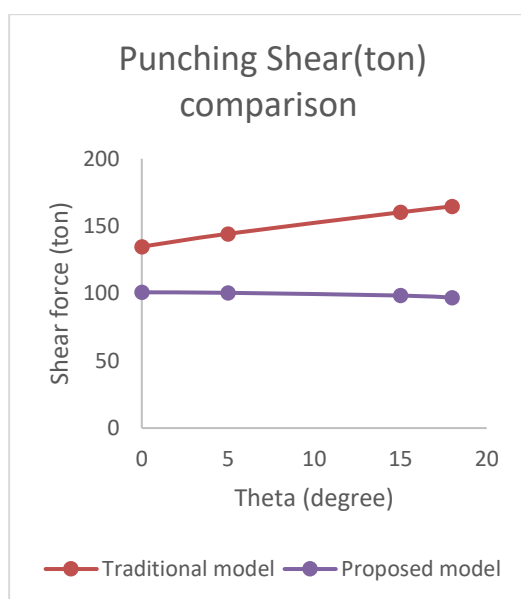

Figure 6. Bidirectional shear comparison of the two models.

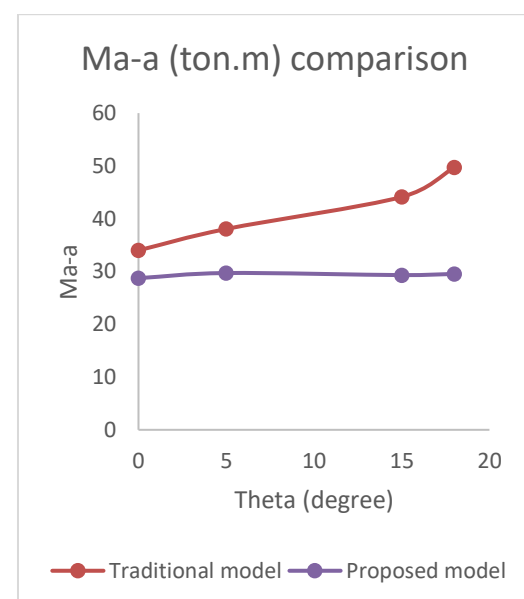

Figure 7. Moment around section (a-a) comparison.

Figure 6. describes the relation between punching shear force or bidirectional shear (ton) and different inclination angles of load. It is remarkable that there is a clear difference between classical model and the proposed one. Larger values in punching shear force in classical model results in increase in depth of the footing. So, the new model is more economic than the traditional one. Figure 7. illustrate the relation between moment around section (a-a) and various inclination load angles. The graph shows there is a rapid increase in moment with variation of theta. On the other hand, the proposed model has a smaller values at the same corresponding theta. Larger values of moment cause more area of steel in design.

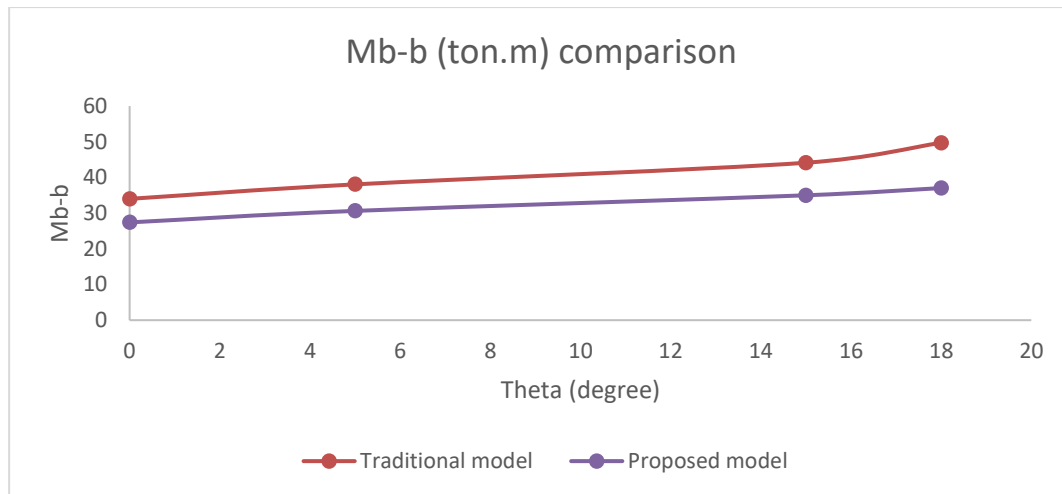

Figure 8. Moment around section (b-b) comparison.

Figure 8. analyzes the results of moment around section (b-b) and theta variation. For the two models moment increases with the increase of inclination load angle. Proposed model provides less values of moment which minimize area steel in that direction. Results showed that in all cases outcomes of the classical model is larger than those of the proposed one.

3.2. Comparison with FEM

To check the accuracy and validation of the new analytical method; four different models were defined using safe software. Author used the same dimensions obtained from proposed model and compared values of critical sections of moments. The safe model was defined by the following characteristics:

Table 2. Design parameters of safe model.

Col.dimensions	subgrade modulus	L=B	Thickness	γ_c
30*30 cm	$2 \cdot 10^4$ KN/m ³	2.4 m	40 cm	2.5 kg/cm ³
30*30 cm	$2 \cdot 10^4$ KN/m ³	2.5 m	40 cm	2.5 kg/cm ³
30*30 cm	$2 \cdot 10^4$ KN/m ³	2.6 m	40 cm	2.5 kg/cm ³
30*30 cm	$2 \cdot 10^4$ KN/m ³	2.7m	40 cm	2.5 kg/cm ³

The inclined load was presented by two components “ $P \cos\theta$ ” in vertical direction and “ $P \sin\theta \cdot t$ ” represented by M_y -y , Column dimension= 30*30 cm , thickness of footing= 40cm , $\gamma_c = 2.5$ kg/cm³. Results from analytical model compared with those from FEM and were of a great acceptance. slight difference in results are due to configuration of soil stiffness in safe model.

Table 3. Ma-a comparison (ton.m).

Theta	Proposed model	FEM
0	28.73	28.44
5	29.70	29.66
15	29.31	30.20
18	29.53	31.01

Table 4. Mb-b comparison (ton.m).

Theta	Proposed model	FEM
0	27.40	27.14
5	30.62	30.04
15	34.99	35.67
18	37.02	37.90

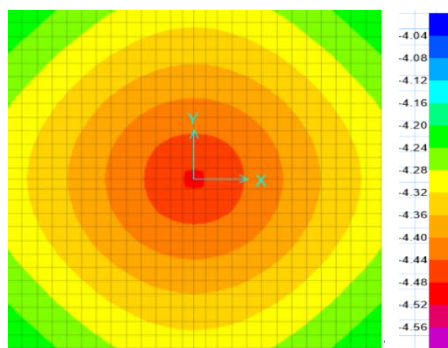

Footing theta=0
(a)

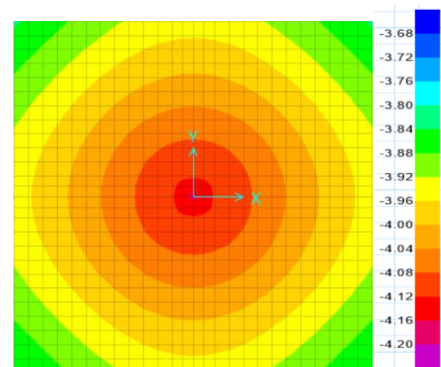

Footing theta=5
(b)

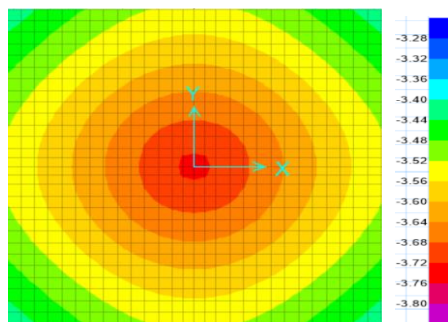

Footing theta=15
(c)

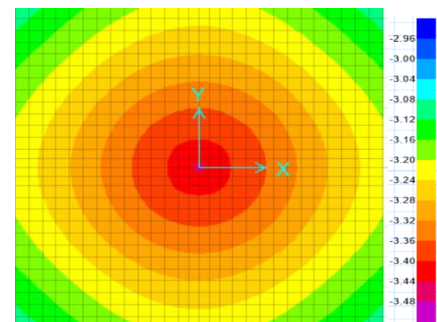

Footing theta=18
(d)

Figure 9. Settlement contours for different inclination load.

3.3. Comparison with previous studies

In case of $\theta=0$, Results are compared with Al-Ansari [4] who used the classical technique in design. Seven different square footings with different loads are compared.

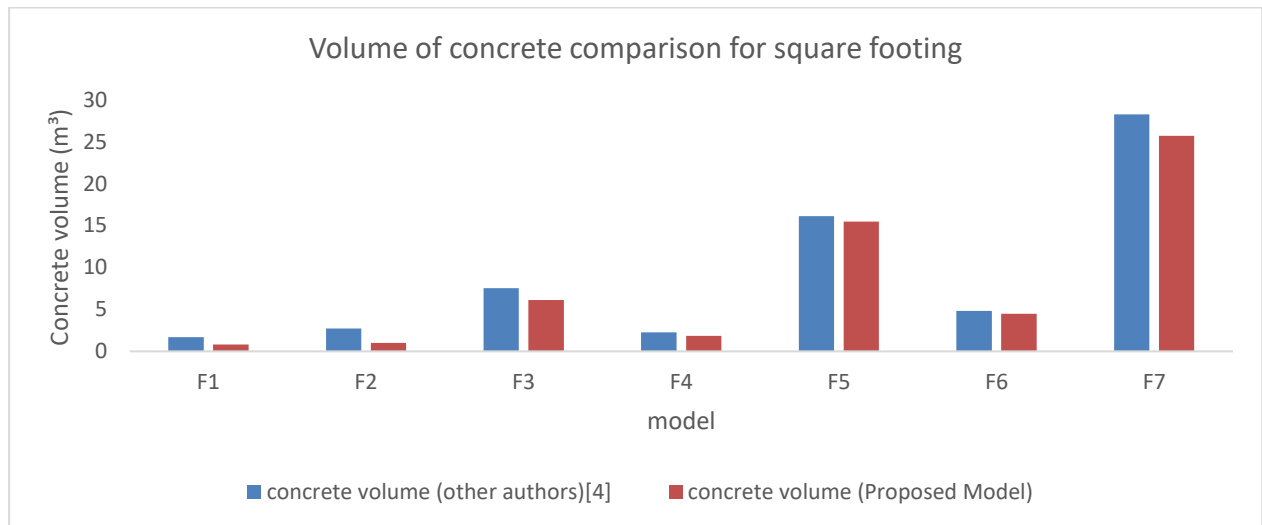

Figure 10. shows that the proposed model provides less dimensions of square footing in all cases of design.

4. Results and Conclusion

In this article, an analytical method has been proposed for optimum design of rectangular isolated footing subjected to inclined load and two orthogonal moments (moment around x-axis and moment around y-axis). The proposed model is close to reality since it considers the variation of stress at every point. Formulas for critical moment, unidirectional shear and punching shear have been derived using methods of calculus. Four different load inclination angles were considered in design and results were less than those from classical method in all cases. Results from the new analytical method compared with those from literature were more economical. Volume of concrete was reduced by 25% in case of using the proposed model in design. Also, to validate the proposed model results were compared with FEM and were of a great agreement. In large projects, the new model is more economic since it provides less dimensions of foundation and less area of steel.

References

- [1] Bowles J E 2001 Foundation Analysis and Design ed McGraw-Hill (New York Scientific Research)
- [2] Braja M. Das N S 2018 Principles of Foundation Engineering (United states of America: Cengage)
- [3] Gajan S, Raychowdhury P, Hutchinson T C, Kutter B L and Stewart J P 2010 Application and validation of practical tools for nonlinear soil-foundation interaction analysis *Earthquake Spectra* **26** 111–29
- [4] Al-Ansari M S and Afzal M S 2021 Structural analysis and design of irregular shaped footings subjected to eccentric loading *Engineering Reports* **3** 1–17
- [5] Stavridis L T 2009 Rigid foundations resting on an elastic layered soil *Geotechnical and Geological Engineering* **27** 407–17
- [6] Gunerathne S, Seo H, Lawson W D and Jayawickrama P W 2018 Analysis of edge-to-center settlement ratio for circular storage tank foundation on elastic soil *Comput. Geotech.* **102** 136–47
- [7] Gunerathne S, Seo H, Lawson W D and Jayawickrama P W 2019 Variational approach for settlement analysis of circular plate on multilayered soil *Appl. Math Model* **70** 152–70
- [8] Nguyen T H 2019 Analysis of Rectangular Plates on Resting Winkler and Two-Parameter Elastic Foundation Models by Finite Difference Method *Engineering, Tech. & Appl. Science Research* **9** 4490–4
- [9] Cen S and Shang Y 2015 Developments of Mindlin-Reissner plate elements *Math Probl. Eng.* **2015**

- [10] Wheel M 1997 A finite volume method for analysing the bending deformation of thick and thin plates *Methods Appl. Mech. Engrg* **147** 199–208
- [11] Han J-B and Liew K M 1997 NUMERICAL DIFFERENTIAL QUADRATURE METHOD FOR REISSNER/MINDLIN PLATES ON TWO-PARAMETER FOUNDATIONS *Int. J. Mech. Sci* **39** 977–89
- [12] Ureña F, Saleté E, Benito J J and Gavete L 2012 Solving third- and fourth-order partial differential equations using GFDM: Application to solve problems of plates *Int. J. of Computer Mathematics* **89** pp 366–76
- [13] El-Shesheny A, Nagy N, Belal A and Badawy A 2014 Finite Element Analysis of Square Footing Resting on Geosynthetic Reinforced Soil *The 10th Int. Conf. on Civil and Architecture Engineering* (Military Technical College, ,Egypt) pp 1–11
- [14] Nagy N, Boot J C, Mohamed M H A and Horoshenkov K v. 2006 Numerical investigation into the interaction between buried structures and surface footings subject to impact loads *Proceedings of the 5th Int. Conf. on Engineering Computational Technology*
- [15] Belal A, Nagy N and Elshesheny A 2015 Numerical Evaluation of Bearing Capacity of Square Footing on Geosynthetic Reinforced Sand *Proceedings of the Int. Conf. on Civil, Structural and Transportation Engineering* **143** pp 1–9
- [16] Nasry H, Xu W, Gong J W and Chen H Y 2013 Teleoperation Transparency Using Model Predictive Control *Applied Mechanics and Materials* **446–447** 1151–5
- [17] Mohamed G Abd Elfatah, Hany Nasry Zaky and M Gharib 2019 Mobile robot position estimation using Euler-Maruyama algorithm System *IOP Conf Ser Mater Sci Eng* **610** 012074
- [18] Nasry H 2019 Coordinate Transformation In Unmanned Systems Using Clifford Algebra *Proceedings of the 5th Int. Conf. on Mechatronics and Robotics Engineering* pp 167–70
- [19] Luévanos-Rojas A, López-Chavarría S and Medina-Elizondo M 2018 A new model for T-shaped combined footings part I: Optimal dimensioning *Geomechanics and Engineering* **14** 51–60
- [20] Rojas A L, Herrera J G F, Vallejo R A A and Alvarez M A C 2013 Design of isolated footings of rectangular form using a new model *Int. J. of Innovative Computing, Information and Control* **9** 4001–21
- [21] Rojas A L, Chavarría S L and Medina Elizondo M 2017 Information and Control ICIC International 2017 ISSN *Int. J. of Innovative Computing* **13** 1149–68
- [22] Standard A A ACI 318-11 Building Code Requirements for Structural Concrete (ACI 318-11)