

**Military Technical College  
Kobry El-Kobbah,  
Cairo, Egypt**



**14<sup>th</sup> International Conference on  
Applied Mechanics and  
Mechanical Engineering.**

## **Experimental analysis and performance characteristics of air brake load sensing relay valve**

*By*

S. Abu alyazeed Albatlan\*

### **Abstract:**

The brake system is the primary system in an automobile which ensures its safety on the road. The ideal brake system should operate with the least effort from the driver and should stop the vehicle within the minimum possible distance without losing controllability. This paper deals with the air brake system relay valve experimental performance. The work focuses on different parameters which would affect valve characteristics. Experimental investigation of the valve characteristics under these parameters is performed and analyzed.

### **Keywords:**

Air brake, load sensing relay valve, performance, characteristics and parameters

---

\* Higher Technological Institute, 6<sup>th</sup> of October Branch

## 1. Introduction:

A brake system must ensure the safe control of a vehicle during its normal operation and must bring the vehicle to a smooth stop within the shortest possible distance under emergency conditions [1, 2]. The air brake system currently used in commercial vehicles can be broadly divided into a pneumatic subsystem and a mechanical subsystem. One of the main components in the pneumatic subsystem is the relay valve which operates the brakes on the rear axles of a tractor and the axles of a trailer. A relay valve has different modes of operation and the pressure response of the relay valve can be naturally described as the response of a hybrid system [3].

An air brake system for truck and trailer combinations comprises a vehicle load sensing valve to control brake pressure of the vehicle axles [4]. A vehicle load responsive brake control device for adjusting the braking force according to the varying load of the vehicle in each braking range; the purpose of the brake control device is to adjust the braking forces in accordance with the static and dynamic shifting of the axle loads [5]. For vehicles without electronic control of brake pressure, there is need to vary the control pressure for different load conditions. This is done in order to avoid the instability that would occur if wheels lock (start skidding) in an unsuitable order.

This device is called a load sensing valve [6]. In [7] new generations of mechanical and pneumatic load sensing valves are developed with an integrated relay valve and connection to ABS to meet the requirements for modern commercial vehicles. Natarajan et al. [8] showed complete mathematical model governing the response of the relay valve in an air brake system. The development of an electropneumatic brake which would decrease the response time of the air brake system thereby providing a reduced stopping distance can be found in [9]. In [10] developed a new modeling and simulation methodology for a pneumatic brake system with ABS widely used in commercial vehicle. The construction and operation of load sensing relay valve which is described in [11] and illustrated Fig. (1).

The present paper deals with experimental investigation of performance characteristics of the load sensing relay valve at different operating conditions. A test rig is designed and built for the study purpose, and the analysis of test results is performed.

- 1- Inlet port from treadle
- 2- Primary piston valve
- 3- Inlet from treadle valve
- 4- Atmospheric control valve
- 5- Regulating rod
- 6- Chamber (B)
- 7- Inlet port from reservoir
- 8- Outlet to brake wheel chamber
- 9- Load sensing cam lever
- 10- Load sensing cam
- 11- Upper valve body
- 12- Lower valve body
- 13- Relay piston
- 14- Variable area diaphragm
- 15- Variable area diaphragm disc
- 16- Coil spring
- 17- Chamber (C)
- 18- Inlet valve seat
- 19- Inlet from reservoir

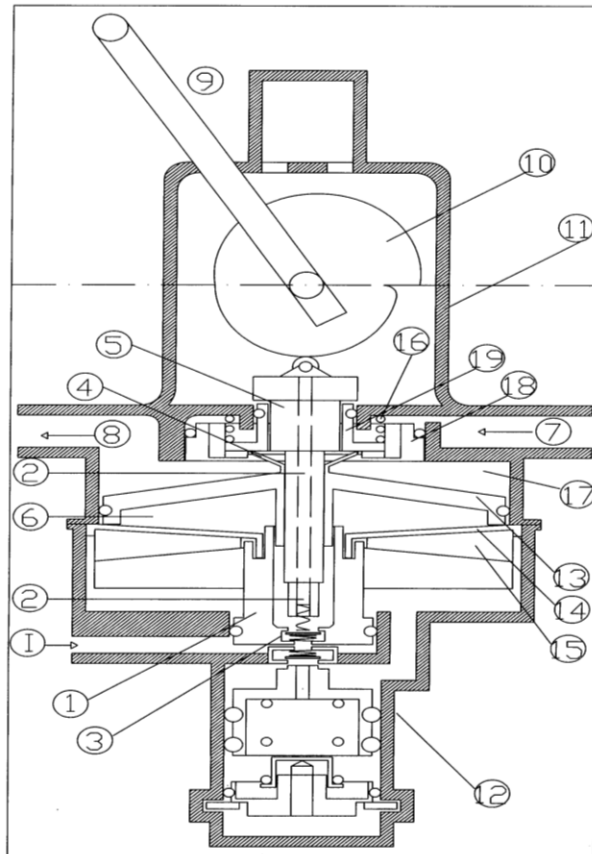

**Figure (1):** Load sensing relay valve main parts [11].

## 2. Experimental Work:

The objective of the experimental work is to test the load sensing relay valve under different operation conditions, and to measure the behavior of brake pressure line. The experimental data were used to evaluate their performance characteristics.

Figure (2) shows a general layout of the test rig, which can be divided, into three main groups: test rig main components, the measuring instruments and data acquisition systems [DAQ]. The details of each group is given below.

### 2.1 Test Rig Main Components

The test rig is designed and built to simulate the vehicle air brake system; the rig uses actual air brake system units and components. It allows testing different types of pressure regulator valves. The air brake system includes an air compressor (1) coupled with electric motor (2), an air tank (3), brake foot valve (treadle valve) (4), load sensing relay valve (5), rear brake chamber (6), rear axle wheel and hoses (7) which connect different components, as shown in Fig (3). Air compressor actuating mechanism showed in Fig. (3) consists of electric motor and V- belt connecting air compressor with motor pulley. To have a wide range of rear axle load, the load sensing lever indexing plate (8) is provided with holes which are corresponding to deflections due to different loads on the rear axle.

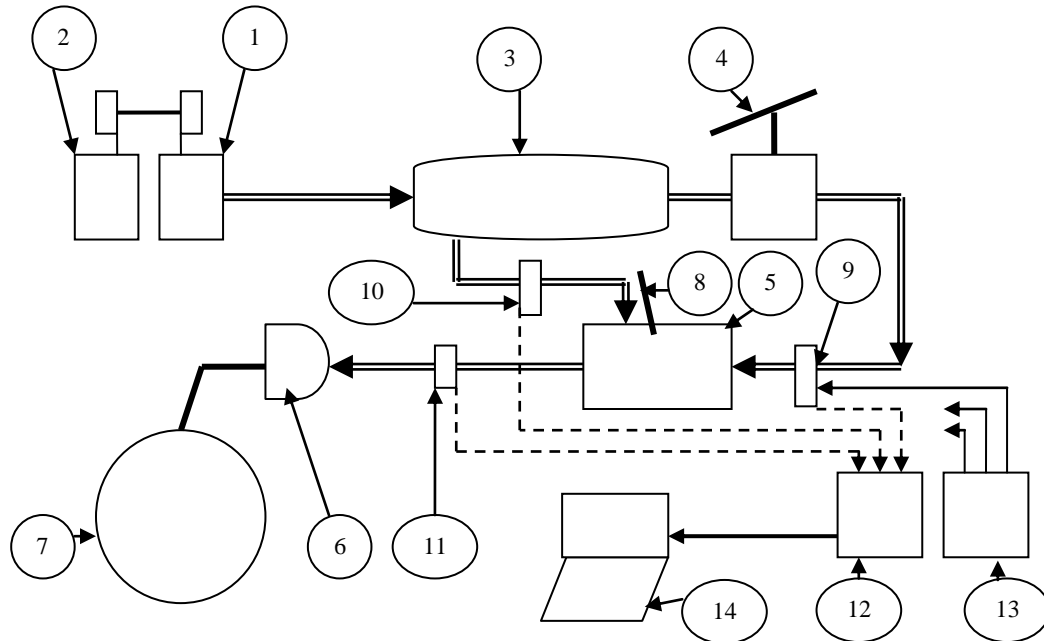

- 1- Air compressor
- 2- Electric motor
- 3- Air tank (reservoir)
- 4- Brake foot valve (treadle valve)
- 5- Load sensing relay valve
- 6- Rear brake chamber
- 7- Rear axle wheel
- 8- Load sensing lever with index plate
- 9, 10, 11 – Pressure transducers
- 12- Data acquisition board
- 13- DC supply
- 14- PC.

**Figure (2):** Layout of test rig [11].

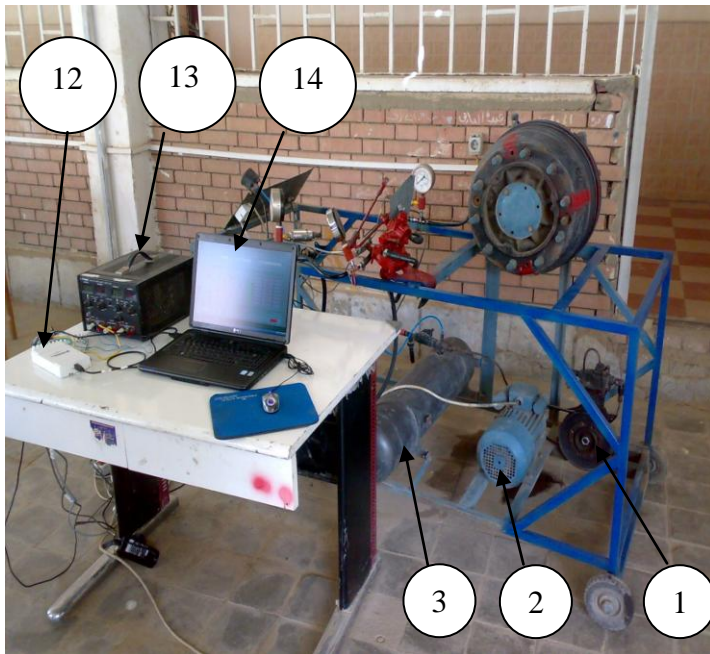

**Figure (3-a):** Air brake system components

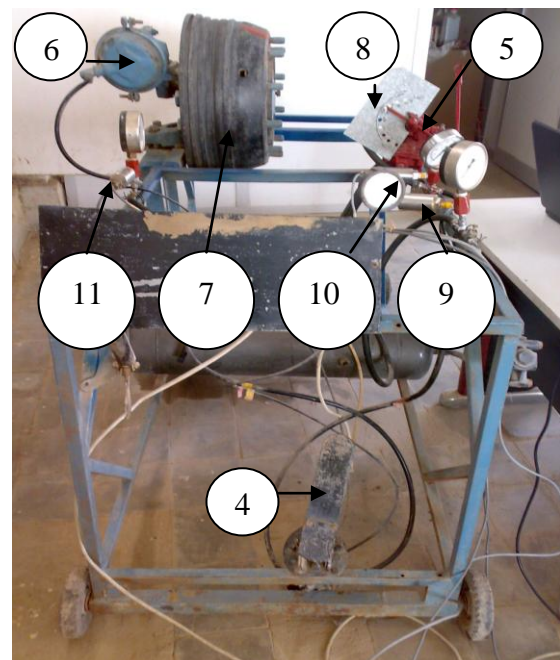

**Figure (3-b):** Data Acquisition System Components [DAQ]

**Figure (3):** Test rig

## 2.2 The Measuring Instruments

Test rig is equipped with several measuring instruments, which are necessary for performing the tests. The measuring instruments, shown in Fig. (3) include:

### 2.2.1 Pressure transducers:

A pressure transducer is mounted at the entrance of each of the relay valve (9) from brake foot valve (treadle valve), entrance to relay valve (10) from the air tank, and output of the relay valve (11) by means of a custom designed and fabricated pitot tube fixture. The purpose of this measurement is to evaluate their performance characteristics.

### 2.3 Data Acquisition systems [DAQ].

All the transducers are interfaced with a connector block through shielded cables. The connector block is connected to a DAQ board [12], (connect with computer by USB cable) that collects the data during experimental test runs. This DAQ board can measure (16-channel single ended inputs or 8 channel differential inputs) and can provide two analog output signals. The DAQ board discretizes the analog input signals using an analog-to-digital (A/D) converter (12) and the resulting digital signals are stored in the computer. An application program written in Labview is used to collect and store the data in the computer [13]. DC supply (13) is used to provide pressure sensors with the required electrical volts. All the transducers are interfaced to a lap top computer (14), through an amplifier and signal conditioning devices.

## 3 . RESULTS AND DISCUSSION :

This section presents experimental results obtained in case (I) when the is valve with rear axle chamber and case (II) when the valve without rear axle chamber. The third case is when there is a effect the resulting from leakage in the air brake system. The main objectives to be considered are to evaluate the performance characteristics of the valve, study the effect of pedal travel rate on its performance and to evaluate the delay time of the valve.

### 3.1 Evaluating the Performance Characteristics of Valve.

Figures from (4 to7) show the experimental results of the relationship between treadle valve pressure ( $P_1$ ), chamber brake line pressure ( $P_2$ ), and reservoir pressure ( $P_3$ ), plotted against the brake time in different operation conditions. Fig. (4) represents the behavior of treadle valve pressure, and brake chamber line pressure at the same operation conditions but at different reservoir pressure in two cases, where three stages can be noticed as follows:

#### Stage (1):

During this stage the brake line pressure increases up to the required pressure whose value depends on the loading condition of the vehicle. This stage is called the apply phase, which depends on pedal travel rate and required braking force.

**Stage (2):**

The brake line pressure during this stage is constant. This stage is called the hold phase, affected by reservoir pressure, relay valve parameters and required braking force.

**Stage (3):**

This stage is called the released stage, affected by pedal release rate.

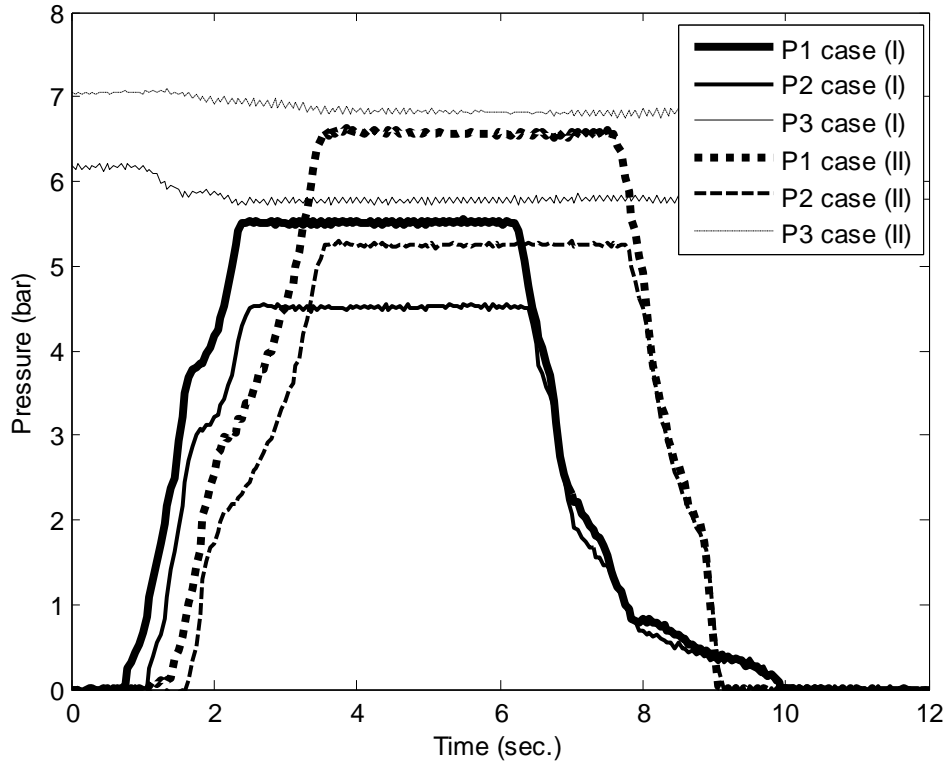

**Figure (4):** Air line brake pressure at half-load in two cases

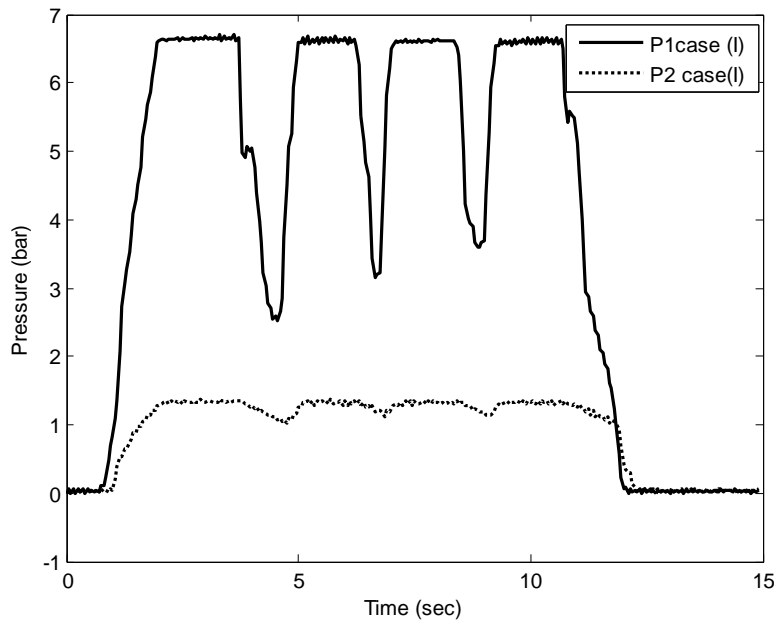

**Figure (5):** Air line brake pressure at (1/3) load in case (I) at variable pedal travel

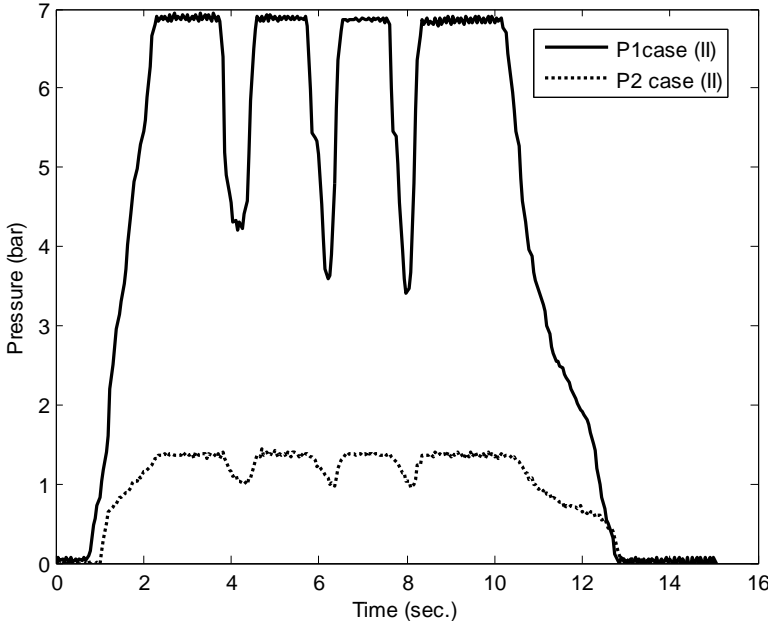

**Figure (6):** Air line brake pressure at (1/3) load in case (II) at variable pedal travel

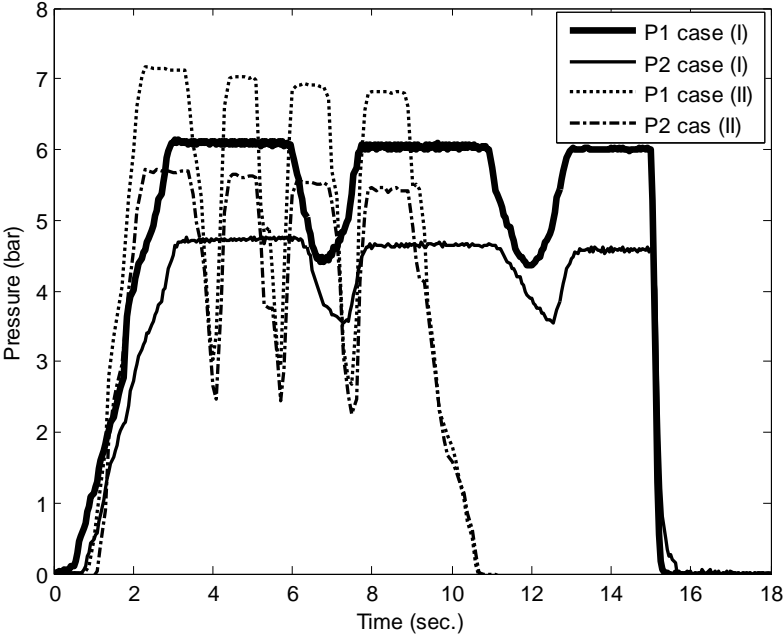

**Figure (7):** Air line brake pressure at half load in two cases at variable pedal travel

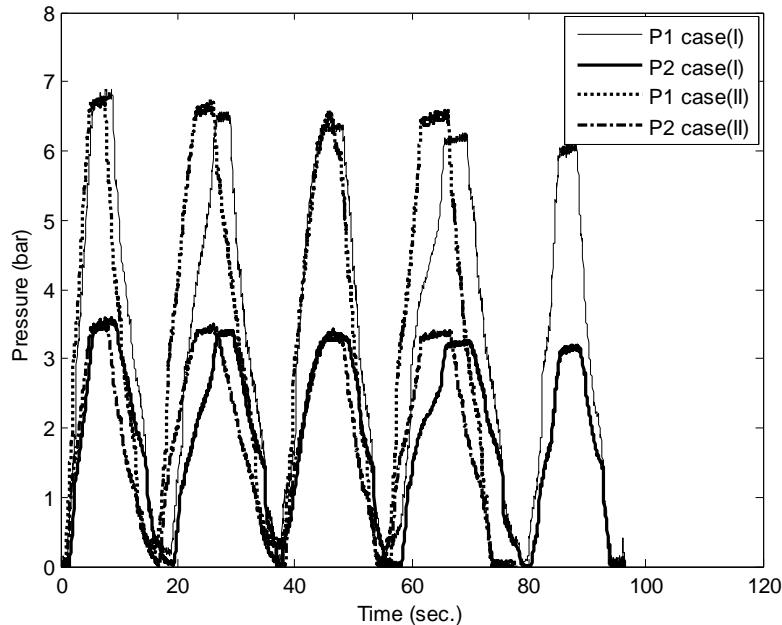

**Figure (8):** Air line brake pressure at no- load in two cases at variable pedal travel

Figures from (4 to 8) show lag time for the chamber brake line pressure with respect to treadle valve pressure, the values of lag time in case (I) and case (II) are 0.101, 0.15, 0.199, 0.25 and 0.049, 0.05, 0.098, 0.1 (sec.) respectively, due to increase delay period of brake system, i. e. increasing the response time of the air brake system there by a increasing stopping distance. One of the important parameters which affect the delay period of air brake system is the brake chamber conditions and pedal travel rate. From these values we can conclude that lag time increases in case (I) and variable pedal travel and decreases in case (II) and slow pedal travel.

Results shown in Fig. (4) show the operation pressure of treadle valve and relay sensing valve effected by reservoir pressure.

From Figs (4 to 8) it can be noted that:

- 1-The brake chamber pressure changes in proportion to loading conditions and treadle valve pressure changes according to reservoir pressure.
- 2-There is a lag time for the outlet pressure of valve with respect to the treadle valve pressure affected by pedal travel rate and brake chamber conditions.

### 3.2 Effect of cam on Air Brake System performance

Figure (9) shows the experimental result in different positions covering the whole loading condition of the vehicle at slow rate pedal travel, and indicates that the performance of valve effected by shape of cam; load sensing cam (10) in Fig. (1).

From Fig (9) it can be noted that performance characteristics of valve affected by the the shape of load sensing cam



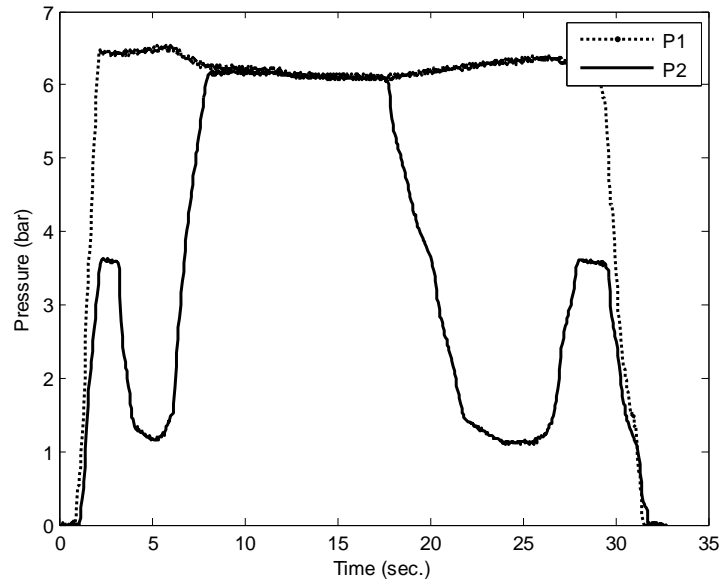
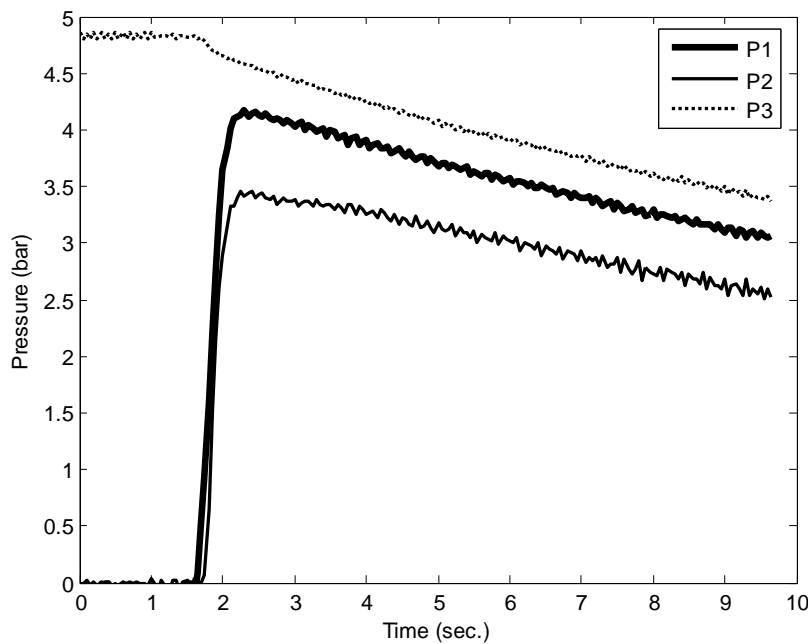

**Figure (9):** Wheel chamber air brake pressure at different loading conditions.

**3.3 Effect of leak on Air Brake System performance**

Figure (10) represents the performance behavior of valve at one position of load, and indicates that the performance of valve is affected by any leak in air brake system, due to decrease in the pressure of each reservoir ( $P_3$ ), treadle valve ( $P_1$ ), and chamber brake line ( $P_2$ ). This means that brake force applied is not proportional to its load due to unstable brake balance [14].

From Figs (10) it can be noted that the performance characteristics of valve affected by the leak in air brake system pressure.



**Figure (10):** Effect of leak in air brake pressure.

## 6. Conclusions:

The measurements performed on the valve using the developed test rig show

- 1- The brake chamber pressure changes in proportion to loading conditions and treadle valve pressure according to reservoir pressure.
- 2- There is a lag time for the outlet pressure of valve with respect to the treadle valve pressure affected by pedal travel rate and brake chamber conditions.
- 3- Performance characteristics of valve are affected by
  - a- shape of load sensing cam
  - b- leak in air brake system pressure.

## References:

- [1] T. K. Garrett, K. Newton, and W. Steed, *the Motor Vehicle*, 13rd ed. Warrendale, Pennsylvania: Society of Automotive Engineers, 2001.
- [2] R. Limpert, *Brake Design and Safety*, 2<sup>nd</sup> ed. Warrendale, Pennsylvania: Society of Automotive Engineers, 1999.
- [3] Darbha et al." *A Diagnostic System for Air Brakes in Commercial Vehicles*", *Intelligent Transportation Systems*, IEEE Transactions on Volume 7, PP. 360 – 376, Issue 3, Sept. 2006.
- [4] Truck and trailer braking systems.  
<http://www.freepatentsonline.com/4078844.html>
- [5] Load-dependent braking force control device.  
<http://www.patentgenius.com/image/4223955-3.html>
- [6] Brake Calculation Software for Commercial Vehicles. 1998. <http://www.vehicular.isy.liu.se/>
- [7] Mechanical Load – Sensing Valve with Relay Valve  
[http://www.wabcoauto.com/products\\_and\\_systems/products-systems-valves](http://www.wabcoauto.com/products_and_systems/products-systems-valves).
- [8] Natarajan et al, "*Model of The Relay Valve Used In an Air Brake System*" , Department of Mechanical Engineering, Texas A&M University, January 2007.
- [9] Subramanian et al, "*Development and modeling of an electropneumatic brake system*", *Intelligent Vehicles Symposium*, IEEE, June 2009.
- [10] Zhang et al, "*Modeling and simulation of a pneumatic brake system*", *Intelligent Vehicles Symposium*, IEEE, June 2009.
- [11] El-Haddad et al, "*Modeling of air brake load sensing relay valve*", Ain Shams University. Faculty of Engineering Vol. 2, October, pp.227-236, 2009.
- [12] National Instruments "*Data Acquisition systems*" <http://www.ni.com/digitalio/>
- [13] G. W. Johnson and R. Jennings, *Labview Graphical Programming*, 3rd NewYork: McGraw-Hill, 2008.
- [14] Nosseir et al, "*Proper Utilization of Load Sensing Valve to Improve Brake Performance*", Ain Shams University. Faculty of Engineering, Vol. 40, No.2, PP. 823-843, June 30, (2005),.