

Military Technical College
Kobry El-Kobbah,
Cairo, Egypt.



13th International Conference
on Applied Mechanics and
Mechanical Engineering.

BASE CONDITIONS OF MULTISPINDLE HEAD DESIGN

HRUŠKOVÁ* E., VELÍŠEK** K. and KOŠŤÁL***P.

ABSTRACT

In this article, the structural relations between particular multispindle head parts are analyzed. The accurate principles and calculations create the base conditions for the development of an optimal engineering design of multispindle operational heads (MSOH). These conditions are the same as required from MSOH producer by users.

KEY WORDS

Multispindle operational head (MSOH) elements, Structural graph, Requirements on the MSOH design

* Research worker, Institute of Production Systems and Applied Mechanics, Slovak University of Technology, Rázusova 2, 917 01 Trnava, Slovak Republic

** Professor, Rázusova 2, 917 01 Trnava, Institute of Production Systems and Applied Mechanics, Slovak University of Technology, Slovak Republic

*** Assoc. Prof., Institute of Production Systems and Applied Mechanics, Rázusova 2, 917 01 Trnava, Slovak University of Technology, Slovak Republic.

INTRODUCTION

Multispindle operational heads (MSOH) belong to the single-purpose machine modular systems. They are positioned using the fixture elements to the machine spindle (Fig. 1).

By multispindle operational head, it is possible to machine several holes at the same time. These holes can have the same or different diameters. As well as, they can be located in regular (rectangular or circular area) or in irregular positions. It means that multispindle operational heads are suitable for drilling holes in very accurate positions. The operation of several clamped work pieces is realizing at the same time or with multispindle tools, i. e. all fixture parts in the tool are machined during one working cycle. MSOH influences the increase of machine production as it is proportional to the spindle number.

Solution of MSOH using the software design makes work for designers easier and more effective therefore the preparation time before MSOH assembling reduces.

CLASSIFICATION OF MSOH

Multispindle operational heads can be divided into two basic types [4]:

- arranging type with changeable span and number of spindles, e.g. fy. NAREX Praha, Inc. offers two spindles with the designation of MSH2, three spindles with the designation of MSH3,
- special type characteristic by specific requirements.

Generally, the minimal spindle span of MSOH by which it is technically possible to assembly it, is used. The outgoing splinter from one operation cannot influence the next operation. It is very important to take into account the spindle span because the spindles have specific diameters and they must be put in bearings according to their parameters. To the significant parameters belong the shape and the roughness which are given in workpiece production drawing. The shape is important for selection of the type of technological operation and consequently for determination of specific head type. MSOH can be divided by technological operation to the heads for:

- drilling,
- inside boring,
- thread cutting,
- combination of them.

PARAMETERS OF MSOH

Apart from the shape, the workpiece roughness represents the next relevant parameter. The utilization of specific tool is influenced by roughness.

Based on this parameter, the sequence and the application of individual parts of MSOH modular system are defined. Selection of individual parts of MSOH modular system depends on the following parameters:

- gearbox of MSOH,
- working spindles of MSOH,
- intermediate shafts of MSOH,
- flume shaft of MSOH,

- gear wheel,
- lubrication,
- power unit of MSOH,
- other parts of MSOH.

The basic information for the head design are obtained from the process plan and production drawing. By these data, it is also possible to define a tool (type of working spindle) and other parts (tool carriage).

Dimension of power unit are calculated from the cutting forces taking into account lubrication. Consequently, characteristics of the power unit form the input data for flume and intermediate shafts dimensioning.

For determination of gearbox size, it is necessary to know which gearing are applicable for:

- chosen type of multispindle heads
- required operating speeds
- defined axis distance of spindles.

All required parameters can be obtained from an exact and time consuming assessment of strength and particular geometrical dimensions.

REVIEWING OF GEARING ESTIMATION

After obtaining parameters and geometrical characteristics of shafts and gearbox, the dimensions of multispindle head can be determined. This procedure creates the first step in the process of multispindle head design. Operating speed is chosen approximately for diameter of 10 mm. Using this operating speed, the operating speeds of intermediate transmission unit and the main shaft are backward calculated. For computed operating speeds, the transmission and subsequently gearing of electromotor are selected according to powers of single transmission units and magnitudes of torques.

MATERIAL DESIGN OF GEAR

For spiral gearing and straight gearing which are most frequently applied in multispindle heads, the nitrided gears made of STN 415230.9 steel are used. These gears are suitable for small modules, they are resistant to bending stress and abrasion and to the seizure as well.

Spiral gearing operated in silent fluent running has smaller dimensions than gearing with straight sprockets. Using spiral sprockets, a similar sprocket profile is developed like by the application of cogwheels. However, the price and more expensive production belong to their disadvantages. Moreover, gear bearing must be resistant to the force acting in gearing.

In spur gear, the mesh of two gear teeth occurs at the same time what results in excitation of vibrations and higher noisiness of gearing. Contrary to spiral gearing, no

axial forces are generated which should be eliminated by the suitable selection of bearing or with constructional setup of toughness.

It can be concluded that the best way is to use spiral gearing with silent fluent running and the highest powers.



PROCESS DESIGN OF MULTISPINDLE OPERATIONAL HEADS

Due to the increase in automation, the designers start to exploit ever more simulation of production and production accessories. In our Institute, the design of multispindle operational head is carried out also in compliance with this trend.

The development of a model of functional MSOH parts with the use of created database is directed to automation. This procedure enables to develop different variants of multispindle operational heads considerably easier and faster.

The designed models of parts contain all necessary calculations as toughness, speed ratio, operating speed, etc. Designed parameters of the spur gearing VN with spiral teeth were used for the development of a functional model in the software CATIA V5R16. This model enables multispindle head movement of gearing.

Based on the calculations of spiral gearing, the dimensions of gearbox are designed. In gearbox, gearings, spindles, fastener elements (screw, check nuts) are located. Dimensions of gearbox and spindles depend mainly on the distance between axis of spindles located at the top of intermediate part of the head and on the intermediate wheel. Through this wheel, the torque is transmitted to adjustable spindle to which an output unit (drill tool) is clamped. MSOH design was created of 51 elements which were designed severally.

In the first step, the shaft is inserted and fixed by relation **Fix Component** . The next step consists in insertion of inner race. Then, the axes of the first selected cylindrical surface of a shaft and cylindrical surface of inner race are aligned by the function **Coincidence Constraint** . In the following step, the face surface of a shaft and the face surface of inner race are selected using the command **Offset Constraint**. A dialogue box with the item **Offset** is opened into which the value of off-set for selected surfaces (in our case 47.09 mm) is entered (Fig. 3).

By creation of the next parts for/of long shaft, the final model of intermediate unit was completed (Fig. 4).

Using the same procedure, further intermediate systems of particular components of multispindle operational adjustable drilling head are modelled. The final system of MSOH is illustrated in Fig. 5.

CONCLUSIONS

In this article, the input data for design and assembling of multispindle operational head are analysed. All these data create the first step for MSOH design. It is important to

determine in detail all parameters, workpiece material and technological operations for which the MSOH is supposed to be applied.

Based on the advanced analysis and assessment of all parameters and elements of MSOH modular system, the selection of particular components from the modular system database is accomplished and various alternatives of MSOH design are created. According to the requirements of MSOH user, the specific variant for manufacturing of a certain product is chosen.

The described process of MSOH design represents a progressive method leading to the increase of production efficiency and costs reduction.

ACKNOWLEDGMENT

The research has been supported by VEGA MS and SAV of the Slovak Republic within the project: **VEGA 1/3193/06 - Multifunctional manufacturing and assembly cell.**

REFERENCES

- [1] Pastierovič, M.; Pecháček, F.: Modular fixture systems. Sectional fixative system. In: Materials Science and Technology - ISSN 1335-9053. - Roč. 5, č. 1 (2005)
- [2] Charbulová, M.; Pecháček, F.: Modular Clamping Systems. In: Proceedings on CD-ROM of 7th International Conference „Research and Development in Mechanical Industry – RaDMI 2007“. Belgrade (Serbia) - Trstenik: High Technical Mechanical School of Trstenik, 2007, p. 149 – 153, ISBN 86-83803-22-4
- [3] Multispindle drilling and tapping heads, Technik 1/2000, str.26
- [4] Košťál, P.: The structure of multispindle operational heads and the generation of its variant design, In: Informacionnye tehnologii v inovacionnykh projektach. Meždunarodnaja konferencija, Iževsk 2001
- [5] Leparov, M.; Dinev, G.: Formalization of the process of mechanical product assembling, In: ICESA 94 Ostrava, 1th International Conference of Engineering Sciences and Applications, Ostrava 1994, Czech Republic, pp. 80 – 85

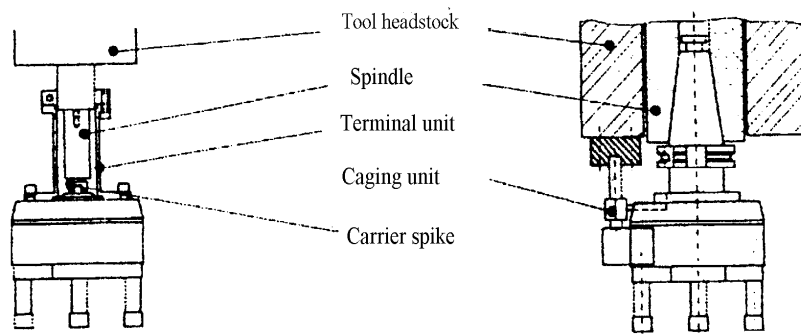

Fig. 3 Multi spindle operation head to machine clamping parts [1]

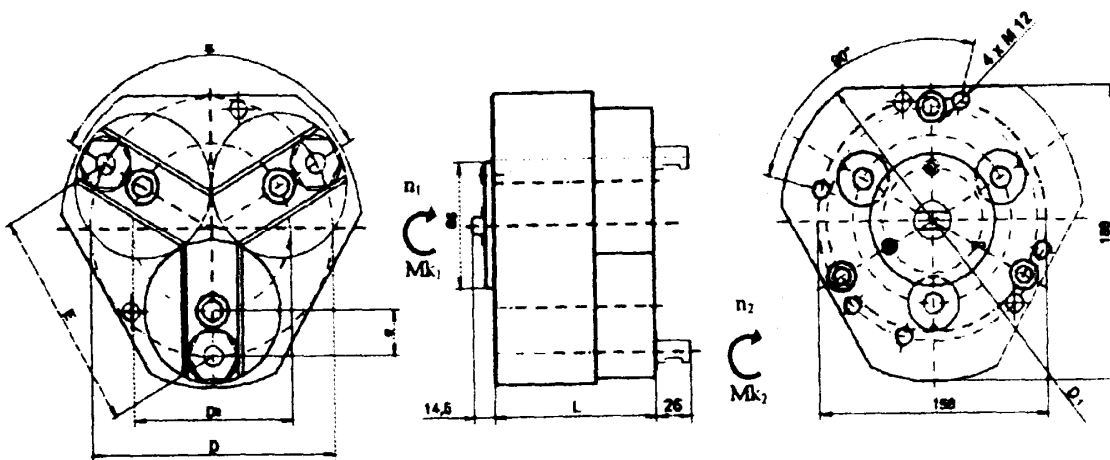

Fig. 1 Parameters of multispindle head [1]

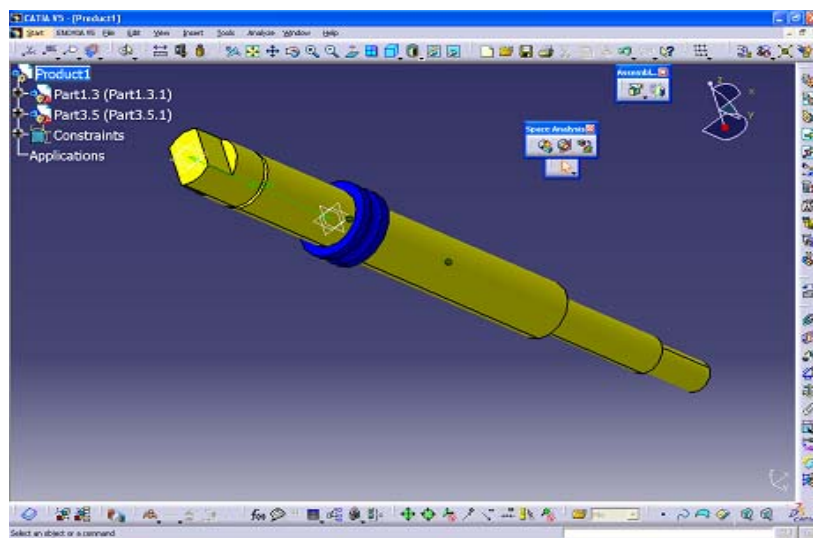

Fig. 2. Alignment of components axes and off-setting.

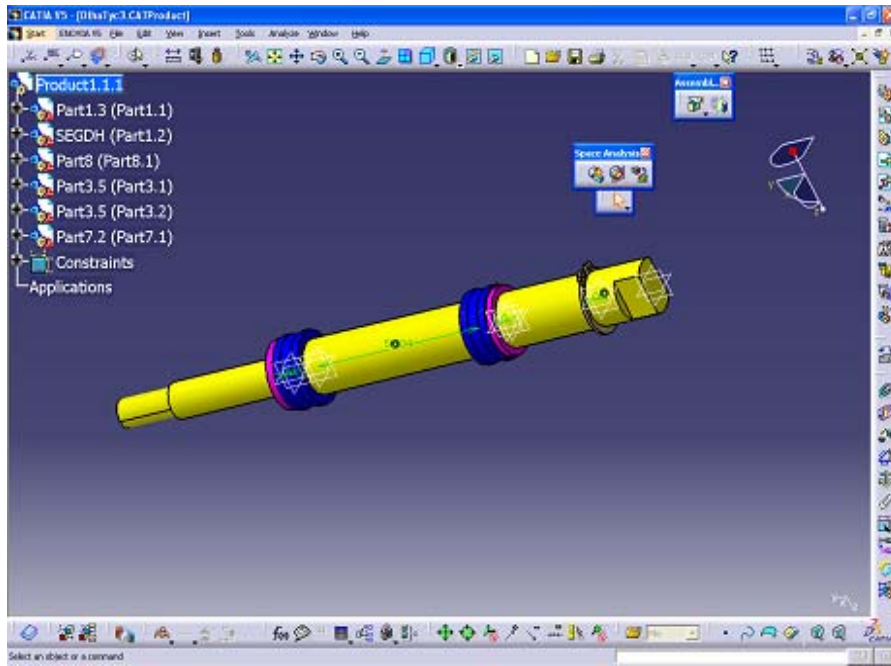

Fig. 4. Final system of shaft for intermediate unit.

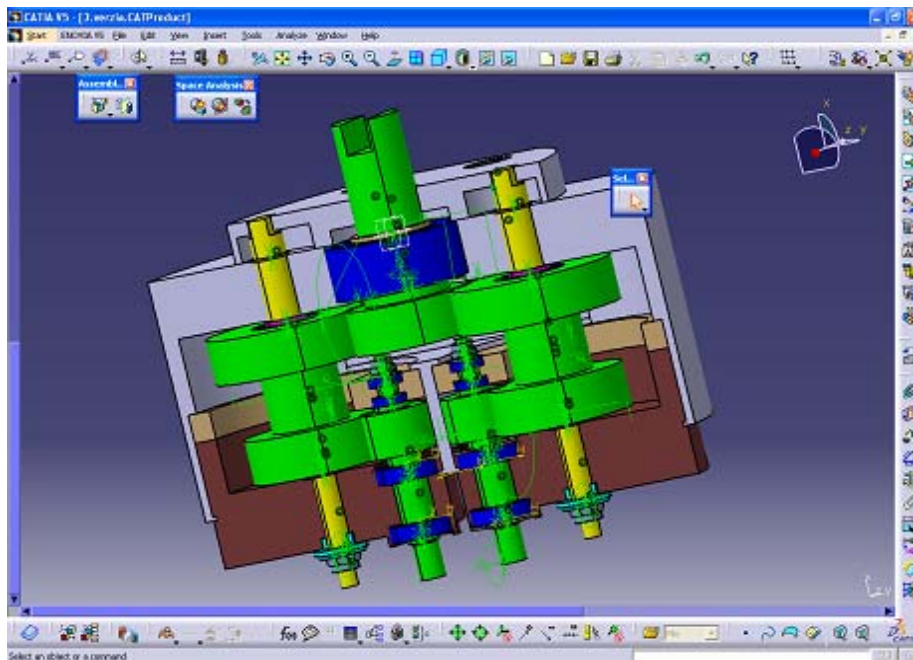

Fig. 5. Final system of adjustable multispindle operational head.