

## **INFLUENCE OF SOME FACTORS AFFECTING CARROT HARVESTING**

**Amin E. A.; Z. E Ismail. T. H.El-Shabrawy H.S. Faleih**  
**Dept. Fac. of Agric. Mansoura Univ., Egypt.**

### **ABSTRACT**

The digging harvesting machine was modified and tested to perform the effect of harvesting speeds on harvesting carrot as lifting, un-lifting, damaged, un-damaged and machine productivity. These indicators were evaluated under condition of medium at El Dakahlia Governorate in Belqas, Egyptian. A lot of the experimental field were conducted on carrot harvesting under three different levels of separator length (450, 700 and 1200mm); reciprocated cam with link length of 180, 210 and 240 mm and three forward speeds (3.6, 5.1 and 7.2km/h) and three share (Sweeping, Nose and Shovel). The obtained results concluded that the maximum value of carrot lifting efficiency was 99% recorded at nose shape type, 3.6 km/h harvesting speed, separator length 1200mm and reciprocated cam with link length of 210mm. At reciprocated cam with link length of 180mm, increasing forward speed from 3.6 to 7.2 km/h increased the un-lifted of 6, 7 and 9% times at separator length of 450, 700 and 1200mm respectively. Generally, increasing harvesting speed increased carrot damage. For example, recorder less value to damage 1.99at forward speed3.6km/h, sweeping shape type, reciprocated cam with link length of 180mm and length separator 450mm. while recorded highest value to mechanical damage 10% at forward speed 7.2km/h. By increasing forward speed from 3.6 to 7.2 km/h decreased productivity under all treatments at reciprocated cam with link length of 180, 210 and 240mm.

### **INTRODUCTION**

In order to improve the mechanization on carrots, a double-rows self-propelled carrots combine harvester was designed based on carrot agronomic requirements Wang and Sheng (2012). The functions of the combine included digging, clamping and conveying, separating roots from leaves, removing soil and collecting carrots. Farmers have to make the most of available resources. The digging nose was designed as triangle shape of two wings open so as to reduce the operating resistance. Before separating roots from leaves, carrot plants were conveyed into a drawing device to align the roots, and then transformed to a horizontal conveying belt and to be cut by double disc cutters. The prototype harvesting tests in field showed that carrots collecting rate was 98.2%; carrots damage rate was 2.5%; the productivity of combine reached 0.11 ton per m<sup>2</sup>h. This research provides a reference for further research and development of carrot harvesters. With the lowest speed of the harvester (0.26 m/s), all the carrot roots were removed from the soil and no broken roots were found in the collected material. Losses caused by root loss were 6.8%, while damage of the roots caused by their breaking was 2.6%.

The vines between the rows of some varieties. Flails are contoured to fit the rows. Several types of mechanical diggers exist and still are being used

to lift carrot out of the ground. The simplest machines are patented after a low flat-bed type carrot digger, (Misener, *et al.*, 1984).

Maksimov *et al.* (2006) design an equipment mounted on carrot digger KST-1. It is outlined comprising parts for digging and pressing out of carrots and a separating module. An illustration is provided of the carrot digger designed in Russia with fork-type pressing out and elevator diggers. Technical characteristics and principles of design are outlined. Investigations were conducted by Kowalczyk and Leszczyniski (1999) to evaluate the quality of carrot harvesting using a single-row harvester, ALINA, manufactured in Poland. The tests were carried out at harvester working speed 0.25 m/s. Harvesting losses and mechanical damage to carrots were determined. Results showed that total losses of carrots amounted to 5.3% (1.5% of which were left in the ground and 3.8% were lost during harvest). Total damage was 22.0% (8.0% of which was cracking and 14.0% breaking). On the other hand, the effect of the working speed of a one-row harvester ALINA Company on the yield quality of carrot "Joba sort" roots was determined by Kowalczyk *et al.* (2001a). An increase in the speed of the harvester within the studied range (0.26-0.64 m/s) had a significant effect on greater losses caused by the fact that the roots were not removed from the soil and they were damaged and on reduced inorganic contamination in the collected material. No significant effect was observed of the working speed of the harvester on the losses caused by the root loss and on the quality of root heading. With the lowest speed of the harvester (0.26 m/s), all the carrot roots were removed from the soil and no broken roots were found in the collected material. Losses caused by root loss were 6.8%, while damage of the roots caused by their breaking was 2.6%. Also, Kowalczyk *et al.* (2001c) conducted the experimental field and determined the quality of carrot roots harvesting with a Simon single-row harvester that manufactured in France. The overall root losses reached 4.1%, including roots left in the soil (2.7%) and those lost during harvesting (1.4%). Within the harvested material, 18.4% were broken roots and 29.7% were roots with leaves. The impurities comprised 2.5%, including 0.9 and 1.6% organic and inorganic impurities, respectively. On the other side, Kowalczyk *et al.* (2001b) considered the assessment of the influence of a one-row Simon harvester's operating speed on the quality of carrot roots harvesting very important. The root losses were lowest (2.7%) at the harvester's operating speed of 0.53 m/s, while the lowest root damages (53.1%) and least impurities within the harvested material occurred at the speed of 0.42 m/second. Details are given of the design of a separating device developed and patented in Russia (patent no. 2095960) by Maksimov *et al.* (2000) for use in carrot harvesters. It consists of a drum, the rear half of the outer elastic surface of which bends round a bar-elevator, while in the upper part of the drum a finger belt with a guide roller forms a separating unit. The working process is explained, and calculations of the design parameters are presented, including the pressure of the elevator bars on the drum. The tension of the elevator should be such as to provide a pressure of the bars on the drum surface equal to 245-285 N. This is sufficient for complete disruption of soil clods (117-245 N), but is less than the force which would crush the carrot (300-600 N). The effects of different

mower speeds (2358, 2440 and 2553 rpm) and different knife angles (30°, 40° and 50°) on sweet potato vine pulverization were studied by Amer *et al.* (2013). The results indicated that all the treatments were significant for the pulverized percentage of carrot vine. The 30° knife angle gave the best result with highest vine pulverized percentage of 54.60 %, and a mower speed of 2553 rpm had the finest vine pulverized percentage of 46.99 %. The best performance for interaction effect between knife angle and speed of mower was achieved by the 30° knife angle and a mower speed of 2440 rpm resulting in an average percentage of 61.27% of pulverized vine. Also, Waszkiewicz *et al.* (2004) studied the effects of the ground speed of a one-row combine, speed of the separating web, and scraper position in the mechanical separator on damages, losses and contamination of carrot roots during mechanical harvesting were determined. Web speed affected significantly the losses of un-lifted roots and the roots lost on the separating web and transverse conveyor. However, the root losses on the mechanical separator depended on its setting and web speed. The carrot root losses significantly depended on the position of the scraper in the mechanical separator, while the change in ground speed of the tractor-machine outfit did not affected significantly the change in the values of quality indices.

## MATERIALS AND METHODS

This study was conducted in two stages; the first one is modified of harvester parts which was manufactured and adjusted at workshop of Agri. Engineering Dept., Mansoura University. The second stage is that, conducted experimental field to evaluate harvesting machine at El Dakahlia Governorate a private farm in Belqas region in season of 2012-2013. The soil specification was tabulated in table (1).

**Table (1): Soil specification and moisture content of field in Belqas region:**

Soil components				Mc% "wb"	Soil structure
Clay %	Silt %	Coarse sand %	Fine sand%		
41	34	6	19	13.2	Sand clay loam

### The designed unit operation

The ordinary carrot harvester faces many disadvantages during carrot harvesting then some considerations are taken in our mind such as:-

- 1- The design should lead to develop a digger that realizes minimum damage, maximum lifting and productivity.
- 2- The digger should improve harvesting efficiency with adequate safety and reduce drudgery in harvesting.
- 3- The root crops digger should be able to operate down depth of 240 mm, to suit the harvest depth for carrot and width of 500 mm, to suit the width of carrots planting line.

**General description of novelty carrot harvester**

The proposed harvesting unit was developed on the basis of one row digging harvester with the main parts as shown in Figures (1 and 2).

**Frame:** It is made of squared steel with dimensions of 50 × 50 × 7mm. It takes a rectangular shape (600 × 550mm) and it includes elements to convey rotary movement from tractor PTO to a cam. The hitching system was connecting with the front frame and it was supplying with digger and elevators. The digger frame is holding with two tire wheels of 600 mm diameter and 100 mm thickness.



1- Frame 2- Digging blade 3- Separating 4- Transmission unit 5- Reciprocating link

**Figure (1): Digging harvesting components**

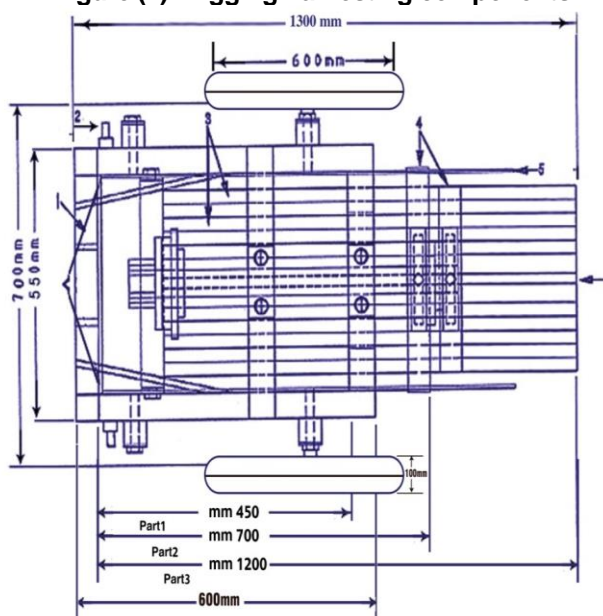

1- Share 2- Hatching points 3- Strips 4- Two longitudinal frames 5- Share frame 6- Separating unit

**Figure (2): Plane view of digging harvesting (scale 1:10)**

**Digging blade:** Three forming digging shape was investigated as shown in Figure (3-A, B and C), made from steel sheet with constant till angels of (21°) and operating width of 500m.

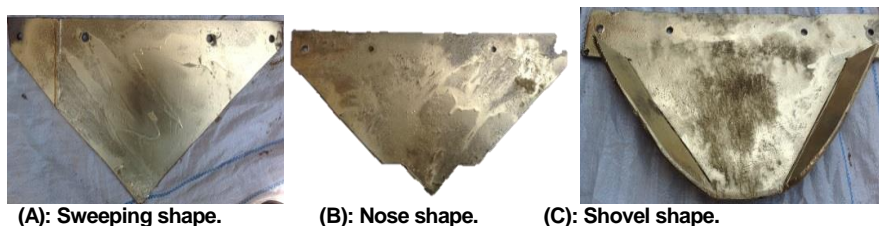

**Figure (3):The different shapes of digging blade.**

**Separating unit:** It consists of a frame with three different splits 450, 700 and 1200mm length with constant width of 500mm, 8 mm thickness. It contains 7 stripes each with 25 mm and the distance between strips 10 mm. This frame is connected to the vibrating blade with fixable joint. as shown in figure (2 – part1, part2 and part3).

**Transmission system:**It having main shaft transmit rotational cam motion to generate a vibrating motion. The arm of four bar linkage was adjusted with three different link length (180, 210 and 240mm) to get three different of reciprocating motions. The developed digger connected with a three points hitch of a 48.51 kW (65 hp) tractor.

**Experimental studied factors:**

A lot of experimental field were conducted on carrot harvesting further down three different levels of separator length (450, 700 and 1200mm); reciprocated cam with link length of 180, 210 and 240mm and three forward speeds of 3.6, 5.1 and 7.2km/h under different three shapes of digging blade (Sweeping, Nose and Shovel share).

**Measurements**

**Lifted and un-lifted efficiency (Li):** They were recorded after harvesting operation done per every variable for the experimental groups. Carrot tuber lifted ( $M_1$ ) and un-lifted ( $M_2$ ) collected and weighted. There were calculated from the following equations:-

$$Li \% = \frac{M_1}{M_1 + M_2} \times 100 \text{ -----(1)}$$

**Mechanical damage (MD):** The percent of mechanical damage may be determined using the following formula:

$$MD, \% = \frac{M_3}{M_3 + M_4} \times 100 \text{ -----(2)}$$

Where:  $M_3$ : mass of damaged root crops.

$M_4$ : mass of root crops which have no bruise or cutting.

**Un- damage:** It was calculated using the following equation:

$$UD, \% = \frac{M_3}{M_3 + M_4} \times 100 \text{ -----(3)}$$

**Machine productivity:**The tubers per unit harvesting area were collected, weighted and then the ratio between the unit area and field was determined hence, the machine productivity was calculated.

## RUSULTS AND DISCUSSION

### 1-Carrot root Lifted Efficiency%

Data demonstrated in Fig (5) showed that, the highest value obtained for lifted carrot percentage tubers (99%) with Nose share and longest separator length 1200mm at 210mm reciprocating link length. This could be as a result of ability of this share to penetrate the soil during harvesting process and increasing chance of separation soil adhesion on tubers with increasing separator length. On the other hand, shorten length of separator and increase the link length reciprocating had a negative impact on carrot lifted percentage value (Un – lifted percentage), also data showed that the highest value of un-lifted tubers (12%) obtained with shovel share type with shortest separator length 450 mm and 240 mm reciprocating link length. It can say that the shovel share type had high resistance of soil penetration and give off a lot of soil with tubers during harvesting process, on the other side the shortest separator and lowest link length reciprocating had a little efficiency of separate soil from the tubers.

Generally, increasing forward speed from (3.6 to 7.2 km/h) decreased the lifted tubers.

### Mechanical Damage and Un-Damage Percentage%

From the mentioned data demonstrated in fig (6), one can say that, the lowest value of carrot tubers damage (1.99%) obtained at sweeping share with shortest separator length 450mm, and lowest link length reciprocating, this may be due to sweeping share had a shape with easy penetration of the soil and thus little friction with tubers at lowest forward speed 3.6km/h led to little carrot tubers damage also the shortest separator with lowest link length reciprocating reduce collisions between tubers and machine material led to lower tubers damage percentage on the other side used shovel share with highest forward speed (3.6km/h), and longest separator length 1200mm with high link length reciprocated 240mm due to highest value of tubers damage 10%, this could be as a result of increasing the friction between tubers and share material during harvesting process at exactly at highest value of forward speed (7.2km/h), and longest separator with highest link length reciprocating 240mm led to high friction between tubers and machine materials which due to tuber damage percentage %.

**Figure (5): Lifted efficiency % at different share types under study.**

**Figure (6): Damage efficiency % at different share types under study.**



**Harvesting productivity:**

From mentioned histograms data showed in fig (7), one can notes that recorded high productivity ( $P, = 15.45$  tan/hectare), at forward speed 3.6km/h with Nose shape type for easy penetration of the soil and high value of lifted tubers efficiency %, with link length reciprocating 210mm To separate the soil from the tubers without dispersion and length separator 1200mm for more tubers lifted and without soil adhesion.

**Figure (7): Productivity tan/hectare of sweeping share.**

**Figure (8): Productivity tan/hectare of nose share.**

**Figure (9): Productivity tan/hectare of shovel share.**

### **CONCLSION**

**The conclusions of this study are summarized as follow:**

- 1-The maximum value of carrot lifting efficiency was 99% recorded with nose shape type at 3.6 km/h harvesting speed, reciprocated cam with link length of 210mm and length separator 1200mm.
- 2-Increasing forward speed from 3.6 to 7.2 km/h increased the percentage of un-lifted from 9 to 12%, at shovel shape type, reciprocated cam with link length of 240mm, length separator 450mm
- 3-Generally, increasing harvesting forward speed increased tuber damage.
- 4-The highest productivity Recorded 15.45tan/hectare with nose shape type, forward speed 3.6km/h. And vice versa when increasing harvesting forward speed from 3.6 to 7.2km/h decreased productivity.

## REFERENCES

- Amer, N. N.; D. Kakahyet, M. D Akhir and A. Ishak.(2013). Pulverization of sweet potato vine at different mower speeds.Mechanization and Automation Research Center, MARDI, Serdang, Selangor, Malaysia.
- Kowalczuk, J and N. Leszczynski.(1999). Evaluation of the quality of carrot root harvesting with Alina harvester manufactured in Poland.ProblemyInzynieriiRolniczej; 7: 4, PP 19-24.
- Kowalczuk, J.; N. Leszczynski and J. Zarajczyk. (2001a). The effect of the working speed of local harvester for the harvest of carrot on the losses and damage of the roots. AnnalesUniversitatisMariae Curie-Sklodowska. Section E, Agriculture; 56: PP 221-227.
- Kowalczuk, J.; N. Leszczynski and J. Zarajczyk. (2001b). The influence of a Simon harvester's operational parameters on the quality of carrot roots harvesting. InzynieriaRolnicza; 5: 13, PP 218-222.
- Kowalczuk, J.; N. Leszczynski and J. Zarajczyk.(2001c). Analysis of the losses and damages of carrot roots harvested with a Simon single-row harvester.InzynieriaRolnicza; 5: 1, PP 141-145.
- Maksimov, L. M.; P. L. Maksimov and A. A. Myakishev. (2000). The separating device of a carrot harvesting combine .Russia. Traktory i Sel'skokhozyaistvennyyeMashiny; PP 12, 12-13.
- Maksimov, L. M.; P. L. Maksimov and L. L. Maksimov.(2006). Combine harvester for harvesting carrot .Russia.Kartofel' i Ovoshchi; 5, PP 22-23.
- Misener, G.C.; C. D.Mcleod and L. P. Mcmilan.(1984).Evaluation of potato-type potato harvester. Trans. ASAE (Am. Soc. Agric. Eng).27(1): 24-28.
- Wang, J. S and S. sheng. (2012). Development and experiment of double-row self-propelled carrots combine. Transactions of the Chinese Society of Agricultural Engineering; 28: 12, PP 38-43.
- Waszkiewicz, C.; A. Lisowski and A. Struzyk. (2004).Effect of technical and exploitation parameters of root crop combine harvester on quality indices during harvesting of carrot roots. Annals of Warsaw Agricultural University, Agriculture (Agricultural Engineering); (45): PP 23-27.

## تأثير بعض العوامل التي تؤثر على حصاد الجزر عماد الدين أمين عبد الله زكريا ابراهيم اسماعيل طارق حسني الشبراوي وهشام سامى فالح قسم الهندسة الزراعية - كلية الزراعة - جامعة المنصورة

تم تعديل آلة الحصاد الجزر واختبار تأثير سرعة الحصاد وشكل السلاح وطول ذراع جهاز التردد وطول جهاز الفصل على جودة حصاد جذور الجزر المحصودة وغير المحصودة، والتألفه وغير التألفه، وإنتاجية الآلة. تم تقييم أداء الآلة في مزرعة خاصة في منطقة بلقاس بمحافظة الدقهلية، جمهورية مصر العربية. وقد أجريت الكثير من التجارب الحقلية على حصاد الجزر تحت ثلاثة مستويات مختلفة من طول وحدة الفصل (450، 700، 1200 مم)، ثلاث أطوال لذراع الكامة الترددي (180، 210، 240 مم)، ثلاث سرعات أمامية (3.6، 5.1، 7.2 كم/ساعة) وثلاثة أنواع مناسبة الحصاد (Sweeping, Nose and Shovel share). وكانت النتائج المتحصل عليها:

1. أقصى قيمة لكفاءة الجذور المرفوعة من الأرض 99% سجلت مع سلاح من نوع (Nose) عند الحصاد بسرعه اماميه 3.6 كم/ساعة، وطول الوصلة الترددية 210 مم وطول جهاز الفصل 1200 مم.
2. زادت النسبة المئوية للجذور الغير مرفوعة من 9 الى 12% عند السلاح من النوع (Shovel) مع طول الوصلة الترددية 240 مم وطول جهاز الفاصل 450 مم عند زيادة السرعة من 3.6 الى 7.2 كم/ساعة.
3. بشكل عام عندما تزداد السرعة الامامية تؤدي الى زيادة تلف الدرنات. سجلت أقل قيمة للتلف 1.99% عند سرعة امامية 3.6 كم/ساعة مع سلاح من نوع (Sweeping) عند طول جهاز الفاصل 450 مم وطول الوصلة الترددية 180 مم. في حين سجلت اعلى قيمة من التلف 10% مع سلاح من نوع (Shovel) عند طول جهاز الفصل 1200 مم وطول الوصلة الترددية 240 مم وبشكل عام عند زيادة السرعة الامامية من 3.6 الى 7.2 كم/ساعة تزداد نسبة التلف.
4. سجلت اعلى قيمة للإنتاجية 15.45 طن/هكتار عند سرعة امامية 3.6 كم/ساعة وسلاح من نوع (Nose). والعكس صحيح عند زيادة السرعة الامامية من 3.6 الى 7.2 كم/ساعة تنخفض الإنتاجية.