



FACTORY LAYOUT FOR SMALL METALLIC-DISC MILLS

Gaber M. Sheha^{*} and Ahmed M. Abou El-Einene^{*}

ABSTRACT

Today, a classical mills (natural-stone mills) are Commonly used in the Egyptian rural areas. It is a primitive method for food production and also costly. Recently; the advanced mills (metallic-disc mills) has been developed and the main design problems were solved. This study is an attempt for applying systematic layout planning Techniques in carrying out an advanced factory layout for the small metallic-disc mills in the rural areas of Egypt, as closed as possible to the ideal layout of the mills has been studied. A quick review for the principles and objectives of the "Good plant Layout" has been presented. The available data about this work were collected from the past experience of the existing mills in Egypt Alternative layouts were carried out and the best two has been selected. Finally a detailed layout was proposed. A Suitable comparison chart of the total cost is proposed to help the engineers for deciding the best and the economical Site for building the mill.

INTRODUCTION

At present, the grain milling is being made in the Egyptian rural areas, using the villages flour mills. These mills are constructed mainly of two natural stones, granite is one of the commonly used stones. The stone is of a circular shape, usually consists of several sections which are jointed together by cement. Each of these stone sections should have the same hardness, that is to avoid any irregularity which could have an adverse effect on the quality of the produced flour. Recently, a small metallic-disc mill has been investigated to replace the natural stone mill in Egypt [4]. This investigation is an attempt for applying "Systematic layout Planning Technique" in carrying out a new factory layout for small metallic-disc mills. The objective of "GOOD PLANT LAYOUT" of mills could be satisfied; Greater utilization of machinery, man-power, services, saving in floor space and increasing output.

* Lecturer , Dept. of Production Eng. and Design, Faculty of Eng. and Tech. Menoufia University, Shebin El - Kom, Egypt.

PRINCIPALS OF "SYSTEMATIC LAYOUT PLANNING TECHNIQUES"

It is a very simple technique. It could be summarized as follows ; [1,2,3]

- 1- Apply the "PQRST" Technique; where
 - P : Products which will be produced in the factory.
 - Q : Quantity of products in form of production programme.
 - R : Routing the manufacturing methods.
 - S : Supporting services which will serve the plant.
 - T : Time of finishing each process & the total time of each product.
- 2- From the results of this study & from applying the technique of the converting method, the machines, man-power & equipment needed could be calculated.
- 3- Determine the suitable departments or sections and servicing areas.
- 4- By using the block diagram, the locational relationships between these departments could be governed to realize the efficient movements of products from one area to another & the economic use of area.
- 5- Plot the general layout & the detailed one & modify them.

THE PLANT LAYOUT

- 1- Manufacturing Process Sheet of The Flour Milling.

To realize the objective of the plant layout may be the proposed manufacturing process sheet (See. Fig. 1) used. The machines and the equipments which used to mill the wheat grain have been redesigned and the main operational performance of the mill discussed, They [4] .

- 1- Weigher
- 2- Sieve separator : used to separate straws, sand and foreign seeds.
- 3- Aspiration : used to separate dust, chaff, small straws, light grains and other light particles.
- 4- Scourer : used to remove the adhering dirt out of the grain surface by friction.
- 5- Washer : used to separate the sticking dirt from the surface of the wheat grain and to separate the mud balls.
- 6- Silos : used for conditioning the wheat grain.
- 7- Plansifter : used to separate the bran from the flour.
- 8- Fire equipments .
- 9- Aspiration air equipments.

The economical feasibility of the designed metallic-disc mill has been also discussed Fig. 2 shows the main component of the metallic-disc mill.

- 2- Work-center layout

Incorporated with the plant layout is the workcenter or workplace layout. That deals with what is known as motion study or work simplification. In the case of a small metallic-disc mill containing a small number of machines and equipments, the problem of work-center is solved easily by merely noticing the required total area.

Any workplace can be arranged in several different ways. Each arrangement should be efficient and at the same time fit into the layout plan. Thus, an individual workplace is related to the detailed layout plan, just as the detailed layout plan is related to the overall layout.

The workplace layout for every machine and equipment have been improved due to the following elements :

- 1- Operation analysis;
 - 2- Man-machine process chart;
 - 3- Operator process chart; and
 - 4- Time-motion relation analysis.
- Accordingly, the required floor-dimensions are determined.

3- Having decided on a "suitable" or "best" location, the problem that is to be considered is that of the plant layout. To decide a "suitable" layout,

we have to consider the general engineering procedure that is usually followed. In all such procedures the first item to be considered is the objective. According to engineering fundamentals, a plant layout embraces the physical arrangement of industrial facilities. This arrangement, either installed or in plan, includes the spaces needed for material movement, storage, indirect labourers, and all other supporting activities or services, as well as for operating equipment and personnel.

In small mills, the plant layout offers no problem at all, due to the very limited numbers of machines and operations. The factors influencing the layout may be : [2, 5, 6]

- 1- Quantity of materials, the necessary operations & their sequence.
- 2- Machinery-including the producing equipment and tools and their utilizations.
- 3- The man factor-including supervisor, and direct labour.
- 4- The movement factor-including manual handling at the various operations, inspections and storages.
- 5- The waiting factor-including temporary storages and delays between operations.
- 6- The service factor-including maintenance procedure, scheduling, dispatching, follow-up records.
- 7- The building factor-including the shop of building, windows, floors, and other factors.

The following steps of the layout techniques :

- 1- Statement of problem.
- 2- Collection of data or facts.
- 3- Restatement of the problem in the light of the collected facts.
- 4- Proper analytical procedures are applied in order to reach an optimum or best solution,

After determining the different sections of the factory, the locational relationships between them were determined. The general layout and the detailed layouts for the plant were done in Figs 3 and 4 show the two proposed factory layout for the metallic mills.

CHOICE OF THE SITE

For a small Mills the choice of site is primarily governed by the proper community that provides the most favourable economic features. The second imposing condition is the city or zone regulations that allow such type of constructions. When these two factors are set up, the main general specifications are considered which are :

- 1- Plant layout.
- 2- Description of the building to be constructed.
- 3- Necessary city services such as, road, water, electricity, ... etc.
- 4- Minimum size of required city services of water, gas, electricity, etc.
- 5- Necessary safety regulations that are to be adopted.

In the case where more than one site is available, the choice of a particular site is determined in terms of the lowest costs of production and distribution. If the unit production costs in the various locations are comparable, the location that requires the least capital outlay for fixed investment will be preferred.

The comparison chart (Fig. 5), may serve as a guide in a proper summation of all the cost factors. Then, because every case is different, the engineer must correctly evaluate all interrelated factors and reach a sound conclusion.

In fact, the comparison between different locations is carried out in view of both production and distribution costs and the total return. Other factors, such as ability to meet consumer demands, labour availability, ..etc.

are essentially considered. A mathematical optimum technique may be searched for the provision of a "best" solution.

INDUSTRIAL SAFETY REGULATIONS APPLIED TO MILLS

The mill layout is extremely vital in providing safe working conditions. Safety regulations include the building to be constructed, the actual layout of machines and equipments, and flow of flour between all work-centers. This is because safety is a necessary component of equipment, methods, planning, etc.

Several studies were undertaken to determine the correlation between the safe "decreasing accident rates" and productive "increasing production rates", also between the "safe" working or "unsafe" working with respect to "productive". The result of such studies revealed that a "safe" working is 11 times more likely to be "productive" than is an "unsafe" working. Thus, industrial safety, or "accident prevention" is a vital factor in every mechanical work enterprise.

As a result of these studies, the proof of a strong correlation between safety and productivity, may lead to a correlately that the controlling factors in safety and production are identical. Of these controlling factors are [2, 5]

A- Man performance.

B- Machine or mechanical performance.

Accordingly industrial safety or "accident prevention" represents, control of man performance, machine performance and physical environment.

Thus, accident prevention is a vital factor in small metallic-disc mills.

Thus, accident prevention may be defined as an integrated program, a series of coordinated activities, directed to the control of unsafe personal performance and unsafe mechanical conditions and based on certain knowledge, attitudes, and abilities.

CONCLUSIONS

In this paper an investigation into the planning of flour mills has been conducted. This work is a continuation of a study carried out recently [4], in which the natural stone is replaced by a metallic disc in the Egyptian rurales flour mills.

The main achievements of this work are the determinations of plant layout, choice of the economical site of the plant and the relevant safety regulations.

The results obtained in this paper are useful to the planning and executive engineers.

ACKNOWLEDGEMENTS

The authors wish to express their sincere gratitude and appreciation to Prof. Dr. Abdel-Hady A. Nasser, Dean of the Faculty of Eng. and Tech. Menoufia University, Shebin El-Kom, for his continuous guidance and keen interest, which they have shown during the progress of this paper.

REFERENCES

- 1- Buffa, E.S. "Modern Production Management". John Wiley and Sons, New York, (1973).
- 2- Gaber M. Sheha. "Investigation of Control Techniques Applied to The Production of Small Shops" M.Sc. Thesis, Helwan University, Faculty of Technology at Helwan (1976).

- 3- Maynard, H,B,, "Industrial Engineering Hand Book". McGraw-Hill Book Comp. New York, (1971).
- 4- Nasser, S. Ahmed and A. Abo El-Einene, "Design of Grain Mills (Mills of Medium Size)" Ph.D. Thesis Faculty of Eng. & Tech. Menoufia University, 1983.
- 5- Shubinm I,A. and Madehin, H. "Plant Layout, Development and Improving Manufacturing Plants". Prentice Hall, H,I, (1963).
- 6- Vaughn.C.R. "Introduction to Industrial Engineering". The Iowa State University Press. U.S.A., (1967).

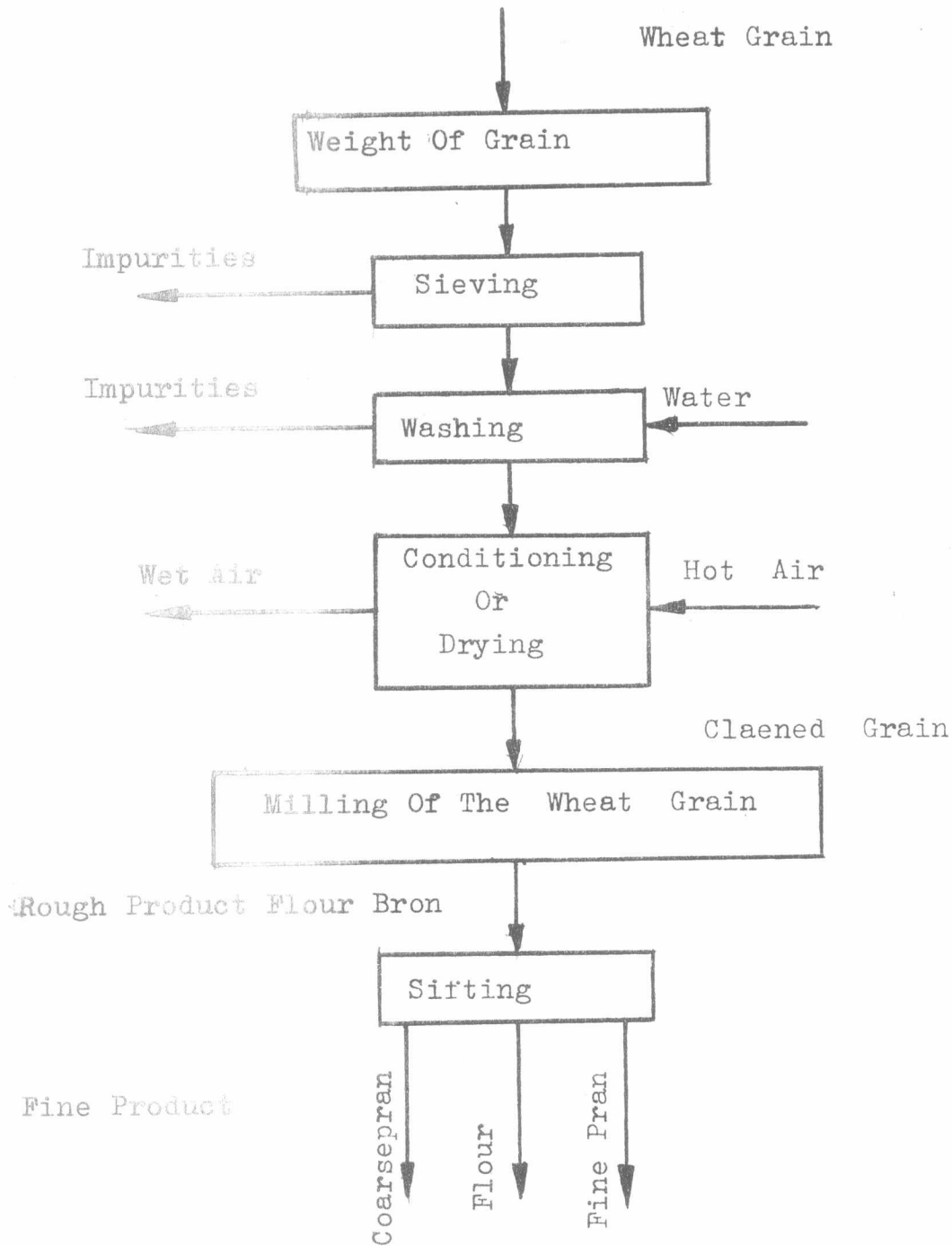

Fig. 1. Operation Sheat For Wheat Milling Using Metallic- Disc Mill .

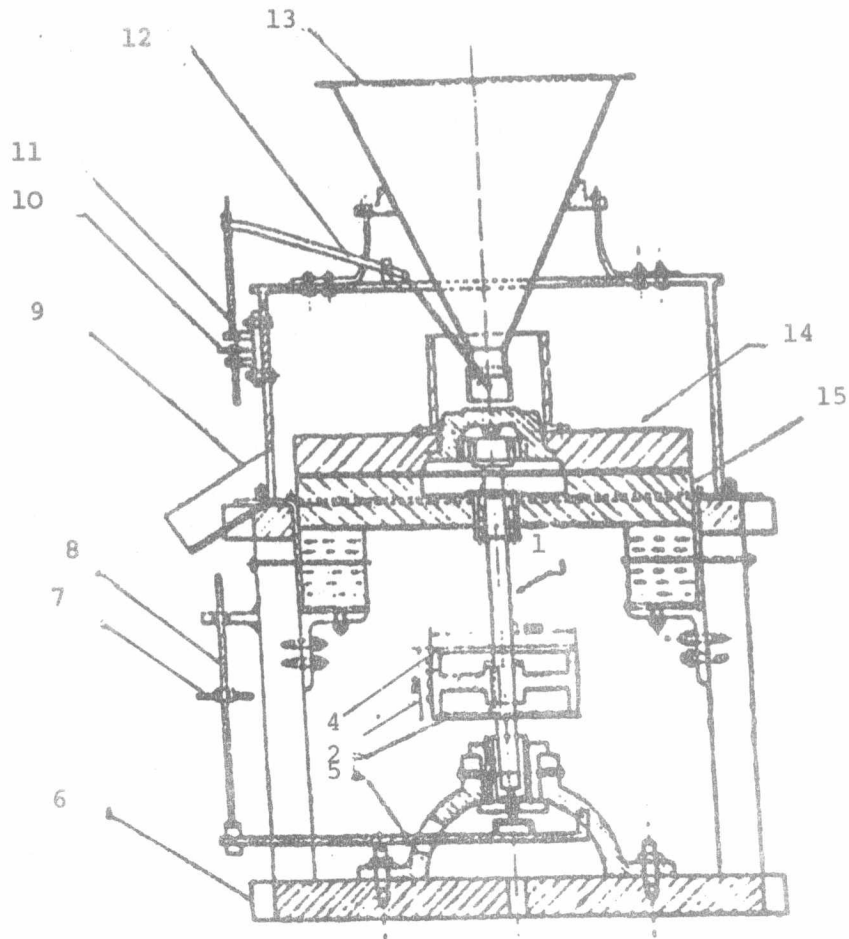

Fig. (2): SECTIONAL ELEVATION THROUGH THE METALLIC DISC MILL.

1	MAIN SHAFT
2	BELTS
3	BEARING
4	BULLEY
5	LEVER ADJUSTMENT CLEARANCE BETWEEN TWO DISCS
6	MILL BASE
7	MANUAL WHEEL
8	SCREW
9	FLOUR EXIT
10	MANUAL WHEEL
11	SCREW
12	LEVER ADJUSTMENT FEED GRAIN
13	BUCKET
14	ROTARY DISC
15	STATIONARY DISC

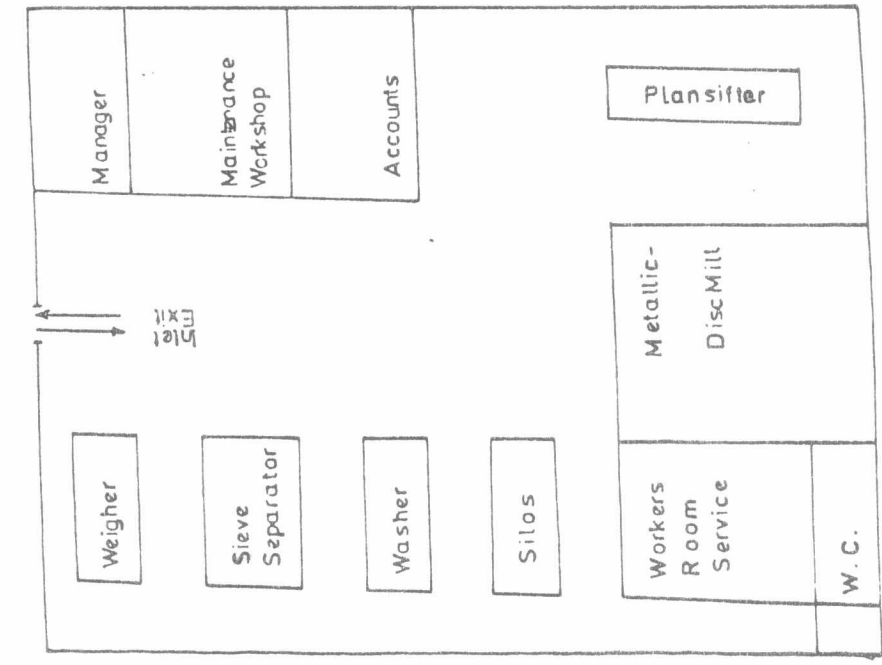

Fig. 4. U-Layout.

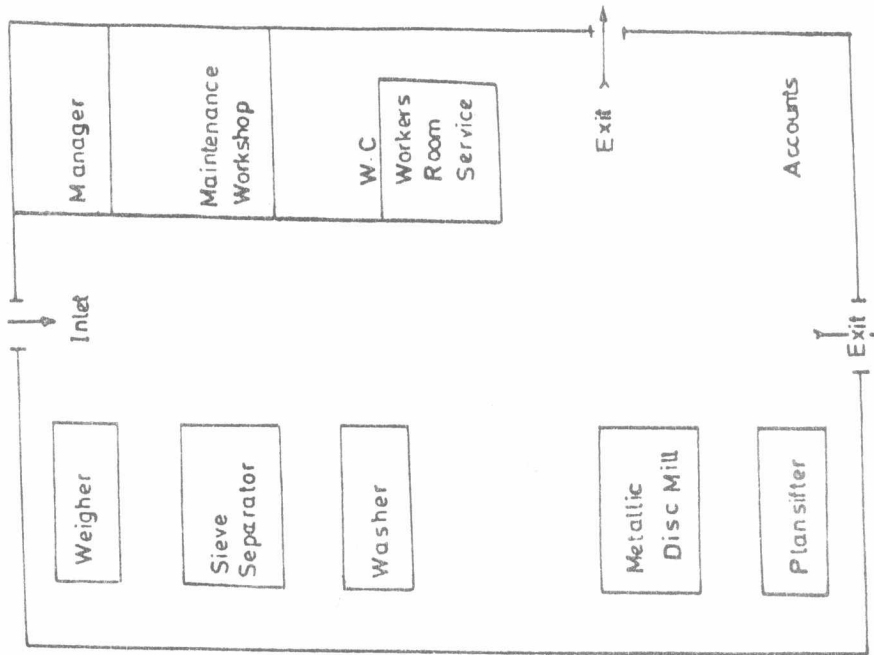

Fig. 3. I-Layout.

☒ Fixed Capital Requirement.

Basic factors		Present location						
		A	B	C	D	E	F	G
Land	LE							
Building	LE							
Equipment	LE							
Other Costs	LE							
Total	LE							

☒ Unit Cost of Production and Distribution

Materials	LE							
Direct labor	LE							
Transportation	LE							
Over head,								
- Insurance	LE							
- Power	LE							
- Depreciation	LE							
- Salaries	LE							
- Distribution	LE							
- Taxes	LE							
Total	LE							
Grand Total	LE							

Fig. 5 Comparison Chart; Capital investment and unit production and distribution of several locations.

