

Frequency of MEFV gene 12 mutations in a sample of Egyptian Patients with Familial Mediterranean Fever Disease In Relation To Disease Presentation

Hayam Nazif¹, Howaida Elgebaly¹, Ihab Imam², Osama Zaki³, Samer Elkhatay¹

¹Department of Medical Studies of Children, Institute of Postgraduate Childhood Studies, Ain Shams University.

²Department of pediatrics, Ain Shams University.

³Genetics Unit, Ain Shams University Hospital.

Abstract

Background: Familial Mediterranean fever (FMF) is an autosomal recessive hereditary disease that results from point mutations in the Mediterranean Fever (MEFV) gene on the short arm of chromosome 16. To date, more than 310 MEFV sequence variants have been reported including the most common M694V, V726A, M680I and M694I mutations.

Aim: To assess the distribution of MEFV gene mutations in a sample of Egyptian patients with FMF, to find certain genotype- phenotype correlation.

Patients& Methods: This was a cross- sectional study on one hundred fifty eight patients who were diagnosed primarily on clinical basis to have FMF then to be genetically tested for the most common 12 mutations in the MEFV gene in the Medical Genetics Unit; Paediatric Hospital; Ain Shams University, Cairo, Egypt.

Results: The study revealed that E148Q, M694I, V726A, M680I and M694V are the most common mutations of MEFV gene and that M691V, F479L and I692del mutations did not appear in our study population. Non- abdominal surgeries are almost 2.75 times more common than that of abdominal surgeries in the 5 common FMF mutations.

Conclusion: FMF in our study population did show great diversity in terms of age of onset, presentation, severity and response to treatment. This could be attributed to the heterogeneity of the disease; multiplicity of the mutations and that every mutation could present as heterozygous, homozygous and compound heterozygous.

Keywords: Familial Mediterranean fever, MEFV Gene and Colchicine.

تواتر ١٢ طفرة في جين ام. اي. اف. في عينه من المرضى المصريين

الذين يعانون من حمى البحر الأبيض المتوسط وعلاقتهم بحدوث المرض

الخلفية: حمى البحر الأبيض المتوسط العائلية (اف. ام. اف) هو اضطراب يتميز بنوبات حادة متكررة من الحمى مصحوبة بألم في البطن، والتهاب المفاصل، والتهاب الغشاء البلوري. المضاعفات الأكثر حدة هي حدوث الداء النشواني الكلوي، والتي يمكن الوقاية منها من قبل العلاج بدواء الكولشيسين. (اف. ام. اف). هو مرض وراثي متنحي الصفة، ويحدث نتيجة لطفرات نقطة (بدائل واحدة) في جينات البحر المتوسط (ام. اي. اف. في) على الذراع القصير من الكروموسوم ١٦. حتى الآن، تم اكتشاف أكثر من ٣١٠ متغيرات تسلسل ام. اي. اف. في. وتقع معظمها في اكسون ١٠.

الهدف: أجرينا دراسة مستعرضة على مائة وثمانية وخمسون من مرضى الذين تم تشخيصهم على أساس السريرية أن يكون اف. ام. اف ثم أن يتم اختبارها وراثيا للطفرات الأكثر شيوعا ١٢ في جين ام. اي. اف. في وحدة الوراثة الطبية؛ مستشفى طب الأطفال. جامعة عين شمس. وكان الدراسة تضم ٧٩ من الذكور و ٧٩ من الإناث الذين تتراوح أعمارهم بين سنتين إلى ٢٠ عاما، وكان متوسط أعمارهم ٨ سنوات. وقد تعرض كل مريض لأخذ التاريخ الكامل، والفحص السريري والتحليل حيث تم سحب عينه دم من كل مريض اف. ام. اف لدراسة الوراثة (يغطي هذا الفحص ١٢ طفرات في جين (ام. اي. اف. في)).

النتائج: تم جمع النتائج وتحليلها إحصائيا على النحو التالي E148Q، M694I، V726A، M680I، M694V هي الطفرات الأكثر شيوعا من جينات (ام. اي. اف. في). وأن M691V، F479L، I692del طفرات لم تظهر في مجتمع الدراسة لدينا. جراحات غير البطن (استئصال اللوزتين/ اللحمية) هي تقريبا ٢,٧٥ مرة أكثر شيوعا من العمليات الجراحية في البطن (الفتق الإربي/ ناسور الشرج/ الفتق) تثبت الخصيتين/ البطن) في ٥ طفرات اف. ام. اف المشتركة.

الاستنتاجات: (اف. ام. اف) ليس مرض غير شائع لدى الشعب المصري، ولسوء الحظ هناك نقص في الوعي من الجانبين: الأطباء والمرضى، وفي مجتمع دراستنا أظهر (اف. ام. اف) تنوعا كبيرا من حيث سن بداية، العرض، شدة والاستجابة للعلاج. ويمكن أن يعزى ذلك إلى عدم تجانس المرض؛ وتعدد الطفرات، وأن كل طفرة يمكن أن تظهر مغاير الازيجوت، متماثل الازيجوت ومركب متغايرة.

Background:

Familial Mediterranean fever (FMF) is a disorder characterized by recurrent acute attacks of fever accompanied by abdominal pain, arthritis, and pleurisy. The most severe complication is the development of renal amyloidosis, which can be prevented by the daily and life-long administration of colchicine therapy (El shanti et.al., 2006).

FMF is an autosomal recessive hereditary disease and occurs as a result of point mutations (Single substitutions) in the Mediterranean Fever (MEFV) gene on the short arm of chromosome 16. This gene encodes a protein called pyrin, which is presumed that the mutated pyrin molecule is theoretically not able to suppress, and thus the inflammatory response develops (Cantarini et.al., 2012).

To date, more than 310 MEFV Fig. (1) sequence variants have been reported. Most are located in exon 10, including the most common M694V, V726A, M680I and M694I mutations. The wide clinical variability in FMF is partly explained by genetic heterogeneity (Shinar et.al., 2000).

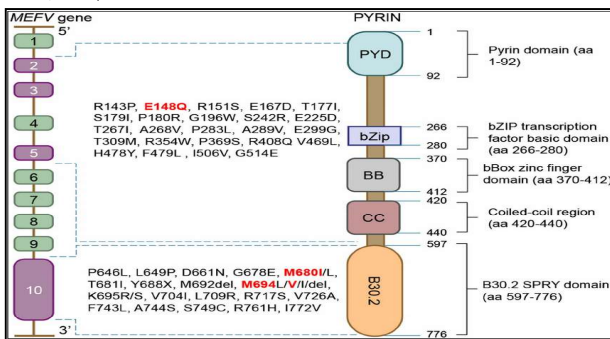

Figure (1) The MEFV gene mutation distribution and structure of the pyrin protein

Methods:

The Study is cross-sectional study on one hundred fifty eight patients who were diagnosed primarily on clinical basis to have FMF then to be genetically tested for the most common 12 mutations in the MEFV gene in the Medical Genetics Unit; Paediatric Hospital; Ain Shams University, Cairo, Egypt. They were 79 male and 79 female with an age ranging from 2 years to 20 years, their median age were 8 years.

Their inclusion criteria were an age of (2- 20) years old, cases manifesting clinical signs and symptoms and acceptance of enrolment. We have excluded children with concomitant diagnosis of another chronic disease or disorder unrelated to the familial Mediterranean fever itself and children that had negative gene testing for the FMF though they are manifesting symptoms and signs.

Patients were diagnosed clinically based on Tel- Hashomer criteria Fig. (2) which require at least two major criteria or one major and two minor criteria.

Major Criteria	Recurrent Febrile episode associated with peritonitis, pleuritis or synovitis
	Amyloidosis of AA-type without a predisposing disease
	Favorable response to daily colchicine administration
Minor Criteria	Recurrent Febrile episode
	Erysipelas-like erythema
	Positive history of faminal mediterranean fever in a first degree relative

Figure (2) The Tel- Hashomer criteria

Each and every patient was subjected to full history taking, clinical examination and A blood sample was withdrawn from each FMF patient for Molecular genetics study using DNA isolation followed by PCR amplification followed by hybridization (This assay covers 12 mutations in the MEFV gene: E148Q, P369S, F479L, M680I (G/ C), M680I (G/ A), I692deI, M694V, M691V, K695R, V726A, A744S, R761H (FMF strip assay Vienna lab labordiagnostika GmbH, Vienna, Austria)

Statistical Analysis:

Chi- square test to study the association between each 2 variables or comparison between 2 independent groups. Logistic Multi- Regression analysis was used to search for a panel (independent parameters) that can predict the target parameter (dependent variable) (SPSS 2004 Version 12).

Results:

The study group showed the minimum age of FMF patient is two years old, meanwhile the maximum is twenty years with a mean age of 8.2± 3.9 years. The mean duration level of the disease is 4.45 years. There was no sex difference among FMF study population and the ratio is M: F; 1: 1. There was no sex predilection among all mutations except M680I which showed male preponderance 1.8: 1.

E148Q, M694I, V726A, M680I and M694V are the most common mutations of MEFV gene and that M691V, F479L and I692deI mutations did not appear in our study population. The most common presenting symptoms among FMF patients were fever, abdominal pain and Restlessness/ Anxiety/ Irritability (89.8%, 88.6% and 86% respectively). Meanwhile, erysipelas like erythema was the least common (1.2%) Table (1).

Table (1) Percentage frequency of all symptoms and phenotypes among FMF study population

Phenotypes/Symptoms	Total	Percentage%
Fever	142	89.8%
Abdominal Pain	140	88.6%
Restlessness/ Anxiety/ Irritability	136	86%
Arthralgia	81	51.2%
Weakness/ Fatigue	76	48%
Chest Pain	49	31%
Diarrhoea	40	25.3%
Vomiting	33	20.8%
Myalgia	23	14.5%
Erysipelas Like Erythema	2	1.2%
Total Patients	158	100%

Non- abdominal surgeries (Tonsillectomy/ Adenotonsillectomy) are almost 2.75 times more common than that of abdominal surgeries (Inguinal hernia/ anal fistula/ hernias/ Orchidopexy/ laparotomy) in the 5 common FMF mutations Fig. (3).

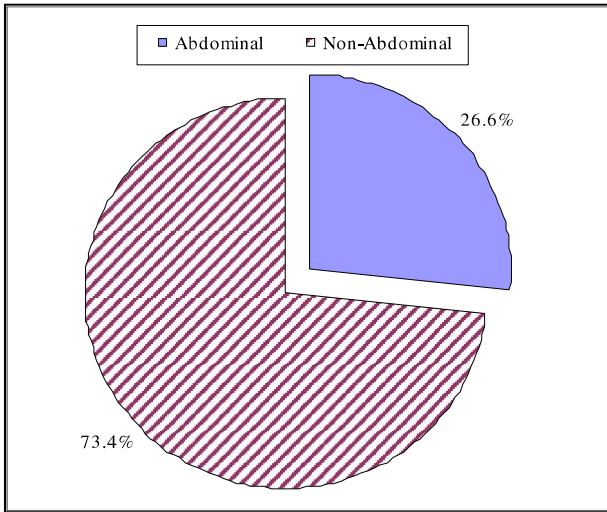

Figure (3) Percentage frequency of abdominal and non- abdominal surgeries done among most common FMF mutations

The most sensitive independent variables (symptomatology) that predict the dependent variable (mutations) are; vomiting for V726A, Weakness, Fatigue & Myalgia for M680I, Arthralgia & Vomiting for E148Q and Vomiting for M694I. The most sensitive independent variables (symptomatology) that predict the dependent variable (zygosity) are; FH & Arthralgia for Compound heterozygous, FH & Vomiting for Heterozygous and Arthralgia & Abdominal Pain for Homozygous Table (2).

Table (2) Logistic Multi- Regression analysis test for the commonest FMF gene mutations (dependent variable) Vs symptomatology (independent variables).

Dependent Variable: V726a	t	p	Sig.	F- Ratio	p	Sig.
(Constant)	2.907	0.004	HS			
Vomiting	- 2.518	0.013	S			
				3.671	0.028	S
Dependent Variable: M680i	t	p	Sig.	F- Ratio	p	Sig.
(Constant)	5.827	0	HS			
Weakness, Fatigue	- 2.467	0.015	S			
Maylgia	2.305	0.023	S			
				5.404	0.005	HS
Dependent Variable: E148q	t	p	Sig.	F- Ratio	p	Sig.
(Constant)	3.136	0.002	HS			
Arthralgia	2.924	0.004	HS			
Vomiting	2.209	0.029	S			
				8.032	0	HS
Dependent Variable: M694i	t	p	Sig.	F- Ratio	p	Sig.
(Constant)	9.579	0	HS			
Vomiting	- 3.045	0.003	HS			
				7.421	0.001	HS

Discussion:

Our study population showed that there is no sex difference among our patients; 50% males and 50% females with a male to female ratio of 1: 1. This finding coincides with the results of Salah et.al., (2012) who reported a male to female ratio about 1: 1.03.

Regarding the age distribution, the mean age of population was 8.2± 3.9 years (range, 2- 20 years), this finding accord with Salah et.al., (2012) who reported a mean age of 9.5± 3.6 years (range, 2- 16 years). In the meantime, the mean age of onset was 4.13± 2.11 years (range from 1 year to 14 years of age).

Our current study showed that there was a positive family History in 17% in the entire study group and ranging from 11% to 20% among different mutations but without significant difference. Our results go with Ozturk et.al (2009) and Salah et.al. (2012) whom reported 22.5% & 26.2% respectively and is almost half of that reported by Kilic et.al (2015) and Mneimneh et.al (2016) that found in their studies (44.6% & 40.8% respectively).

Regarding the percentage frequency of different mutations; the study revealed that the most common mutations were E148Q (28%), M694I (26%), V726A (14%), M680I (13%) and M694V (8%) in our study population. Similarly, a study by El Gezery et.al., (2010) revealed that the most common alleles were M694I (34%) followed by E148Q (22.7%), V726A (15.6%), M680I (12.1%) and M694V (7.8%). This variation could be explained by the different ethnic groups among the different studies.

We have found that FMF patients could present in many different ways but the most common reported symptoms were Fever (89.8%), abdominal pain (88.6%), and Restlessness/ Anxiety/ Irritability (86%). Then come in succession; Arthralgia (51.2%) Weakness & Fatigue (48%). Other recorded symptomatology were chest pain (31%), Diarrhea (25.3%), Vomiting (20.8%), Myalgia (14.5%) and Erysipelas like erythema (1.2%).

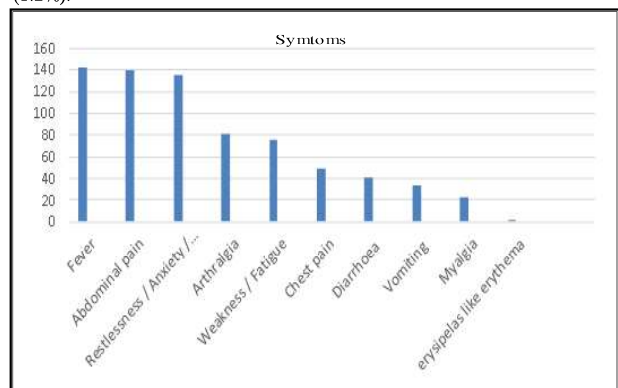

Figure (4) Bar Chart for the percentage frequency of all symptoms and phenotypes among FMF study population

These results are in agreement with Mneimneh et.al., (2016) who reported almost similar percentages to our data; Abdominal pain (84.7%), Fever (78.2%), Arthralgia (43%), Chest pain (30.5%), Vomiting (15.3%), Diarrhea (6.2%) and Erysipelas like rash (3.3%). This discrepancy could be justified by the different frequencies of gene mutations among ethnic groups enrolled from the different studies. This difference necessitates a larger scale study of Egyptian FMF patients to be representative of the large Egyptian population.

We have tried to correlate each mutation (genotype) and phenotyping; to pick up the frequent phenotypes and to compare them with other mutations and also compare them with other studies. For example; when speaking about mutation E148Q, our data coincide with Ozturk et.al., (2009) who mentioned that abdominal pain and arthralgia are the most frequent symptoms in this mutation itself and if compared to other mutations.

We also found that heterozygous type (44%) is the most common

among other types followed by compound heterozygous (38%) followed by homozygous (18%). These findings were in agreement with Mneimneh et.al., (2016).

Looking into the symptomatology of the different mutations, the E148Q mutation which is the most frequent one in our study population showed that abdominal pain (87%) and combined symptomatology (87%) are the most common then comes in succession fever (85%) and arthralgia (74%), the least common was the chest pain (28%). These findings coincide with the study done by Mneimneh et.al., (2016)

In regard to of mutations V726A, M694I& M694V they present almost similarly by fever and abdominal pain in more than 90% of the study population. These findings were supported by Ozturk et.al., (2009)& Mneimneh et.al., (2016) Table (3).

Table (3) Percentage frequency of Clinical phenotypes among the common FMF mutations

Phenotypes (N& %)	mutations					Chi- Square Tests	
	E148q (N= 46)	V726a (N= 43)	M694i (N= 41)	M680i (N= 35)	M694v (N= 22)	Value	P
Fever	39 (85%)	40 (93%)	56 (92%)	32 (91%)	21 (95%)	25.43	0.0625
Abdominal Pain	40 (87%)	39 (91%)	56 (92%)	27 (77%)	21 (95%)		
Chest Pain	13 (28%)	13 (30%)	23 (38%)	13 (37%)	6 (27%)		
Arthralgia	34 (74%)	20 (47%)	22 (36%)	17 (49%)	7 (32%)		
Combined	40 (87%)	19 (44%)	18 (44%)	27 (77%)	11 (50%)		

By using the Multiple Logistic Regression analysis for the commonest FMF gene mutations (dependent variable) Vs symptomatology (independent variables), we identified that the most sensitive (statistically significant) independent variables (symptomatology) that predict the dependent variable (mutations) are; Vomiting for V726A; Weakness, Fatigue& Myalgia for M680I; Arthralgia& Vomiting for E148Q and Vomiting for M694I.

Also By using the same test for the different Zygosity (dependent variable) Vs symptomatology (independent variables), it revealed that the most sensitive (statistically significant) independent variables (symptomatology) that predict the dependent variable (zygosity) are; family history& arthralgia for Compound heterozygous; family history& Vomiting for Heterozygous and Arthralgia& Abdominal Pain for Homozygous.

These statistical findings are hardly explained or implemented on clinical basis because of the non- specificity of the independent variables (symptomatology) in relation to dependent variables whether mutations or zygosity.

Conclusion:

FMF is not an uncommon disease in the Egyptian population and unfortunately there is lack of awareness from the two sides, doctors and patients. FMF in our study population did show great diversity in terms of age of onset, presentation, severity and response to treatment. This could be attributed to the heterogeneity of the disease; multiplicity of the mutations and that every mutation could present as heterozygous, homozygous and compound heterozygous. Periodicity is the mainstay for diagnosing FMF even in mono- symptomatic presentation.

References:

(Frequency Of MEFV Gene 12 Mutations ...)

- Al- Haggag M, Yahia S, Abdel- Hady D, Al- Saied A, Al- Kenawy R, Abo- ElKasem R. Phenotype- genotype updates from Familial Mediterranean Fever database registry of Mansoura University Children hospital, Mansoura, Egypt. **Indian Journal of Human Genetics** January- March 2014 Volume 20 Issue 1
- Cantarini L, Rigante D, Brizi MG, Lucherini OM, Sebastiani GD, Vitale A. Clinical and biochemical and marks in systemic autoinflammatory diseases. **Ann Med** 2012; 44: 664- 73.
- El Gezery DA, AbouZeid AA, Hashad DI, ElSayegh HK. MEFV gene mutations in Egyptian patients with Familial Mediterranean Fever. **Genet Test Mol Biomarkers** 2010; 14:263- 8.
- El- Shanti H, Majeed HA, El- Khateeb M. Familial Mediterranean fever in Arabs. **Lancet** 2006; 367: 1016- 24.
- Kasifoglu T, Cansu DU, Korkmaz C. Frequency of abdominal surgery in patients with Familial Mediterranean Fever. **Intern Med** 2009; 48:523- 6.
- Kilic A., Varkal M., Durmus M. and Yildiz I. Relationship between clinical findings and genetic mutations in patients with familial mediterranean fever. **Pediatric rheumatology** 2015; 13:59
- Mneimneh, S., Naous, A., Naja, Z., Naja, Z., Naja, A. S., Megarbane, A. and Rajab, M. Familial Mediterranean Fever: Clinical and Genetic Characteristics among Lebanese Pediatric Population. **Open Journal of Rheumatology and Autoimmune Diseases**, 2016; 6, 63- 73.
- Öztürk A, Elbosky E, Elsayed SM, Alhodhod M, Akar N. Mutational analysis of the MEFV gene in Egyptian patients with Familial Mediterranean Fever. **Turk. J. Med. Sci.** 2009; 39(2): 229- 34.
- Portincasa P., Scaccianoce G. and Palasciano G., Familial Mediterranean Fever: a fascinating model of inherited auto inflammatory disorder. **Eur J Clin Invest** 2013; 43 (12): 1314- 1327.
- Settin A, El Baz R, Abd Rasool M, El Khalegy H, El Sayed O, El Bendary M. Clinical and molecular diagnosis of Familial Mediterranean Fever in Egyptian children. **J. Gastrointest Liver Dis.** 2007, 16(2): 141- 5
- Shinar Y, Livneh A, Langevitz P, Zaks N, AksentijevichI, Koziol DE. Genotype- phenotype assessment of common genotypes among patientswith Familial Mediterranean Fever. **J Rheumatol** 2000; 27: 1703- 7.
- Tunca M, Akar S, Onen F, Ozdogan H, Kasapcopur O, Yalcinkaya F. Familial Mediterranean Fever (FMF) in Turkey. Results of a nationwide multicenter study. **Medicine (Baltimore)** 2005; 84(1): 1- 11.
- Zeinab A. El- Sayed, Continuous Medical Education, Familial Mediterranean Fever. **Egypt J Pediatr Allergy Immunol** 2004; 2(2): 111-113.