



## Small Cell Network Densification using a New Space-Time Block Code (STBC)

Adel Khaled<sup>1</sup>, Saly Hassaneen<sup>2</sup>, Salah Elagooz<sup>3</sup>, Heba Soliman<sup>4</sup>

### Abstract.

With the exponential increase in cellphone internet traffic consumed by new generations of wireless devices, cellular networks face a critical challenge to meet this vast demand of network capacity. As well, the demand for higher data rates and the ever-increasing number of wireless devices led to rapid increase in power consumption and cost of operation of cellular networks. One potential solution to address these issues is to overlay small cell access points with macro cell base stations (BS) as a mean to provide higher network capacity and better network coverage. The major problem, which met the small cells densification, is the strong interference power from the adjacent macro cells. Hence, this paper proposes a new space-time block code, which can be used by outdoor small cell BSs. The small cells are equipped with two antennas and transmit three symbols via three time slots. The new code can cancel the overall interference that affects the small cell data transmission. The proposed code will increase the data rate of the overall network without sharing overhead data between the macro cells and the small cells, permitting the network backhaul to be free for data transmission only.

### 1. INTRODUCTION

Wireless communications are one of the most widely deployed technologies. New phone applications that essentially use the internet, where personal uses or even military and commercial uses, appear daily and increase the demand for higher data rates. Also, highly efficient quality of service (QoS) must also be considered [1].

The network throughput (bits/sec) should be extended by 1000 fold over 10-15 years to meet this demand. In contrast, the transmission power should be decreased to satisfy the requirements of the green networks, where the energy-related pollution is becoming major societal and economic concerns [2]. Subsequently, wireless networks with high data rates, taking into consideration the emitted power of the wireless devices leads us to search for new technologies to meet these aspirations.

There is a considerable agreement that these requirements will be met only by network densification. One of the network densification technologies is the massive MIMO (Multiple-Input Multiple-output) Antennas technique. Hundreds of antennas are equipped to the macro base station, based on precoding techniques; the desired signal will reach the user's space point in a constructive manner. All users can be served at the same time/frequency resources [3]. The massive MIMO base station can serve tens of users at the same time, taking into account that the number of antennas should be greater than the users by 10 folds [4,5].

The ordinary noise and the intra-cell interference would be disappeared completely when a huge number of antennas are equipped with the base station, also the small-scale fading can be averaged using simple matched filters [4]. The emitted power from the base station and the user equipment will be inversely proportional with the number of BS equipped antennas which saves the user's battery, this is also an important advantage of massive MIMO networks [6,7].

Time-division duplex (TDD) mode is considered as the heart of the Massive MIMO systems, where the data transmission through the uplink and downlink takes place with the same channel statistics, same frequency resource but separated in time [8].

The second technology is to use the small cells densification technique, where a dense number of low-cost, low-power base stations spread over the network in an irregular manner. Bringing the user as close as possible to the base station will increase the networks area throughput (bits/s/Km<sup>2</sup>) and decrease the transmitted power [2].

The small cells will operate side by side with the macro base stations at the same operation bands and time to exploit all the network resources. Low mobility users can be served by the small cells, leaving the macro cells to serve high mobility users [9,10]. The two technologies can work together using two manners. Working separately, each base station from the small cells or the macro BSs serve its user without any listening to the other type. The second one is the cooperation manner, where, the channel's statistics and any information about the users can be shared using the backhaul connections [11,12].

Therefore, we can list the important features of the small cells densification technique as follows:

- Higher area network throughput: a large number of users can be served by the small cells at a given macro BS coverage area using the same

<sup>1</sup>Electrical Engineering Department, Faculty of Engineering, Suez University, Suez, Egypt, E-mail: eng\_adelkhaled@suezuniv.edu.eg

<sup>2,4</sup>Electrical Engineering Department, Faculty of Engineering, Port Said University, Port Said, Egypt.

<sup>3</sup>Electronics and Comm. Department, Faculty of Engineering, El-Shorouk University, El-Shorouk, Egypt, s.elagooz@sha.edu.eg

radio resources, allowing for a greater area spectral efficiency (i.e., total number of active users per Hz per unit area).

- Low power consumption: the small distance between the user equipment and the small cell will decrease the emitted power from the user's device and the cell.
- Macro Base station offload: occasionally, some places turn into crowded areas, therefore, we can use services of the small cells to offload the Macro BS.
- Cost enhancement: cell-site planning engineers usually perform an extensive site survey and network planning process to deploy a new expensive macro cell BSs. On the other hand, small cells can be easily inserted and work easily with an existing network allowing a cost-effective and scalable network evolution [13].

The most common type of small cells is the femtocells. It introduces additional layer to the heterogeneous networks working with the macro cells, with high QoS, small and focused area. Femtocells can be deployed in various environments, such as residential, public or enterprise. Originally, it is directed to home users and small office users to cover one user or a group of users via the backhaul connectivity, typically across the Asymmetric Digital Subscriber Line ADSL of the user itself or the fiber connection [14].

The current generations of the femtocells (small cells) equipped with single antenna as the IP access E16, E24 and E32 nano3G or multiple antennas as IP access s61 nanoLTE [15]. Using multiple antennas help to overcome the interference with the surrounding transceivers whether they are small cells or macro cells. MIMO spatial multiplexing and beamforming became dependable techniques in the wireless standards such as IEEE 802.11n WiFi, IEEE 802.16 WiMAX, 3GPP HSPA and LTE/LTE A.

The cross-interference between the small cells and the macro cells is the main problem facing the network's engineers. The small cells could not be sited outdoors next to the macro cell. It should be sited far away from the macro cell or be hidden at buildings to guarantee very low interference from the macro cells. What if we plan to site the small cells at the streets, malls and outdoor places?

The proposed transmission scheme deals with the outdoor small cells. It proposes a novel code, which cancels the overall interference facing the small cell's users.

The rest of this paper is organized as follows. Section II presents the space diversity and discusses the conventional Alamouti code in the presence of interference. The system model and the new space-time block scheme to minimize the aggregate interference experienced by SCs are presented in section III. Finally, Section IV presents our Calculation results and Section V concludes the paper.

## 2. SPACE DIVERSITY

Alamouti proposed a Space-Time Block Code (STBC) matrix used to generate a diversity of order two using two antennas at the transmitter and one antenna at the receiver [16]. No bandwidth expansion is expected since the redundancy is applied in space across multiple antennas.

Two symbols are transmitted via two transmission time slots using two antennas in a systematic manner to achieve a rate equal to one since the rate is equal to the number of antennas divided by the number of time slots. At the first time slot, the first and second antennas send  $x_1$  and  $x_2$  symbols respectively to the receiver's antenna. At the second time slot, the first antenna sends  $-x_2^*$  and the second antenna sends  $x_1^*$  to the receiver's antenna as illustrated in table 1.

Tab. 1. Conventional Alamouti code [16].

	Antenna 1	Antenna 2
Slot time t1	$x_1$	$x_2$
Slot time t2	$-x_2^*$	$x_1^*$

First, we need to check the performance of the Alamouti code in the presence of surroundings' interference. Suppose a massive macro BS with M antennas interferes with a small cell with two antennas that uses the conventional Alamouti code. The channel between the small cell's transmitter and the small cell's receiver is assumed to be time invariant during the transmission process. So,

$$h_1(t_1) = h_1(t_2) \quad (1)$$

$$h_2(t_1) = h_2(t_2) \quad (2)$$

,where  $h_1$  and  $h_2$  are the channels between the small cell antennas and the small cell user (SCU). The received signal at the SCU with one antenna will be as follow

$$z_1(t_1) = h_1x_1 + h_2x_2 + \mathbf{H}_m \boldsymbol{\varphi} + n_1 \quad (3)$$

$$z_2(t_2) = -h_1x_2^* + h_2x_1^* + \mathbf{H}_m \boldsymbol{\varphi} + n_2 \quad (4)$$

,where  $\mathbf{H}_m \in \mathbb{C}^M$  is the channel vector between the massive macrocell antennas and the SCU,  $\boldsymbol{\varphi}$  is the transmitted symbols from the massive macrocell with  $E\{|\boldsymbol{\varphi}|^2\} = 1$ ,  $n_1$  and  $n_2$  are the additive white Gaussian noise at the SCU antennas.

The estimated symbols at the receiver combiner (SCU) antenna will be decoded as [13]

$$\hat{x}_1 = h_1^*z_1 + h_2z_2^* \quad (5)$$

$$\hat{x}_2 = h_2^*z_1 - h_1z_2^* \quad (6)$$

Then,

$$\hat{x}_1 = ((\|h_1\|^2 + \|h_2\|^2)x_1 + h_1^*n_1 + h_2n_2^* + h_1^*\mathbf{H}_m \boldsymbol{\varphi} + h_2\mathbf{H}_m^* \boldsymbol{\varphi} \quad (7)$$

$$\hat{x}_2 = (\|h_1\|^2 + \|h_2\|^2)x_2 - h_1n_2^* + h_2^*n_1 + h_2^*H_m\varphi - h_1H_m^*\varphi \quad (8)$$

The signal to interference and noise ratio of Alamouti code will be [9], [2]

$$SINR = \frac{\|h_1\|^2 + \|h_2\|^2}{|h_1^*H_m|^2 + |h_2H_m^*|^2 + var(n)} \quad (9)$$

with the noise variance of  $var(n)$ .

The interference power from the massive macro cell controls the amount of SINR at the SCU. This interference is expected to destroy the connection between the small cell and its SCU. Increasing the emitted power from the small cell will interfere destructively with the downlink connection between the massive macro cell and its users also.

### 3. SYSTEM MODEL AND PROPOSED TRANSMISSION SCHEME

#### 3.1 System Model

Suppose one small cell BS equipped with two transmit/receive antennas. The small cell user is equipped with one antenna. The small cell works without any cooperation with one massive macro cell BS with M antennas serving K macro cell users (MCU), as shown in figure 1.

The channel between the small cell (SC) and the small cell user (SCU) is  $h$ . The channel is assumed to be independent and identically distributed (i.i.d.), zero-mean, circularly-symmetric complex Gaussian Rayleigh fading channel. The downlink transmission from the small cell BS to its SCU may interfere with the downlink signal from the macro cell BS or from the neighboring MCU's uplink or from both..

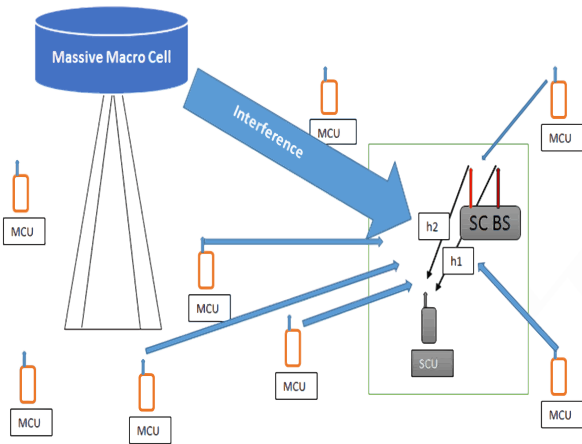

Fig. 1. One small cell with two antennas serves one small cell user with one antenna overlaid with the one massive macro cell equipped with M antennas

Hence, the aggregate interference from the macro cell BS and its users at the SCU's antennas can be expressed as follows [9]

$$\sum I = \sum_{m=1}^M \sqrt{p_d} g_m \varphi + \sum_{k=1}^K \sqrt{p_{uk}} g_k \phi \quad (10)$$

,where  $p_d$  and  $p_{uk}$  are the downlink power from the macro BS and the uplink power from MCUs respectively,  $g_m$  is the channel between the  $m$ th antenna of the macro BS and our SCU antenna,  $g_k$  is the channel between the  $k$ th MCU and the small cell antenna,  $\varphi$  and  $\phi$  are the transmitted symbols from the macro BS and the MCU respectively.

#### 3.2 Proposed Transmission Scheme

To mitigate the cross-interference from the macro BS to the SCU, we propose a new STBC matrix  $X_{new-stbc}$ , which is used at the SC BSs, shown in figure 2. It is organized as follows

$$X_{new-STBC} = \begin{pmatrix} x_1 & x_2 \\ -x_1 & -x_2 \\ -x_2^* & x_1^* \end{pmatrix} \quad (11)$$

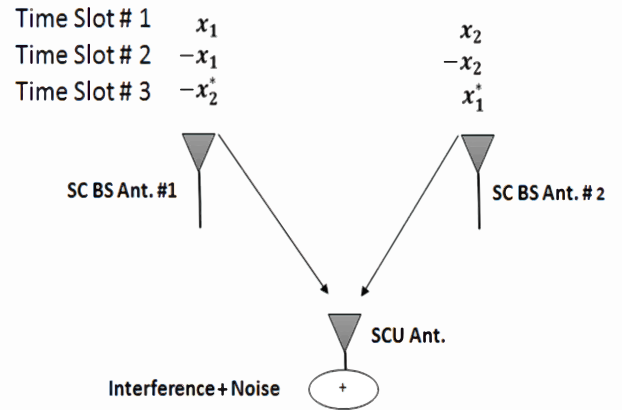

Fig. 2. The new transmission scheme for a SC BS equipped with two transmit antennas and a SCU equipped with one antenna.

At time slot  $t_1$ , the first and second antennas will transmit  $x_1$  and  $x_2$  symbols respectively as shown in figure 2. Then, the received signal  $y_1$  at the SCU antenna will be

$$y_1 = h_1x_1 + h_2x_2 + \sum I + n_1 \quad (12)$$

,where  $h_1$  and  $h_2$  are the channels between the SC antennas 1 and 2 respectively and the SCU antenna,  $\sum I$  is the interference from the macro BS and its users which is assumed to be the same during time slots  $t_1$ ,  $t_2$  and  $t_3$  and  $n_1$  is the complex noise during time slot  $t_1$ .

At time slot  $t_2$ , the symbols  $-x_1$  and  $-x_2$  will be transmitted from SC antennas 1 and 2 respectively.

$$y_2 = -h_1x_1 - h_2x_2 + \sum I + n_2 \quad (13)$$

Where  $n_2$  is the complex noise during time slot  $t_2$ . By adding equations (12) and (13)

$$y_1 + y_2 = 2 \sum I + n_1 + n_2 \quad (14)$$

Dividing by 2

$$int = \sum I + \frac{n_1 + n_2}{2} \quad (15)$$

At time slot  $t_3$ , the received signal  $y_3$  will be

$$y_3 = -h_1 x_2^* + h_2 x_1^* + \sum I + n_3 \quad (16)$$

, then by subtracting (15) from (12) and (16)

$$y_a = y_1 - int = h_1 x_1 + h_2 x_2 + n_1 - \frac{n_1 + n_2}{2} \quad (17)$$

$$y_b = y_3 - int = -h_1 x_2^* + h_2 x_1^* + n_3 - \frac{n_1 + n_2}{2} \quad (18)$$

Using Alamouti detection rules, the estimated received symbols will be:

$$\hat{x}_1 = h_1^* y_a + h_2 y_b^* \quad (19)$$

$$\hat{x}_2 = h_2^* y_a - h_1 y_b^* \quad (20)$$

The resulting estimated symbols will be

$$\hat{x}_1 = \frac{(\|h_1\|^2 + \|h_2\|^2)x_1 + h_1^* n_1 + h_2 n_3^*}{2} - \frac{h_1^*(n_1 + n_2)}{2} - \frac{h_2(n_1 + n_2)^*}{2} \quad (21)$$

$$\hat{x}_2 = \frac{(\|h_1\|^2 + \|h_2\|^2)x_2 + h_2^* n_1 - h_1 n_3^*}{2} - \frac{h_2^*(n_1 + n_2)}{2} + \frac{h_1(n_1 + n_2)^*}{2} \quad (22)$$

The proposed model assumes that the channel between the small cell and the SCU remains constant during the transmission process, this assumption is also valid with the cross-interference between the tiers. As mentioned in [2] and [17], the channel between the macro BS and the MCUs is assumed to remain constant during the whole frame time, about 200-400 symbols time. The proposed model assumes orthogonal frequency-division multiplexing (OFDM) operation, where the frequency-selective fading channel is divided into flat-fading sub-bands. The coherence time for the OFDM sub-band is  $t_c$ . The frame time  $S$  is equal to coherence time of the sub-band  $t_c$  multiplied by the channel's coherence bandwidth  $w_c$  [2].

$$S = t_c \times w_c \quad (23)$$

Also, a power control policy is assumed where the power of the signal  $\varphi$  and  $\phi$  are assumed to be unity,  $E\{|\varphi|^2\} = E\{|\phi|^2\} = 1$ . The downlink power  $p_d$  and the uplink power  $p_{uk}$  of the macro BSs and its users are defined based on the channel statistics. Hence, the transmission power of the massive MIMO networks remains constant from 200 to 400 time slots. So, the cross-interference between the tiers could be assumed constant during the transmission process. As a result, the transmission process at the small cell uses the same interference statistics about 200 to 400 time slots,

which ensures easy implementation of the new STB Code [2],[4].

## 4. CALCULATION RESULTS

Consider a massive MIMO macrocell with radius  $R=100 \sim 1000$  meter, and equipped with 50 antennas serves 10 MCUs. The choose of 1000 m and 100 m as a case study follow the small cell forum case study[18]. The small cell serves one user per a time and share the same available bandwidth with the macrocell. We consider three different network setups: outdoor SC with 100-meter distance from the massive macrocell, the second and the third setups are indoor SC with 100 and 1000-meter distance from the macrocell respectively. The link budget for the macrocell is defined using the ITU P.1411 model [19]. We use the indoor propagation model ITU-R P.1238 [20], assuming a residential building and same floor operation. The used network parameters are listed in table 2.

Table. 2. Network parameters

Macro cell Radius	R= 1000 m
Number of MCUs	K=10
macro cell power	P <sub>mass</sub> =43 dBm
Small cell power	P <sub>sc</sub> =10 dBm
Small cell radius	R <sub>sc</sub> = 0~ 50 m
Path loss	pl <sub>m</sub> =20*log <sub>10</sub> (f)+N*log <sub>10</sub> (d)+Pf(n)-28*; *f is frequency in MHz, N=distance power loss coefficient, d=distance from macro cell to SCU, n= number of floors, Pf(n)= the floor loss penetration factor. Wall penetration loss=12 dB, Vertical wall

Figure 3 compares the bit error rate of the mentioned schemes in the indoor and outdoor scenarios. The conventional Alamouti code is used at the indoor SCs. The new scheme is used at the outdoor SC with two transmit antennas and a single receive antenna. The outdoor SC with the new STBC scheme achieves the same bit error rate performance of the indoor SC located at 1 km from the macro cell, which ensures a very low interference level. Using the same network resources, the new STBC gives a BER of  $10^{-4}$  at Eb/No of 9 dB. The proposed STBC scheme was compared with the conventional Alamouti code, which achieves the same slope obtained by the original Alamouti code. In the case of the indoor SC located at 1 km, the dominant interference will be the additive Gaussian noise. By using the new STBC scheme, the dominant interference power also comes from the additive Gaussian noise as shown in figure 3 and equations 21 and 22.

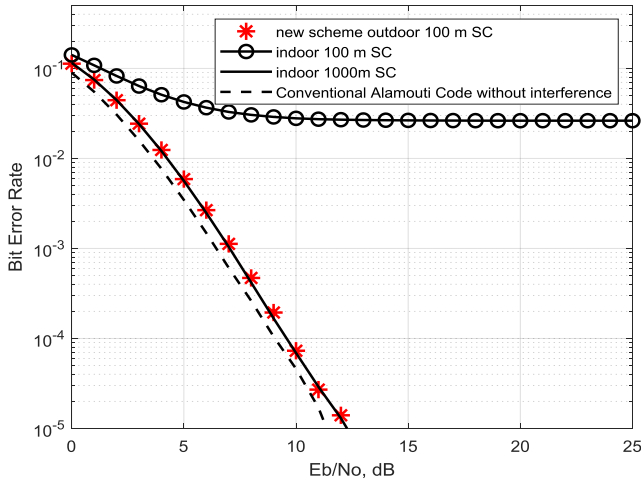

Figure 3: Small cell user bit error rate for the new scheme

Figure 4 compares the throughput of the outdoor SC using the new STBC and the indoor SCs using conventional Alamouti code. The slope of throughput of our outdoor new STBC small cell with 100-meter from the macro cell equal to the slope of throughput of the indoor SC with 1000-meter from macro cell. When the SCU is 5 meters away from the SCs, both the proposed outdoor STBC and the indoor 1 Km SC achieve about 50 Mbps. In the same conditions, the 100 m SC can only achieve 0.0002 Mbps.

If the macro cells do not use any precoding techniques, increasing the number of the massive macro cell antennas increases the number of interference links, which consequently decreases the throughput of the indoor 100 m SC, as shown in figure 5. Using the new STBC scheme with the outdoor SC, the throughput remains constant even if the number of the macro cell service antennas increases, and the macro cell does not use any precoding techniques.

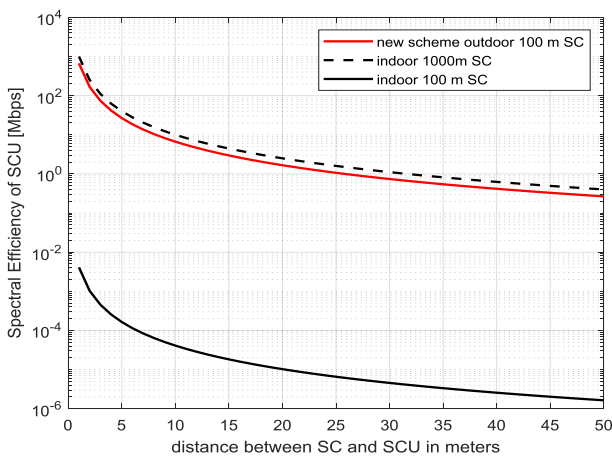

Figure 4: Throughput of a small cell user

However the data rate of the small cells will be decreased by 1/3 of its original value, where the data is sent using three-time slots via two antennas. So, the data rate  $R=2/3$ , but the aggregate throughput of the small cell will be significantly enhanced as shown in the calculation

results. The proposed scheme will decrease the computational complexity of the hardware, making fabrication of small cells easier. The power consumed by the small cells and its users will decrease also when using the new matrix code.

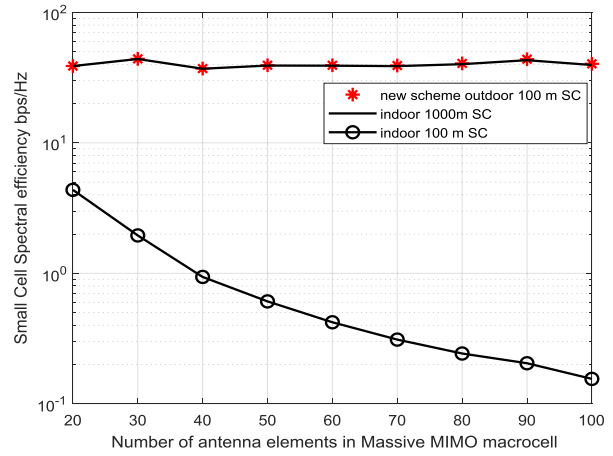

Figure 5: The spectral efficiency of the small cell BS overlaid with one massive MIMO antennas serves 10 users

## 5. CONCLUSION

We have considered a new space-time block code based two-tier network architecture which incorporates the advantageous features of a massive MIMO macro BS overlaid with small cells. This new scheme used to reduce the interference to the SC-tier. Our calculation results indicate that the proposed scheme can significantly minimize the aggregate cross-tier interference experienced by SCs without any macro performance loss. Consequently, we can increase the number of the small cells BS to offload the macro BS and to increase the number of users. The calculation results shows great enhancement in the small cell data rate by decreasing the cross-interference interference experienced by SCs. Most importantly, our scheme could be combined with power control or other interference reduction techniques.

## 6. REFERENCES

- [1]. Jeffrey G. Andrews, Stefano Buzzi, Wan Choi, et al. "What will 5G be". IEEE Journal on selected areas in communications, vol. 32, no. 6, p. 1065, 2014.
- [2]. Emil Bjornson, Luca Sanguinetti, Marios Kountouris. "Deploying dense networks for maximal energy efficiency: Small cells meet massive MIMO". IEEE Journal on Selected Areas in Communications, vol. 34, no. 4, p. 832–847, 2016.
- [3]. Thomas L. Marzetta. "Massive MIMO: an introduction". Bell Labs Technical Journal, vol. 20, p. 11–22, 2015.
- [4]. Emil Bjornson, Erik G. Larsson, Thomas L. Marzetta. Massive MIMO: "Ten myths and one critical question". IEEE Communications Magazine, vol. 54, no. 2, p. 114–123, 2016.

- [5].E. Björnson, L. Sanguinetti, H. Wymeersch, J. Hoydis, and T. L. Marzetta, "Massive MIMO is a Reality-What is Next? Five Promising Research Directions for Antenna Arrays," arXiv preprint arXiv:1902.07678, 2019
- [6].Hien Quoc Ngo, Erik G. Larsson, Thomas L. Marzetta. "Energy and spectral efficiency of very large multiuser MIMO systems". IEEE Transactions on Communications, vol. 61, no. 4, p. 1436–1449, 2013.
- [7].M. Z. Aslam, Y. Corre, E. Björnson, and E. G. Larsson, "Performance of a dense urban massive MIMO network from a simulated ray-based channel," EURASIP Journal on Wireless Communications and Networking, vol. 2019, no. 1, p. 106, 2019
- [8]. Jubin Jose,Alexei Ashikhmin, Thomas L. Marzetta, Sriram Vishwanath. "Pilot contamination and precoding in multi-cell TDD systems". IEEE Transactions on Wireless Communications, vol. 10, no. 8, p. 2640–2651, 2011.
- [9].Kianoush Hosseini, Jakob Hoydis, Stephan ten Brink, and Merouane Debbah. "Massive MIMO and small cells: How to densify heterogeneous networks". In Communications (ICC), IEEE International Conference, p. 5442–5447, 2013.
- [10]. Rajoria, Shweta, Aditya Trivedi, and W. Wilfred Godfrey. "A comprehensive survey: Small cell meets massive MIMO." Physical communication vol.26, p.40-49, 2018.
- [11].Hieu Duy Nguyen, Sumei Sun. " Massive MIMO versus small-cell systems: Spectral and energy efficiency comparison". In Communications (ICC), IEEE International Conference on, p. 1–6, 2016.
- [12]. S. Andreev, V. Petrov, M. Dohler, and H. Yanikomeroglu, "Future of ultra-dense networks beyond 5G: harnessing heterogeneous moving cells," IEEE Communications Magazine, 2019
- [13].Duy Trong Ngo, Tho Le-Ngoc. "Architectures of small-cell networks and interference management". Springer, 2014.
- [14]. David Muirhead, Muhammad A. Imran, Kamran Arshad. " A Survey of the Challenges, Opportunities and Use of Multiple Antennas in Current and Future 5G Small Cell Base Stations". IEEE Access, vol. 4, p. 2952–2964, 2016.
- [15].<https://www.ipaccess.com/en/viper/enterprise-small-cells>.
- [16].Siavash M. Alamouti. "A simple transmit diversity technique for wireless communications". IEEE Journal on selected areas in communications, vol. 16 no. 8, p. 1451–1458, 1998.
- [17].Thomas L. Marzetta. "Noncooperative cellular wireless with unlimited numbers of base station antennas". IEEE Transactions on Wireless Communications, vol. 9, no. 11, p. 3590–3600, 2010.
- [18].Small cell forum, Interference management in UTMS UMTS femtocells, [http://scf.io/en/documents/003\\_Interference\\_management\\_in\\_UMTS\\_femtocells\\_high-band.php](http://scf.io/en/documents/003_Interference_management_in_UMTS_femtocells_high-band.php)
- [19].<https://www.itu.int/rec/R-REC-P.1411-9-201706-I/en>.
- [20].<https://www.itu.int/rec/R-REC-P.1238-9-201706-I/en>.