

## Journal of Soil Sciences and Agricultural Engineering

Journal homepage: [www.jssae.mans.edu.eg](http://www.jssae.mans.edu.eg)  
Available online at: [www.jssae.journals.ekb.eg](http://www.jssae.journals.ekb.eg)

### Investigation an Electronic Device to Complement the Common Planter Feeding Device



Cross Mark

EL-Sheikha, A. M.<sup>2</sup>; H. Shabrawi<sup>1</sup>; Y. A. Mera<sup>1\*</sup> and M. E. Ghazy<sup>1</sup>

<sup>1</sup> Agric. Eng. Dept., Fac. of Agric. Mansoura Univ., Egypt

<sup>2</sup> Agric. Eng. Dept., Fac. of Agric. Domiat Univ., Egypt

#### ABSTRACT

This study was carried out to complement void of seed/grain during planting with common feeding device using an electronic unit. The modified planter consist of two feeding system namely, the main feeding with cells/disc device and the complementary feeding with cone hole device. These systems calibrated under condition when a seed/grain for any reason is voided from the main feeding device, the other device automatically compensate it. To meet this goal, three sensors were conducted into two feeding systems. An electronic circuit designed at private sector that involves PIC 16f877 connected with LM016LCD and pot-hg resistor that located in box. Also, A there IR sensors and electrical lever connected to electronic circuit that operates by 3V battery. A cylinder seed box IR and cone seed box IR were placed at point of seeds out to receive and record the seed number out from cylinder and cone box respectively. Guide-gear sensor is the third IR sensor that placed on front of guide gear to send signal to PIC. The experiments were done under four travel speed levels of investigated planter, four of different feeding number revolution ratio and land wheel revolution. The results indicated that ; using the complementary feeding device solve the problems of void seeds that decreased by about 0% compared with normal device. Also, the feeding system efficiency increased by about 1.2 times at 1.42 m/sec per reduction ratio of 0.49

**Keywords:** Metering device , Planters , complementary feeding , electronic feeding

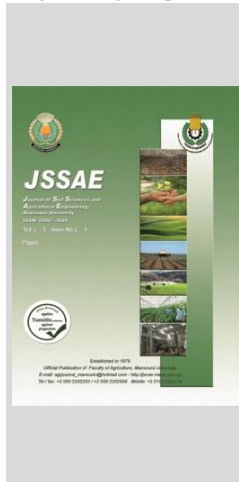

#### INTRODUCTION

All over ages, there was a big problem facing agricultural machinery especially for planters feeding device. Because of unequal span between plants per rows and void, a double seed leads to a decline in the percentage of germination and ultimately lead to lower productivity of the crop. According this problem, an investigation is conducted a new device to complement the common feeding device. There are many researchers trying to solve this problem through many ways but that's not enough. On this search, the investigation is conducted to investigate a new system to complement common feeding device using electronic unit. In field test, Awady *et al.* (2000) stated that increasing of mechanical seed drill planting speed from 2.18 to 5.46 km/h (feeder speed from 16.8 to 42.6 rpm) decreased emergence of wheat grains from 96.82% to 95.83% at gate opening 500 mm<sup>2</sup>. But for pneumatic grain drill, increasing forward speed from 2.18 to 5.46 km/h (feeder speed from 15.0 to 38.4 rpm) decreased germination of wheat grains from 97.93 to 97.12%. Clinton (1983) pointed out that plate-less planter such as finger pickup metering, feed cup metering or by one of several air metering methods reducing the problem of uncorrected size plate relative to seeds size. On the other side, Dannell (1983) used a finger pickup metering mechanism for corn kernel. He pointed out that, the finger pickup metering mechanism is designed for speed seeding of single kernel of corn. The lever control of the seeds tank bottom and the amount of feeding device parameters are considers as the main static factors influence of the seeding performance. While, the spacing uniformity, seed volumetric rate and

irregular dispersion of seeds in soil for soya bean planting are considers as the main out let factors (Ismail -2004). In crop production, the main condition for high productivity depends on seeds being in the optimum living area. In other words, it is necessary for seeds to be placed at equal intervals within row. With uniform spacing, the roots can grow to a uniform size (Karayel and Ozmerzi-1999). Although, there are many planters having different seed metering units. The application of pneumatic single seed planters has rapidly increased due to the fact that their seeding performance is better than that of the others. In additions, the devices of mechanical seed metering used in conventional drills are not capable of operating at high travel speed (Soza *et al.* 2007). Bahnasawy (1992) founded that the grain yield decreased with increasing forward speed of the seeder, where the highest yield of grain was recorded at 3 km/h speed. Meanwhile, the lowest yield was recorded at 8 km/h speed. These results may be due to that increase in velocity causes disturbance in seed-depth and seed spacing. Finally, to help for solving the above problems, the aim of this study is conducted the experiments to evaluate the performance and operating parameters of a developed precision feeding device depending on complementing voids of corn kernel by adding addition feeding device with electronic unit.

#### MATERIALS AND METHODS

A simple prototype of corn planter that connected with improved metering device is manufactured in private workshop at Meet Ali village, Dakhalia Governorate Egypt. It consists of the following parts as shown in Fig (1)

\* Corresponding author.

E-mail address: [Youssef.mera@yahoo.com](mailto:Youssef.mera@yahoo.com)

DOI: 10.21608/jssae.2019.62231

**Seeding box;**

It is the main part of corn planter which including two of seed/grain tanks that are fabricated from steel iron sheet of 3 mm thickness. The first tank has cylinder shape with dimensions 26.3 and 35cm, diameter and height respectively. The second seeding tank has conical shape with dimensions 28 and 35cm, diameter and height respectively. They were designed to ease drop seeds/grain out to feeding system.

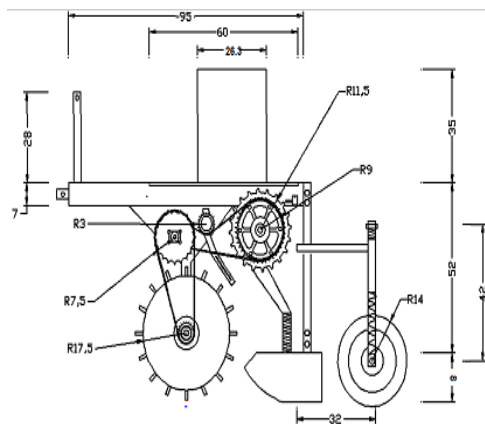

E.L.E.V.

**Main metering device:** Under this study, the investigating prototype of planter is specified for planting one row. A single aluminum feeding disc with 0.5 cm thickness, 26 cm outer diameter and 23 cm inner diameter. It having 22 cells distributed surrounding its edge. It designed to give a single seed/kernel fill out into delivery tube at equal share distance and it fixed in the base of cylinder seed box.

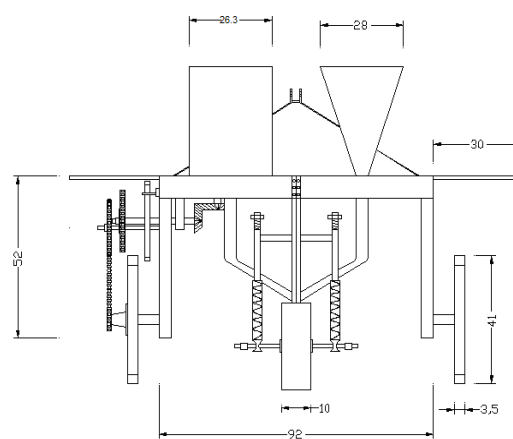

S.V.

**Fig. 1. The control modified of feeding system**

**Complementing device;**

An electronic metering device constructed to complete the void/miss during planting that's designed at private workshop. It consists of pic 16f877 connected with LM016LCD and pot-hg resistor. All above shares located in box. Also, there are three IR sensors and electrical lever connected with electronic circuit that operated by 3V battery.

**Furrow opener;**

A single furrow opener was used to put the seeds in soil position. The dimensions of furrow opener are 30 cm length, 4 cm width and 8 cm height.

**Press -wheel system;**

One press wheel was used to cover the seeds/grains with soil. The width dimensions of wheel cover of 10 cm.

**Main frame;**

It made from iron channel beam with cross section of 100×60×5 mm. It consists of four welded parts with length of 92 cm. The main frame dimensions of 95×92×7cm, length, width and thickness respectively. The hitch point of second category was willed with the main frame to ease three connect the prototype with tractor.

**Transmission system;**

It has two functions for driving metric device from ground wheel and for changing the rotating speed to obtain different application seed rates (kg/feddan). The motion was transmitted from the planter wheel by means of gears and chain drives as shown at Fig (2)

**Control wheel**

As shown in Fig. (2), The ground wheel gear of 15 teeth and 6 cm diameter transmits the motion to the first idler-shaft gear (3) of 37 teeth and 14.5 cm diameter then to the second idler-shaft gear (4) of 24 teeth and 9.5 cm diameter. Four different variable of gear were designed from iron material having 20, 15,12.5 and 9.5 cm diameters and

52, 38, 32 and 24 teeth respectively, to obtain different application seed rates. Use to change the gears connection by specific gear called tension gear (7) which has 15 teeth and 6 cm diameter. The guide gear of metering shaft (6) which has 22 teeth and 26 cm diameter is bolted in the same shaft of metering shaft gear (5). The guide gear and the seed metering disc having the same dimension and number of teeth. The motion can transmitted arrangement allowed ground wheel and metering disc speeds.

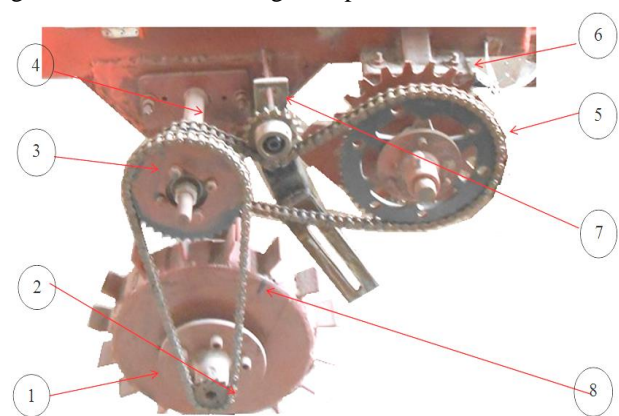

**Fig. 2. transmission –system**

- 1-Ground wheel
- 2-Ground wheel gear
- 3- First idler- shaft gear
- 4-Second idler- shaft gear
- 5-Metering shaft gear
- 6-Guide gear
- 7-Tension gear
- 8- Chains

**Control system**

Three IR photo diode sensor were used to control seeds flow during planting process depending on the signal that cutting the path of transmitter (IR LED) and the receiver (IR Photodiode). The guide gear sensor related to cylinder seed box sensor move a electrical lever to on off seeds flow. When the teeth gear passed on the guide gear sensor and there is no seed falling on the cylinder seed box sensor, the

electrical lever opened to supply seed and then closed automatically. the number of dropped seeds from two hopper were indicated at the screen that located at front of tractor.

The experimental lab group was provided with a lathe as a source of power that converted rotating speed, the power transported from lathe to four different metering gear through two pulleys and belt as shown in Fig.3. The performance of control modified system were compared at four different rotating speed are (24, 34, 46, 65 rpm) to identify four reduction ratio (0.22, 0.31, 0.36, 0.49).



**Fig. 3. The transmission unit was provided with a lathe as a source of power**

The following measurements evaluate for investigated prototype;

**Application rate (AR) calculation**

The falling kernel form seed tube per hour “t, hours” at different reduction ratio were weighted “M” and the application rates were calculated from the following equation:-

$$AR = \frac{M_1}{t}$$

The field experimental area was about 22.5 x40 m<sup>2</sup>, according to the experimental data that divided into eight parts relative to gear teeth (52, 38, 32, 24 teeth) and forward speeds (0.64, 0.89, 1.19, 1.42 m/sec) with and without using the electronic device.

**Seeds spacing in-row**

is evaluated by measuring the space between seeds in rows for each treatments under experiments.

- **Seeds void (%)** is the seed void when the distance (S<sub>c</sub>) between seeds in rows is twice greater that of pre-adjusted distance(S<sub>t</sub>=25 cm). there were calculated from the following equation

$$Vs = \frac{m_n}{M} \%$$

**Where**

Vs = percentage of seeds void, %

M = theoretical number of seeds at limit of operating planter

mn = number of spacing sc ≥ 25t ≥ 50 cm at same limited time

**Seeds doubles %** are calculated when the distance between in a row (sc) is half or less than the pre-adjusted space in the row (st). I.e.,  $sc \leq (st/2) \leq 12.5cm$ , It is calculated using Ismail's (2004) method

**Visible grain damage (VD);**

Visible grain damage was determined for each sample before and after its passing through feeding system of planting machine. Percentage of visible grain damage was estimated through the following equation: -

$$(VD \%) = \frac{V1- V2}{500} \times 100$$

**Where;**

V1 = Number of damaged kernel of corn in sample ( 500 grains) , which randomly segregate from every corn main sample after its passing through seed drill feeding system.

V2 = number of damaged kernel of corn before passing grains sample (500 grains) through seed drill feeding system.

**Germination test;**

Un visible grain damage was carried out at laboratory to determine the internal invisible damage of grains. A randomized sample of (100 grains) were taken and planted in Petri dishes to determine the germination percentage. The results were recorded after ten days from planting to estimate the germination percentage. It was from the following equation

$$(ID\%) = \frac{N2-N1}{N2} \times 100$$

**Where:-**

N1 = Number of growing grains

N2 = Number of planting grains (100 grains)

**Total grain damage (TD);**

The percentage of visible grains damage (VD %) summated with invisible grains damage percentage (ID %), were estimated to calculate total damage (TD, %)

**RESULTS AND DISCUSSION**

**Application rate**

Fig. 4 shows the effect of land wheel rotation on application rate. From results of figure, It can be seen that the application rate decreased by increasing land wheel rotation level. The highest application rate recorded about 17.58kg/h was gained by using speed 24 rpm at reduction ratio of 0.49. But, the lowest application ratio recorded 1.5kg/h at speed of 24rpm per reduction ratio of 0.22. These results may be due to increasing seeds/kernel void at high speed.

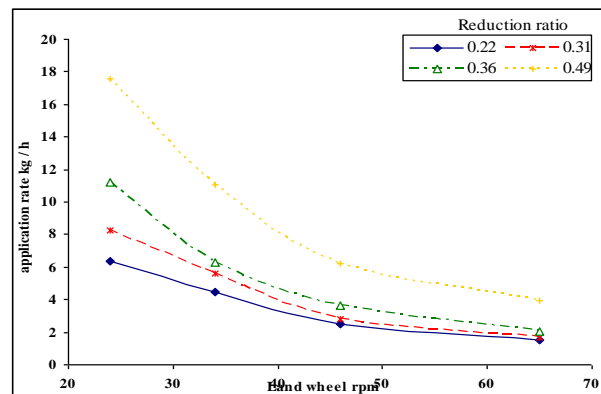

**Fig. 4. Effect of land wheel rotation on application rate**

**Void percentage of planter:**

Fig. 5 shows the effect of planting speed on void ratio for planter without applied electronic device. From results, the void ratio increased by increasing planting speed level. The highest void ratio "Vy" recorded about 70%. It was gained by using planting speed of 1.42m/sec at reduction ratio of 0.22. But, the lowest void ratio recorded 10% at speed of 0.64m/sec per reduction ratio of 0.22. These results may be due to the lower efficiency of planting without using electronic device.

A regression type of polynomial analysis was applied to relate the change in "Vy" under the effect of

each of planting speed (Ps). The obtained regression equations were in the form of:

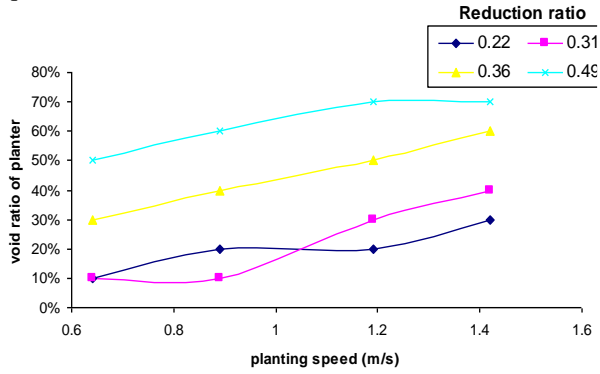

Fig. 5. Effect of planting speed on kernel void percentage of planter

$$V_y = 0.0305 P_s^2 + 0.1592 P_s \quad R^2 = 0.8709$$

$$V_y = 0.227 P_s^2 - 1.0376 P_s \quad R^2 = 0.9103$$

$$V_y = 0.4968 P_s \quad R^2 = 0.9955$$

$$V_y = 1.0047 P_s \quad R^2 = 0.9101$$

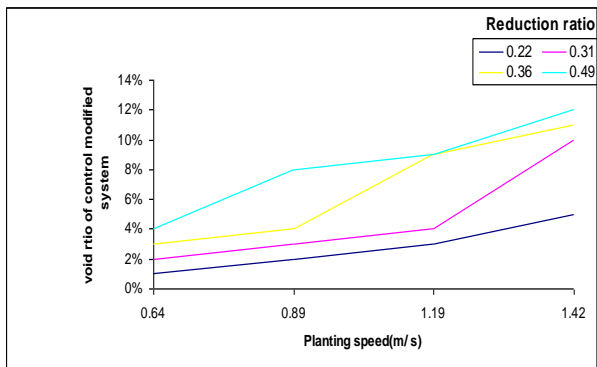

Fig. 6. Effect of planting speed on kernel void percentage of control modified unit

$$V_y = 0.001 P_s^3 + 0.007 P_s \quad R^2 = 0.9955$$

$$V_y = 0.0048 P_s^2 + 0.0039 P_s \quad R^2 = 0.9101$$

$$V_y = 0.0013 P_s^2 + 0.023 P_s \quad R^2 = 0.8709$$

$$V_y = -0.0037 P_s^2 + 0.044 P_s \quad R^2 = 0.9103$$

The effect of planting speed on void ratio "Vy" after applied the electronic device is illustrated in Fig. 6. From results the void ratio increased by increasing planting speed level. The highest void ratio recorded about 12% was gained by using planting speed 1.42m/sec at reduction ratio 0.22. Nevertheless, the lowest void ratio recorded 1% at speed of 0.64m/sec per reduction ratio of 0.22. These results may be due to using control modified system which compensates void percentage. The relationship between the actual and predicted values from above equations of void ratio is clear that predicted values nearly to close with actual.

**Double ratio of control modified system:**

Figure7 shows the effect of planting speed on double ratio. It can be seen that the double ratio increased by increasing planting speed level. The highest double ratio recorded about 12% was gained by using planting speed 1.42 m/sec at reduction ratio 0.22. But, the lowest double ratio recorded 2% at speed of 0.64 m/sec per reduction ratio of 0.49. These results may be due to increasing of spaces between plants especially when using high planting speed level.

**Planting efficiency**

Before modification, the effect of planting speed on planting efficiency of planter is conformed as shown in Fig. 8. The feeding system efficiency is decreased by increasing planting speed level. The highest feeding system efficiency recorded about 80% was gained by using

planting speed of 0.64m/s at reduction ratio of 0.31. Whereas, the lowest feeding system efficiency recorded about 30% at planting speed of 1.42km/h per reduction ratio of 0.49. These results may be due to increasing of voided or double percentage. The effect of planting speed on planting efficiency after applied the electronic device is illustrated in Fig.9. From figure results, the feeding device system efficiency decreased by increasing planting speed level . The highest feeding system efficiency using electronic unit recorded about 98% was gained by using planting speed 0.64 m/sec at reduction ratio 0.22. but, the lowest feeding system efficiency using electronic unit recorded 76% at speed of 1.42m/s per reduction ratio of 0.49

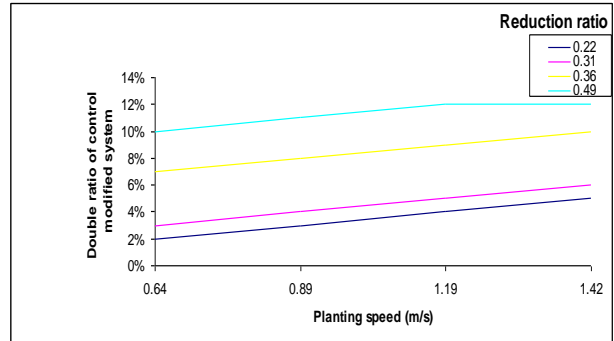

Fig. 7. Effect of planting speed on kernel double ratio of control modified system

**Visible grain damage (VD)**

The Fig.10 shows the effect of land wheel rotation on visible grain damage at laboratory. From results of figure, it can be seen that the visible grain damage increased by increasing land wheel rotation level. The highest visible grain damage recorded about 4% was gained by using speed 65 rpm at reduction ratio 0.49. Nonetheless, the lowest visible grain damage recorded 0.33% at speed of 24rpm per reduction ratio of 0.22.

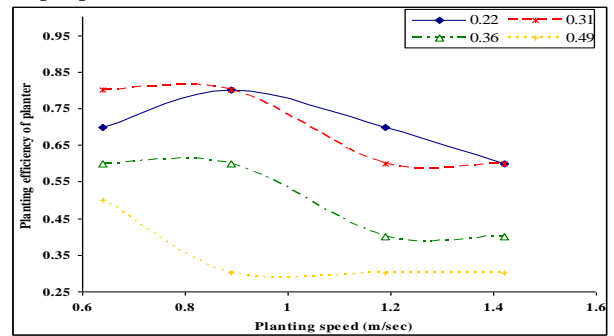

Fig. 8. Effect of planting speed on planting efficiency of planter

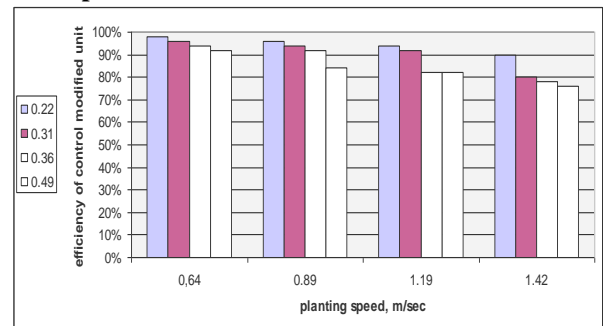

Fig. 9. Effect of planting speed on planting efficiency of control modified unit

### Total grains damage percentage (TD%)

The (Fig11) shows the effect of land wheel rotation on total grain damage. From results of figure, It can be seen that the total grain damage increased by increasing land wheel rotation level. The maximum total grain damage recorded about 7.77% was gained by using speed 65 rpm at reduction ratio 0.49. but, The minimum visible grain damage recorded 0.66% at speed of 24rpm per reduction ratio of 0.22.

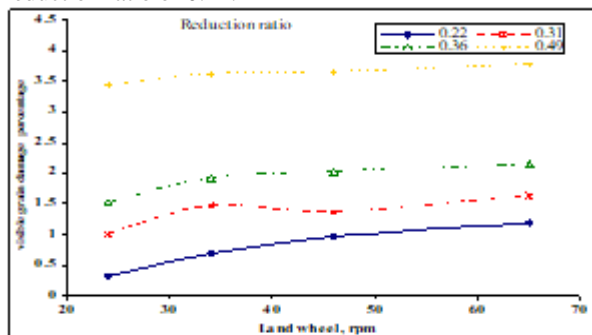

Fig. 10. Effect of land wheel rotation on visible kernel damage (VD)

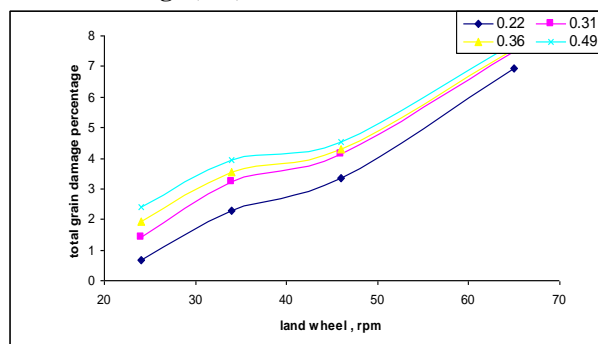

Fig.11. Effect of land wheel rotation on total kernel damage

### CONCLUSION

Adding an electronic device to planter lead to increasing of planting efficiency and that the aim of this

search which the highest feeding system efficiency using electronic unit recorded about 98% was gained by using planting speed 0.89 m/sec at reduction ratio 0.22 but Before modification the highest feeding system efficiency recorded about 80% was gained by using planting speed of 0.64m/s at reduction ratio of 0.31 and the lowest void ratio when adding the electronic device recorded 1% at speed of 0.64m/sec per reduction ratio of 0.22 But, the lowest void ratio without electronic device recorded 10% at speed of 0.64m/sec per reduction ratio of 0.22.

### REFERENCES

- Awad, M.N.;G. H. El-Sayed; I. Yehia and Alla, H.A. Mohamed (2000) Evaluation and comparison of mechanical and pneumatic drills for wheat grains "8 th conf. of Misr Society of Agric . Eng ., 25 -26. October 2000, 123 – 136
- Bahnasawy, A. H.(1992) . Effect of machine parameters pertinent to planting effectiveness of some crops. M. Sc .Th. Univ . of zagazig at moshtohor; 44 -86
- Clinton O.J. "Agricultural power and machinery. " planting and seeding equipment . 336-354.
- Dannell H. (1983). "Farm power and machinery management . " Seedling machine eight edition .pp 102-111.
- Ismail Z. E. (2004). The first report of project (Developing the Metering Unite of the Pneumatic Planter) financed by Mansoura University researches unite
- Karayel D. and A. Ozmerzi (2007). Comparison of vertical and lateral seed distribution of furrow openers using a new criterion. Soil land tillage Research (95), 69-75.
- Soza E. , G. Botta, M. Tourn and R. Hidalgo (2007). Sowing efficiency of two seeding machines with different metering device and distribution systems: a comparison using soybean. Spanish journal of Ag, Re. 2 (3), 315-321.

### تقييم اقتراح لنظام تغذية الكتروني مكمل لأله الزراعة في صفوف

أحمد محمد الشيخة<sup>٢</sup>، حسنى الشبراوى المرسي<sup>١</sup>، يوسف عبد السلام ميره<sup>١\*</sup> و محمد إبراهيم غازى<sup>١</sup>

<sup>١</sup> قسم الهندسة الزراعية – كلية الزراعة – جامعة المنصورة

<sup>٢</sup> قسم الهندسة الزراعية – كلية الزراعة – جامعة دمياط

أجريت دراسة علي نظام الكتروني مكمل لجهاز التلقيح في اله الزراعة في الصفوف الهدف منها التخلص من الجور الغائبة أثناء عملية الزراعة وتتكون وحدة الزراعة الإضافية المكمل من وحدتي تلقيح عبارة عن وحدة التلقيح الأساسية والذي يتكون من خزان رئيسي يحتوي علي قرص تلقيح أفقي مزود بمجموعة من الخلايا علي محيطه الخارجي ووحدة التلقيح الإضافية والتي تتكون من خزان مخروطي مزود بفتحة تلقيح وترس مثبت في أقصى الجانب الأيمن من الاله يعمل كدليل وزراع الكتروني مثبتة أسفل وحدة التلقيح الإضافية وتمت معايرة برمجة النظام الالكتروني بحيث أثناء غياب البذور من وحدة التلقيح الأساسية يقوم الجهاز المكمل بتعويضها وتتكون النظام المكمل من دائرة الكترونية حيث تم تصنيعها في ورشه خاصة تتكون من مايكروكنترولر متصل بشاشة رقمية ومجموعة من المقاومات مثبتة داخل صندوق متصلين ببوابه الكترونية وثلاثة حساسات أشعة تحت حمراء ضوئية موزعين بحيث يتواجد الحساس الأول أسفل الخزان الاسطواني في جهاز التلقيح الأساسي ويعطي إشارة بعدد البذور الساقطة عليه علي شاشته رقميه والحساس الثاني مثبت أسفل الخزان المخروطي في وحدة التلقيح الإضافية ويعطي إشارة بعدد البذور الساقطة عليه علي نفس الشاشة والحساس الثالث مثبت في أقصى الجانب الأيمن من الاله أمام الترس الدليل وعندما تمر أسنان الترس الدليل خلال الحساس الثالث وفي نفس الوقت لا توجد بذور تمر علي الحساس الأول تفتح الزراع الالكترونية وتغلق أوتوماتيكيا حيث تم تثبيتها أسفل الحساس الموجود في وحدة التلقيح الإضافية وقد أجريت التجارب عند سرعات مختلفة وأشارت النتائج إلي أن باستخدام الأجهزة التكميلية نقضي علي مشكلة الجور الغائبة مقارنة بالجهاز العادي والتي انخفضت بنسبة حوالي صفر كنسبة مئوية ومقارنة بالجهاز العادي أيضا زادت كفاءة جهاز التغذية بحوالي ٢,١ مرة عند سرعه ٤٢,١ م/ ث عند نسبة تخفيض ٤٩,٤.