

Military Technical College  
Kobry Elkobbah,  
Cairo, Egypt



2<sup>nd</sup> International Conference on  
Electrical Engineering  
ICEENG 99

## COMPUTER BASED IMPLEMENTATION OF AN AUTOMATIC CAR CARBURETOR SYSTEM

GAMAL M. I. SELIM\*, MAHMOUD M. A. ASHRY\*\*

### ABSTRACT:

This paper presents the design and implementation of a computer based system to control the fuel to air ratio in a car carburetor system. The mathematical model of the system is introduced, the PID controller design is elaborated and the simulation results are obtained. Finally, the implementations of the controller using analog PID and digital PID are introduced and compared.

### KEY WORDS:

PID controller stands for proportional, integral, and derivative controller.

---

\*Dr., Radar and Guidance Dpt., Military Technical College, Cairo, Egypt.

\*\*M.Sc. student, Radar and Guidance Dpt., Military Technical College,  
Cairo, Egypt.

## 1- INTRODUCTION:

Up until the 1980's, most automobile engines had a carburetor to meter the fuel so that the ratio of the gasoline mass flow to air mass flow (F/A) remained in the vicinity of 1:15. This device metered the fuel by relying on a pressure drop produced by the air flowing through a venturi. The device has performed adequately for the last 100 years in terms of keeping the engine running satisfactorily, but has historically allowed excursions of up to 20%. After the implementation of exhaust pollution regulations, these F/A excursions were unacceptable. During the 1970's, automobile companies improved the design and manufacturing process of the carburetor so that they became more accurate and delivered an accuracy in the vicinity of 3% to 5%. Through a combination of factors, this improved F/A accuracy helped lower the exhaust pollution to acceptable levels. However, the carburetors were still open-loop devices in that no measurement was made of F/A that entered the engine for subsequent feed back into the carburetor.

During the 1980's, almost all manufacturers have turned to feedback control systems to provide a much-improved level of F/A accuracy, an action made necessary by the decreasing levels of allowable exhaust pollutants.

The method chosen to meet the exhaust standards has been to use a catalytic converter that simultaneously oxidizes excess levels of exhaust carbon monoxide (CO) and unburned hydrocarbons (HC) and reduces excess levels of the oxides of nitrogen (NO and NO<sub>2</sub> or NO<sub>x</sub>). This device is usually referred to as a "three-way catalyst" because of its effect on all three pollutants. This catalyst is ineffective when the F/A is more than ±1% different from the stoichiometric level of 1:14.7; therefore, a feedback control system is required to maintain F/A within ±1% of that desired level [1].

## 2-MODELING:

The system is shown in figure (1) in which the signal from the sensor o/p will affect the actuator.

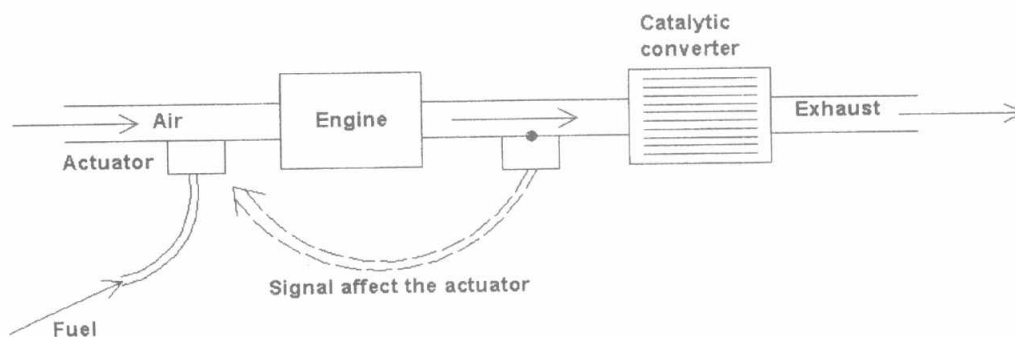

Figure (1)

The dynamic phenomena that affect the relation between the sensed F/A output from the exhaust and the fuel metering command in the intake manifold are:

- Intake fuel and air mixing.
- Cycle delays due to the piston strokes in the engine.
- The time required for the exhaust to travel from the engine to the sensor.

All these effects are strongly dependent on the speed and load of the engine. The system undergoes transients as the driver demands more or less power through changes in the accelerator pedal, with the changes taking place over fractions of second.

Ideally, the feedback control system should be able to keep up with these transients.

### 2-1- The Sensor:

The discovery and development of the exhaust sensor was the key technological step that made this concept of exhaust-emission reduction possible. The device is made of zirconia; it is placed in the exhaust stream and yields a voltage related to the oxygen content of the gases. The F/A is uniquely related to the oxygen level. The voltage of the sensor is highly non-linear with respect to F/A as in figure (2), with almost all the change in voltage occurring precisely at the F/A where the feedback system must operate for effective performance of the catalyst. Therefore the gain of the sensor will be very high when the F/A is at the desired point (1:14.7), but will fall off considerably for F/A excursion away from 1:14.7.

A first approximation to the sensor is shown in figure (3). Since the sensor gain at the set points is still quite different between the actual sensor and its approximation, this approximation will yield erroneous conclusions regarding stability about the set point; however, it will be useful in a simulation to determine the response to initial conditions.

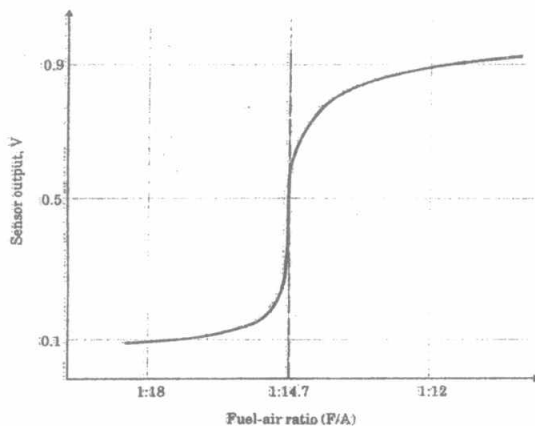

Figure (2)

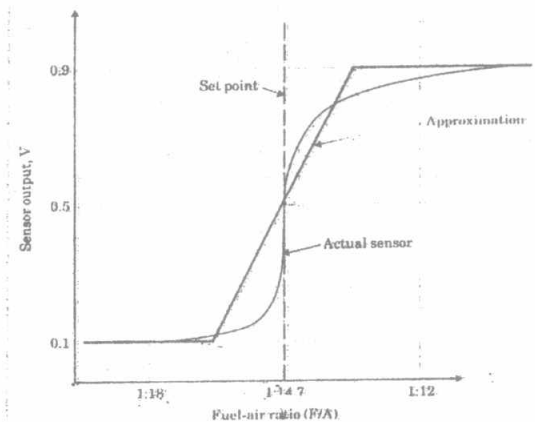

Figure (3)

### 2-2- The Actuators:

Fuel metering can be accomplished by a carburetor or by fuel injection. To implement a feedback F/A system, the capability of adjusting the fuel metering electrically is required, since the sensor used provides an electric output.

Carburetors have been designed to provide this capability by including adjustable orifices that modify the primary fuel flow in response to the electric error signal. Most designs accomplish this by the use of on-off solenoid valves that modulate the pressure applied to a bellows in the carburetor. The bellows moves a needle to adjust the orifice size. The advantage of this approach appears to be that it is the cheapest of the alternatives [1].

Since fuel-injection systems are typically electrical by nature, they can be used to perform the fuel adjustment for F/A feedback by simply including the capability of summing the feedback signal in computer code. In some cases, fuel injectors are placed at the inlet to every cylinder (called multipoint injection), and in some cases there is one large injector upstream (called single point or throttle body injection). With the growing popularity of microprocessor engine control, single-point fuel injection is becoming much more popular, apparently because its cost is approaching that of the carburetor. Differences in performance between the carburetor and single-point injection are not major, since they both introduce fuel at approximately the same location. Multipoint injection does offer improved performance because the fuel is introduced much closer to the engine, with better distribution to the cylinders. Being closer reduces the time delays and thus yields better engine response. Because of a significant cost penalty, however, multipoint-injection is typically only used on relatively expensive, high-performance automobile.

### 2-3- Linearization Of The System:

The sensor nonlinearity shown in figure (2) is severe enough that design effort based on a linearized model of it should be used with caution. Figure (4) shows the block diagram of the system, with the sensor have a gain  $K_s$  in the linear part which has the effect on the system performance.

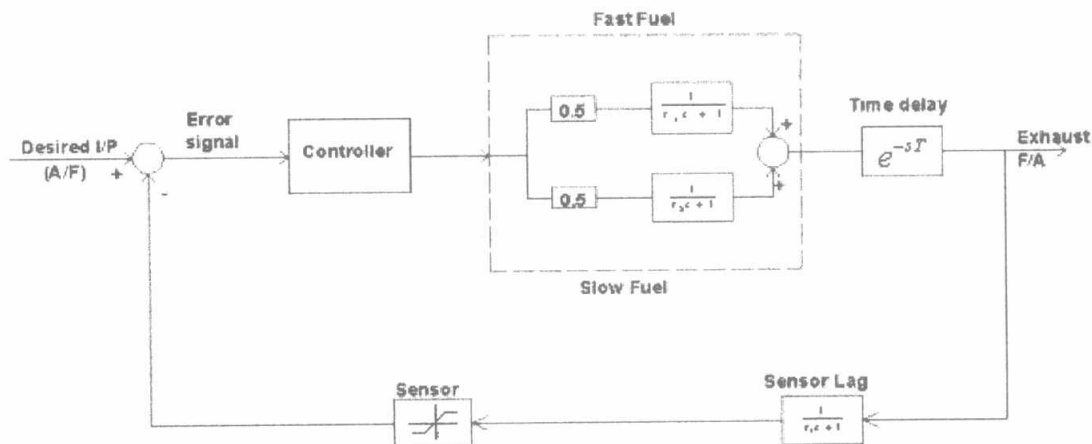

Figure (4)

- The two time constants indicated for the inlet manifold dynamics represent fast fuel flow in form of vapor or droplets and slow fuel flow in the form of liquid film on the manifold walls.
- The time delay is the sum of the delay caused by the four piston strokes from the intake process until the exhaust to travel from the engine itself to the sensor located perhaps 1 ft or so away.
- The sensor lag is also included in the process to account for the mixing that occurs in the exhaust manifold. Although the time constants and delay time change considerably, primarily as a function of engine load and speed, we will examine the design at specific point for normal operation where the values are [1]:

$$\begin{aligned} \tau_1 &= 0.02 \text{ sec.} & \tau_2 &= 1 \text{ sec.} \\ T &= 0.2 \text{ sec.} & \tau &= 0.1 \text{ sec.} \end{aligned}$$

### 3- PID CONTROLLER DESIGN:

It is required to design a suitable controller in order to satisfy the system requirements which in turn will improve the system performance. The system requirements are:

Steady state error ( $e_{ss}$ )  $\leq 0.01$  and  
the system must respond as fast as possible ( $T_s \leq 10$  seconds).

A PID controller is proposed for the controller design of this system.

For the system shown in fig (4) the total forward transfer function is given by:

$$G(S) = \frac{25.5S + 50}{(S + 50)(S + 1)} e^{-0.2S}$$

Using fifth order pade approximation for the time delay  $e^{-0.2S}$  we get:

$$G(s) = \frac{-0.0003S^4 + 0.0102S^3 - 0.22S^2 + 1.9372S + 4.725}{0.001S^4 + 0.0314S^3 + 0.5974S^2 + 5.292S + 4.725}$$

and the feedback transfer function is given by:

$$H(s) = \frac{K_s}{0.1S + 1}$$

The open loop transfer function can be written as:

$$G(s)H(s) = K_s \frac{-0.0003S^4 + 0.0102S^3 - 0.22S^2 + 1.9372S + 4.725}{0.0001S^5 + 0.0041S^4 + 0.0911S^3 + 1.1266S^2 + 5.7645S + 4.725}$$

The root locus for this system as  $K_s$  varies from 0 to  $\infty$  is given in figure (5)

The root locus shows that the system is conditionally stable for:

$$0 < K_s \leq 2.804$$

Since the value of  $K_s$  of the system = 2, so the system is stable in this case.

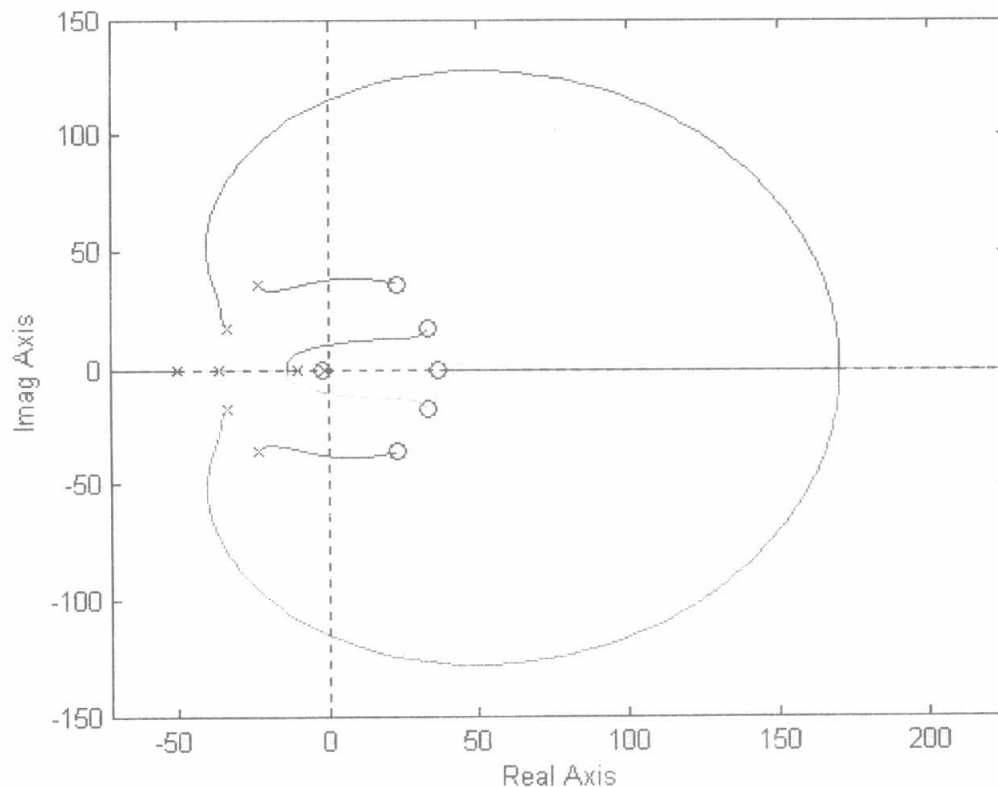

Figure (5)  
The root locus of the system

The system is simulated using simulink which is a real time simulation package. The simulation block diagram is shown in figure (6) and the output response and error signal are shown in figure (7) and (8) respectively.

The results show that the system is stable and both the transient and steady state responses are satisfied.

Since the system under study is subjected to disturbance as a result of sudden press of the acceleration pedal by the driver. This disturbance can be introduced to the system block diagram as a step input or a pulse input. The block diagram of the system after adding the disturbance input is shown in figure (9)

**Case 1:** the system is subjected to a step-input disturbance

The output response and the error signal are shown in figure (10) and (11) respectively.

**Case 2:** the system is subjected to pulse-input disturbance

The output response and the error signal are shown in figure (12) and (13) respectively.

The obtained results from both cases show that a high steady state error is obtained when the system is under driver disturbance. So a controller must be used in order to overcome this problem.

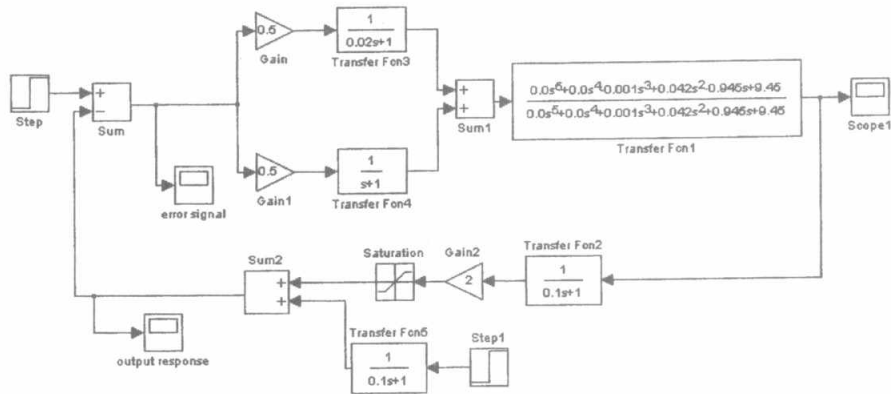

Figure (6)  
The simulation block diagram of the system

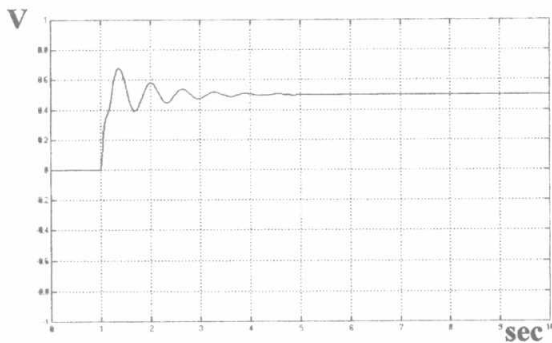

Figure (7)  
The output response of the system without controller

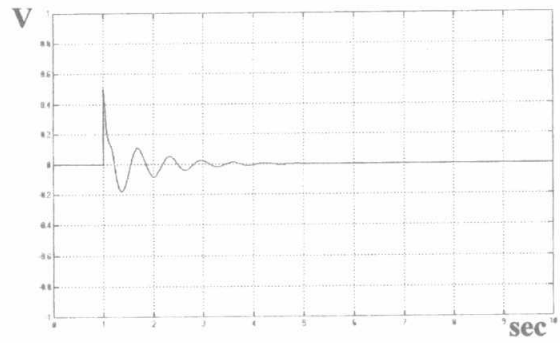

Figure (8)  
The error signal of the system without controller

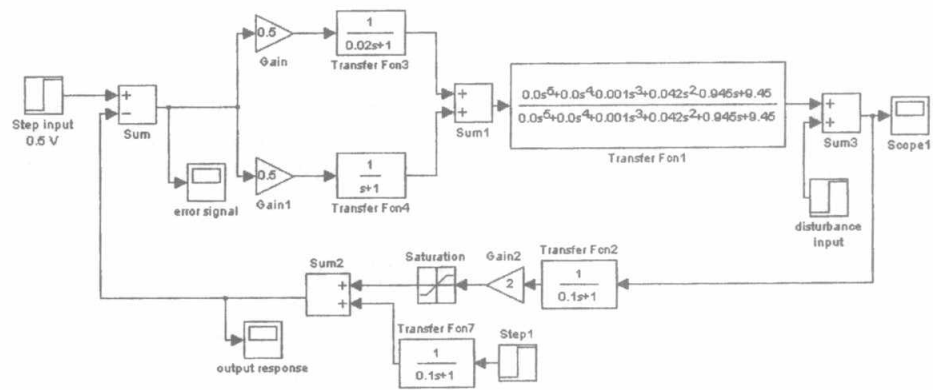

Figure (9)  
The block diagram of the system after adding disturbance input

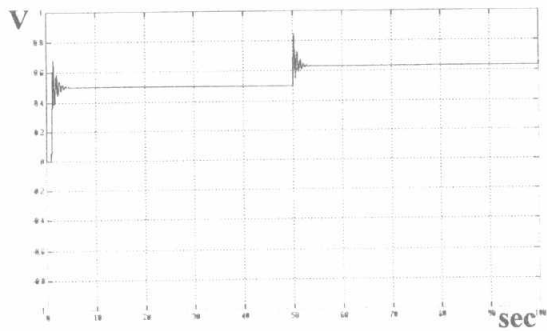

Figure (10)  
The output response when the system is subjected to a step input disturbance

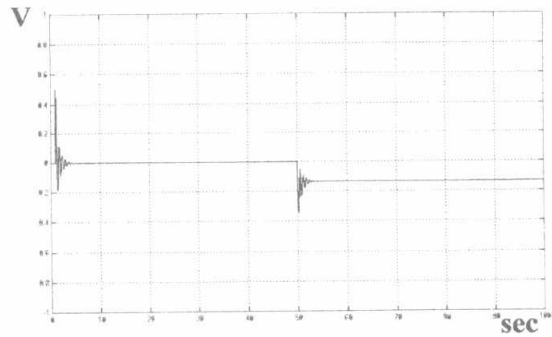

Figure (11)  
The error signal when the system is subjected to a step input disturbance

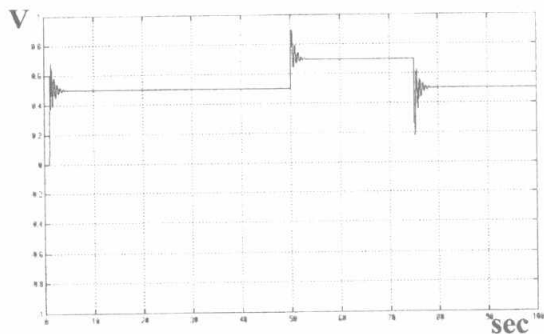

Figure (12)  
The output response when the system is subjected to pulse input disturbance

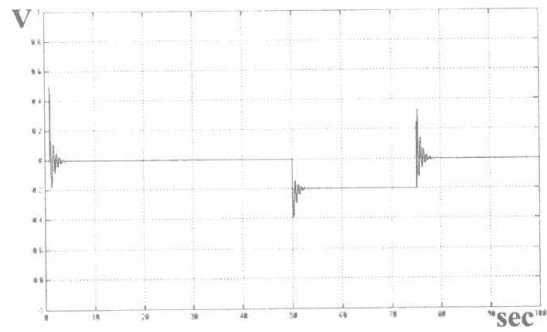

Figure (13)  
The error signal when the system is subjected to pulse input disturbance

A PID controller is inserted in the control system loop in order to overcome the above problem. The design of the PID parameters are verified using simulink package. The output response and the error signal of the system after inserting the PID controller when the system is not subjected to any disturbance are shown in figure (14) and (15) respectively.

Finally, two sets of results are obtained when the system is subjected to disturbance input. One set of results is obtained when the system is subjected to a step input disturbance and the other is obtained when the system is subjected to a pulse input disturbance. The output response and the error signal when the system is subjected to a step or a pulse input disturbance are shown in figure (16, 17) and (18, 19) respectively. From these results, we can deduce that the system under study has a zero steady state error in a very short period of time and these results remain true when it is subjected to disturbances. So, the PID controller which is inserted in the control system loop is suitable for the system to obtain satisfactory performance.



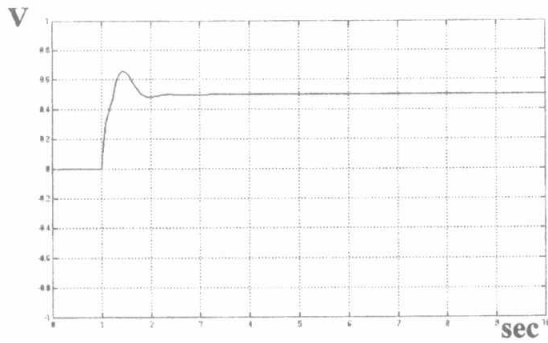

Fig (14)  
The output response after inserting the PID unit

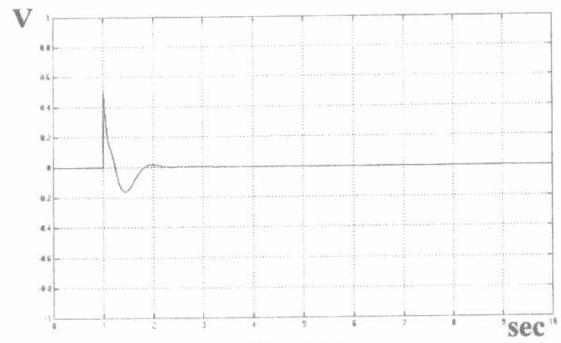

Fig (15)  
The error signal after inserting the PID unit

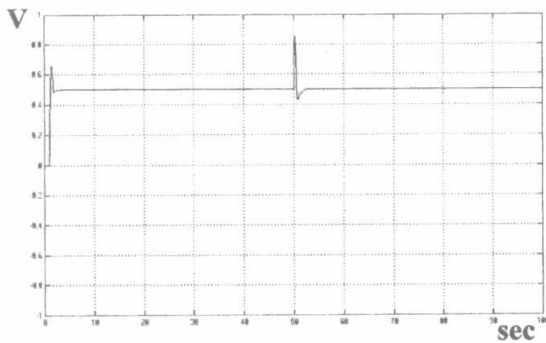

Figure (16)  
The output response after inserting the PID controller when the system is subjected to a step input disturbance

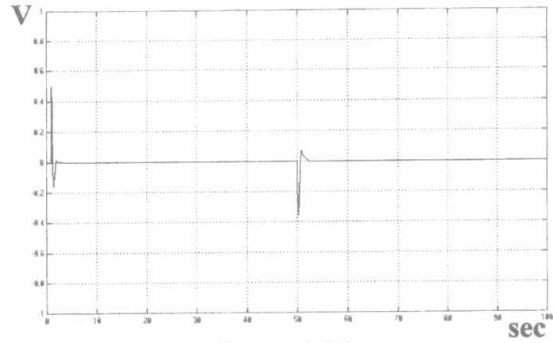

Figure (17)  
The error signal after inserting the PID controller when the system is subjected to a step input disturbance

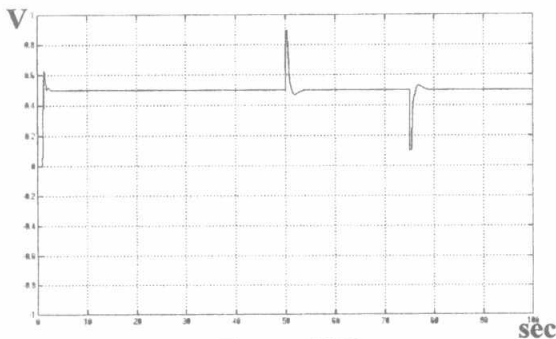
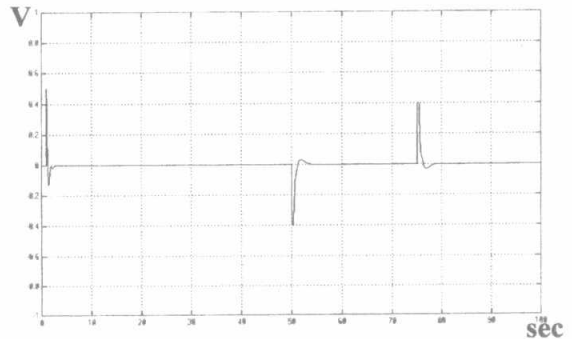

Figure (18)  
The output response after inserting the PID controller when the system is subjected to a pulse input disturbance



Fig(19)  
The error signal after inserting the PID controller when the system is subjected to a pulse input disturbance

#### 4- OVERALL REALIZATION OF THE SYSTEM USING ANALOG COMPUTER:

The system can be realized using the basic three units of the analog computer which are coefficient multiplier, summer, and integrator as shown in figure (20). PID controller parameters are adjusted according to the values obtained from the computer simulation results from part (3). The output response and the error signal obtained from the analog computer are shown in figure (21) and (22). The results obtained are approximately the same as that obtained from the computer simulation.

#### 5- REALIZATION USING COMPUTER BASED SYSTEM:

In order to improve the efficiency of a control system loop it is a good idea to replace the analog controller implementation by a digital one to overcome the problems associated with the analog computer amplifiers. The proposed digital implementation of the controller is shown in figure (23).

Selecting appropriate sampling frequency and convert the PID controller to its z-transform equivalent as:

$$G_D(Z) = K_P + \frac{K_I}{1 - Z^{-1}} + K_D(1 - Z^{-1})$$

Then, The program in the digital computer plays the same role as the analog PID unit. So it adjusts the values of  $K_P$ ,  $K_I$ ,  $K_D$  to give the output response needed. Figure (24) shows the output response and the reference input. From this figure it is clear that the output response will be approximately the same as the reference input after less than 5 seconds and so the error signal approximately zero. Finally, figure (25,26) show the output response and the reference input when the system is subjected to step input and pulse input disturbances.

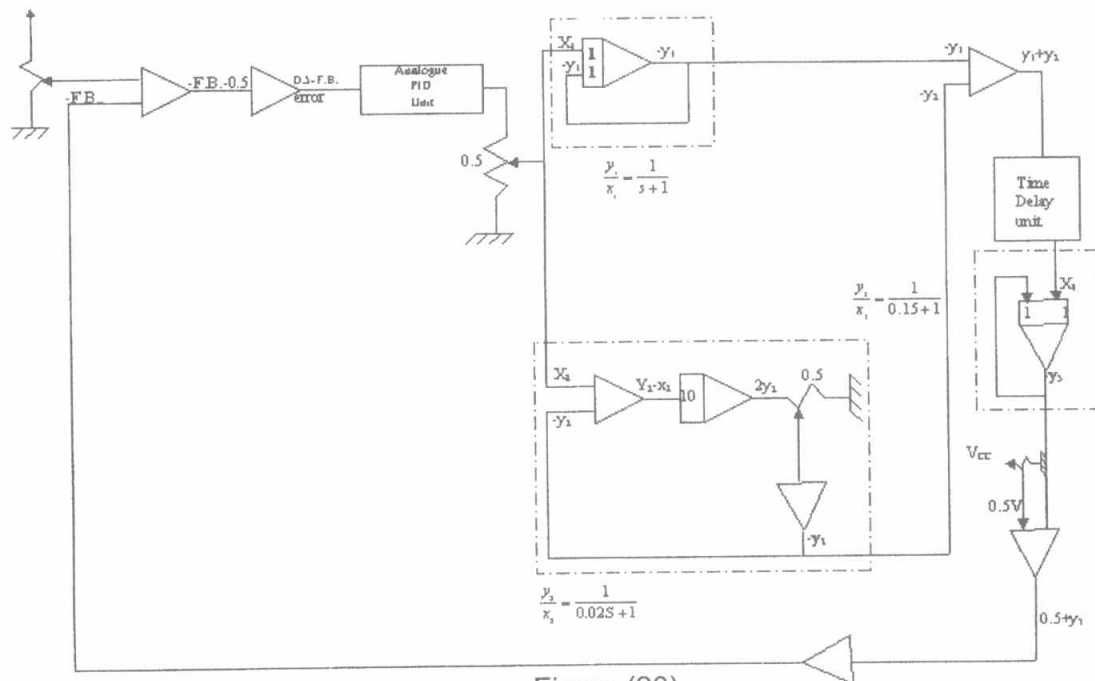

Figure (20)

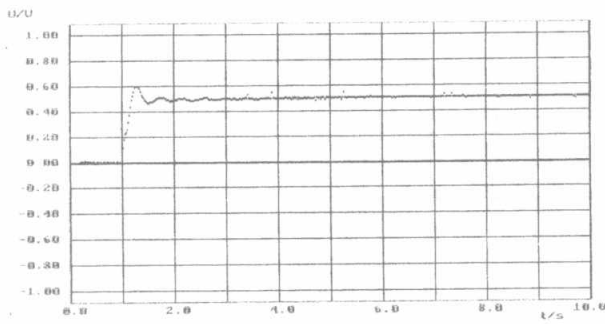

Figure (21)  
The output response from analog computer

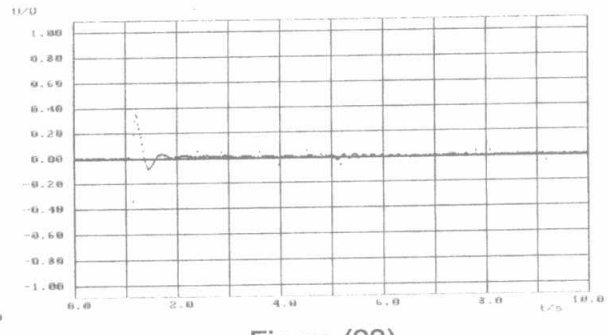

Figure (22)  
The error signal from the analog computer

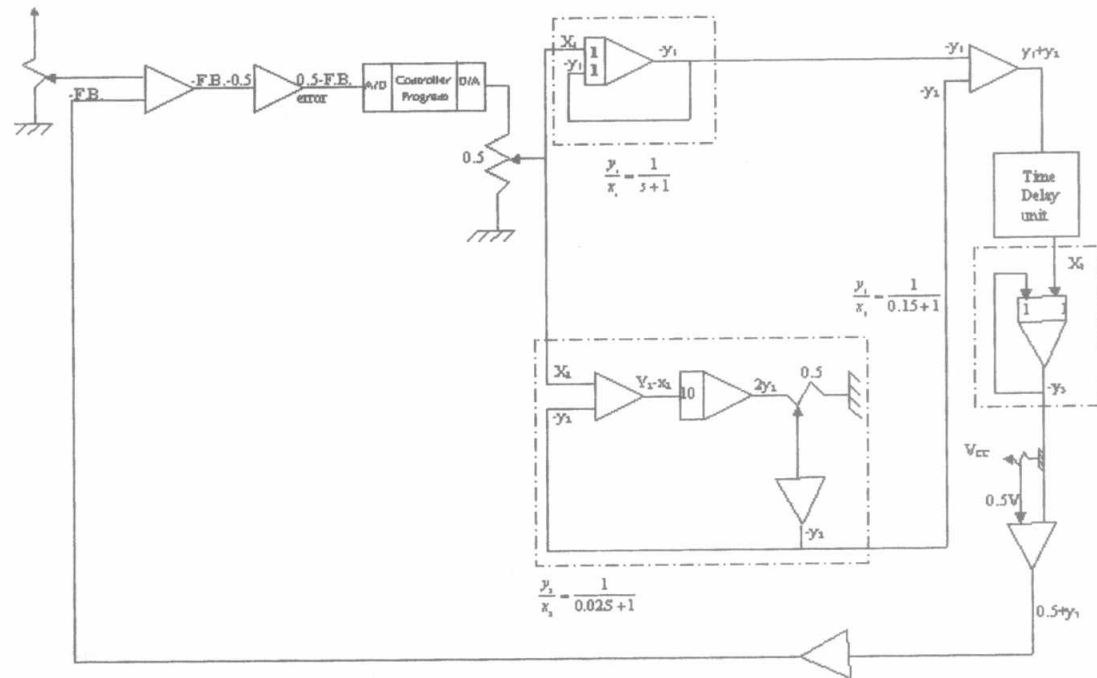

Figure (23)

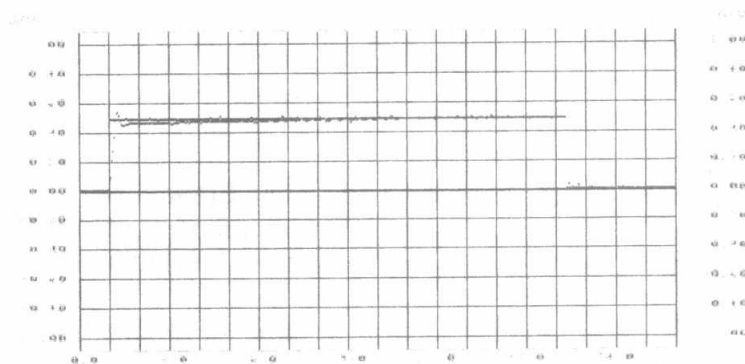

Fig (24)  
The output response and the reference input of the system with digital controller

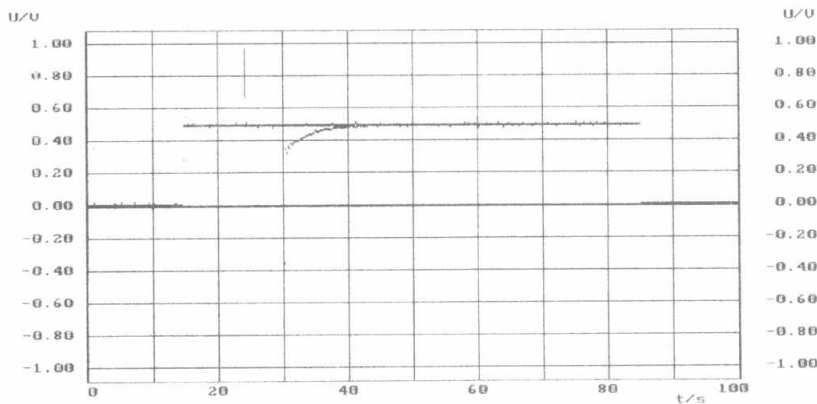

Figure (25)

The output response and the reference input when the system is subjected to step input disturbance

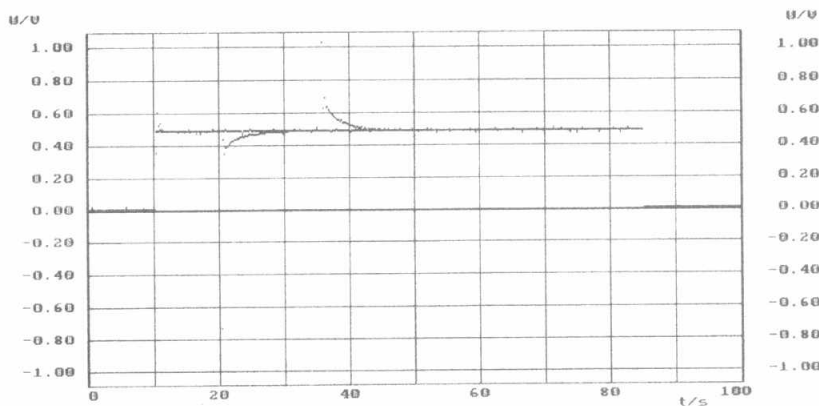

Figure (26)

The output response and the reference input when the system is subjected to pulse input disturbance

## 6- CONCLUSION:

The results obtained from this work show that better response specifications are obtained when implement a digital controller. Moreover the capability to change the control program (controller characteristics) is easily done when needed. Finally, digital controllers are superior to the corresponding analog controller from the viewpoint of internal noise and drift effects.

## REFERENCES:

- [1] Gene. F. Franklin, J. David Powell, and Abbas Emami-Naeini, "Feedback control of dynamic systems", Addison-Wesley publishing company, Inc., (1986).
- [2] Katsuhiko Ogata, "Discrete-time control systems", Prentice-hall international, Inc., (1995).
- [3] Benjamin C. Kuo, "automatic control systems", Prentice-hall international, Inc., (1995).
- [4] "Control system toolbox for use with matlab", The math work Inc., (1996).
- [5] "Simulink – dynamic system simulation for matlab", math work Inc., (1997).