

## **PERFORMANCE OF DEVELOPED PLANTING AND HARVESTING SUGAR BEET MACHINE**

**Elbanna E.B. ; Z. I. Ismail and A. E. Abou El-Magd**  
Agric. Engng Dept., Fac. Of Agric., Mansoura Univ.

### **ABSTRACT**

Authors were developed a planting and harvesting sugar beet machine. The machine was constructed to plant two rows and harvested one row. The planting mechanism was used brush metric device while the pulling and topping were the function of harvesting mechanism. The main goal of the present research is to test and evaluate the developed sugar beet machine performance. Operation costs for sugar beet planting and harvesting and to be suitable for the Egyptian farm conditions. The developing machine performance can be summarized as:

Planting mechanism was used to plant two rows of sugar seeds' and within planting operation formed three furrows using three shares of double mouldboard. The planting mechanism is brush wheel metric device. The machine capacity is one Fed./hr with total cost of 60 LE./Fed. .

Pulling mechanism is involved three main sugar beet harvester components namely, two appropriate shares for loosening the ridge structure around the roots, pulling out belt and a proper disk knife as a topping mechanism. Two opposite belts were constructed to push on leaves and pulling sugar roots and topping the leaves before crop was dropped on land surface. The machine harvesting capacity was 0.5 Fed/ hr, and total harvesting cost was 200-300 LE/hr.

The machine proper conditional performance were: Forward speed in both planting and harvesting operations were 1.5-2 km/h, and a 50-65 tractor can be used to operate the machine in both planting and harvesting operations.

### **INTRODUCTION**

The second major root crop grown in Egypt is sugar beet not only for sugar production, but also for producing animal fodder, and organic matter for fertilizing the soil. Over 40% of the world sugar production is produced from sugar beet. In Egypt the importance of this crop as a source of sugar was increased to meet the increasing consumption of sugar by Egyptian population. Therefore cultivated area of sugar beet increased from 190,000 to 200,000 Feddans, from 2003 to 2004, (Anon, 2004)

In fact harvesting sugar beet crop in the developing countries especially in Egypt are often performed by using simple diggers and manual tools. So harvesting operation can be an expensive labor-consuming if not properly mechanized, (El-Sherief 1996). Hence, application of a developed sugar beet harvester becomes one of the most essential targets for minimizing both, production cost, and root damage. Subsequently, increasing the net income for sugar beet growers in Egypt.

The range of the available harvesters all over the world may be included in three main harvester techniques namely: bulk, vibrating, and pulling, harvester techniques. Whatever the harvester classification, it has to lift the sugar beet crop, out of the ridge and by passing them through different sections of the implement to separate them from loose soil, soil clods, tops

and any other rubbish. Also whatever type of harvester is used, the same general principles apply when it comes to setting and using it. Whereas, the harvester should be directed so that it lines up correctly with the row of sugar beet crop to be lifted. This will normally be when the center point of any lifting

Finally confiding that rationalized power requirement, and minimizing both operation cost and beet damage are the umpires goals of developing sugar beet harvester in Egypt. Hence the aim of the present study is to test and evaluate the developed an economical planting and pulling out sugar beet harvester. The suggested harvester was planned to perform these subsequence functions: (1) losing the ridge around the growing roots, (2) pulling the bulk of leave cervixes to lift the roots from the ridge with its leaves and vines, (3) Topping the leaves, and then (4) Directing the roots back to the ground surface to be picked up by hand.

An additional aim has been realized through studying: (a) measuring the physical and mechanical properties of both plant portions (especially seeds, growing roots, leave cervixes), and the soil strength surrounded the root portion directly before harvesting time.

### REVIEW OF LITRERATURE REVIEW

Lebicki and Zong (1983) indicated that matching and adapting the design and the operating parameters of a vibrating mechanism is a main problem that exist when harvesting sugar beet by an implement excluding a vibrating mechanism. Hence, they carried out a theoretical analysis to derive the theoretical relationships which correlated the design and the operating parameters of a vibrating mechanism which is shown in Figure (1). They correlate the relationships between the inclination angle of the blade ( $\alpha$ ), the rotational speed of the vibrating mechanism ( $\omega$ ), the forward speed ( $V_m$ ), the distance between the front edge of the blade and the suspending point ( $L_1$ ) as shown in fig which is the ratio between the crank radius to the oscillating radius ( $\lambda=r/R$ ).Hence they derived the following relationship between the above mentioned parameters;

$$\omega \text{ max.} = \lambda L_1 V_m \alpha_0 / \lambda L_1 \text{----- (1)}$$

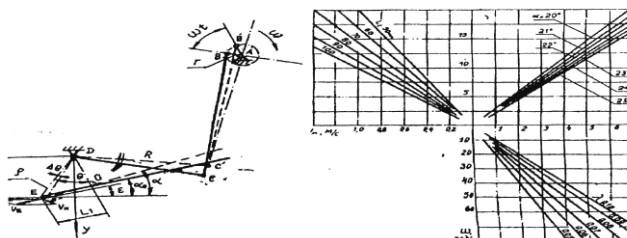

**Fig (1): Optimization of the relation ship between the design and the operating parameters of a vibrating mechanism (Lebicki and Zong (1983)**

Srivastava *et al.* (1995) cleared that the pulling mechanism in Fig. (2-B) is the common for harvesting the sugar beet crop. They showed that it has

two important implemented functions. Top removal is desired at the lowest point on the plant with respect to the top of the harvested roots. They added that interior surface (2) of the elevating part (1) grasp and continues to elevate the crop until the top portion of the sugar beet crop engages the counter-rotating toppers (3). This counter-rotation of the topper elements further ensures that the top of the plant is pulled up to the desired height.

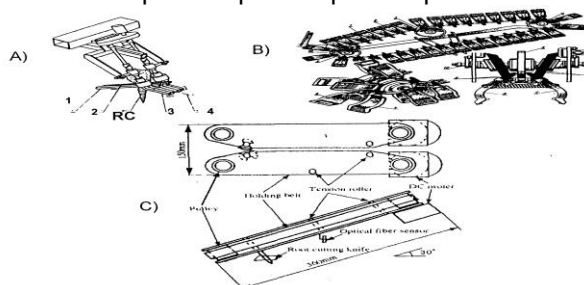

**Fig. (2): Three pullers mechanism versions for harvesting root-crops A) for Carrot harvesting B) for beet harvesting C) for the potherbs harvesting (Srivastava *et al.* (1995).**

Lebicki (1987) reported that the pulling techniques are suitable method to be used for harvesting beets for sugar. He mentioned that introducing the puller mechanism that shown in Fig. (3-B) started the movement towards that technique. He showed that the number of picking units on the shown mechanism is depending on the distance between the plants and the operated speed of the driven. the pulling units are traveled in a circular path opposite to the machine travel As a pulling unit is passed over grips engages around the beet to pick it. Then they grasp and elevate it by the continual rotating action. With further movement the crop tuber passes the pulling mechanism until the grippers is opened. Hence the beet crop is either thrown on the ground surface or ejected to a transport mean. The gripping spring mechanism must be opened and closed in the proper time.

Jolliet (1993) mentioned that there are two other versions of the pulling mechanisms which might be used for pulling sugar beet crop. These are the rubber belt and the pneumatic wheeled puller. He reported that the belt machine has two sets of belts per row. The pair of belts is arranged down the row with the driving shaft vertical. The front end is funnel shaped to allow the haulm to be gripped between the spring-loaded belts. The belts run backwards faster than the forward speed of the tractor, thus gripping, pulling and discarding the haulm at the back. He added that the wheeled puller has two pneumatic wheels per row; the wheels are on almost vertical driven shafts angled forward with the wheels in contact. Haulm feeds between the wheels, which run backwards faster than forward speed; the haulm is gripped, pulled and discarded.

Keppner *et al.* (1982) stated that, machine witch lifts the un-topped beets as they are plowed loose, either by gripping their top growth or by impaling the beets on a spiked wheel. The beets are lifted free of the soil and the problem of separating the roots from large clods occurs in heavy soils is

eliminated. The beets are topped in the machine after being elevated. Machines that lift the beets by their tops have a pair of inclined chains or belts, held together with spring-loaded idler, which grips the beet root when blade cuts the top of roots and loosens the soil. Harvesters of this type can be used only under conditions where the tops have adequate strength to support the weight of root. the plant portion the two

Lovergrove (1968) indicated that, a machine which picks the whole beet from the ground with its top, and lifts it to a topping mechanism, where it is away from the soil and the stones which may damage the knives of topping units mounted in the more orthodox position. the beets are loosened in the ground by a share or pair of tines, while at the same time, their tops are gripped at the base of the foliage between two rubber conveying belts which lift the entire beet to the topper unit. At the end of their travel, the beets are lined up by adjustable guides with two rotating topping lifter wheels, and as the cut is made the roots fall into the hopper or elevator, while the tops are lifted into another. This type of machine can work at a relatively high speed, although consistency of topping depends upon reasonably strong top foliage.

Vermeulen (1997) determined the lifting of sugar beet out of the ground with different movements and at different speeds, and the amount of soil adhering to. The beet were either pulled straight up at vertical speeds of 0.3, 0.7 and 1.5 m/s, or at the same vertical speeds but with a slight or a strong twisting movement (requiring 0.77 m or 0.35 m respectively for one complete rotation). The results showed clearly that soil decreased when increasing rotary pull (twist) was imparted to the beet.

Lebicki (1987) reported that most topping mechanisms can be operated as individual topping machine or mounted on its own harvester. Most of such machines in use now are tractor-mounted or semi-mounted and operated by the power take-off (P.T.O.) as shown in Fig (3-a). These types are suitable for row widths from 650 mm to 900 mm. They are made to fit cut the contours of the bed row as shown in Fig (3b). The flail toppers Fig 3C), often has flail vertical type knives, and full width adjustable gage roller located at immediately behind the rotor to provide cutting heights control.

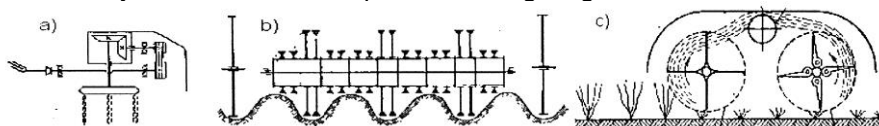

**Fig. (3): The operating principles of the toppers (Lebicki (1987))**

Smith and Wickers (1994) reported that over the recent years a number of toppers and under root cutters have been designed and developed on the same design principles of the rotary beaters, or flail of forage harvesters. They concluded that the machine which is equipped with pair of rotary cutters reduces the overall labor requirements to a great extent. That is because pair of rotary cutters rotates opposite each others. Thus it deposits the vegetative in a narrow row in the field. Fig (4) shows the available features of topping mechanisms

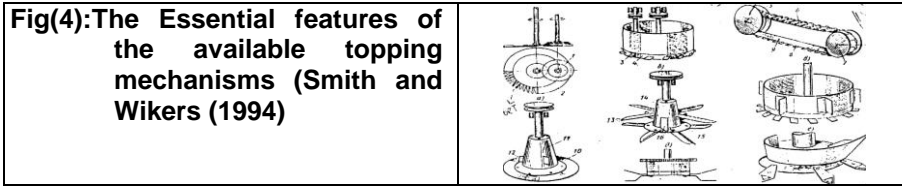

It can be seen that most of them are rotary toppers, which have high-speed disc, and/or drum. They added that, the rotary cutters or pasture clipper equipped with gage wheels does a good job of shaving off the tops of the bed row. But the success in performing topping is depending on the matching between of the vegetative properties, and each of number, diameter, and revolution speed of topping mechanism.

Bzowska-Bakalarz (1999) tested one-stage sugar beet harvesting for its operating performance. Characterization and localization of root damage were examined on 2 sugar beet cultivars, in spite of unsuitable harvesting conditions (rainfall, high soil moisture content, low soil compaction, and protruding roots), the quality of the harvested crop was satisfactory. However, the quantities of serious root damage, as well as the roots being topped too high, slightly exceeded the allowable standards. The tested beet harvester provided satisfactory cleaning (6% impurities in total). The investigations determined the 13 zones of root damage most frequently occurring during mechanized beet harvesting.

Bulhakow et al (2003) found that the motion of a soil layer with sugar beet roots in the surfaces of a pair of flat, oblique shares was analyzed. During the last phase of this motion, a beet root directly contacts the planes of the shares. The influence of share position angles onto the machine maximum allowable forward velocity was defined at which, in particular soil conditions, the end part of the root would not be broken and left in the soil. Assuming the value of the vertical force binding the beet root with the soil as 0.2 kN and unitary resistance of soil already loosened by shares as 2.0 kN m<sup>2</sup> and taking the apex angle of the beet root come as 20-28 degrees, the highest value of the machine velocity limit may be achieved when the angle 2γ of the divergence of shares will be kept between 26 and 32 degrees and the angle β of deflection of share plane from vertical will be 30 degrees.

Mohamed (1998) mentioned that the maximum force needed to cut the beet in the upper part was 540 N the middle part 430 N and the root part was 188 N. Also, by increasing the beet diameter from 6 to 15.6 cm the hardness increased from 4.09 to 6.02 N /mm. By the cutting resistance were 11.11, 22.22 and 166.67 N/mm at sharpness values of 0, 0.5 and 1 mm respectively. The cutting power required ranged between 0.71 to 1.34 kW and the cutting energy ranged between 4 to 9.28 N.m

Determinations of the shape and dimensions of the sugar beet crop ridge at time of harvesting allow for tractors and harvesting machines to securely travel between the rows to harvest without causing damage for the crop. Abou Elmagd (2001) indicated that to detect of the geometric of the root crop ridge, the measurements should be run in the two perpendicular

directions of the ridge. The lateral direction is considered as X-axis, and the ridge height as Y-axis. That measure should be done for hilled and non- hilled zones.

From that point of view the locally made, ridge drawing profile-meter which is

However, Elbanna (2001) found a general relationship between, cone index, proctor needle and vane shear reading as:

**Cone index = 10\* vane shear readings and Proctor needle = 1.5 \* cone index**

The three readings of these instruments can be calculated using the cone penetrometer equation (Elbanna, 2001) as in the form:

$$CI = [3.62Cr_e^{-0.010(1+Cr)} + 0.0066 \frac{\gamma}{(1 + 2Cr)}] e^{\pi \tan \phi}$$

where  $\theta$ = soil content, %;  $\phi$ = soil internal friction angle;  $\gamma$ =soil specific weight, kN/m<sup>3</sup>;

**Cr= %clay/(% silt+sand). and  $\tan^{-1}\phi= 1/(1+2Cr)$ .**

## MATERIALS AND METHODS

**The developing machine components (Elbanna, et al. (2010) can be summarized in two parts:**

**First component:** is planting unit: this unit is planting two sugar seeds' rows with suitable depth at top of the middle center of the two furrows, in the same time formed three cultivable rows. The formed three shares are seated after the two planting rows. Each formed row share is a consisted from a double mouldboard bottoms, at end of it whereas, the drop seeds is covered by the sliding soils path.

**Second Component is sugar beet pulling unit:** this unit is involved three main sugar beet harvester components namely, two appropriate shares for loosing the ridge structure around the roots, pulling out belt mechanism with its proper power transmission system, and a proper disk knife topping mechanism.

**Planting and Harvesting/ Date:** the planting season begins in September and continues until mid-October. Harvest starts roughly April 15 and ideally ends by the 1st of August. Late-planted fields tend to be more expensive due to additional costs for irrigation, additional pest control, and for losses due to root rots and sugar beet cyst nematode. However, sometimes the greater expenses on late fields are often offset by higher beet yields.

The main technical components (planting and harvesting units), and each unit parts can be described, in general parts e.g. Frame, hitching system and transpiration power unit, and two machine components (e.g. Seeding and harvesting mechanisms), as are explained in Fig. (5a, b and c) by Elbanna, et al. (2010).

Planting mechanism is involved seed tank, seed device (wheel brush) and seed tubes, Fig. 5a and b. The harvester mechanism included four main units namely: pulling unit, rarefaction unit, topping unit, and transmission systems, (Fig 5a and c).It can be noticed that all planting and harvesting parts are carried on the main frame also and other parts e.g the hitching system, and the tracing wheel system.

**Planting unit:** Fig. 6 shows the seed boxes while Fig. 7 is shown diagrammatically a brush-type (sowing device). The sheet-iron bottom of the box has rectangular openings, and underneath is a strip with round orifices which can be manually shifted along the box axis and which serves to control the rate of seeding.

**Seed tubes:** A telescopic plastic tubes 2.5 cm inner diameter and 45 cm length were used to drop seeds from metric devices into the top of opener furrows, the end of bottom tube fitted in a device which is formed from a two 6 cm lateral iron plates and a 7.5 cylinder to prevent seed scatters.

**General Parts:** Planting and harvesting developed machine mechanism was explained and shown in Elbanna, *et al.* (2010). That machine was shown in Fig. 5.

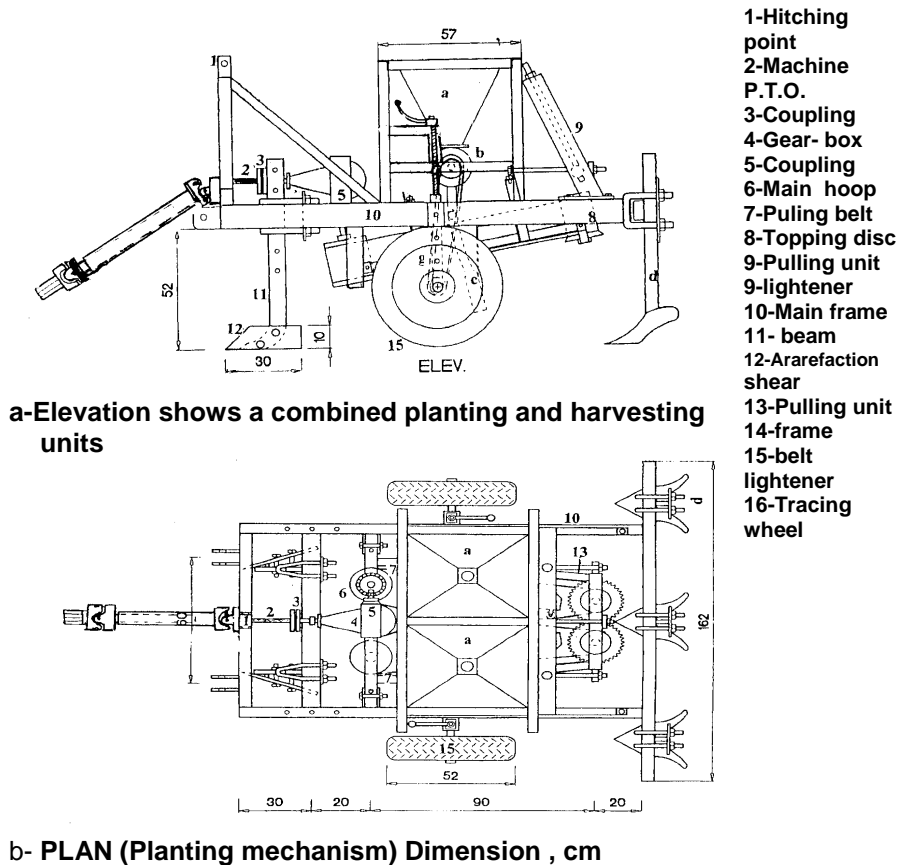

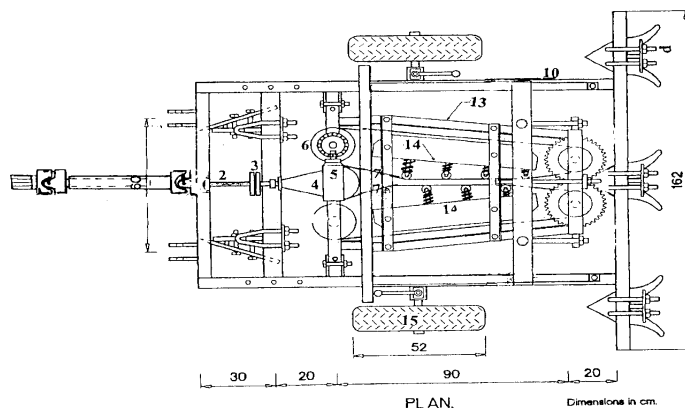

c-Plan shows harvester mechanism

**Fig. (5):** Sketched of elevation and plan views of the developed planting and harvester sugar beet machine.

**Forming furrows' shares:** A three forming shares were constructed from a double a small mouldboard bodies. Each wide share has 3 cm at its top end and 15 cm wide ends has formed from two mouldboard. The formed share dimension is suited to make 3 furrows with 60-70 cm spacing in between Whereas, each share ridged the furrows bottom and both its mouldboard moves the soil 20 cm in each side of that furrows to form a wide furrows. At the end of each mouldboard path whereas seeds dropped in the top center of that furrows, where a little of the moving soil is covered the sugar beet seeds.



**Fig (6) Constructed seeds box**

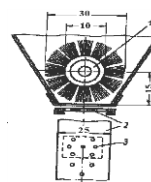

1-brush roller; 2-siding plate for adjusting the rate of seeding; 3- openings releasing seeds

**Fig. (7):**A brush-type device for sowing small seeds:

**Harvesting Unit:** was consists from four main units namely: pulling unit, rarefaction unit, topping unit, and transmission systems. It also includes three secondary units such as the main frame, the hitching system, and the tracing wheel system, (Fig. 5a and c).

**Pulling unit:** the puling unit was built and constructed locally according to the theoretical relationship and fitted to the developed harvester. It made from steel sheet and fixed on the machine frame. The pulling unit consists of three main parts fixed on especial frame:



**a- Pulling belt:** Uprooting sugar beet in the present research is performed by picking up plant leaves in small gap between two parallel arranged gripping belts. The using pulling belt consists of two wings (Fig (8)). Each wing is of 250 cm length, and of 15 cm width. The belt constructed as (V) shape and covered with especial material to increase coefficient of friction between leaves and belt.

**Fig. 8: Illustrates schematic of the main parts and operations consecution of developed pulling mechanism. It shows that the pulling belts are sat at a certain small angle ( $\alpha$ ) with respect to the horizontal, and at a certain aperture angle ( $2\beta^\circ$ ) in relation to the direction of machine travel.**

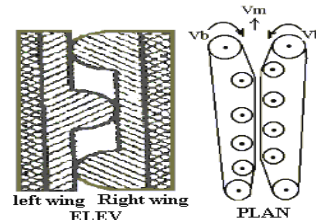
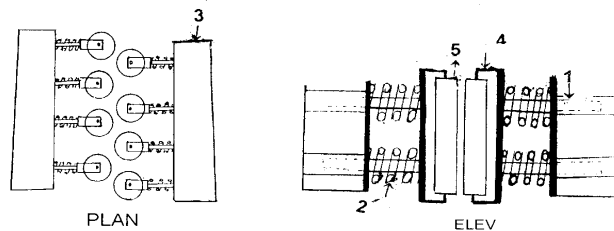

**Fig (8) Pulling belt.**

**b- Hoops group:** the hoops group was used to revolving the pulling belt, and it consists of four hoops, two with diameter of 17.5 cm and height of 20 cm fixed on shaft of 2.5 cm diameter and 40 cm length. The right shaft connected with gear-box by coupling. The other two hoops with diameter of 12.5 cm and height of 20 cm fixed on the back. The distance between the axis of the front and back hoops is 90 cm. When the universal joint is engaged between tractor P.T.O. shaft and gearbox shaft the motion transmit from gearbox to the right front hoop and consequently to the wing of right belt and by using gear fixed on the top shaft of the back hoop the motion can transmit to the lift belt wing.

**c- Pulling tightened deliver:** The tightened unit was used to control of pulling belt tightness. It consists from 8 hoops with lengths of 15 cm and diameter of 5 cm contact with the belt and two cases steel U shape 10 x 10 x 0.4 cm and with length of 80 cm contend springs and its shaft as shown in Fig. (9).

Due to the combination of belt peripheral ( $V_b$ ) motion and the forward speed ( $V_m$ ) of the harvester, the punches of plant leaves are directed to the zone where the two belts are closely pressed together on them by means of two clamp spring sets, each consists of eight springs.



**1-Shaft spring; 2-Spring; 3-Case steel; 4-Hoop bearer; 5-Hoop**  
**Fig. (9) Pulling tightened.**

The previous parts are assembled on both puller belt mechanism sides and behind the belts along a distance of 80cm each spring was 10 cm length and 3 cm diameter and having stiffness coefficient of about 0.4 N/cm. These clamp spring sets are used to keep the two belts at the desired tension and gap clearances required for pulling up the plant. The desired tension and gap clearances between the two belts were adjusted by means of tighten box and guide, as illustrated in Fig. (9).

**Rarefaction unit, (Fig. 10):**

The rarefaction unit were manufactured for loosen the bonds between soil and beet root surface (at front of the frame) by pulverizing both ridge sides. These units consists of two shears as shown in Fig. 6 of 8 cm height with base of 33 cm and top of 23 cm and it fixed in the two beam which move on a pare of 5x5 cm to control of the rarefaction distance ( $d_r$ ) between the two shears.

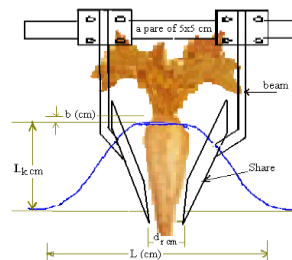

**Fig . 10 A rarefaction shear**

While, the control of the rarefaction depth was done by using two tracing wheels (with diameter of 30 cm) fixed with two guides, by these guides, it can be controlled the rarefaction depth by increasing or decreasing the guide height. The lower ends of two shears are shaped in a certain wedge form and assembled on the machine frame to help in guiding the up ground plant portion to enter the gripping zone.

**Topping unit:** Topping of sugar beets in the present research was selected to be performed to the picked up whole plant (after pulling). The topper mechanism is mainly consists of two topping disks each of the same diameter ( $D'$ ). These disks are mounted below the rear idler belt pulleys as shown in Fig (11). These disks are rotated opposite to each other, in a plane that is perpendicular to the plane of the belt motion. To ensure proper topping (cut of the upper plant portion), it was regarded that the two disks is transmitted its motion from the same power source of the belts by means of pulleys and belts. Whereas, the linear speed of these disks was regarded to be 1.25 times the belt speed.

This pair of discs were used to topping sugar beet plant one pair is smooth disc, whilst the other is toothed disc. These units made from iron steel with thickness of 5 mm and serrated diameter of 230 mm the clearance (H) between the two discs ranged from 1 to 2 cm. The rotational speed of these units is changed with the change of belt speed. The disc speed was 1.25, 1.6 and 1.9 m/s.

**Power transmission system**

The developed harvester is a semi-mounted machine. Its transmission system was designed to give the same ratios from tractor to the pulling belt. The designed transmission system is shown in Fig (12). It consists of gear-box, main hoops, rear hoop, two gears, and puling belts

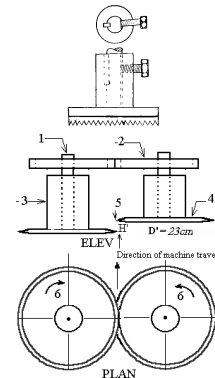

1- Shaft; 2- Gear; 3- Hoop; 4- disc; 5- disc clearance; 6- disc move direction

**Fig. (11): Topping unit**

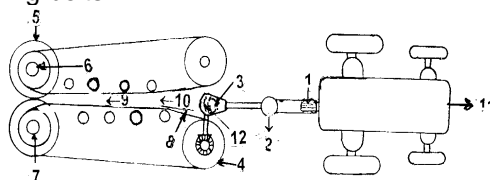

1-Tractor P.T.O.; 2-A universal joint 3-Gear- box; 4-Main hoop 5-Gear; 6-Rear hoop 7-Hoop shaft; 8-Pulling belts 9-Motion direction; 10-Gripping zone 11-Tractor motion direction 12-Shift coupling

**Fig. (12): Transmission system of the developed harvester.**

**RESULTS AND DISCUSSION**

**Seeding rate:**

sugar beets are grown single line on 60 cm rows. Some early season fields are planted at a 5 to 7.5 cm spacing; later fields are precision planted with seed spaced 10 to 15 cm apart. Seed is now sold in units of 100,000 seeds. Seeds prices depend upon fungicide and insecticide treatments, seed size, seed quality, variety and quick prime treatment. Precision planting improves the overall stand by reducing the need for thinning and increases overall plant uniformity and population.

Field observations indicate that yield is reduced more by too few plants than too many plants per Fed. Planting depth is normally 0.6 to 1.25 cm. Many kinds of planters are used including vacuum planters. Early plantings during extremely hot weather will require a higher seeding rate to achieve the proper stand. Planting when soil temperatures are high greatly increases the incidence of seed rot, damping-off and insect injury. However, new seed treatments have reduced the problem significantly.

**Soil properties and ridge profile:**

Soil strength (cone penetrometer), soil specific weight and moisture content were measured before the planting and harvesting days. All field experimental tests were carried out at 75-village Kafr El-Sheikh Governorate and El-Serow, Domitta, Goveronrate. whereas, soil textures was clay loam

and clay soils. Most of that areas were grown sugar beet crop yearly, the soil mechanical analysis and its properties are given by Elbanna *et al.* (2010). Tables (1a and b) showed soil properties, soil strength forces at the the day before planting and harvesting

**Table 1a: 75-Village, El-Hamool and El-Serow soil mechanical analysis**

Site	Sand, %			Silt, %	Clay, %	C <sub>r</sub> ,	φ, deg
	Coarse	Fine	Total				
75-Village	4.95	10.48	15.43	30.77	53.80	1.165	16.70
El-Serow	1.55	8.95	10.50	27.12	62.38	1.658	14.25

**Table 1b: Average values of soil strength (measured with cone penetrometer) soil moisture content and specific weight at the previous day of planting and harvesting (Cr=1.165 clay loam).**

Profile depth, cm	Soil specific weight, kN/m <sup>3</sup>	Soil moisture content, %		Cone index, MPa,	
		Planting day	Harvesting day	Before:Planting day	Harvesting day
5	14.04	26.02	23.02	1.449	1.955
10	13.99	27.04	22.04	1.487	2.135
15	13.64	27.60	23.60	1.509	2607
20	13.44	28.50	24.50	1.559	2.405
25	14.07	28.54	25.54	1.561	2.514
30	13.84	29.23	25.9	1.513	2.133

Same values in tables 3.1b +10% increases were record at El-Serow clayey soil .

Tables 2 to 7 and Figs 13 and 14 reveal the physical and mechanical properties of sugar beet root leaves before harvesting at clay loam and clay soils. Pulling force required with and without rarefaction as an average all of 100 randomized samples with other. Finally, Factor affected ridge refraction performance and topping and up-topping sugar beet roots and leaves.

**Pulling force:**

The predicted pulling force involved:

- 1-The proper vertical pulling force;
- 2-The proper inclined pulling force;
- 3-The proper parameters of soil loosen;
- 4-Proper feeding and orienting leaves punch;
- 5-Proper conditions of gripping and pulling the leaf punch

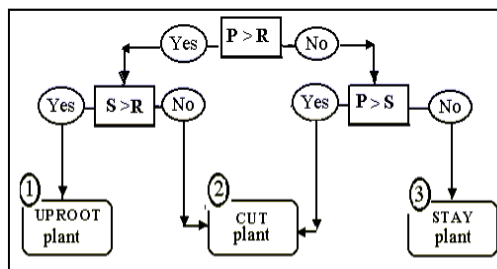

The possible alternatives when applying a force (P) to uproot an individual beet plant

P= applied pulling force.

R= soil resistance to loose the soil /beet adhesion bonds

S=cutting resistance of above ground plant portions

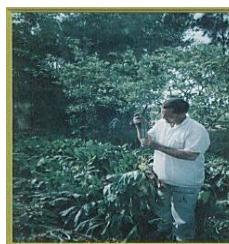
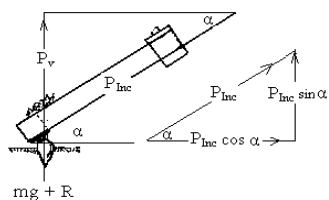

Table 2: Physical and mechanical properties of sugar beet root before harvesting at clay loam and clay soils

100 Samples	Pull force, N without A*	Pull force, N with A*	Decr., %	Mass, kg	Length, cm	Diam.**, cm	Surface Area, cm <sup>2</sup>	Adhesion, N/cm <sup>2</sup>	Root Volume cm <sup>3</sup>	Real Denisty g/cm <sup>3</sup>
<b>Clay loam soil</b>										
Ave.	437.3	329.2	24.8	1.75	29.5	12.8	592.8	1.18	1104	1.34
Sd.	45.8	40.5	3.9	0.39	3.0	0.84	68.2	0.18	192	0.35
<b>Clay soil</b>										
Ave.	701.42	510.6	27.2	1.66	24.7	11.7	451.8	0.98	1085	1.49
s.d.	79.55	61.10	2.32	0.4	2.8	0.9	43.0	0.2	139	0.4

A\* = A rarefaction \*\*\*\*\* \*\* = Maximum diameter

Table 3: Physical and mechanical properties of sugar beet leaves Before harvesting at clay loam and clay soils.

100 Samples	Leaves cutting force, N	cutting height, cm	Leaves height, cm	Leaves number	Knife height, cm	Leaves Weight, N
<b>Clay loam soil</b>						
aver	2155	12.0	47.0	29.5	21.7	13.0
Sd.	90.1	1.3	4.8	4.3	2.6	2.5
<b>Clay loam</b>						
Aver.	2192	11.5	45.5	28.5	29.6	12.9
Sd.	67.4	1.3	4.8	4.3	3.1	2.5

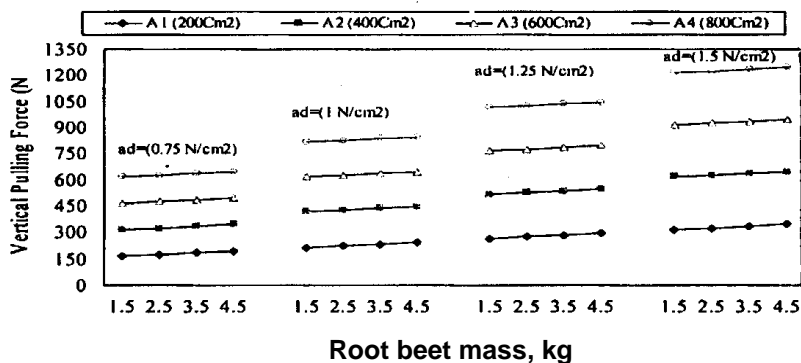

Fig. (13): Prediction of vertical pulling force for pulling different roots mass with various surface areas at different soil adhesion conditions.

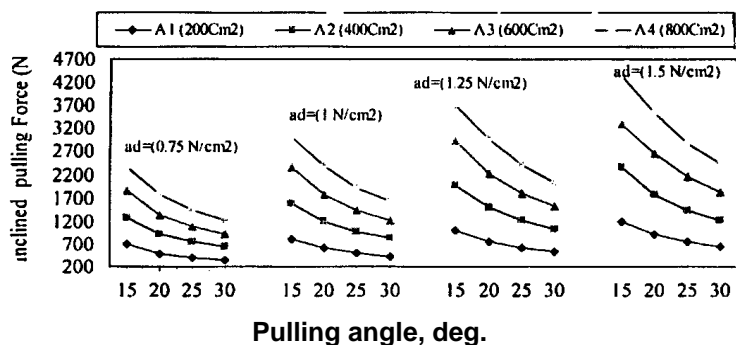

Fig. (14): Prediction of inclined pulling force for pulling different roots surface areas at different soil adhesion conditions.

Table 4: The ridge refraction performances as affected by travel speed (Vm), and space between the bottom edges of rarefaction shares (dr).

Studied vari		Evaluating Parameters							
dr (cm)	Vm (m/s)	Clay soil				Clay loam soil			
		Root damage %	Manual pulling force			Root damage %	Manual pulling force		
			pulling force(kN)	Root mass(kg)	P/M (Kk/kg)		Pulling, P force(kN)	Root mass(kg)	P/M (kN/kg)
15	0.83	16.90	0.4459	2.35	0.190	12.60	0.3577	1.75	0.204
	0.97	18.25	0.4704	2.25	0.209	13.90	0.3724	1.85	0.201
	1.11	18.83	0.4900	2.35	0.209	15.80	0.3920	1.90	0.206
	1.25	20.50	0.5096	2.50	0.204	15.42	0.4067	2.00	0.203
Average		16.95	0.4790	2.36	0.203	16.03	0.3822	1.875	0.204
20	0.83	12.60	0.5023	2.50	0.201	10.70	0.3969	2.00	0.198
	0.97	14.10	0.5341	2.65	0.202	11.60	0.4214	1.85	0.228
	1.11	14.20	0.5439	2.50	0.218	12.60	0.4386	2.15	0.204
	1.25	15.58	0.5586	2.25	0.248	13.20	0.4557	2.25	0.202
Average		13.71	0.5347	2.48	0.217	12.76	0.4281	2.06	0.208
25	0.83	8.10	0.5366	2.50	0.215	5.89	0.4239	1.65	0.257
	0.97	9.50	0.5537	2.35	0.236	6.74	0.4386	1.75	0.250
	1.11	10.30	0.5684	2.50	0.227	7.33	0.4508	1.85	0.243
	1.25	11.80	0.5733	2.75	0.208	8.60	0.4557	2.25	0.202
Average		8.43	0.5580	2.525	0.222	7.47	0.4422	1.875	0.238
30	0.83	7.10	0.5831	2.75	0.212	4.60	0.4582	2.25	0.203
	0.97	7.90	0.5880	2.50	0.235	5.00	0.4655	2.25	0.207
	1.11	9.30	0.6174	2.80	0.221	6.15	0.4876	1.75	0.278
	1.25	9.60	0.6395	2.45	0.261	6.70	0.5047	2.25	0.224
Average		6.9	0.61	2.625	0.232	6.1	0.48	2.125	0.228

**Table 5: The mechanical performances as affected by traveling speed (Vm), and space between the bottom edges of rarefaction shares (dr) at Clay loam soil.**

Studied variables	Measurements					Evaluating Parameters			
	V <sub>m</sub> , m (dr,cm)	draft force (kN)	draft force +RR	Slip %	Fuel (L/h)	Slip effort (kN)	Total effort (kN)	Traction power (kw)	specific fuel (L/kW)
1 (15)	7.43	7.56	18.51	2.86	1.42	8.97	9.47	0.30	2.58
1 (20)	7.26	7.39	17.28	2.73	1.29	8.68	9.17	0.30	2.89
1 (25)	6.57	6.70	16.50	2.52	1.13	7.83	8.34	0.30	3.29
1 (30)	6.33	6.46	15.06	2.38	0.99	7.45	7.90	0.30	3.36
Total	6.90	7.02	16.84	2.62	1.21	8.23	8.72	0.30	3.03

**Table 6: The ridge refraction performances as affected by travel speed (Vm), and space between the bottom edges of rarefaction shares (dr).**

Studied variables	Evaluating Parameters of Clay soil			
	V <sub>m</sub> , m (dr, cm)	Root damage, %	Manual pulling force	
			pulling force, kN	Root mass, kg
1 (15)	16.95	0.4790	2.35	0.205
1 (20)	13.71	0.5347	2.50	0.209
1 (25)	8.43	0.5580	2.50	0.220
1 (30)	6.9	0.61	2.65	0.235

**Table 7: The beet uprooting process as affected by speed ratio SR (between belt speed to tractor speed), and belt inclination angle (α), at clay loam soil**

Studied variables		Evaluating parameters			
α, degree	S R	Lifting, %	Capacity, (t/h)	Fuel ,(L/h)	Power (kw)
20	1	73.84	14.09	1.90	4.67
	1.25	77.30	15.72	1.65	4.50
	1.5	78.59	19.01	1.40	4.10
	1.75	80.21	19.24	1.23	3.75
Average		77.48	17.01	1.55	4.25
25	1	77.57	14.72	1.75	3.77
	1.25	79.40	16.42	1.50	3.64
	1.5	80.74	19.86	1.30	3.31
	1.75	83.33	20.10	1.25	3.03
Average		80.26	17.78	1.45	3.44
30	1	77.32	15.83	1.50	3.20
	1.25	79.16	17.66	1.35	3.10
	1.5	83.5	21.4	1.3	2.8
	1.75	82.10	21.61	1.00	2.57
Average		80.52	19.11	1.28	2.92

**Conclusion**

An Economical sugar beet planting and harvesting machine performance was tested and evaluated to a rationalized power, and operation cost combined and to be suitable for the Egyptian farm to replace the traditional methods in both planting harvesting operations. The developed

machine has two components: first component is planting unit: which involves two seeder rows with suitable depth at top of the middle center of the two rows. machine performed 60-70 cm ridges during planting two rows, each is consists from two small opposite mouldboard bottoms. One furrow was fitted on the front frame as primary share moving soil in both sides and the other two shares seated after the two planting rows at back of the machine frame to completed the two formed rows and covering the dropping seeds. The machine planting performance: 1 Fed/hr, cost 60LE/Fed, at 3-4 km/hr with deviation in seedling from center row of 3-10% and uniformity of seeding 90-97% using a brush wheel metric seeding device.

**Performance of harvesting unit:** this unit involves sugar beet pulling out belt mechanism; A rarefaction unit consist of two appropriate shares for loosing the ridge structure around the roots and a proper disk knife as a topping mechanism. All these components were equipped on a proper mounted one-row harvester frame. Field experiments were carried out to test and evaluate the performance efficiency of the developed harvesting machine unit under different operating parameters and conditions. The performance of harvesting sugar beet unit 0.50 Fed/hr (200-300LE/Fed) at different forward speeds (from 0.5 to 1 m/s) with 85-95% pulling efficiency and 4-11% roots damage with pulling force of 437, 329 and 701, 510 N without and with rarefaction unit for clay loam and clay soils (at roots characteristics of: 29.5 and 25.7 cm length; 1.75 and 1.66 kg mass; 12 and 11.7 cm diameter; 592.5 and 452 cm<sup>2</sup> surface areas and an average roots mass of 1.75 and 1.66kg, and leaves cutting force of 2155 and 2192 N, respectively at clay loam and clay soils, the proper pulling angle was 30° at various soil adhesion from (0.75 to 1.5 N/cm around sugar beet roots) for two tested soils.

#### **Aknowledgement**

This work represents one of the out comes from the projects financed by Mansoura University researches unit (title: Development planting and harvesting sugar beet crop machine).

#### **REFFERENCES**

- Abou Elmagd A.E. (2002) Modern trends in harvesting root crops .State of art, Supreme council of universities (SCU) Frequent Scientific committee for Agric, Eng. Ain Shams Univ, Egypt.
- Abou Elmagd A.E.(2001) Potato tuber-soil mutual stress under different machinery treatments. J. Agric. Sci. Mansoura Univ., 26(12): 7953-7967.
- ASAE (1992). Agricultural machinery management EP3911, ASAE year book of standards. Joseph, At. MI 49085.
- Bulhakow-W; I- Golowacz; and A-Szeptycki; (2003) Theory of share digging unit in sugar beet harvesting machines. Acta-Scientiarum-Polonorum - Technica-Agraria, 2: 1, 67-74.
- Bzowska-Bakalarz -M (1999) Operation quality of a harvester for one-stage sugar beet harvesting. Problemy-Inzynierii-Rolniczej., 7: 1, 43-50.



- Elbanna, E. B. (2001) Comparative studies of three soil strength methods on sandy soils (Part I). J. Agric. Sci., Mansoura Univ. 26(12): 7929-7942.
- Elbanna, E.B. ; M. A. El-Saadany and N. Mansour (2010) Clay and heavy clay soils improvement water movement by application of sub-soiling methods. J. of Agric Soil Sci. & Engr. 8(2):
- Elbanna E.B.; Z. I. Ismail and A.E. Abou El-Magd (2010) Development planting and harvesting sugar beet crop machine. J. Agric soil Sci. and Engr, Mansoura Univ. 8(2):
- El-Sherif, R.R. (1996 ). A study on harvesting mechanization of Sugar beet - Unpubl. Ph.D.Thesis. Fac. of Agric., Kafr EL- Sheikh, Tanta Univ., Egypt. 85:90.
- Lebicki N. U. and Ch. D.Zong (1983) "Theoretical analysis for lifting a potato ridge using vibratory harvesting techniques" J. Mechanization of growing and harvesting crops. Vol.(113), Agric. Aka, of Gorke, BSSR,: 3-7 (In Russian)
- Lebicki N. U (1987) "The main parameters affecting root crop harvesters" J. Ag. Machinery & Tractors No 137. Paper of Belyrussian Institute of Ag. Mech. (BIMCX), Minisk, BCCR: 48-56 (In Russian).
- Lovergrove, H.T.(1968) Crop production equipment Hutchinson Tech .Ed. England
- Jolliet, O. (1993) Ecological balance of thermal, mechanical and chemical methods of destroying potato haulms". Landwirtschaft- Schweiz., 6: 11-12, 675-682.
- Kepner, R.A.; R. Baine and E.L Barger (1982) Principles of farm machinery, 2 nd Ed. CBS Publisher, Distributors, India, : 464-468.
- Mohamed, A.H.A. (1998). Design and development of a sugar beet topper. Ph.D.Thesis .Dept. of Agric.Mech., Faculty of Agriculture, Ain-Shams University.
- Smith A.E. and M. S, Wilkes (1994) " Farm machinery and equipment" Pre root harvesting equipment- McGraw-Hili Publication Company, L.T.D. New Delhi.363-377
- Srivastava A.K.; C. E. Goering; and R P. Rohrbach (1995). "Engineering principles of agricultural machines". American Society of Agric. Eng. Pe,mela DeVore-Hansen, Editor Books & Journals: 452-474.
- Vermeulen-GD (1997) Lifting and pulling sugar beet clean out of the ground. : Landbouwmechanisatie. 1997, 48: 2, 62-63.
- زارة الزراعة المصرية ، الجهاز المركزى للتعبيئة والاحصاء نشرة انتاج محصول البنجر (2004) Annon مرجع رقم 879.

**أداء الآلة المطورة لزراعة وحصاد محصول بنجر السكر  
الشحات بركات البنا ، زكريا إبراهيم إسماعيل وعلى السيد أبو المجد  
قسم الهندسة الزراعية – كلية الزراعة جامعة المنصورة**

تم تقدير أداء الآلة المطورة لزراعة خطين ببذور محصول بنجر السكر، وفي نفس الوقت حصاد خط واحد من محصور بنجر السكر في الجرة الواحدة لنفس الباحثين.

1- وحدة الزراعة ينصح باستخدام أقراص البذر ذات الفرشاه حيث من الإختبارات أعطت نتائج عالية بكفاءة زراعة 94-97% وتشتت 3-10% عن منتصف الخط، بالمقارنة بالعجلة ذات

الخلايا المحيطية التي أعطت نتائج منخفضة في إنتظام الزراعة أو كفاءة البذر لإنسداد الخلايا بالبذور الغير ملساء، والشئ الذى يحتاج المزيد من الدراسة هو فجاجات تشكيل الخطوط وتغطية بذور البنجر، حيث أنها تعمل على فج الخط بالفجاج المثبت فى منتصف إطار الآلة الأمامى وإزاحة الأتربة أمام أنابيب البذر ثم إكمال تشكيل الخطوط بالفجاجان المثبتان على الإطار الخلفى لتغطية البذور وإستكمال تشكيل الخطوط. أعطت فجاجات تشكيل خطوط أكثر انتظاما بالمقارنة بأى آلة زراعة أخرى بأبعاد 17-20 سم عمق، 60-70 سم مسافة بين الخطوط، وظهر الخط 10-15 سم، حيث يعمل الفجاج المثبت فى منتصف مقدمة الإطار على إزاحة الأتربة للخارج حيث تسقط البذور من أنبوتى البذور على الأتربة المزاحة، حيث يعمل الفجاجان المثبتان على الإطار من الخلف على تكملة تشكيل الخطوط بإزاحة الأتربة جزئيا لتغطية البذور بالخطين التى تم زراعتهما وإزاحة النصف الآخر للخارج للبدء فى تشكيل خيطان جديان... وهكذا. والفجاجات الثلاثة كل منها عبارة عن فجاج مشكل من مطرحتان لمحرث مطرعى مقدمة كل منها 3 سم وعرضه بالمؤخرة 20 سم.

**2- وحدة الحصاد:** تتكون من وحدة خلخلة التربة حول جذور البنجر عبارة سلاحان لمحرث حفار يستخدمان لخلخلة خط محصول البنجر لتسهيل عملية الملح (الشد)، وحدة الشد عبارة سيران عرض 12 سم مقويان بمادة معامل إحتكاك عالى، ينضغطان على بعضهما بمجموعة من السوست والبكرات، يقوم السيران بالقبض (الضغط على المجموع الخضرى للنبات) الذى تم خلخلة جذوره، ونتيجة تقدم الآلة للأمام يحدث ملح لجذور البنجر؛ وفى نهاية السير وحدة التطويش للمجموع الخضرى حيث يعمل زوج من السكاكين القرصة ذات الدوران العكسى بفصل المجموع الخضرى عن جذور.

تم تقدير القوى اللازمة للشد أو تقليب الجذور بمتوسط 3.29، 4.37 للتربة الطينية الطمية 5.10 ؛ 7.01 ك.نيوتن للتربة الطينية الثقيلة فى حالتى وجود وعدم فجاجات الخلخلة . وتقدير سعة الآلة عن مختلف السرعات الأمامية ونسبة سرعة السير إلى سرعة التقدم  $SR=1-1.75$  عند 4 زوايا شد مختلفة 15، 20، 25، 30 درجة وفضل ظروف تشغيلية لأستخدام الآلة هى : الآلة يمكن إستخدامها لزراعة محصول بنجر السكر بمعدل 1 فدان/ساعة، بسرعة 2-3 كم/س، بتكلفة 60 جنيه لزراعة الفدان، وحصاد محصول بنجر السكر بواقع خط فى الجرة الواحدة، حيث يتم حصاد الفدان فى 2-3 ساعة بتكلفة -200-300 جنيه/الفدان، فى مدى السرعات 1-2.5 كم/س للحصاد، وينصح تعمق أسلحة الخلخلة لعمق 30 لتفادى خدش الجذور، ونسبة سرعة سير الشد إلى تقدم الآلة 1.5 وزاوية أسلحة الخلخلة 30 درجة على الأفقى، وضبط مستوى سير الشد وسكاكين التطويش بعجلتى الآلة (ضبط العمق).

قام بتحكيم البحث

أ.د / مصطفى محمد الدسوقي ابو حجاجه  
أ.د / ايمن حلمي  
كلية الزراعة – جامعة المنصورة  
كلية الزراعة – جامعة المنوفية