

ENHANCEMENT OF PHOTOVOLTAIC SYSTEM PERFORMANCE BASED ON DIFFERENT ARRAY TOPOLOGIES UNDER PARTIAL SHADING CONDITIONS

Abdelrahman M. Mohamed^{*1}, Abou-Hashima M. El-Sayed¹, Yehia S. Mohamed¹
and Husam A. Ramadan¹

¹ Electrical Engineering Department, Faculty of Engineering, Minia University, Egypt
^{*} corresponding author E-mail: abdo_2024@protonmail.com

ABSTRACT

Partial shading conditions decreases the output power from photovoltaic systems and causes multiple maximum power points on output characteristics because of the mismatching power losses among the PV modules. The shading pattern, the shaded area and the PV array topology are the main factors which affects the mismatching power losses. The main aim of this paper is to study and enhance the performance of a PV system under different array topologies and partial shading conditions and reach to the most convenient topology. PV array topologies including series, parallel, series-parallel and total-cross-tied are studied. Row, column, narrow, wide, middle and random partial shading patterns are considered at the different PV array topologies. The performance is measured according to the maximum output power, mismatching power losses, fill factor, efficiency, open circuit voltage and short circuit current. The parameters and data specification of Suntech Power STD250-20/Wd PV module are used for the simulation based on MATLAB/Simulink software.

Keywords: Partial shading, Mismatching power losses, PV array topologies, Series, Parallel, Series-parallel, Total-cross-tied and MATLAB simulink software package.

1. INTRODUCTION

Among all renewable energy sources, PV has attracted more attention due to the price reduction of PV modules, financial governmentsupport, standardized interconnection to the electric utility grid, innovative business models in residential, commercial and utility power systems and public enthusiasm for an environmentally clean energy source [1], [2]. Solar radiation provides a large amount of energy to the earth. The total amount of energy from sun, which reaches the earth's surface, equals approximately 10,000 times the annual energy consumption for all the world. On average, 1,700 kWh per square meter every year [3].

i) Shading effect

But there are many challenges which face this promising energy. One of the main influential factors is the shading impact of atmospheric elements such as passing clouds and shadows from surrounding structures as buildings and trees which results in a non-uniform solar radiation across PV modules. Shading is classified into two main types: (a) full shading and (b) partial shading. Addressing the performance of a PV system under partial shading is more related to the improvement of system performance because partial shading happens much more often than full shading. In some old studies it is assumed that the decrease in

the output power is proportional to the shaded area and reduction in solar irradiance and it introduced the concept of shading factor. This concept can be applied only for a single cell but at the module or array level, the decrease in power is not linear with the shaded area [3]. In the fact, the three main PV module characteristics of power, voltage, and current will be affected [4]. The I-V and P-V characteristics of the solar panels become more complex with existing multiple maximum power points under the non-uniform irradiance conditions [5]. Shading effect depends on multiple factors as module type, placement gravity of shade, string configuration, bypass diode and fill factor. Power loss happens from the shade due to the current mismatch within a PV string and voltage mismatch between parallel strings [6]. A shaded module of a non-uniform illuminated PV system can lead to a negative voltage. If there is no protection, cell breakdowns can happen during non-uniform illumination [7] making a hot-spot in the module.

ii) Attempts to mitigate the shading effect

Many studies have been carried out on the effect of shading and the reduction of PV system performance in order to mitigate it [8]. One method is to implement an extra pn-junction as a bypass diode. Bypassing the shaded cells through bypass diodes proves to be a strong method to save the system from damages due to hot-spot formation and more importantly from power reduction. Integrating bypass diodes into the PV system to solve the partial shading problems may result in multiple peaks of output power [9]. In these cases, the maximum power point tracking systems face a hard task to detect the global maximum power [10], [11]. The power against voltage or against current curves have one global peak in addition to multiple local peaks and it is required to track the global one. The existence of multiple peaks decreases the efficiency of usual maximum power point tracking algorithms. To overcome the problem of multiple peaks, special algorithms are used as

genetic algorithm, cuckoo search, particle swarm optimization, ant colony optimization and teaching-learning-based optimization [12]. In another work, the usual module configuration is changed and the cells are arranged in different ways to minimize the effect of partial shading [13]. Some works have been made to study the temperature effect and variation of insulation with varying shading patterns and the role of array configuration of the PV characteristics [14]. A comparison at a large scale of series and series-parallel connected PV array topologies under partial shading conditions is made and the work is based on MATLAB/Simulink software package. The results showed that the magnitude of global maximum power point is dependent on the shading pattern and the PV array topology [15]. Another technique to extract the maximum power under partial shading conditions is to locate the PV modules physically as Su Do Ku puzzle pattern and make them connected using total-cross-tied topology. The disadvantage of this technique is ineffectual distribution of shade and the increase in wiring length and cost [16].

iii) Research objective

The main aim of this paper is to study and enhance the performance of a PV system under various array topologies and different partial shading conditions and reach to the most convenient topology.

2. MATHEMATICAL MODELING OF PV MODULE

The most commonly used model to describe the output behavior of PV cell is the single diode model. It is highly accurate and simple in predicting the PV characteristics. The module consists of several units of cells and the cell is the unit responsible for converting solar energy into electrical energy. The amount of output energy produced depends on the intensity of the solar radiation as well as the temperature. [17] In this model, the series and shunt resistance of a PV module are estimated by

using the approach proposed in [18]. Mathematical representation of a cell to describe the I-V characteristics is given from [3]:

$$I_{t,cell} = I_{PV,cell} - I_r \left[\exp\left(\frac{V_{t,cell} + R_s I_{t,cell}}{V_T,cell} a\right) - 1 \right] - \frac{V_{t,cell} + R_s I_{t,cell}}{R_{sh}} \quad \dots(1)$$

where $I_{PV, cell}$, I_r and $I_{t, cell}$ are photo current generated due to incident solar irradiance, diode reverse leakage current and terminal current of the PV cell.

$V_{t, cell}$ and $V_{T, cell} = k \times T/q$ are the terminal and thermal voltage of the PV cell; k is Boltzmann's constant and equals $(1.3806503 \times 10^{-23} \text{ J/K})$; T is the cell operating temperature (K); q is charge of the electron and equals $(1.60217646 \times 10^{-19} \text{ C})$; R_s and R_{sh} are the series and shunt resistances of the PV cell (Ω) and 'a' is the diode emission coefficient or ideality factor and the ideal value of it is 1.

Mathematical representation of a module to describe the I-V characteristics is given from:

$$I = I_{PV} - I_r \left[\exp\left(\frac{V + R_s I}{V_T a}\right) - 1 \right] - \frac{V + R_s I}{R_{SH}} \\ = I_{PV} - I_r \left[\exp\left(\frac{q(V + R_s I)}{n_s k T a}\right) - 1 \right] - \frac{V + R_s I}{R_{SH}} \quad \dots(2)$$

with n_s is the number of cells connected in series. PV module Suntech Power STD250-20/Wd are used for modeling and simulation and its parameters are given in the appendix.

3. DESCRIPTION OF DIFFERENT PARTIAL SHADING PATTERNS

The selected system consists of six modules which are fixed as 2x3 matrix. In this part the selected partial shading patterns are described. Six partial shading patterns are applied to the PV array at the different topologies as shown in figure 1 which represents different irradiation levels and different shading shapes and they are respectively:

- 1- Row partial shading.
- 2- Column partial shading.
- 3- Narrow partial shading.
- 4- Wide partial shading.
- 5- Middle partial shading
- 6- Random partial shading

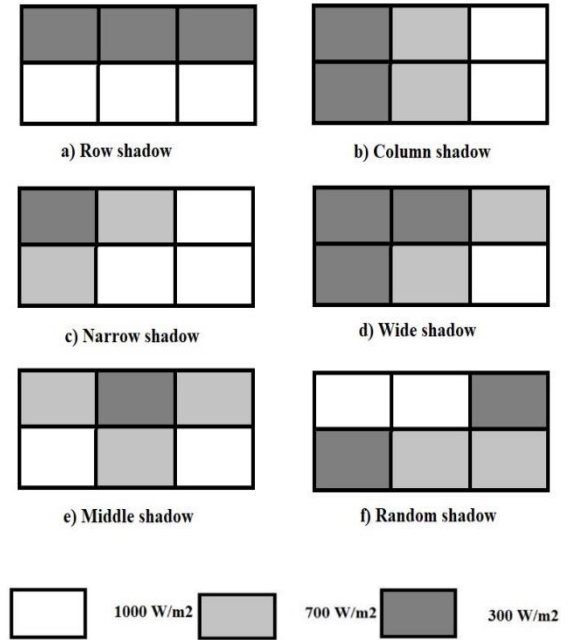

Fig.1: Six partial shading patterns which are applied to the PV system at different topologies.

In each shading pattern the solar irradiance levels are categorized into three levels of 300 W/m^2 , 700 W/m^2 and 1000 W/m^2 . The 1000 W/m^2 represents the non-shaded state. Row and column shading pattern introduces a regular shading shape. The solar irradiance of row shadow pattern consists of three modules exposed to 300 W/m^2 and the other modules are without shading. Column shadow pattern consists of two modules with 300 W/m^2 and another two modules with 700 W/m^2 . Narrow and wide shading pattern concern on the shaded area. Narrow shading pattern represents a terminal shading in which there is an one module exposed to solar radiation of 300 W/m^2 and two adjacent modules with 700 W/m^2 . Wide shading pattern introduces a large shaded area with three modules exposed to solar radiation of 300 W/m^2 and two modules having 700 W/m^2 . Middle and random shading patterns represent

the irregular shading shape. In the middle shading pattern there are one central module with 300 W/m^2 and three adjacent modules with 700 W/m^2 . The last pattern is called random shading pattern where there are two modules with 300 W/m^2 and another two modules with 700 W/m^2 without regular shape. The PV array topologies output characteristics for each shading pattern are illustrated in the next part.

4. SIMULATION OF PV ARRAY TOPOLOGIES UNDER DIFFERENT TYPES OF SHADING

This section describes the simulation of the different PV system configurations as following:

- 1- Series PV array topology (1 x 6).
- 2- Parallel PV array topology (6 x 1).
- 3- Series-parallel PV array topology (2 x 3).
- 4- Series-parallel PV array topology (3 x 2).
- 5- Total-cross-tied PV array topology (2 x 3).
- 6- Total-cross-tied PV array topology (3 x 2).

The above PV array topologies are simulated to determine the best topology under the partial shading pattern. Every module consists of sixty PV cells which are connected in series and protected by a bypass diode. Also every string is connected in series with a blocking diode to protect it. All the PV modules operate at equal and constant temperature of $25 \text{ }^\circ\text{C}$ and are exposed to various shading patterns. The description of the topologies is shown at figure 2.

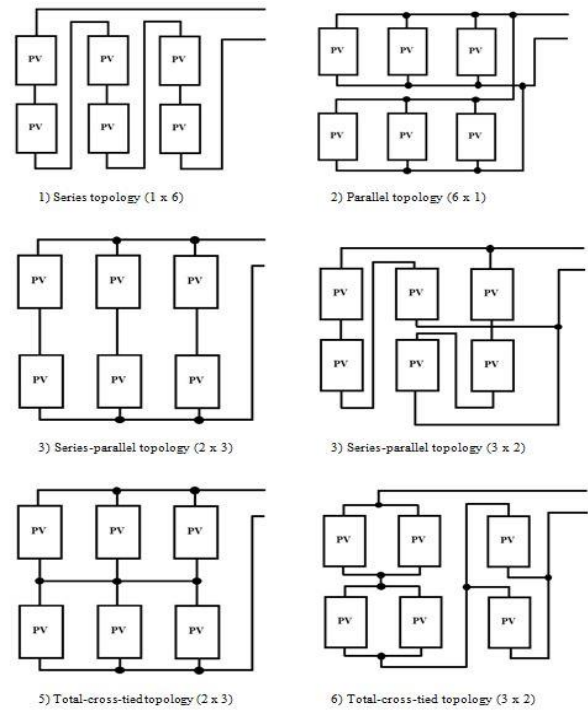

Fig.2: Six topologies which are implemented to the PV system.

4.1 Series PV array topology (1 x 6)

The MATLAB/Simulink model of series PV array topology is shown in figure 3. In this topology all the PV modules are connected in series. In series connection, the PV array current equals the module current where the array voltage equals to the sum of the individual PV modules voltages [8]. Modules which are shaded operate in reverse bias and generate a current which equals to non-shaded PV modules. So that the shaded modules, instead of delivering power they dissipate the power in the heat form making hot spots which leads to damage the PV modules. And to protect the PV modules from hot spot effects, bypass diode is connected across each module. Bypass diodes share portion of the short circuit current of the shaded modules but multiple I-V and P-V characteristics appear in a single I-V and P-V characteristics. The simulated output characteristics of series PV array topology 1x6 under various shading patterns are shown in figure 4.

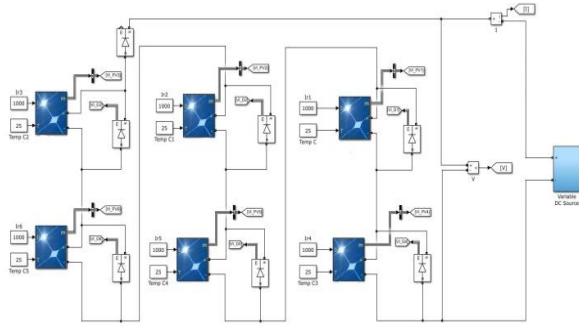

Fig.3: Series topology (1 x 6).

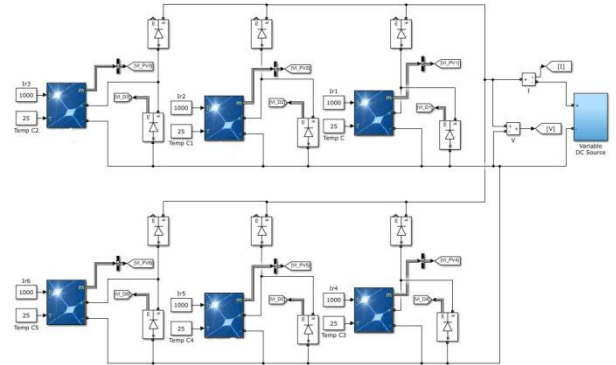

Fig.5: Parallel topology (6x1).

4.2- Parallel PV array topology (6 x 1)

In parallel connection, the PV array voltage equals to the module voltage where the array current equals to the sum of the individual PV modules currents [8]. The MATLAB/Simulink model of parallel PV array topology is shown in figure 5. Under partial shading conditions, parallel PV array topology produces more power than series PV array topology.

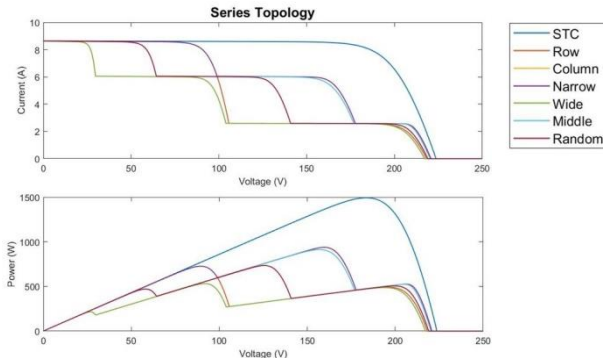

Fig.4: Series topology (I-V) and (P-V) curves under the six different partial shading patterns.

This is due to the high currents and low voltages which do not vary significantly due to the shading. However, due to higher currents, the voltage drops and power losses are higher. One of the most advantages of this topology is that it has a single maximum power point under the different partial shading patterns. The current from each PV module flows without any limit with respect to the radiation level. So that, parallel topology operates more effectively under rapidly varying solar radiation levels [1].

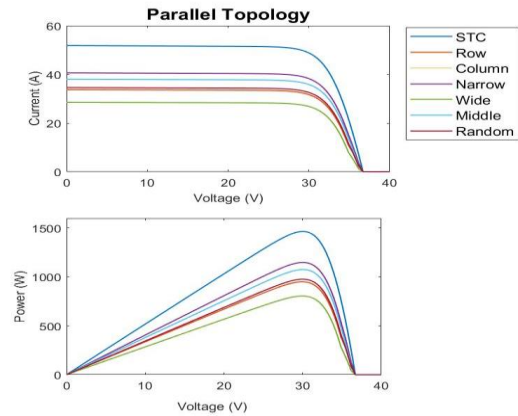

Fig.6: Parallel topology (I-V) and (P-V) curves under the six different partial shading patterns.

But due to the high current and low voltage levels, this topology is not convenient for many PV system applications. There is a blocking diode in series with every string to prevent back flow current from batteries and prevent the output current from entering to the shaded string. The simulated results (I-V and P-V characteristics) of parallel PV array topology under various partial shading patterns are shown in figure 6.

4.3 Series-parallel PV array topology

In this topology, all the PV modules are connected in series at first to form strings to provide a desired output voltage. Then these strings are connected in parallel to provide the desired output current. This topology is quite common as it is easy to build, economical, no much connections and provides reasonable voltage and current levels. It solves many problems of both series topology and parallel topology. In series-parallel PV array topology 2x3, PV

modules are divided into three strings and each string consists of two series connected modules. Where, in series-parallel PV array topology 3x2, PV modules are divided into only two strings and each string consists of three series connected modules. The MATLAB/Simulink model of 2x3 and 3x2 series-parallel PV array topology are shown in figures 7 and 9 respectively.

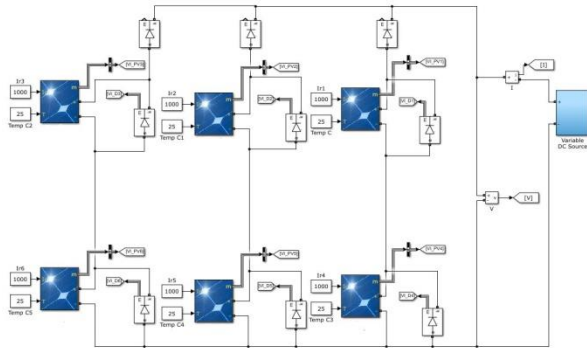

Fig.7: Series-parallel topology (2x3)

Also here, a blocking diode is inserted in series with every string to prevent reverse flow current from batteries and prevent the output current of non-shading strings from entering the shaded string and damaging it. The simulated results of output characteristics of series-parallel PV array topology 2x3 and 3x2 under the different partial shading patterns are shown in figures 8 and 10.

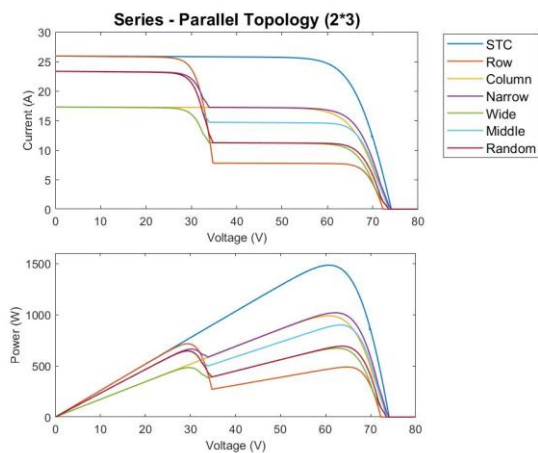

Fig.8: (I-V) and (P-V) curves of series-parallel (2x3) topology under the six different partial shading patterns.

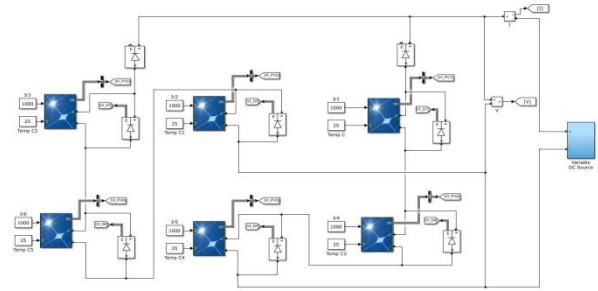

Fig.9: Series-parallel topology (3x2)

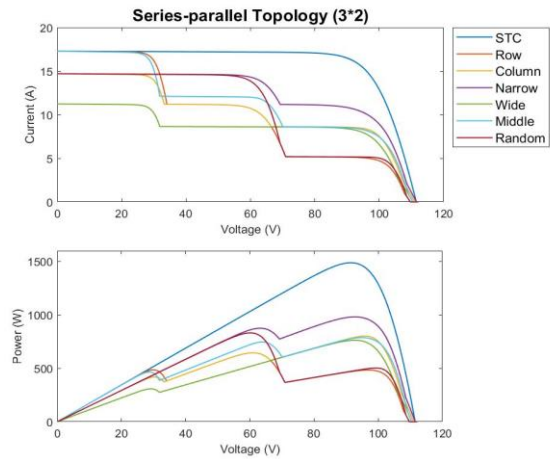

Fig.10: (I-V) and (P-V) curves of series-parallel (3x2) topology under the six different partial shading patterns.

4.4. Total-cross-tied PV array topology

Total-cross-tied PV array topology is the same as series-parallel topology but with connecting all the cross points. It solves many problems of the series, parallel and series-parallel topology. It generates a convenient open circuit voltage value and is less affected with partial shading. Not only that but it usually provides a higher maximum power when comparing to the series-parallel with the same number of strings and modules per string. However, this topology has some disadvantages as the additional wiring connections and so that more cost and more power losses in the wiring. The MATLAB/Simulink model of total-cross-tied 2x3 and 3x2 PV array topology are shown in figures 11 and 12 respectively and the simulated output results of them under the various partial shading patterns are shown in figures 13 and 14 respectively.

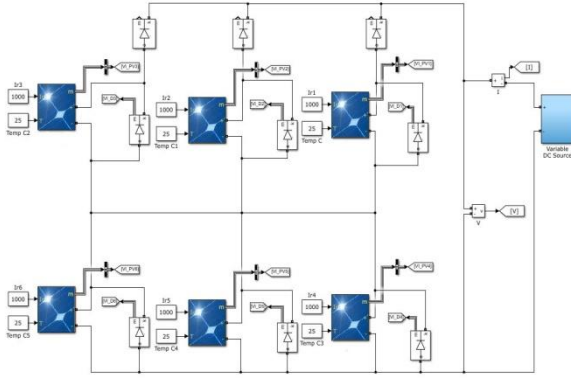

Fig.11: Total-cross-tied topology (2x3).

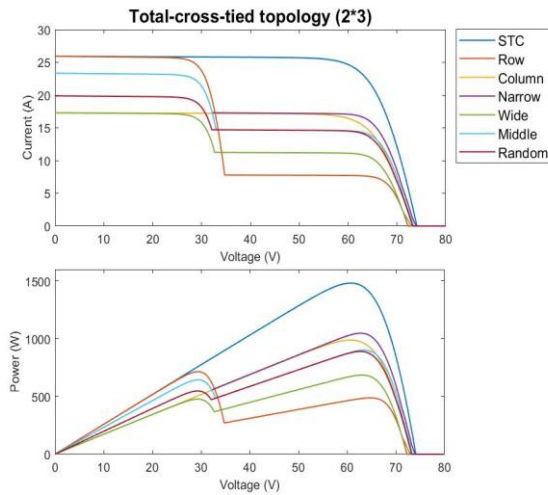

Fig.12: (I-V) and (P-V) curves of Total-cross-tied (2x3) topology under the six different partial shading patterns.

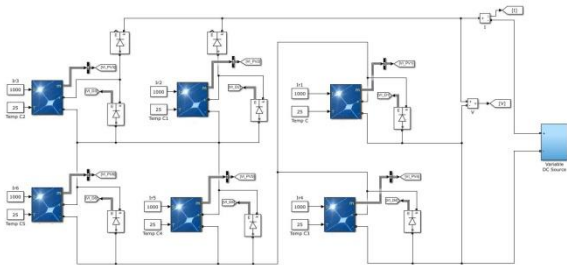

Fig.13: Total-cross-tied topology (3 x 2).

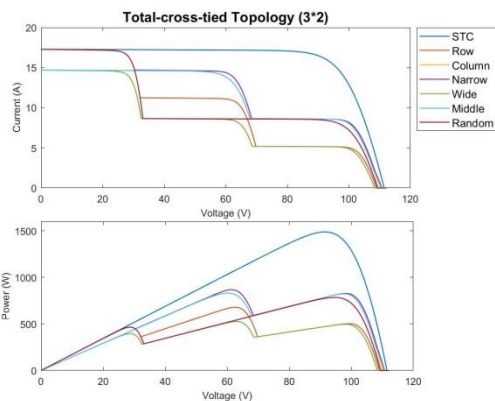

Fig.14: (I-V) and (P-V) curves of Total-cross-tied (3 x 2) topology under the six different partial shading patterns.

5-PERFORMANCE ESTIMATION OF PV SYSTEM UNDER PARTIAL SHADING

This part mentions the comparison of performance assessment of series, parallel, series-parallel 2x3, series-parallel 3x2, total-cross-tied 2x3 and total-cross-tied 3x2 PV array topologies to give the ability to choose the best topology that gives the highest performance. The performance assessment of topologies is determined with respect to three factors:

1. Mismatching power losses ΔPL %.
2. Fill factor FF %.
3. Efficiency η %.

The mismatching power loss, ΔPL % is given from the equation:[1]

$$Power\ loss, \Delta PL \% = \frac{P_{mpp} - P_{psc}}{P_{mpp}} \times 100$$

.....(3)

Where, P_{mpp} is the maximum power generated without shading (1000 W/m²) and P_{psc} the maximum power generated under partial shading patterns for the same topology. As the ΔPL value is closer to zero, the performance of the PV system is higher.

The fill factor, FF % is given from the equation:

$$Fill\ factor, FF \% = \frac{V_{mpp} \times I_{mpp}}{V_{oc} \times I_{sc}} \times 100$$

.....(4)

Where, V_{MPP} is the voltage at maximum power generated, I_{MPP} is the current at maximum power generated, V_{OC} is the open circuit voltage and I_{SC} is the short circuit current. As the FF value is closer to unity (100%), the performance of the PV system is higher.

The ratio of maximum power output to the input radiation power is called the efficiency η % of a PV system and it is calculated by the equation:

$$Efficiency, \eta \% = \frac{V_{mpp} \times I_{mpp}}{I \times A} \times 100$$

.....(5)

Where, I is the solar radiation per square meter and A is the area of the PV modules which receive the solar radiation and it can be obtained from the PV dimensions on the data sheet. As the η value is closer to unity (100%), the performance of the PV system is higher.

5.1 Uniform radiation condition without shading at standard test condition (STC)

At this condition, all the PV modules in the different topologies are subjected to a uniform radiation level of 1000 W/m^2 . The simulation results of the output characteristics of series, parallel, series-parallel 2x3 and 3x2 and total-cross-tied 2x3 and 3x2 PV array topologies are taken. Every PV array topology generates the maximum power at this condition. And there is a small difference between them due to the different number of the blocking diodes which used in each topology. Also, all of the topologies produce a single MPP on the (I-V) and (P-V) characteristics which is referred to global maximum power point. The open circuit voltages, short circuit currents and voltage, current and power at maximum power point of the PV array topologies are given in Table 1.

Under this condition, the different PV array topologies generate open circuit voltages equal to the sum of voltages of the individual series modules. Also it generates a current equal to the sum of current of the individual parallel strings. The mismatching power losses of all these topologies are equal to zero as there is no shading and the function of bypass diodes is ignored because all of the topologies operate under reverse bias condition only. The fill factor of all these topologies is almost equal to 77%. The efficiency of all these topologies is almost equal to 15.2%. Taking into account that the module efficiency is 15.4% from data sheet and the little difference of 0.2% is due to the power dissipates in the blocking diodes. Here, it is observed that series topology is the highest one and then series-parallel 3x2

and total-cross-tied 3x2 in the second level with a small difference of 5 W. The lowest one is the parallel topology because of using a six blocking diodes.

5.2 Row partial shading pattern

At this condition, the upper or lower half of the PV modules are subjected to 300 W/m^2 and the other three modules are subjected to a uniform radiation level of 1000 W/m^2 . The open-circuit voltages, short-circuit currents, maximum power, current and voltage at maximum power point, mismatching power losses, fill factor and efficiency of the different topologies at row shading pattern are listed in Table 2.

It is observed that the maximum power and performance are happened at the parallel topology. The second highest performance is at the series topology and not far from it there are the series-parallel 2x3 and total-cross-tied 2x3. And the least performance topology is the series-parallel 3x2 as it has the highest mismatching power losses value. All the efficiencies values are about 11% except the parallel topology which has the least effect of the row partial shading and it has an efficiency approaches to 15%. Also, it is observed that the series-parallel 2x3 and total-cross-tied 2x3 topologies have the same performance although using more connections in the total-cross-tied topology.

5.3 Column partial shading pattern

At this partial shading pattern, all the PV modules in the left column (two left modules) are subjected to 300 W/m^2 , the middle column (two middle modules) are subjected to 700 W/m^2 and the other two modules are subjected to a uniform radiation level of 1000 W/m^2 . The open-circuit voltages, short-circuit currents, maximum power, current and voltage at maximum power point, mismatching power losses, fill factor and efficiency of the different topologies at row shading pattern are listed in Table 3. The simulation results of the output characteristics of series,

parallel, series-parallel 2x3 and 3x2 and total-cross-tied 2x3 and 3x2 PV array topologies are taken. Here, it is observed that the maximum power and performance are happened at both series-parallel 2x3 and total-cross-tied 2x3 topologies. They have the same performance although using more connections in the total-cross-tied topology. And the series-parallel 3x2 topology is very near to them with a small difference of 11.5W (0.77%). The least performance topology is the series topology with the highest mismatching power losses and the lowest fill factor and efficiency.

5.4 Narrow partial shading pattern

Here, only one module is subjected to 300 W/m², two other nearby modules are subjected to 700 W/m² and the other three modules are subjected to a uniform radiation level of 1000 W/m². The open-circuit voltages, short-circuit currents, maximum power, current and voltage at maximum power point, mismatching power losses, fill factor and efficiency of the different topologies at row shading pattern are listed in Table 4. Here, it is observed that the maximum power and performance are happened at the parallel topology. The second highest performance is the total-cross-tied 2x3 topology with a difference of 100 W (6.7%). And the least performance topology is the total-cross-tied 3x2 as it has the highest mismatching power losses and lowest form factor and efficiency. Total-cross-tied 2x3 is more than series-parallel 2x3 with a 30 W (2%). Also Total-cross-tied 3x2 is more than series-parallel 3x2 with a 113.5 W (7.57%).

5.5 Wide partial shading pattern

In wide partial shading pattern, three modules are subjected to 300 W/m², two other nearby modules are subjected to 700 W/m² and only one module is subjected to a uniform radiation level of 1000 W/m². The open-circuit voltages, short-circuit currents, maximum power, current and voltage at maximum power point, mismatching power losses, fill factor and efficiency of the different topologies at row shading pattern

are listed in Table 5. From the table, it is observed that the maximum power and performance are happened at the parallel topology. The second highest performance is the series-parallel 3x2 topology with a difference of 42.4 W. And the least performance topology is the total-cross-tied 3x2 as it has the highest mismatching power losses and lowest fill factor and efficiency. When comparing series-parallel with total-cross-tied it is observed that series-parallel has higher output power with a 236.4 W (15.76%) for 2x3 topology where total-cross-tied is higher with 13.8 W (0.92%) for 3x2 topology.

5.6 Middle partial shading pattern

At this pattern, a one middle PV module is subjected to 300 W/m², three around modules are subjected to 700 W/m² and the rest terminal two modules are subjected to a uniform radiation level of 1000 W/m². The open-circuit voltages, short-circuit currents, maximum power, current and voltage at maximum power point, mismatching power losses, fill factor and efficiency of the different topologies at row shading pattern are listed in Table 6. From the results, it is observed that the maximum power and performance are happened at the parallel topology. The second highest performance is the series topology with a big difference of 162.1 W. And the least performance topology is the series-parallel 3x2 as it has the highest mismatching power losses and lowest fill factor and efficiency. Total-cross-tied 2x3 provides a performance near to the series topology with a small decrease of 11.2 W (0.75%) so it also can be a good choice under this partial shading pattern.

5.7 Random partial shading pattern

At this pattern, two terminal PV modules are subjected to 300 W/m², another two modules are subjected to 700 W/m² and the rest two modules are subjected to a uniform radiation level of 1000 W/m². The simulation results of the output characteristics of series, parallel, series-parallel 2x3 and 3x2 and total-cross-tied 2x3 and 3x2 PV array topologies are taken as in

all previous partial shading patterns. The open-circuit voltages, short-circuit currents, maximum power, current and voltage at maximum power point, mismatching power losses, fill factor and efficiency of the different topologies at row shading pattern are listed in Table 7. From the results, it is observed that the maximum power and performance are happened at the parallel topology. The second highest performance is the total-cross-tied 2x3 topology with a difference of 86.3 W (5.75%). And the least performance topology is the series-parallel 2x3 as it has the highest mismatching power losses and lowest fill factor and efficiency.

6. CONCLUSION

This research article has investigated the performance of different PV array topologies. Series, parallel, series-parallel 2x3 and 3x2 and total-cross-tied 2x3 and 3x2 PV array topologies are studied at a six modules PV system. The effect of various partial shading patterns such as; row, column, narrow, wide, middle and random partial shading patterns are determined on

the different topologies performance. The output characteristics (I-V and P-V curves) are discussed and analyzed. A comparison between the PV array topologies is determined through measuring the short-circuit current, open-circuit voltage, maximum power, voltage and current at the maximum power, fill factor, power losses and efficiency. From the present analysis one can draw that: If the partial shading pattern which occurs a lot can be predicted, the selection of the best topology is available easily from calculating as the different tables obtained in this research. But if the partial shading which occurs a lot cannot be predicted or the system exposes to unpredictable different patterns, the total-cross-tied 2x3 is highly recommended as it gives a reasonable voltage and current levels and its performance in average is good at standard test conditions and under partial shading patterns. It is noted that the more series connections, the greater energy loss so the total-cross-tied 2x3 is preferred.

* Bold lines in the tables shows the two highest performance topology under the partial shading condition.

Table 1: Simulation results under uniform radiation of (1000 W/m²) without shading.

Topology	Voc (V)	Isc (A)	Pmax (W)	Vmpp (V)	Impp (A)	ΔPI%	FF%	η%
Series	223.7	8.65	1493	183.6	8.13	—	77.16	15.29
Parallel	36.69	51.91	1465	30.03	48.77	—	76.92	15.01
Series-parallel 2x3	74.09	25.96	1482	60.74	24.4	—	77.05	15.18
Series-parallel 3x2	111.5	17.3	1488	91.44	16.27	—	77.14	15.24
Total-cross-tied 2x3	74.13	25.96	1482	60.74	24.4	—	77.01	15.18
Total-cross-tied 3x2	111.5	17.3	1488	91.44	16.27	—	77.14	15.24

Table 2: Simulation results under row partial shading pattern.

Topology	Voc (V)	Isc (A)	Pmax (W)	Vmpp (V)	Impp (A)	$\Delta PI\%$	FF%	$\eta\%$
Series	218.2	8.65	726.6	89.42	8.13	51.33	38.50	11.45
Parallel	36.69	33.74	949.8	31.75	29.92	35.17	76.73	14.97
Series-parallel 2x3	72.26	25.96	715.1	29.36	24.36	51.75	38.12	11.27
Series-parallel 3x2	109.7	17.3	644.7	60.96	10.58	56.67	33.97	10.16
Total-cross-tied 2x3	72.29	25.96	715.1	29.36	24.36	51.75	38.11	11.27
Total-cross-tied 3x2	108.9	17.3	679.5	62.61	10.85	54.33	36.07	10.71

Table 3: Simulation results under column partial shading pattern.

Topology	Voc (V)	Isc (A)	Pmax (W)	Vmpp (V)	Impp (A)	$\Delta PI\%$	FF%	$\eta\%$
Series	219	8.65	734.4	125.7	5.84	50.81	38.77	11.28
Parallel	36.69	34.61	976.3	29.99	32.55	33.36	76.88	15.00
Series-parallel 2x3	74.09	17.3	987.8	60.66	16.28	33.35	77.07	15.18
Series-parallel 3x2	110.9	14.71	801.7	95.86	8.36	46.12	49.14	12.32
Total-cross-tied 2x3	73.42	17.3	987.8	60.66	16.28	33.35	77.77	15.18
Total-cross-tied 3x2	109.9	17.3	784.5	94.55	8.3	47.28	41.26	12.05

Table 4: Simulation results under narrow partial shading pattern.

Topology	Voc (V)	Isc (A)	Pmax (W)	Vmpp (V)	Impp (A)	$\Delta PI\%$	FF%	$\eta\%$
Series	220.8	8.65	938.3	159.7	5.88	37.15	49.13	12.27
Parallel	36.69	40.67	1148	30.03	38.22	21.64	76.93	15.01
Series-parallel 2x3	74.09	23.36	1018	62.12	16.38	31.31	58.82	13.31
Series-parallel 3x2	111.5	14.71	981.2	92.68	10.59	34.06	59.82	12.83
Total-cross-tied 2x3	73.93	23.36	1048	62.76	16.69	29.28	60.68	13.70
Total-cross-tied 3x2	110.7	17.3	867.7	61.34	14.15	41.69	45.31	11.35

Table 5: Simulation results under wide partial shading pattern.

Topology	Voc (V)	Isc (A)	Pmax (W)	Vmpp (V)	Impp (A)	$\Delta PI\%$	FF%	$\eta\%$
Series	217.2	8.65	531.7	91.78	5.79	64.39	28.30	9.90
Parallel	36.69	28.55	804.7	29.96	26.86	45.07	76.82	14.99
Series-parallel 2x3	73.53	17.3	671.4	62.57	10.73	54.70	52.78	12.50
Series-parallel 3x2	110.4	11.25	762.3	92.68	8.23	48.77	61.38	14.20
Total-cross-tied 2x3	73	17.3	685.2	63.06	10.87	53.77	54.26	12.76
Total-cross-tied 3x2	108.4	14.71	525.9	62.91	8.36	64.66	32.98	9.79

Table 6: Simulation results under middle partial shading pattern.

Topology	Voc (V)	Isc (A)	Pmax (W)	Vmpp (V)	Impp (A)	$\Delta PI\%$	FF%	$\eta\%$
Series	220.2	8.65	912.9	157	5.82	38.85	47.93	12.75
Parallel	36.69	38.07	1075	30.03	35.81	26.62	76.96	15.02
Series-parallel 2x3	73.53	23.36	898.7	63.32	14.19	39.36	52.32	12.55
Series-parallel 3x2	110.4	17.3	787.1	95	8.29	47.10	41.21	10.99
Total-cross-tied 2x3	73.42	23.36	901.7	63.47	14.21	39.16	52.57	12.60
Total-cross-tied 3x2	110.5	14.71	831.4	60.14	13.82	44.13	51.15	11.61

Table 7: Simulation results under random partial shading pattern.

Topology	Voc (V)	Isc (A)	Pmax (W)	Vmpp (V)	Impp (A)	$\Delta PI\%$	FF%	$\eta\%$
Series	219	8.65	734.4	125.6	5.85	50.81	38.77	11.28
Parallel	36.69	34.61	976.3	29.99	32.55	33.36	76.88	15.00
Series-parallel 2x3	74.35	23.36	691.3	63.62	10.87	53.35	39.80	10.62
Series-parallel 3x2	109.7	14.71	831.4	60.14	13.82	44.13	51.52	12.78
Total-cross-tied 2x3	73.23	19.9	890	62.72	14.19	39.95	61.07	13.68
Total-cross-tied 3x2	109.4	17.3	784.5	94.47	8.3	47.28	41.45	12.05

REFERENCES

- [1] S. R. Pendem and S. Mikkili, "Modelling and performance assessment of PV array topologies under partial shading conditions to mitigate the mismatching power losses," *Solar Energy*, vol. 160, pp. 303-321, 2018.
- [2] D. Sera and Y. Baghzouz, "On the impact of partial shading on PV output power," in *WSEAS/IASME International Conference on Renewable Energy Sources*, 2008, pp. 229-234.
- [3] M. Patel, "Wind and Solar Power Systems," Taylor & Francis Group, 2006.
- [4] B. A. Alsayid, S. Y. Alsadi, S. J. Ja'far, and M. H. Dradi, "Partial shading of PV system simulation with experimental results," *Smart Grid and Renewable Energy*, vol. 4, p. 429, 2013.
- [5] S. R. Chowdhury and H. Saha, "Maximum power point tracking of partially shaded solar photovoltaic arrays," *Solar energy materials and solar cells*, vol. 94, pp. 1441-1447, 2010.
- [6] R. Bruendlinger, B. Bletterie, M. Milde, and H. Oldenkamp, "Maximum power point tracking performance under partially shaded PV array conditions," *Proc. 21st EUPVSEC*, pp. 2157-2160, 2006.
- [7] L. Fialho, R. Melicio, V. Mendes, J. Figueiredo, and M. Collares-Pereira, "Effect of shading on series solar modules: simulation and experimental results," *Procedia Technology*, vol. 17, pp. 295-302, 2014.
- [8] S. Moballegh and J. Jiang, "Partial shading modeling of photovoltaic system with experimental validations," in *2011 IEEE Power and Energy Society General Meeting*, 2011, pp. 1-9.
- [9] S. Silvestre, A. Boronat, and A. Chouder, "Study of bypass diodes configuration on PV modules," *Applied Energy*, vol. 86, pp. 1632-1640, 2009.
- [10] A. Kajihara and A. Harakawa, "Model of photovoltaic cell circuits under partial shading," in *2005 IEEE International Conference on Industrial Technology*, 2005, pp. 866-870.
- [11] H. Rezk, A. Fathy, and A. Y. Abdelaziz, "A comparison of different global MPPT techniques based on meta-heuristic algorithms for photovoltaic system subjected to partial shading conditions," *Renewable and Sustainable Energy Reviews*, vol. 74, pp. 377-386, 2017.
- [12] F. Lu, S. Guo, T. M. Walsh, and A. G. Aberle, "Improved PV module performance under partial shading conditions," *Energy Procedia*, vol. 33, pp. 248-255, 2013.
- [13] C. Deline, "Partially shaded operation of a grid-tied PV system," in *2009 34th IEEE Photovoltaic Specialists Conference (PVSC)*, 2009, pp. 001268-001273.

[14] H. Patel and V. Agarwal, "MATLAB-based modeling to study the effects of partial shading on PV array characteristics," IEEE transactions on energy conversion, vol. 23, pp. 302-310, 2008.

[15] Rani, B., et al., "Enhanced power generation from PV array under partial shading conditions by shade dispersion using Su Do Ku configuration," IEEE Trans. Sustain. Energy, vol. 4, pp. 594–601, 2013.

[16] Mäki, Anssi, et al., "Operation of series-connected silicon-based photovoltaic modules under partial shading conditions". Prog. Photovolt: Res. Appl. 20, pp. 298–309, 2012.

[17] Ka Lok Man, T. O. Ting, Nan Zhang, Sheng-Wei Guan and Prudence W. H. Wong "Approximate Single-Diode Photovoltaic Model for Efficient I-V Characteristics Estimation," The Scientific World Journal, Vol. 2013, Article ID 230471, 7 pages.

[18] Carrero, C., et al., "Simple estimation of PV modules loss resistances for low error

Modeling," Renewable Energy, vol. 35, pp. 1103–1108, 2010.

APPENDIX

Parameters of Suntech Power STD250-20/Wd PV module:

Maximum power, P_{max} (at STC) = 250 W

Voltage at maximum power, V_{mpp} = 30.7 V

Current at maximum power, I_{mpp} = 8.15 A

Open circuit voltage, V_{OC} = 37.4 V

Short circuit current, I_{SC} = 8.63 A

Module efficiency η = 15.4%

Solar cell type: Polycrystalline silicon

Number of cells per module= 60

Dimensions: 1640 x 992 x 35 mm

Weight: 18.2 kg

Series resistance, R_s = 0.268 Ω

Shunt resistance, R_{sh} = 375.15 Ω

Diode ideality factor, a = 0.978 Ω

Temperature coefficient of V_{OC} , K_v = -0.34%/°C

Temperature coefficient of I_{SC} , K_i = 0.057%/°C

تحسين أداء منظومة كهروضوئية تحت تأثير التظليل الجزئي باستخدام طوبولوجيا توصيل مختلفة

الملخص:

تعمل ظروف التظليل الجزئي على تقليل القدرة الكهربائية الناتجة من الأنظمة الفوتوفولتية وتتسبب في ظهور أكثر من نقطة أعلى قدرة في منحنيات الخرج بسبب عدم تناسق فقدان الطاقة بين الوحدات الفوتوفولتية. نمط التظليل ومساحة المنطقة المظلمة وطوبولوجيا التوصيل هي العوامل الرئيسية التي تؤثر على مقدار فقدان الطاقة بسبب عدم التناسق. الهدف الرئيسي من هذا البحث هو نمذجة ومحاكاة وتحسين أداء النظام الفوتوفولتي تحت طوبولوجيا متعددة وظروف تظليل جزئية مختلفة ومن ثم الوصول إلى الطوبولوجيا الأكثر ملاءمة. تمت دراسة طوبولوجيا التوالي والتوازي والتوازي معاً وكذلك الترابط الكلي. يتم النظر في أنماط التظليل الجزئي للصف والعمود والضيق والواسع والمتوسط والعشوائي مع كل اشكال الطوبولوجيا المختلفة. يتم قياس الأداء وفقاً لأقصى طاقة خرج ، وفقدان الطاقة بسبب عدم التناسق ، ومعامل الامتلاء ، والكفاءة ، وجهد الدائرة المفتوحة ، وتيار القصر. تم استخدام وحدة الطاقة الشمسية الفوتوفولتية من نوع Suntech Power STD250-20 / Wd وتم بناء المحاكاة على برنامج الماتلاب سميولينك.