

THE UTILIZATION OF THE PICK UP MACHINE TO OVERCOME THE FIELD RESIDUES

Ismail, Z.E.*; E. H. El-Hanfy** and A.S. Elsayed*

* Agric. Eng. Fac. of Agric. Mansoura Univ.

** Inst. For Efficient Productivity, Zagazig Univ. Egypt.

ABSTRACT

The aim of the present study has been concerned with a particular problem, associated with the pickup drum of the balers. That aim was seen to be achieved through developing a new design for the pickup drum, which its idea depend on using the picker chains and claw elevator chains instead of using the usual tines in the currently balers in the minister of the agriculture. This investigation carried out to study the effect of the engineering parameters of the four rotation speeds for the double job units (pickup plus elevating straw) for the proposed design, three of chassis tilt angles, three of straw feed rates and three levels of straw holder heights on the straw elevated efficiency and loss percentage for the proposed design. Also evaluate the machine performance by determining the machine field capacity and productivity.

The results indicated that the best value of straw elevated quantity was 7.075 kg/min, which obtained at 102 rpm rotation speed of the combined units and straw feed rate 4 kg/min. For increasing the straw holder's heights from 0 to 2 cm increases the field capacity from 0.058 fed/h to 0.086 fed/h at decreasing the chassis tilt angles from 36 to 28 degree. Also increasing the straw holder's heights from 2 to 4 cm increases the field capacity from 0.06 to 0.096 fed/h at increasing tilt angles from 28 and 36 degree.

INTRODUCTION

Field residues represent a big problem on the agriculture environment. From this residues that represent high percentage in the agriculture production is rice straw (about 35% of total residues). Yearly, there are about 0.63 million hectares (1.5 million feddans) cultivated area with rice. This results in nearly 4 million tones of rice straw (The Statistical Year Book-2005). The equipments that dealing with rice straw residues after harvesting directly are Balers and Step rod machines (ASAE-2007).

The majority of these equipments in Egypt are the Balers machines, and we have take care in this manuscript to limit the technical problems that face the pick-up and elevator units in these machines and try to solve this problems to increase the pick-up efficiency and decrease the cost of maintenance operations. Srivastava *et al.* (1995) stated that the two types of balers in popular use are rectangular balers and round balers. Baling of hay, the same machines are used for baling straw and other fibrous materials. Ismail *et al.* (2007) indicated that the type of pickup reel that is used on a mower-conditioner is also used on other machines, for example, forage harvesters and combines illustrate three different types of mechanisms used in pickup reels. There are reel teeth parallel with eccentric spider control, cam control and planetary gear control.

The general review indicated that there are three types of conveyers. In one type, an auger conveys the hay or rice straw to asset of packer fingers which sweep the straw into the bale chamber. In a second type, linear moving

picker fingers travel the full width of the pickup in conveying the straw into the bale chamber. In a third type, rotating finger wheels move the hay laterally to the packer fingers (Richey., 1961).

Kamei and Amana (1998) studied the effects of straw pickup operating speed on power requirement under a chain conveyor and a roller type. They showed that roller type offered higher packing density than the chain conveyor, but required more power, and the bale dry matter density per unit power was lower. While, Morad et al. (2002), found that the economic forward speed was 3 km/h corresponding to feed rates of 3, 2.4 and 5.7 ton/h for rice straw, wheat straw and alfalfa respectively. They mentioned that pickup baler forward speed between 2-3 km/h is recommended to optimize feed rate and minimize both baler losses and cost. They also mentioned that the plunger speed of 97 m/min is recommended to minimize number of bales.

El- Ghonimey and Rostom (2002) studied four different balers, Welger (Ap 530), Class (55), CiCoria (747) and Galligan (5190), to evaluate their performance for handling rice straw. These types are similar in driving power source (PTO), pickup theory, and pressing operation theory, while they have some substantial differences in internal transmission mechanism, rate of performance, bales quality, and total costs. They found that the pick up losses increased by increasing each of the forward speeds (2.5, 3.5 and 4.5 km/h) respectively. Also they found that the arrangement of balers according to lowest baling cost was CiCoria (747), Class (55), Welger (Ap 530), and Galligan (5190) respectively.

From above researchers the straw of rice represent the big problems, therefore the general objective of this study was to develop a unit to utilize the best pick-up with the highest elevating efficiency. The specific objectives were (1) to conduct tests in the lab using the developed unit with different pick-up forward speed to study the effect of the double job units rotation speed, Straw feed rate and straw holder's heights on the efficiency and productivity at the different chassis tilt angles. (2) To reduce the operation times and improve the machine field capacity.

MATERIALS AND METHODS

The General Description of the Proposed Design

As shown in Figs. 1 and 2 the proposed design of combined unit can be classified as the following components:-

- 1- The header unit;** It is consisted of the front knife, straw pick-up chains and straw holders.
- 2- Elevator unit;** It have a straw elevator chains (claw chains).
- 3- Transmission system;** It use to convey the power from tractor "PTO" to the elevator and to reduce and to control on the fingers rotating speed.
- 4- The complementary parties;** Three point hitching system and the frame of machine are investigated to side mount on the 65hp tractor and to supply power by PTO of tractor. The main dimensions of the investigated implement are; the total length is 176 cm, total width is 130 cm and total height is 70 cm.

Machine operation system

The straw elevator unit elevates the rice straw from soil surface by picker to the storage unit. It is consisting of the pick-up and the straw elevator chains. The picker units are connected together with elevator units in a double job units which picking up plus elevating rice straw residues in one step. There are two double units in the proposed design. The elevator chains left the straw by it is fixed claws. There are eighteen claws fixed in one chain. The claws rotate in a path over the rails in the locked chains case. The claws path lead to appear nine claws only that left the straw and the other nine claws hidden in the case and ready to appear from the front of the chains case. The claws made of special kind of polyethylene that resists wearing. The distance between every two claws is (9 cm). The claws chain has the rotation from the rear sprocket (20 teeth). The claws chain can be tightened by its front tension springs which pulls the front chains roller. The front tension springs have two jobs; first make the chain tightened continually, second to absorb the shocks in case of the heavy load of rice straw to prevent the chain from cutting. The chains case is (96 cm) length and fixed on the chassis by it is front stays.

The investigated unit was tested in farm Lab of Ag. Eng. Department. The implement efficiency was tested and evaluation by the investigated unit. The main specifications of rice straw are tabulated in table (1). For optimization of the affecting the performance of investigated unit, experiments were conducted with four levels of double job units rotation speed of 40, 58, 78, 102 rpm (table 2) with three levels of header till angles (28, 32 and 36 degree) and three levels of straw holder height (0, 2 and 4 mm). The tests were replicated three times for each treatments of pick-up unit. The data were statistically analyzed to determine the effect of the above variables on straw flow rate, machine efficiency and the unit capacity.

Straw pickup efficiency (E, %) was calculated from the following equation:

$$E = \frac{Pm}{Sm} \%$$

Where:

Pm: straw picked mass, g

Sm: mass of straw residues, g

The straw pickup losses (L, %) were calculated as follows:

$$L = \frac{Sm - Pm}{Sm} \%$$

The proposed design field capacities for rice straw pick-up elevator were calculated as follows:

$$Fc = P \times \frac{1}{C}$$

Where:

P: The proposed design productivity, ton/h

C: Constant = according the rice straw residues per feddan (3 ton/fed)

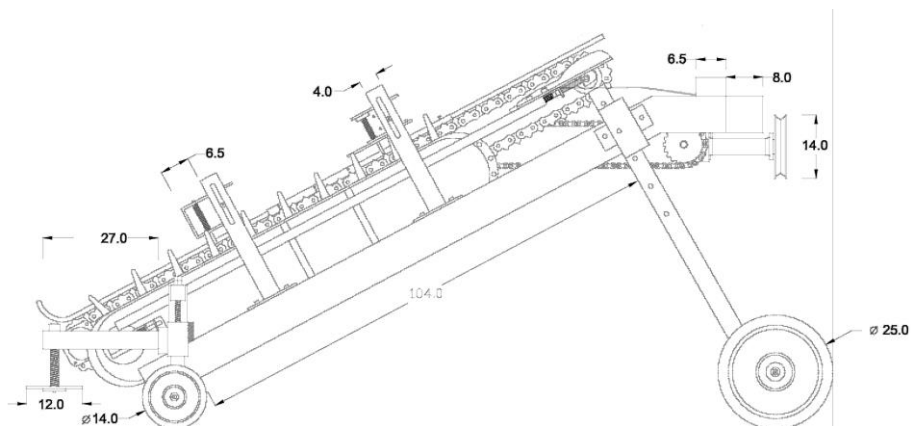

Fig. 1: The proposed pick-up elevator.



Fig. 2: the side mounted of the machine with tractors

Table (1): The average of the rice straw specification.

Function	The straw length (mm)	The straw diameter(mm)	Mass of one stalk (kg)	Moisture content %
Min.	625	2.5	0.059	15.46
Max.	820	4	0.068	
Average	722.5	3.25	0.0635	

Table (2): The revaluation number of main, coupler and media driven gears of machine

Turnery gear box rotation rpm	Turnery sheave (9cm diameter) rpm	Differentials sheave (14cm diameter) rpm	Differential gear (20teeth) rpm	Unit gear (14 teeth) rpm	straw discharge chain gear rpm
58	62	40	28	40	35
76	80	58	46	58	53
96	100	78	66	78	73
120	124	102	90	102	97

RESULTS AND DISCUSSION

The evaluation of the pick-up straw machine is carried out to investigate the effect of the engineering parameters of the elevator unit by analyzing the relative relationships between the various parameters such as the effect of the rotation speed of the elevator chains, the straw holders heights and the straw feeding rates on the straw elevated quantity and the machine productivity at different chassis tilt angles. The results could be discuss as follows:

The pick-up efficiency and losses

The relationships between the double job units rotation speed, straw feed rate and straw holder's heights on the straw pick-up efficiency and losses at the different chassis tilt angles are illustrated in Fig. (3). The results as shown in Fig.(3) indicated that the highest value of straw pick-up efficiency was 97.4 % obtained at 40 rpm of the double job unit rotation speeds and the chassis tilt angle was adjusted at 36 degree. While the highest value of straw pick-up losses was obtained at 102 rpm of the double job unit rotation speeds and the chassis tilt angle of 28 degree.

Also increasing the combined unit rotation speed decreases the straw pick-up efficiency at different chassis tilt angles. The rates of the decrement are about "50.13 %" at increasing the combined unit rotation speeds from 40 to 58 rpm, while this rate is decreased by "49.87 %" at increasing the rotation speed from 78 to 102 rpm (Fig. 3-b). The vise versa was found at straw pick-up losses. The rate of straw losses increasing about "46.03 %" at increasing the combined unit rotation speeds from 40 to 58 rpm. This rate is "53.97 %" at increasing the rotation speed from 78 to 102 rpm (Fig. 3-e). On the other side, increasing the straw holder height the pick-up efficiency is deceased and the straw losses in percentage are increased.

A simple power regression analysis applied to relate the change in straw pickup efficiency (E,%) and loses (L,%) in percentage with the change in double job units rotation speed (S), chassis tilt angle(T), straw feed rate (Fr) and straw holder height (H) for all treatment. The obtained regression equations were in the form of:

$$E = 98.51 - 0.011 S + 0.053 T - 0.73 Fr - 0.2H$$
$$L = 01.49 + 0.011 S - 0.053 T + 0.73 Fr + 0.2 H$$

The factors affecting the straw elevated quantity (Gq)

The relationships between the double job unit rotation speed on the straw elevated quantity (Gq) at different chassis tilt angles, straw feed rate and straw holder's heights are illustrated in Fig. (4). Generally, the results indicated that the highest value of straw elevated quantity (Gq) was 6.19 kg/min, obtained at 102 rpm of the double job unit rotation speed and the chassis tilt angle was adjusted at 36 degree and the regulation of straw holders height was 4cm. While the lowest value of the straw quantity was recorded at 2.47 kg/min and the rotation speed of the double job unit was 40 rpm at chassis tilt angle of 28 degree for straw feed rate of 2.0kg/mim and straw holder regulation of zero level.

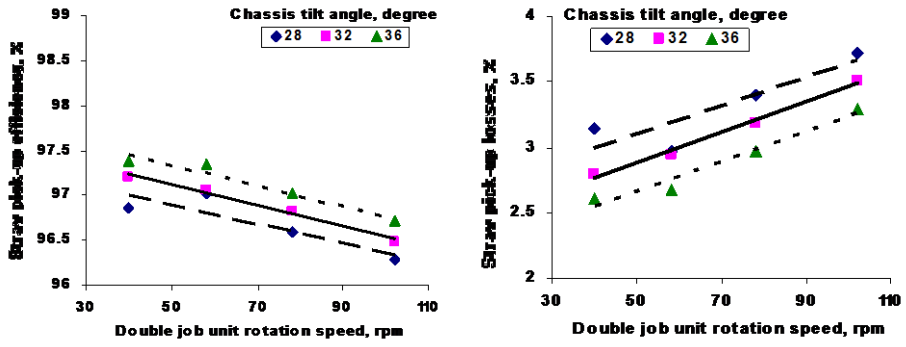

A- Double job unit rotation speed, rpm

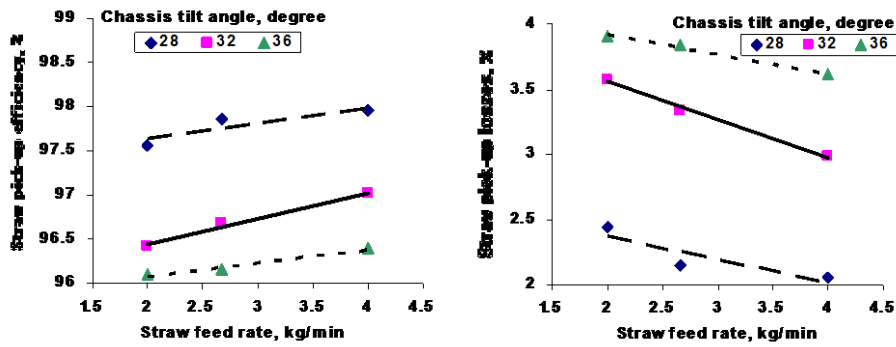

B- Straw feed rate, kg/min

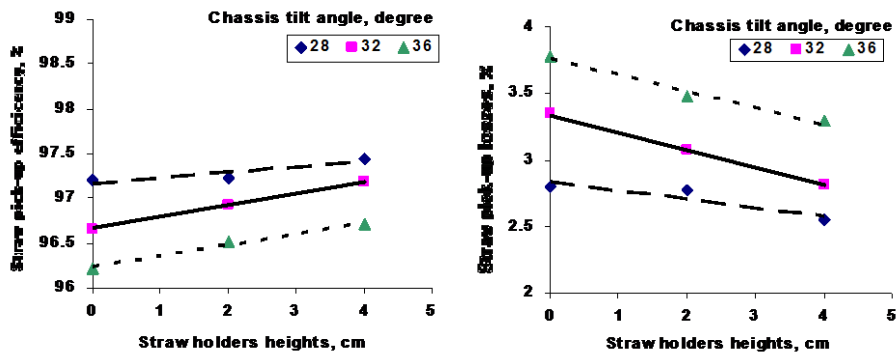

C- Straw holders heights, cm

Fig. (3): The effect of factors (A, B and C) on straw pick-up efficiency and losses.

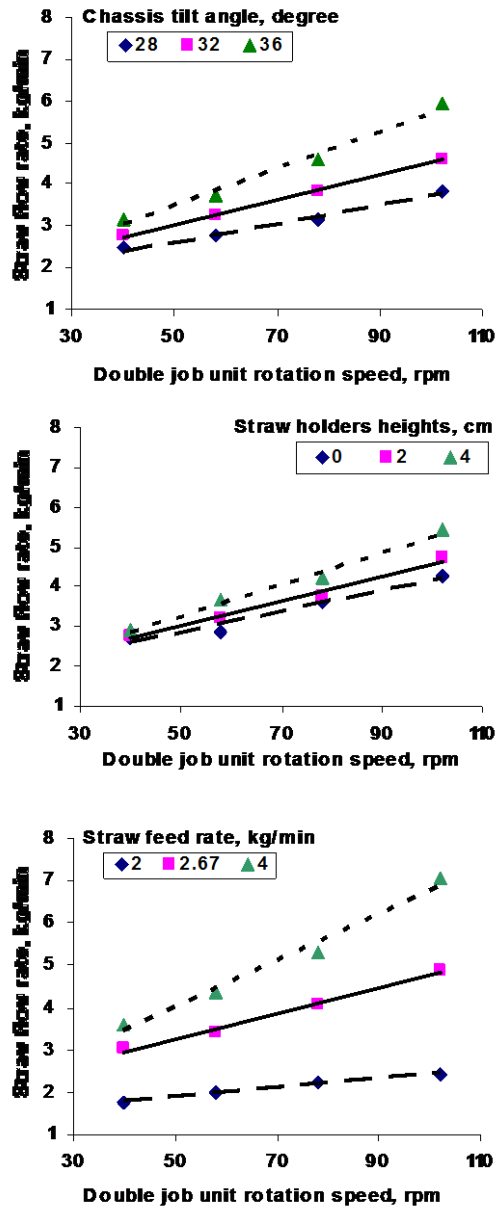

Fig. (4): Effect of the rotation speed of the double job unit on the straw flow rate.

As shown in Fig. (4), it was obvious that increasing the combined unit's rotation speed increases the straw quantity at the different chassis tilt angles. The rate of the increasing is about "41.14 %" at increasing the combined unit rotation speed from 40 to 58 rpm while, this rate is "58.86 %" at increasing the rotation speed from 78 to 102 rpm. Increasing the straw feed rate from 2

to 2.67 kg/min increases the straw quantity from 1.91 kg/min to 5 kg/min and from 1.91 to 5 kg/min at 28° and 36° of chassis tilt angles respectively also increasing the feed rate from 2.67 to 4.0 kg/min increases the straw quantity from 2.09 kg/min to 6.19 at increasing the chassis tilt angle from 28° to 36°.

The effect of straw holder height on the straw quantity (kg/h) is illustrated in Fig. (5). The straw quantity is directly proportion with the holder height. The maximum value of straw quantity was 4.805 kg/min obtained at 4 cm of straw holder's height with the chassis tilt angle of 36 degree. While the minimum value of the straw quantity was recorded at 2.88 kg/min at zero of straw holder's height with the chassis tilt angle of 28 degree. Increasing the straw holder's heights from 0 to 2 cm increases the straw elevated quantity from 2.88 kg/min to 4.07 kg/min at increasing the chassis till angle from 28 to 36°. Also, increasing the straw holder's heights from 2 to 4 cm increases the straw quantity from 3.22 kg/min to 4.8 kg/min at 28°.

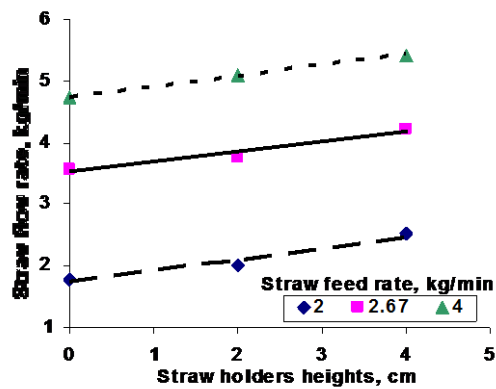

Fig. (5): straw quantity via straw holder height

The statistically analysis of SAS showed that, there is high significance effect for the treatments of the double job unit rotation speed (S, rpm), chassis tilt angle (T, degree), straw feed rate (Fr, kg/min) and straw holder height (H, cm) to the machine straw quantity (Gq, kg/min). Also the total interaction between different treatments show a significant effect with ($R^2 = 0.98$) and ($CV=8.8$).

A simple power regression analysis applied to relate the change in straw quantity (FI, kg/min) with the change in double job units rotation speed, chassis tilt angle, straw feed rate and straw holder height for all treatment. The obtained regression equation was in the form of:

$$FI = -8.17 + 0.032 S + 0.16 T + 1.41 Fr + 0.18 H$$

From a above equation, the double job unit rotation speed that utilize the maximum quantity of straw elevated (6.0kg/min) was 156.56 rpm at $T=28^\circ$, $Fr = 3.0$ kg/h, $H = 2.5$ cm. Deceasing the "S" to 120 rpm, the same value of the maximum straw elevated quantity may be found at the tilt angle of 35.12 degree for the same operation parameters.

The factors affecting the machine field capacity

As shown in Fig. (6), it was obvious that increasing the combined unit's rotation speed increases the field capacity (fed/h) at the different chassis tilt

angles, straw holder height and straw feed rate. The rate of the increasing is about "41.06 %" at increasing the combined unit's rotation speed from 40 to 58 rpm, while this rate is "58.94 %" at increasing the rotation speed from 78 to 102 rpm. In addition, the results indicated that the highest value of field capacity 0.124 fed/h was obtained at 4 kg/min of the straw feed rate and the chassis tilt angle was adjusted at 36 degree. While the lowest value of the field capacity 0.038 fed/h, recorded at straw feed rate of 2 kg/min and the chassis tilt angle was adjusted at 28 degree.

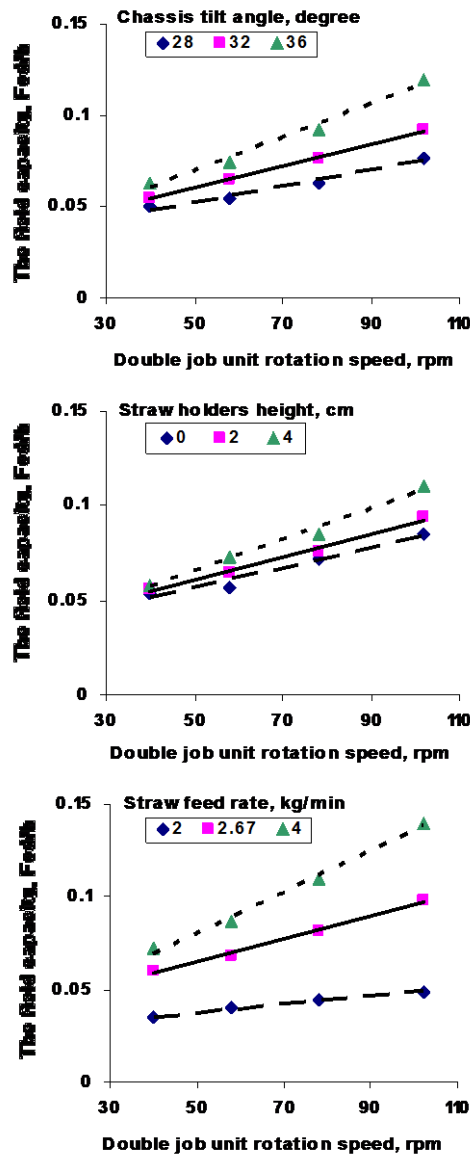

Fig. (6): The machine field capacity via operation speed.

Increasing the straw holder's heights from 0 to 2 cm increases the field capacity from 0.058 fed/h to 0.086 fed/h at decreasing the chassis tilt angles from 36 to 28 degree. Also increasing the straw holder's heights from 2 to 4 cm increases the field capacity from 0.06 to 0.096 fed/h at increasing tilt angle from 28 and 36 degree.

The statistically analysis of SAS showed that, there is high significance differences between different treatments with ($R^2 = 0.98$) and ($CV=8.8$).

A simple power regression analysis applied to relate the change in the field capacity for the proposed design with the change in the double job unit's rotation speed, chassis tilt angles, straw feed rates and straw holder heights for all treatments. The obtained regression equation was in the form of:

$$F_c = -0.16 + 0.00065 S + 0.0032 T + 0.028 Fr + 0.0035 H$$

The analysis of variance for the data of the field capacity for the proposed design at different double job unit rotation speed, chassis tilt angle, straw feed rate and straw holder height was in agreement with the previous gained results, the results indicated a highly significantly different for the previous treatments with ($R^2 = 0.79$).

The straw machine productivity (Mq, ton/fed.)

To verify the second aim of this paper, the machine productivity was conducted under different operation variables. Fig. (7) illustrates the relationship between the rotation speed of double job unit on the straw machine productivity.

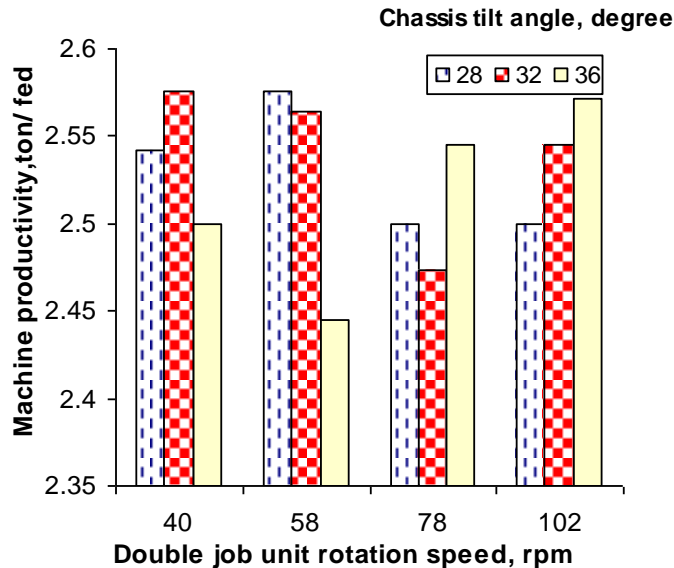

Fig. (7): the machine productivity via double job units speed

From Fig. 7, increasing the double job unit rotation speed, rpm decreasing the machine productivity from 2.5 to 2.44 ton/fed and then the relation increased at the tilt angle of 36 degree. The same trend was found at tilt angle of 32 degree.

CONCLUSION

The conclusions of this paper are summarized as follow:

- 1- The results indicated that the highest value of straw pick-up efficiency 98.21%, was obtained at 0 cm of straw holders height and the straw feed rate was adjusted at 2 kg/min. While the lowest value of the straw pick-up efficiency 95.77% recorded at 102 rpm of the combined unit rotation speed when the straw feed rate was adjusted at 4kg/min.
- 2- The results indicated that the highest value of straw pick-up losses 4.24%, was obtained at 102 rpm of the combined unit rotation speed and the straw feed rate was adjusted at 4 kg/min. While the lowest value of the straw pick-up losses 1.8% was recorded at 0 cm height for the straw holders when the straw feed rate was adjusted at 2 kg/min.
- 3- The results indicated that the highest value of the field capacity at the straw residue of 2.5 ton straw/fed was 0.17 fed/h which obtained at 102 rpm of the combined unit rotation speed and the straw feed rate was adjusted at 4 kg/min. While the lowest value of the field capacity 0.042 fed/h was recorded at 40 rpm of the rotation speed of the double job unit when the straw feed rate was adjusted at 2 kg/min.

REFERENCES

- ASAE Yearbook Standard (2007). Agricultural machinery management data. Standards, 45th Ed. St. Joseph, MI: ASAE, D497.1.
- The Statistical Year Book (2005). Central agency for public mobilisation and statistics.
- El-Ghonimey, M.I. and Rostom, M.N. (2002). performance evaluation of different pick-up press balers towards for handling of rice straw *Misr J. Ag. Eng.*, 19 (3) :705-720.
- Ismail, Z.E.; E.B. El-Banna; M.M. Ibrahim; and M.A. Shalaby (2007). Developing the drum of Turkish threshing machine *Misr J. Ag. Eng.*, 32 (9): 7325-7332.
- Kamei, M.; and N. Yamana (1998). Packing characteristics of small fixed chamber type roll baler. *Journal of the Japanese Society of Agricultural Machinery.* 60 (2): 111-116.
- Klenin, N.I.; Popov, I.F.; and V.A. Sakun, (1985). *Agricultural machines theory of operation* Co. Pvt. Ltd. New York PP. 633.
- Morad, M. M. , A. E. Hashish, A. F. Abd El-Mottaleb and A. M. El-Shal (2002). Effect of some operating parameters on pick-up baler performance. *Misr J. Ag. Eng.*, 19 (1): 136-158.
- Richey, C. b. (1958). discussion on energy requirements for cutting forage *agricultural engineering* 39(10):636-637.
- Srivastava, A. K.; C. E. Goering and P. R. Rohrbach (1995). *Engineering principles of agricultural machines.* ASAE Textbook, No (5), Published by American Society of Agricultural Eng.

إمكانية استخدام آلات اللقط والتقطيع للتخلص من فضلات الحقل
زكريا ابراهيم اسماعيل* ، عصام حسنى الحنفى و أحمد شوقي السيد السيد***
*** قسم الهندسة الزراعية- جامعة المنصورة**
**** معهد الكفاية الإنتاجية - جامعة الزقازيق - مصر. ***

لتحقيق الهدف من هذا البحث تم تنفيذ مراحل الدراسة على النحو التالي :

- ١ - دراسة بعض الخواص الطبيعية والميكانيكية لقس الأرز بعد عملية الدراس (طول القش، قطر القش، كتلة القش، المحتوى الرطوبى للقش).
 - ٢ - تصنيع وحدة جديدة تم تصميمها كبديل للتصميم الحالي لدرفيل الالتقاط حيث تعتمد فكرة التصميم الجديد على استخدام الجنازير اللاقطة وكذلك الجنازير الناقلة بواسطة الأصابع كبديل لاستخدام الشوك اللاقطة والأعمدة حيث تم الاستعانة ببعض الأجزاء الموجودة في كومباين الأرز الياباني لتنفيذ التصميم الجديد وذلك لتقليل تكاليف الصيانة للتصميم الحالي.
 - ٣- تقييم الأداء للتصميم الجديد وذلك باستخدام كميات مختلفة من قش الأرز وذلك لأنواع مختلفة من الأرز.
 - ٤- زيادة السعة الحقلية لوحدة المساحة لتقليل زمن التشغيل.
- والوحدة المطورة صُممت لكي تعمل على عمود الإدارة الخلفي للجرار ويتم تعليقها جانبياً على الجرار حيث تتكون من عدة أجزاء رئيسية وهي كالتالي:-

١- وحدة الرفع والالتقاط : وهي تنقسم إلي الأتي:-

١- السكينة الأمامية.

ب- الجنازير اللاقطة.

ج- ماسكات القش.

٢- وحدة الرفع : وهي تتكون من الجنازير الناقلة بواسطة الأصابع.

٣- جهاز نقل الحركة : وهو ينقسم إلي الأتي:-

١- الجهاز الفرقي.

ب- التروس الناقلة للحركة.

٤- وحدة التعليق الجانبي :- وهي تتكون من جهاز الشبك الثلاثي ووحدة نقل الحركة من الجرار.

تم اختبار وتقييم أداء الوحدة المطورة تحت متغيرات دراسية بمستويات مختلفة حيث تم إجراء تجربتين احدهما معملية و الأخرى حقلية تحت مختلف الظروف لتقييم أداء وحدة الرفع واللقط أولاً ثم تقييم الأداء لوحدة النقل ثم تقييم الأداء للتصميم بوجه علم.

وأظهرت النتائج أنه:

- 1 - كانت كفاءة الالتقاط ٩٨,٢١ % وذلك عند استخدام معدل تغذية للقش ٢ كجم/ الدقيقة وضبط ارتفاع الماسك عند صفر سم وكانت السرعة الدورانية للوحدة المزودة الوظائف ٤٠ لفة/ دقيقة وكانت زاوية ميل ال ٢٨ درجة.
- 2- كانت اعلي نسبة فقد في التقاط القش ٤,٢٤ % وذلك عند زيادة السرعة الدورانية للوحدة المزودة الوظائف إلي ١٠٢ لفة/ دقيقة وكانت زاوية ميل الاطار ٣٦ درجة وذلك عند استخدام معدل تغذية للقش ٤ كجم/ الدقيقة.
- 3- كانت اعلي كمية قش مرفوعة (معدل السريان) ٧,٠٧٥ كجم /دقيقة وذلك عندما كانت السرعة الدورانية للوحدة المزودة الوظائف إلي ١٠٢ لفة/ دقيقة وكانت زاوية ميل الاطار ٣٦ درجة وذلك عند استخدام معدل تغذية للقش ٤ كجم/ الدقيقة.
- 4- كانت اعلي سعة حقلية للتصميم هي ٠,١٧ فدان/ الساعة وذلك عندما كانت السرعة الدورانية للوحدة المزودة الوظائف إلي ١٠٢ لفة/ دقيقة وكانت زاوية ميل الاطار ٣٦ درجة وذلك عند استخدام معدل تغذية للقش ٤ كجم/ الدقيقة.