



The Egyptian International Journal of Engineering Sciences and Technology

Vol. 22 (January 2017) 35-42

<http://www.eijest.zu.edu.eg>



Comparative Study of Induction Motor De-Rating Factors

Mohamed A. Enany^a, Fathy E. Abdel-Kader^b, Nadia A. Elsonbaty^a, and Hani Abdo^{a*}

^a Electrical Power & Machines Department, Faculty of Engineering, Zagazig University, Egypt

^b Electrical Engineering Department, Faculty of Engineering, Menofeya University, Egypt

ARTICLE INFO

Article history:

Received: 29 August 2016

Received in revised form:

25 October 2016

Accepted: 19 November 2016

Available online:

26 November 2016

Keywords:

Induction motor performance

Unbalance voltages

Under / Over voltage

Harmonic Distortion

De-rating Factors

ABSTRACT

Induction motors are the commonly used motors in power industries, due to its low price, maintenance and easy to control, it consumes about 40% of the electrical energy all over the world. It is very common to find problems of power quality in electric supply systems, among of these problems unbalanced phase voltage and under / over voltage deviation. The developments in the power electronics field have led to an ever-increasing use of static switching devices to control the torque and speed of ac motors. Invariably, the output voltage and current waveforms of these devices are harmonically distorted in shape due to the existence of numerous harmonic orders; they primarily affect the performance operation of induction motors. Symmetrical component approach is adopted to estimate the performance of a three phase induction motor operating with unbalanced supply system or other factors. Further MATLAB/SIMULINK has been used simultaneously for simulation purpose. A new approach is proposed to de-rate the motor operating with these external factors in order to safe induction motors and increase its life time. This paper, therefore, presents a comprehensive study the influence of these external factors on induction motors behavior. A comparative study of induction motor de-rating factors is presented.

© 2017 EIEST. All rights reserved.

Nomenclature

NEMA	National Electrical Manufacturer Association.
IEC	International Electro-technical Commission.
CVUF	Complex Voltage Unbalance Factor.
VUF	Voltage Unbalance Factor.
V_p, V_n	Magnitude of Positive and negative sequence voltages.
θ_p, θ_n	Positive and negative sequence voltage angles.
θ_u	Voltage Unbalance Factor angle.

%V	Under/Over Voltage percentage.
V_{supply}	Supply Voltage.
$V_{nominal}$	Rated value of Supply Voltage.
$V_{max.dev}$	Max voltage deviation
V_{av}	Average line voltage
THD	Total Harmonic Distortion.
V_i	Harmonic order Voltage.
V_1	Fundamental Voltage.
R_1, R_2, R_c	Stator, Rotor and Core resistances.
X_1, X_2, X_m	Stator, Rotor and Magnetizing reactances.
I_{1p}, I_{2p}	Positive sequence stator and rotor currents.
I_{1n}, I_{2n}	Negative sequence stator and rotor currents.
I_a, I_b, I_c	Motor Phase currents.

* Corresponding author: Tel. +2- 01068923706

E-mail address: hani_eng5@yahoo.com

P_{in}	Motor input power
P_m	Motor mechanical output power
P_{loss}	Motor power losses.
s, ω_s	Operating slip and Synchronous speed in rad/s.
S_{po}, S_{nc}	Positive and negative-sequences Slip.
V_{ab}, V_{bc}, V_{ca}	Supply Line Voltages.
T_d	Motor Developed Torque.
AC, DC	Alternating and Direct Current.
IGBT	Insulated Gate Bipolar Transistor.
n	Harmonic order.
N_s	Synchronous speed in rpm.
N	Rotor speed.

1. Introduction

Induction motor is an important class of electric machines which is widely used in industrial, commercial and domestic applications. Due to its simple, rugged, inexpensive construction, reduced maintenance, and excellent operating characteristics, induction motors become very popular in industrial uses. As rough estimate nearly 80% of world industrial motors are poly-phase induction motors [1].

Voltage unbalance which is a common phenomenon is observed almost everywhere in a three phase system across the world. Although three phase voltage supply is quite balanced in both magnitude and displacement at the generation and transmission levels. It exits at utilization end due to unequal load distribution, incomplete transportation of transmission lines, defective transformers, blown fuses of three phase capacitor bank and so on.

The influence of unbalanced voltages on the performance of motor was first studied by Reed and Koppman in 1936 [2]. Further in 1956 Williams [3] proved that an induction motor operation with unbalanced voltage is undesirable. F. Woll [4] provided a simple and brief method in order to study the impact of unbalanced voltages on the losses and its negative effects on the insulating material of induction motor. In 2000 Wang [5] studied the influence of voltage unbalance upon the steady state performance of an induction motor analytically. It has been shown that voltage unbalance may cause the motor line currents to be very unbalanced. In 2001 Wang [6] evaluated the effects of voltage unbalance on induction motor by using (CVUF) that consist magnitude as well as angle to fully describe the voltage unbalance phenomenon. In 2002 Pillay and Hafmann [7] had examined the derating of an induction motor when supplied by unbalanced voltages in combinations with under/over voltages by

using electrical and thermal model. They concluded that the difference in definitions do not result in significant difference when operated by unbalanced supplies in the 5% range. In 2005 Faiz et al [8] proposed that inclusion of phase angle in addition to (VUF) give more accurate result. He introduced a method to determine the de-rating factor precisely using the (CVUF), in order to evaluate this factor, the machine is loaded such that the current do not exceeds the rated value, and de-rating factor is then computed as the ratio of the machine output power under unbalanced supply conditions to that under balanced condition. In 2006 Faiz et al [9] investigated that, for the same voltage unbalance, de-rated motor may have higher efficiency than non-rated motor.

In power system, the grid network is designed at nominal voltage value, and this voltage should maintain constant all the time, in real the voltage drop due to transmission lines led to under voltage at the load side, also transformer tap changer play an important role in the appearance of under/over voltage. The bad distribution of single phase loads, will led to some problems among of them the under/over voltage, so it is better to study the effect of supply under/over voltage on three phase induction motor. The under/over voltage factor is measured by %V the percentage increase or decrease in the supply voltage around the nominal voltage value.

The developments in the power electronics field have led to an ever-increasing use of static switching devices to control the torque and speed of induction motors [10]. Invariably, the output voltage and current waveforms of these devices contain numerous harmonics and these harmonics have detrimental effects on the induction motor performance. Harmonic Distortion factor is the degree to which a waveform deviates from its pure sinusoidal values as a result of the summation of all harmonic order occurs [11].

In this paper the performance of induction motor is investigated in the presence of de-rating factors, to obtain a comparative study of de-rating factors and its effect on the motor performance.

2. De-rating Factors Definitions

De-rating is the intentional reduction of applied stress on a component in order to assure reliability. The motor rated values are absolute maximum ratings, and are not to be exceeded under any conditions.

Absolute maximum ratings should never be exceeded regardless of changes in external conditions, since operation above absolute maximum rating values can shorten the life of motors. The motor must constantly

deliver that torque at any operating condition without exceeding the required temperature rise [12].

For induction motor there are many factors affecting its performance, these factors would make the induction motor to lose most of its properties such as speed ripple, torque variation up and down, and overheating. Some of these factors are:

- Unbalanced supply voltage.
- Over or under supply voltage.
- Harmonically distorted supply waveform.

2.1 Voltage Unbalance Factor

There are many definitions for voltage unbalance factor, which illustrated as below [13-14]:

The first definition is stated by (NEMA) Motor and Generator Standard and is given as the voltage unbalance factor percentage at the terminal of a machine, it can be determined as follow:

$$\% \text{ VUF} = (V_{\text{max.dev}} / V_{\text{av}}) * 100 \quad (1)$$

The second definition is stated by (IEC) and is given as the voltage unbalance factor, it can be determined as follow:

$$\% \text{ VUF} = (V_n / V_p) * 100 \quad (2)$$

Modification of VUF is the complex voltage unbalance factor (CVUF) that is defined as the ratio of negative-sequence voltage vector to positive sequence voltage vector. The CVUF is a complex quantity having the magnitude and angle [7, 14]. (CVUF) can be written as:

$$\% \text{ VUF} = (V_n \angle \theta_n / V_p \angle \theta_p) * 100 \quad (3)$$

2.2 Under / Over Voltage Factor

Under/over voltage means that the supply voltage is below or above the nominal voltage value, it can be calculated by[9]:

$$\% \text{ V} = (V_{\text{supply}} / V_{\text{nominal}}) * 100 \quad (4)$$

The negative sign of %V values means under voltage and positive sign values means over voltage.

2.3 Harmonic Distortion Factor

The total harmonic distortion of a signal is a measurement of the harmonic distortion present and is defined as the ratio of the sum of the powers of all harmonic components to the power of the fundamental. It provides an indication of the degree to which a voltage or current signal is distorted; it can be obtained from below equation [15]:

$$\% \text{ THD} = \frac{\sqrt{V_{2n}^2 + V_{3n}^2 + \dots + V_{nn}^2}}{V_1} * 100 \quad (5)$$

3. Induction Motor Model with Unbalanced Supply

The steady state model of three phase induction motor under unbalanced supply voltage or under/over supply voltage is obtained by means of symmetrical components analysis. The motor equivalent circuits are deduced under unbalanced conditions as shown in Fig.1 [16-17].

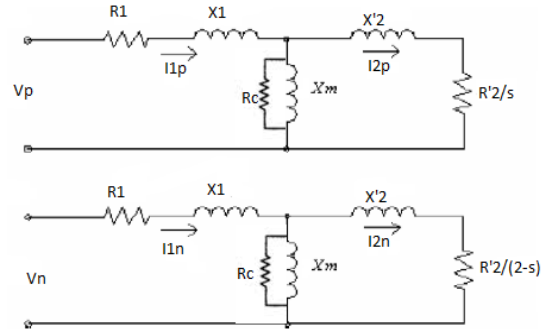

Fig. 1. Positive and negative-sequence equivalent circuits of induction motor

Assuming the motor is delta or ungrounded star connected. According to Fortescue’s method of symmetrical components, the positive and negative sequence line voltage components can be obtained from equation (6) as below [18-19]:

$$\begin{bmatrix} V_F \\ V_n \end{bmatrix} = \frac{1}{3} \begin{bmatrix} 1 & \alpha & \alpha^2 \\ 1 & \alpha^2 & \alpha \end{bmatrix} \begin{bmatrix} V_{ab} \\ V_{bc} \\ V_{ca} \end{bmatrix} \quad (6)$$

Where $\alpha = e^{j2\pi/3}$.

The motor performance characteristics are obtained by using the analysis of positive and negative sequence components. Stator current components can be easily deduced from Fig. 1. So the motor torque can be calculated as:

$$T_d = \left(\frac{3R_2}{W_s} \right) \left(\frac{I_{1p}^2}{s_{pp}} - \frac{I_{1n}^2}{s_{nn}} \right) \quad (7)$$

Also the motor power loss is deduced as shown equation (8) or (9).

$$P_{loss} = P_{in} - P_m \quad (8)$$

or
$$P_{loss} = \text{real} [3V_p I_{1p} + 3V_n I_{1n}] - 3R_2 (1 - s) \left(\frac{I_{1p}^2}{s_{pp}} - \frac{I_{1n}^2}{s_{nn}} \right)$$

So the motor currents can be calculated as:

$$\begin{bmatrix} I_a \\ I_b \\ I_c \end{bmatrix} = \begin{bmatrix} 1 & 1 \\ \alpha^2 & \alpha \\ \alpha & \alpha^2 \end{bmatrix} \begin{bmatrix} I_{1F} \\ I_{2n} \end{bmatrix} \quad (10)$$

The induction motor instantaneous characteristics curves when applying unbalanced power supply are obtained from the Simulink model of induction motor as shown in Fig. 2 and Fig. 3.

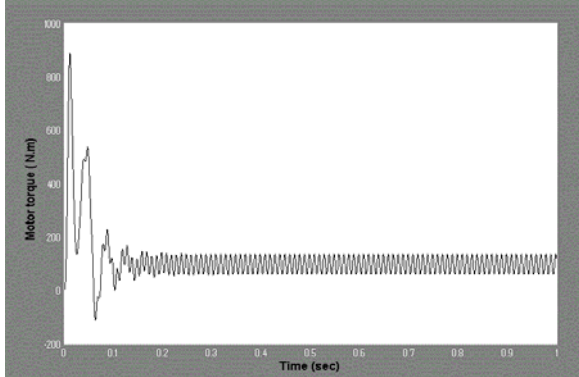

Fig. 2. Motor torque instantaneous characteristics

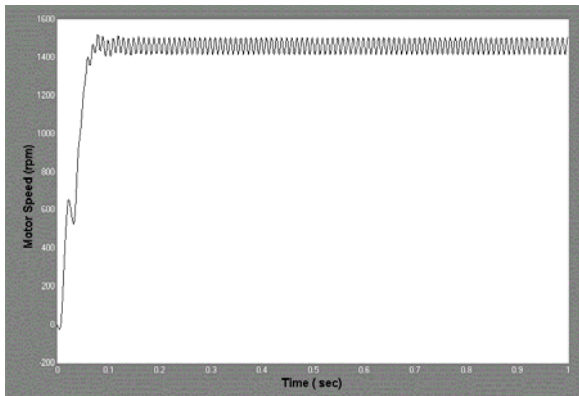

Fig. 3. Motor speed instantaneous characteristics.

From Fig. 2, and Fig. 3, it is clear that both motor torque and speed are oscillatory due to unbalanced supply.

The induction motor performance characteristics curves with unbalanced power supply are shown in Fig. 4 and Fig. 5.

From Fig. 4, it is clear that the motor net torque is lowered, due to the presence of negative sequence torque.

From Fig. 5, it is clear that the motor power losses increased, due to the presence of negative sequence torque.

For unbalanced supply the negative sequence component is increased with the increase of voltage unbalance factor value, Fig. 6 shows the effect of increasing negative sequence component on the supply power factor.

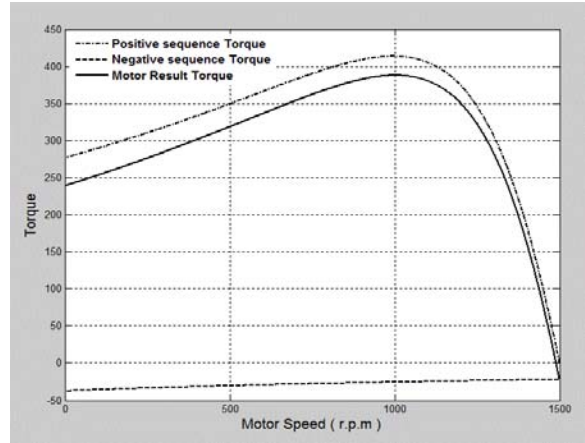

Fig. 4. Symmetrical components Torque-Speed characteristics due to unbalanced supply

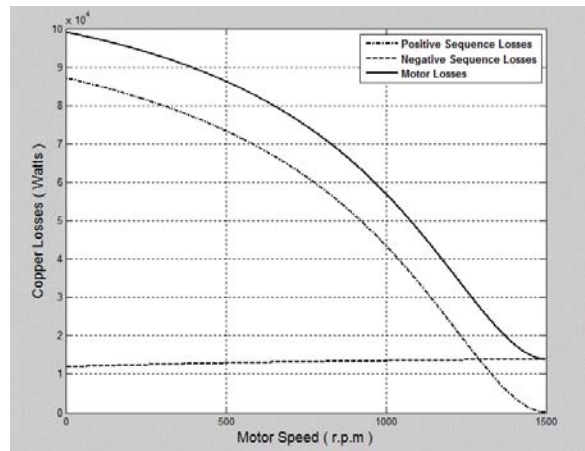

Fig. 5. Motor power losses due to unbalanced supply.

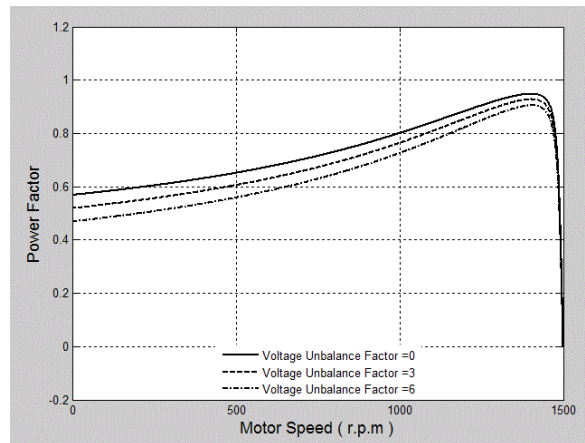

Fig. 6. Effect of Voltage Unbalance Factor on Supply Power Factor.

From Fig. 6, it is clear that the supply power factor is decreased, and its value decreased when the value of negative sequence component is increased.

Fig. 7 shows the effect of increasing negative sequence component on the supply required reactive power.

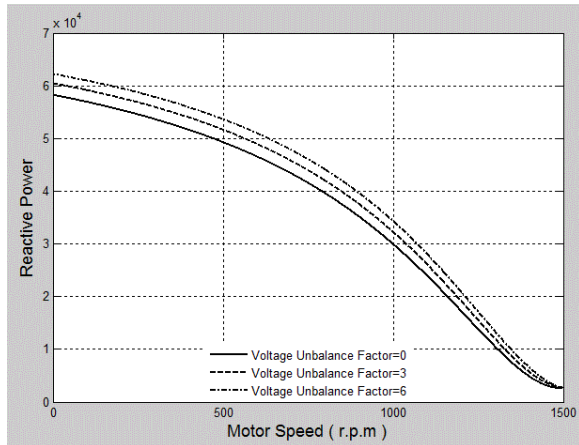

Fig. 7. Effect of Voltage Unbalance Factor on Supply Reactive Power

From Fig. 7, it is clear that the supply reactive power is increased, and its value increased when the value of negative sequence component is increased. Hence the unbalance supply affects badly on the supply power factor, and the required reactive power.

4. Induction Motor Model under Harmonically Distorted Waveform

The effect of harmonically distorted supply on induction motor performance can be evaluated by developing a series of independent equivalent circuits supplied by each individual harmonic voltage source [20]. Assuming linearity, superposition can be applied to add effects of individual harmonics and hence determine the machine performance under a harmonically distorted situation. Using this approach, total harmonic losses in the machine can be calculated by summation of separate losses corresponding to each harmonic frequency. Induction motor single phase equivalent circuit due to harmonic distorted supply circuit can be approximated by the circuit in Fig. 8 [21], where n is the harmonic order.

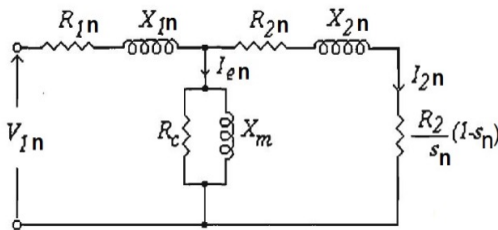

Fig. 8. Single phase equivalent circuit corresponding to the n^{th} harmonic order

The harmonic order slip corresponding to the harmonic order magnetic field is calculated as in equation (10):

$$s_n = \frac{\pm n N_s - N}{\pm n N_s} = \frac{\pm n - 1 + s}{\pm n} \quad (11)$$

The motor torque due to harmonic distorted supply voltage is shown in Fig.9.

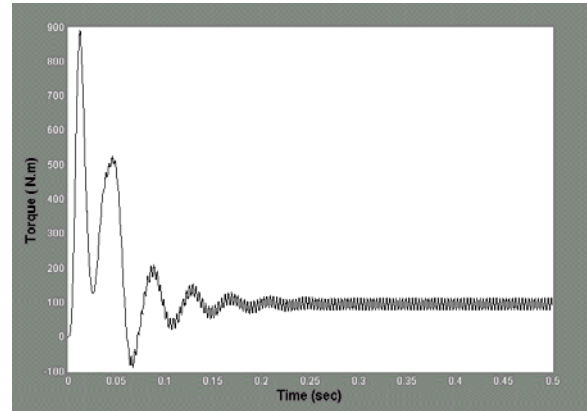

Fig. 9. Motor torque due to harmonic distorted supply

The harmonic content were measured by a totally harmonic distortion factor, it's obtained from equation (5).

Electrical Drive which is commonly used in modern industries is a two stage power conversion. First component of Electric drive is the rectifier, in which the AC sinusoidal supply is converted to DC electrical on a bus called DC Link. The second component is the converter, in which the DC supply converted to the desired AC voltage, and this converter is the control unit of the motor speed [22].

A three phase AC converter used to generate a harmonically distorted waveform, this waveform will be applied to a three phase induction motor model [23].

The Vector control method guide and control the firing angle value and phase of the used IGBT's, it has a speed reference and the feedback speed as inputs, according to these inputs it output the gate firing angle.

Change the firing angle of the converter Thyristor's or IGBT's will change the value of the output voltage then change the motor to the desired performance.

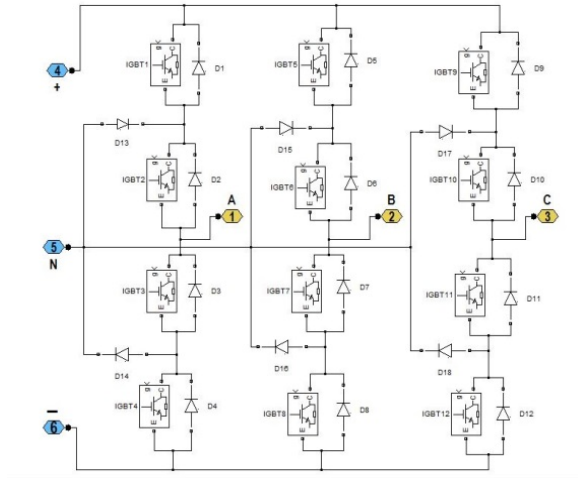

Fig. 10. Construction of AC converter

Fig. 10 shows the construction of the used AC converter, which mainly constructed by the IGBT technology in MATLAB SIMULINK.

5. Discussion and Simulation Results

The performance of induction motor is investigated in the presence of de-rating factors and recorded in form of characteristic curves as following.

5.1 Unbalanced supply Factor Results

When unbalanced supply is applied to induction motor, and controls the copper losses not exceeds the motor copper losses at the balanced condition. It is seems that motor torque should be decreased or derated by values as in Fig. 11.

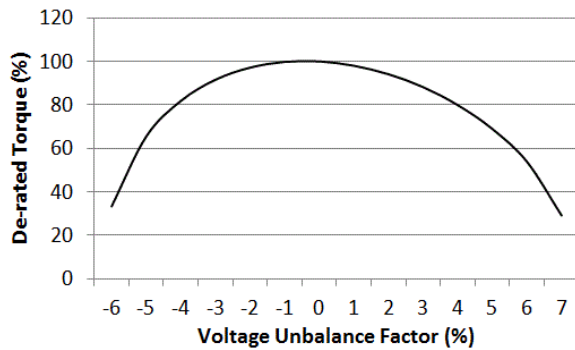

Fig. 11. De-rated torque for motor under unbalanced supply

It is seems that the largest motor torque occurred at balanced supply conditions (%VUF=0).

The motor line currents for the de-rated torque are changed, as shown in Fig. 12.

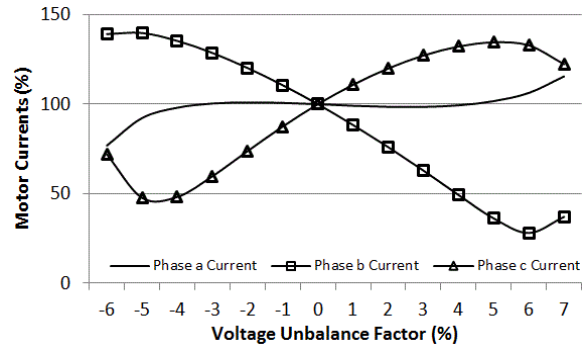

Fig. 12. Phases Current of De-rated motor under unbalanced supply

It is seems that the balanced and equal phase currents occurred when balanced supply condition (%VUF=0).

The motor efficiency decreased due to de-rating the motor torque, and can be represented as shown in fig. 13.

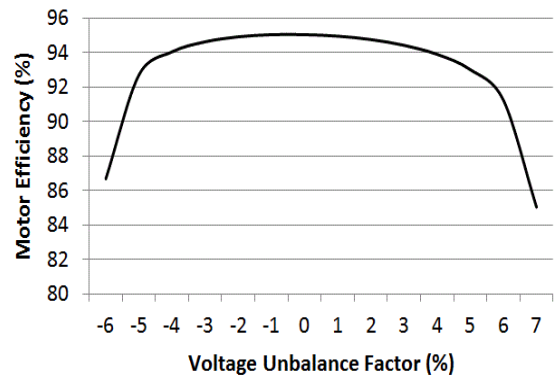

Fig. 13. Efficiency of De-rated motor under unbalanced supply

5.2 Under / Over Voltage Factor Results

When under/over voltage (balanced) supply is applied to induction motor, and control the copper losses not exceeds the motor copper losses at the balanced condition. It is seems that the motor load torque should be decreased or de-rated by values as in Fig. 14.

The largest torque occurred at rated motor voltage (%V=0).

The motor current for the de-rated torque is changed, as shown in Fig. 15.

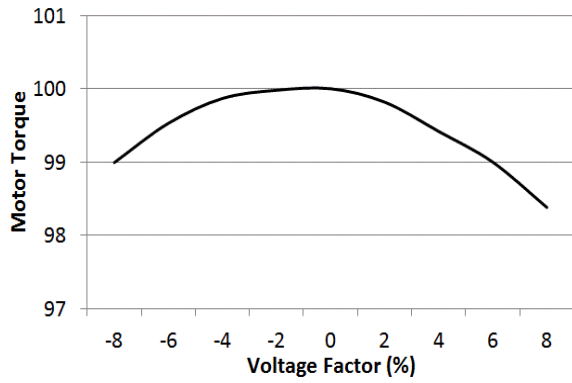

Fig. 14. De-rated torque for motor under Under/Over voltage supply

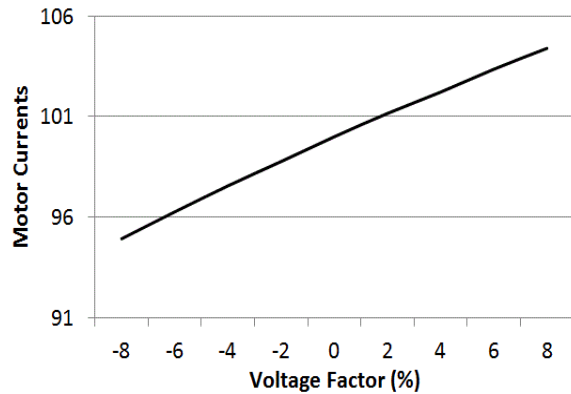

Fig. 15. Motor current under Under/Over voltage supply

The motor efficiency is decreased due to derating the motor torque, and can be represented as shown in Fig. 16.

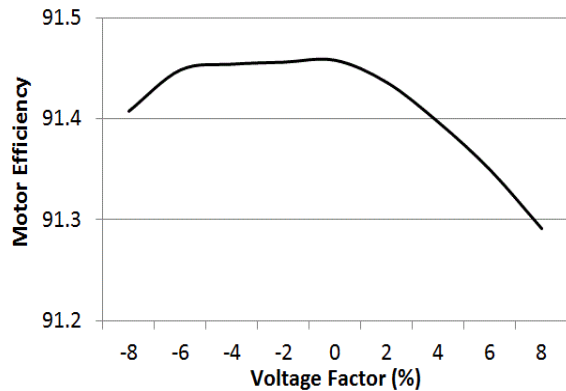

Fig. 16. Efficiency of motor under Under/Over voltage supply

5.3 Harmonically Distorted Waveform Factor Results

When harmonically distorted waveform supply is applied to induction motor, and control the copper losses not exceed the motor copper losses at the balanced sinusoidal waveform condition. The motor load torque should be decreased or de-rated by values as in Fig. 17.

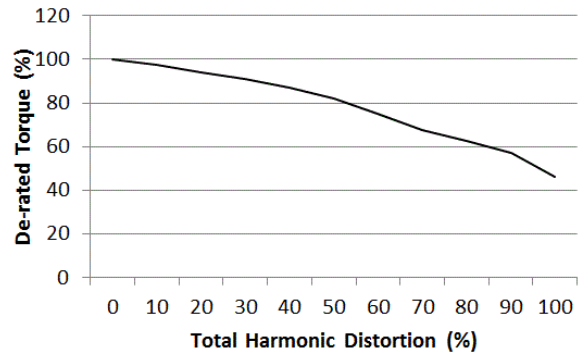

Fig. 17. De-rated torque for motor under Harmonically Distorted supply

At (%THD=0) the motor torque is maximum because of pure sinusoidal waveform supply voltage is applied to the motor.

For harmonically distorted waveform supply the motor torque is decreased.

6. Conclusions

The de-rated induction motor gets higher efficiency than non-derated one. De-rating factors effects on induction motor performance discussed in this work, the effect of voltage unbalance factor on induction motor performance is larger than the two other factors. For unbalanced supply factor the motor currents are unbalanced and have a large difference. The present study shows that if a motor operating under any of de-rating factor, it should be derated to save motor life and to improve the efficiency.

7. References

- [1] P. Waide and C. U. Brunner, " Energy-Efficiency Policy Opportunities for Electric Motors-Driven Systems". Working Paper of International Energy Agency, Energy Efficiency Series, OECD/IEA, 2011.
- [2] H. R. Reed and R. J. Koopman, "Induction motors on unbalanced voltages," AIEE Trans. Vol. 55, pp. 1206-1213, 1936.

- [3] J. E. Williams, "Operation of three phase induction motor on unbalance voltages", AIEE Trans, Vol-73, pp.125-133, April 1954.
- [4] R. F. Woll, "Effect of unbalanced voltage on the operation of poly-phase induction motor", IEEE Trans on IA, IA-11, No.1 pp. 38-42, Jan / Feb 1975.
- [5] Y.J. Wang, "Analytical study of study state performance three phase induction motor connected to unbalanced three phase voltage" IEEE Power Engineering Society, winter meeting, Singapore, pp. 23-27, January 2000.
- [6] Y.J. Wang, "Analysis of effects of three phase voltage unbalance on induction motors with emphasis on the angle of the complex voltage unbalance factor." IEEE Trans. On EC, vol.16, No.3, pp.270-275, 2001.
- [7] P. Pillay, P. Hoftman, and M. Manyage, "Derating of induction motors operating with the combination of unbalanced voltages and over or under voltages," IEEE Trans. EC, vol. 17, pp. 485-491, Dec. 2002.
- [8] J. Faiz and H. Ebrahimpour, "Precise derating of three phase induction motors with unbalanced voltages," IEEE Trans IAS, Vol.6, No.5, pp.485-491, 2005.
- [9] J. Faiz, H. Ebrahimpour and P. Pillay, "Influence of unbalanced voltage on efficiency of three phase squirrel cage induction motor and economic analysis" IEEE Trans EC, Vol.47, pp.289-302, 2006.
- [10] T. A. Buchh and A. Domijan, Jr., "Harmonic effect of electric vehicle loads," Int. Assoc. Science Technol. Development J. Power Energy Syst., vol. 21, no. 2, pp. 62-66, 2001.
- [11] V.J. Gosbell, S. Perera and V. Smith, " Harmonic Distortion in the electric supply system", Integral Energy Power Quality Centre, Technical No.3, March 2000.
- [12] Piotr G., "Windings Temperature and Loss of Life of an Induction Machine Under Voltage Unbalance Combined With Over or Under Voltages", IEEE Transactions on Energy Conversion, Vol. 23, No. 2, pp. 363-371, June 2008.
- [13] K. S. Sandhu, and V. Chaudhary, "Steady State Modelling of Induction Motor Operating With Unbalanced Supply System" WSEAS Transactions on CIRCUITS and SYSTEMS, issue 2, volume 8, pp 197-206, Feb. 2009.
- [14] R. Karthick, A. Arulvizhi, and N. Kamalakannan, " Performance Analysis of Three-Phase Induction Motor Operation with Unbalanced Supply System" International Journal of Research in Engineering, Science and Technologies (IJRESTs) - Circuit Branches, Vol. 1, No. 2, pp. 13-22, Sept. 2015.
- [15] Sudhir Sharma & K.S. Sandhu, "Role of Reactive Power Source on Power Quality of Three phase Self-Excited Induction Generator", WSEAS Transactions on Power Systems, issue 4, volume 3, pp 216-225, April 2008.
- [16] D.P. Kothari, and I.J. Nagrath, "Electric Machines, 3rd Edition, 2004, Tata McGraw Hill, New Delhi, India.
- [17] P.C. Krause, O. Wasynczuk, and S.D. Sudhoff, "Analysis of Electric Machinery, IEEE Press, 2002.
- [18] Sobhan Ghanbari, " Performance Evaluation of Three-Phase Induction Motor Fed by unbalanced voltage Using Complex Voltage Unbalance Factor", Journal of Engineering and Interdisciplinary Research, vol.1, No.2, pp.6-13, 2014.
- [19] Amaze A. Peter, Ignatius K. Okakwu, Akintude S. Alayande, Emmanuel S. Olowasogo, and Abel E. Airoboman, " Influence of Power Quality Problem on the Performance of an Induction Motor", The Pacific Journal of Science and Technology, vol.16, No.1, pp.5-11, May 2015.
- [20] S. Jalilzadeh, H. Hosseinian, S. Galvani, and F. Razavi, " Induction Motors Behavior Under Non Sinusoidal Voltage Supply Condition and Assessment of its Damages in Iran Network", Proceedings of the World Congress on Engineering and Computer Science 2007 WCECS 2007, October 24-26, 2007, San Francisco, USA
- [21] Cummings, P.G., "Estimating Effect of System Harmonics on Losses and Temperature Rise of Squirrel-Cage Motors" IEEE Transactions on Industry Applications, Vol. IA22, No. 6, pp. 1121-1126, Nov./Dec. 1986.
- [22] IEEE Power System Harmonic Working Group, " Bibliography of Power System Harmonics, Part I and II," IEEE PES Winter Power Meeting, Paper 84 WM 214-3, January/February 1984.
- [23] M. Y. Lee., "Three-level Neutral-point-clamped Matrix Converter Topology ". University of Nottingham. pp. 8. 2009